

SMART SKI HELMET: TECHNOLOGICAL APPROACH TO WINTER SPORTS SAFETY



POLITECNICO
MILANO 1863

Politecnico di Milano
Design School
MSc Design & Engineering

Supervisor:
Matteo Oreste Ingaramo

Student:
Ane Viteri Belza
10918840

Academic Year
2024-2025

Index

1. INTRODUCTION	7
1.1 Abstract	7
1.2 Methodological Framework	7
1.3 Reference words.....	9
2. BENCHMARKING. EMPATHY PHASE.....	11
2.1 User definition.....	11
2.2 Ski helmet brands.....	14
2.3 Ski helmets in the market.....	18
2.3.1 Atomic Ski	19
2.3.2 Salomon.....	20
2.3.3 POC.....	20
2.3.4 Head	21
2.3.5 Casco	22
2.3.6 Oakley.....	22
2.3.7 Livall.....	23
2.3.8 Bollé.....	23
2.4 Scientific and technical research	23
2.4.1 Safety rules for ski helmets	24
2.5 Internet of Things	27
2.5.2 Wireless sensors.....	29
2.5.3 Applied technology.....	29
2.6 Human ergonomics	31
2.6.1 Helmet sizing	32
2.6.2 Color analysis.....	33
2.6.3 Tactile analysis	35
2.7 Conclusions.....	35
2.7.1 Persona	36
3. PRODUCT POSITIONING. DEFINITION PHASE.....	37
3.1 SWOT analysis	37
3.2 Product Positioning Chart.....	38
3.3 Kpi's	40
3.4 Conclusions.....	40
4. IDEATION AND PROTOTYPING	43
4.1 Brainstorming	43
4.1.1 Moodboard.....	44

4.2 Main ideas development.....	45
4.3 Final Design definition.....	48
5. FINAL PRODUCT PROPOSAL	51
5.1 3D model	51
5.1.1 General explanation	51
5.1.2 Detailing	53
5.2 Material selection.....	56
5.3 SolidWorks Simulations	57
5.4 Technical information	60
5.5 Batch size.....	61
5.6 Bill Of Materials.....	62
5.7 Technical drawings	63
5.8 Manufacturing processes	67
5.9 Assembly process	69
5.10 Final product presentation.....	71
5.10.1 Appearance justification.....	75
6. PROJECT MONITORING AND FINANCES	77
6.1 Budget	77
6.1.1 Design budget.....	77
6.1.2 Material procurement and manufacturing budget	78
6.3 Project Gantt	79
7. CONCLUSION	81
8. REFERENCES	83
8.1 General information	83
8.2 Product links.....	85
9. ANNEXES.....	87
ANNEX 1. DOC. UNE-EN 1077.....	88
ANNEX 2. SOLIDWORKS SIMULATIONS STRUCTURAL ANALYSIS DOCUMENT.....	89
ANNEX 3. SOLIDWORKS SIMULATIONS DROP ANALYSIS DOCUMENT.....	90
ANNEX 4. PRODUCT RENDERING	¡Error! Marcador no definido.
ANNEX 5. BILL OF MATERIALS BUY COMPONENT DATASHEETS.....	91
ANNEX 6. TECHNICAL DRAWINGS	92
ANNEX 7. PROJECT GANTT	93

Figure Index

Figure 1: Design Thinking.....	8
Figure 2: Image of normal skier with helmet and goggles.....	11
Figure 3: First time skier	12
Figure 4: Middle level frequent skier	12
Figure 5: Freeride skier	13
Figure 6: Main picture for selected user type	13
Figure 7: Smith Vantage MIPS	14
Figure 8: POC OBEX BC Spin	14
Figure 9: Giro Range MIPS.....	15
Figure 10: Atomic Revent + Amid	15
Figure 11: Salomon MNT Lab	16
Figure 12: Sweet protection Grimnir II TE	16
Figure 13: Scott Symbol 2 Plus D	16
Figure 14: Bern Watts EPS	17
Figure 15: Bollé B-Style.....	17
Figure 16: K2 Diversion.....	17
Figure 17: Uvex Jakk + IAS	18
Figure 18: Four AMID Pro	19
Figure 19: Savor GT AMID Ctd	19
Figure 20: Pioneer LT Pro.....	20
Figure 21: POC Fornix Helmet	20
Figure 22: POC Obex MIPS Helmet.....	20
Figure 23: POC Obex BC MIPS	21
Figure 24: Compact Pro Ski Helmet.....	21
Figure 25: REV Ski Helmet	21
Figure 26: SP-4.1.....	22
Figure 27: Oakley MOD5 - MIPS.....	22
Figure 28: MOD1 Pro-SL	22
Figure 29: C20 Livall Urban Helmet.....	23
Figure 30: RYFT MIPS Bollé.....	23
Figure 31: Front-end brain damage by high force impact.....	25
Figure 32: Example of each type of helmet described above	26
Figure 33: IoT mind map	27
Figure 34: Wristwatch, example of IoT applications	28
Figure 35: LED light stripe.....	28
Figure 36: POC aid headphones	29
Figure 37: RECCO technology logo	30
Figure 38: Head fitting rolling system example	30
Figure 39: MIPS System scheme.....	30
Figure 40: Human head measurements and reference for helmet charts.....	32
Figure 41: Stripe around head to measure size.....	33
Figure 42: Multicolor POC helmet.....	33
Figure 43: POC-ito bright ski helmet colors.....	34
Figure 44: Persona image	36
Figure 45: Product positioning chart.....	39
Figure 46: Moodboard.....	44

Figure 47: Idea 1 first drawing.....	45
Figure 48: Idea 2 first drawing.....	46
Figure 49: Main sketch of future development idea.....	49
Figure 50: Main idea sketches.....	50
Figure 51: 3D model isometric view.....	51
Figure 52: Exploded view for design parts.....	52
Figure 53: Detailed exploded view of LED case.....	52
Figure 54: Helmet assembly front, lateral and top views.....	53
Figure 55: LED light box lateral view for snap-fits.....	54
Figure 56: ABS / PC shell box slits to insert snap-fits.....	54
Figure 57: Zoom in to LED case snap-fits.....	55
Figure 58: On/ Off button tactile relief vision.....	55
Figure 59: Structural Analysis final graph.....	57
Figure 60: Strain analysis.....	58
Figure 61: Strain simulation graph for Drop Tests.....	59
Figure 62: Material properties table for helmet shell.....	59
Figure 63: BOM.....	62
Figure 64: Total Assembly Technical Drawing_Main dimensions.....	64
Figure 65: Total Assembly Technical Drawing_Main exploded view.....	65
Figure 66: Total Assembly Technical Drawing_BOM.....	66
Figure 67: Product isometric exploded view render.....	71
Figure 68: Exploded views render.....	72
Figure 69: Back view of product.....	73
Figure 70: Helmet render.....	74
Figure 71: Helmet render.....	74
Figure 72: Design budget.....	77
Figure 73: Manufacturing budget.....	78
Figure 74: Project Gantt Phases.....	79

Table Index

Table 1: SWOT analysis of product design.....	38
Table 2: Positive aspects of both design paths.....	48
Table 3: Negative aspects of both design paths.....	48

ANNEXES Index

ANNEX 1. DOC. UNE-EN 1077	88
ANNEX 2. SOLIDWORKS SIMULATIONS STATIC ANALYSIS	89
ANNEX 3. SOLIDWORKS SIMULATIONS DROP ANALYSIS	90
ANNEX 4. BILL OF MATERIALS BUY COMPONENT DATASHEETS	91
ANNEX 5. TECHNICAL DRAWINGS	92
ANNEX 6. PROJECT GANTT	93

1. INTRODUCTION

1.1 Abstract

This thesis focuses on the design proposal for a ski helmet that incorporates advanced technological applications to promote user safety while practicing this sport. The research began with a thorough market study, willing to identify and analyze the products currently available. This analysis helped understand the features and functionalities that consumers value in existing ski helmets. With this information, the goal was to innovate and subsequently add value to an already known and accepted product.

The proposed helmet maintains a traditional exterior appearance, making it easy to identify as a ski helmet. However, its true value lies in the interior redesign, which breaks conventional standards and offers significant improvements in terms of safety and comfort. This redesign includes the integration of sensors, providing alerts and recommendations to prevent accidents. Additionally, the helmet features a communication system that allows the user to stay in touch with other skiers and emergency services if needed.

The research also explored current trends in wearable technology and how these can be applied to ski helmet design. Aspects such as material durability, efficiency of electronic components, and user-friendliness were considered. The result is a helmet that not only meets current safety standards but also anticipates the future needs of skiers in an increasingly connected and technological world.

In summary, this ski helmet represents a fusion of tradition and innovation. Its exterior design retains the classic aesthetic that users expect, while its interior incorporates cutting-edge technologies that enhance the skiing experience. This product is expected to be not only useful and efficient but also to set a trend in the new culture of modern technology applied to sports. With this helmet, skiers can enjoy their favorite sport with greater peace of mind and safety, knowing they are protected by equipment designed with the future in mind.

1.2 Methodological Framework

The design context for this project is the development of a safety element for alpine skiing, specifically a ski helmet. Alpine skiing is a popular winter sport that involves descending snow-covered slopes on skis with fixed-heel bindings. Given the inherent risks associated with high speeds and variable floor, safety equipment is crucial. This project focuses on creating a ski helmet that not only meets but exceeds current safety standards by incorporating advanced technological features.

The design of this ski helmet is centered on the common user, defined as a frequent and experienced alpine skier. These individuals are familiarized in the sport, understand the importance of safety, and consistently wear helmets while skiing. They value innovations that enhance their safety and performance on the slopes. Therefore, the design process must consider their specific needs and preferences.

The geographical focus of this project is Europe, particularly the Alps, the Spanish and French Pyrenees, and the northern part of the continent. These regions are known for their ski resorts and have seen a significant increase in the popularity of alpine skiing over the past few decades. Since the mid-20th century, skiing has emerged from a niche activity to a mainstream sport, attracting millions of enthusiasts each year¹.

This growth has been driven by high developments in ski technology, improved accessibility to ski resorts, and the increasing appeal of winter sports tourism.

The primary objective of this project is to innovate the traditional ski helmet by integrating Internet of Things (IoT) applications. This involves incorporating wireless connectivity and internet features to enhance on-piste safety. The to-be-designed helmet will provide real-time data and connectivity, offering features such as GPS tracking, collision detection, and emergency alerts. These functionalities aim to improve the overall safety and experience for skiers by enabling immediate response in case of accidents and providing valuable information to both the skier and rescue teams.

To achieve this, the Design Thinking methodology will be applied. This user-centered approach ensures that the design process is iterative and responsive to user feedback. The methodology consists of five phases: Empathize, Define, Ideate, Prototype, and Test. Each phase plays a critical role in developing a product that truly meets the needs of the target users².



Figure 1: Design Thinking

This methodological framework sets the stage for the project, ensuring a user-centered approach to designing an innovative ski helmet that enhances safety through advanced technology. By following the Design Thinking process, the project aims to create a product that meets the needs of experienced alpine skiers and contributes to safer skiing experiences in Europe. The integration of IoT applications into the ski helmet represents a significant advancement in ski safety equipment, offering new levels of protection and peace of mind for skiers.

1.3 Reference words

Ski, helmet, safety, LED light, technology, IoT, user, inctuitive.

2. BENCHMARKING. EMPATHY PHASE

2.1 User definition

Currently, it is common to observe that many amateur skiers purchase high-cost ski equipment without a clear understanding of its value, purpose, or proper use. This trend not only creates confusion regarding the level of professionalism required for each type of equipment but also can lead to underutilization of the materials, affecting both the user's experience and their safety on the slopes. The lack of adequate information and the influence of marketing can lead these skiers to invest in equipment that does not match their actual needs or skill level, creating a discrepancy between the equipment used and the skier's abilities.

To address this issue, the benchmarking section of this thesis will conduct a thought analysis of various ski brands that offer high-quality materials at reasonable prices. The aim of this analysis is to provide a clear and objective reference for skiers, helping them make informed decisions when purchasing their equipment. Aspects such as durability, performance, and value for money will be evaluated to identify options that are not only economically accessible but also meet the necessary quality standards for safe and enjoyable skiing.

This approach will enable traditional skiers to better understand the characteristics and benefits of the different equipment available on the market, facilitating a more conscious choice aligned with their skill level and goals in the sport. Additionally, it will help demystify the notion that “more expensive equipment is always the best option”, promoting a culture of more informed and responsible consumption within the skiing community.



Figure 2: Image of normal skier with helmet and goggles

This section provides a detailed analysis of the target users for the smart ski helmet design. For the product selection, profiles of skiers have been created, covering most snow sports enthusiasts, from beginners to amateurs. These profiles aim to meet their different needs with this helmet, focusing on aspects like safety, performance, and comfort. Below is a list of the specific requirements for each user profile, ensuring that the helmet design fulfills their needs and enhances their personal experience on the slopes.

The type of persona has been divided into:

Beginner Skier (first time skier / few days into skiing)

- Real-Time guidance and assistance: navigation instructions, slope alerts, and changes in floor difficulty.
- Fall Detection: automatic notifications to emergency contacts in case of bad falls.
- Impact Protection: advanced impact absorption technology.
- Health monitoring: tracking heart rate and other vital signs.
- Ease of Use: User-friendly and easy-to-understand interface.
- Affordable Cost: good balance between functionality and price.



Figure 3: First time skier

Intermediate skier (traditional skier at slopes)

- Performance Analysis: statistics on speed, distance traveled, jump height, and descent efficiency.
- Additional Safety: warnings for dangerous areas and bad weather conditions.
- Communication: connectivity with mobile devices for calls and messages.
- Personalization: options to customize the helmet's interface and functions.
- Advanced Performance Data: precise movement measurement, technique analysis, and improvement recommendations.
- GPS System: detailed maps of trails and off-piste routes.
- Real-Time Conditions: Updated information on snow, weather, and slope traffic.
- Durability: Lightweight and resilient materials that withstand extreme conditions.
- Family Tracking: Real-time location of family members.
- Safety Alerts: Notifications about dangerous conditions and safe meeting points.
- Easy Communication: Easy communication between family members on the slopes.
- Full Protection: Complete head and face coverage with padded and comfortable materials.



Figure 4: Middle level frequent skier

Freerider, mountain skier, ski competitor

- Built-in Camera: High-definition video recording and photography.
- Impact Sensor: Advanced detection of impacts and vibrations.
- Integrated Audio: Music playback and communication with other skiers.
- Jump and Trick Tracking: Recording height, rotations, and landings of jumps.

- Live Telemetry: Real-time data on speed, ski angles, and G-forces.
- Aerodynamic Optimization: Design that minimizes wind resistance.
- Instant Feedback: Immediate performance feedback during races.
- Connectivity with Coaches: Real-time data sharing with coaches and support teams.
- GPS and Navigation: Advanced tools for navigating remote areas.
- Emergency Communication: Ability to send distress signals and exact location.
- Weather Monitoring: Accurate information on weather conditions and avalanche risks.
- Topographic Maps: Detailed maps of mountainous geography and ski routes.



Figure 5: Freeride skier

After this exhaustive analysis of the type of personas that might perform in the ski industry as the final user of the helmet to-be-designed, the list of characteristics that our final persona is looking forward to finding in the helmet, is very reduced to the following characteristics:

ALPINE SKIER: MIDDLE LEVEL / FAMILY SKIER



Figure 6: Main picture for selected user type

- Communication: connectivity with mobile devices for calls and messages.
- Integrated Audio: music playback and communication with other skiers. Phone calls.
- Enhanced Visibility: Integrated LED lighting and reflectors.
- Emergency Communication: ability to send distress signals and exact location.
- Impact Protection: advanced impact absorption technology. MIPS
- Total Protection: complete head and face coverage with padded and comfortable materials.
- Durability: strong and lightweight materials that work well in extreme conditions.
- Affordable Cost: good balance between functionality and price.
- Comfort and Style: attractive and comfortable design for prolonged use.

2.2 Ski helmet brands

Choosing the right ski helmet is crucial for safety and performance. This analysis reviews ten leading brands, categorizing them by market impact, reputation, and affordability. By exploring the features and strengths of helmets from Smith Optics, POC, Giro, Atomic, Salomon, Sweet Protection, Scott, Bern, Bollé, K2, and Uvex, this guide helps skiers find the perfect helmet to match their needs and enhance their skiing experience.

High-Impact Brands with Technological, Safe, or Innovative Helmets

<p>Smith Optics - Smith Vantage MIPS ^A</p> <p>“The Smith Vantage MIPS helmet is renowned for its advanced safety features, including the MIPS (Multi-directional Impact Protection System) technology, which reduces rotational forces during impacts. It also features Aerocore construction with Koroyd, providing superior protection and ventilation.”</p>	
<p>275 €</p>	<p>Figure 7: Smith Vantage MIPS</p>
<p>POC - POC Obex BC Spin ^B</p> <p>“The POC Obex BC Spin helmet is designed for backcountry skiers, featuring the SPIN (Shearing Pad Inside) technology that minimizes the effects of oblique impacts. It also includes an NFC Medical ID chip for emergency situations and RECCO reflectors for searchability. “</p>	
<p>202.46 €</p>	<p>Figure 8: POC OBEX BC Spin</p>

<p>Giro - Giro Range MIPS ^C</p>	
<p>“The Giro Range MIPS helmet offers a custom fit with its Conform Fit Technology, which uses a two-piece shell to adapt to the shape of the skier's head. It also incorporates MIPS technology and boasts excellent ventilation with its Thermostat Control adjustable venting. “</p>	
<p>269.95 €</p>	

Figure 9: Giro Range MIPS

Brands with a Strong Reputation in Alpine Skiing



<p>Atomic - Atomic Revent+ Amid ^D</p>	
<p>“The Atomic Revent+ Amid helmet is known for its high level of protection, featuring AMID (Atomic Multi-directional Impact Deflector) technology that absorbs shocks from all angles. It also has a Holo Core construction for enhanced impact protection and ventilation.”</p>	
<p>160 €</p>	

Figure 10: Atomic Revent + Amid

<p>Salomon - Salomon MTN Lab ^E</p>	 <p>Figure 11: Salomon MNT Lab</p>
<p>“The Salomon MTN Lab helmet is lightweight and designed for both skiing and mountaineering. It meets safety standards for both sports and includes EPS 4D technology for superior shock absorption.”</p>	
<p>249.95 €</p>	

<p>Sweet Protection - Sweet Protection Grimnir II TE ^F</p>	 <p>Figure 12: Sweet protection Grimnir II TE</p>
<p>“The Sweet Protection Grimnir II TE helmet is a top choice for freeride skiers, featuring carbon fiber reinforcement for maximum protection and MIPS technology. It also has a moisture-wicking liner and adjustable ventilation.”</p>	
<p>299.95 €</p>	

<p>Scott - Scott Symbol 2 Plus D ^G</p>	 <p>Figure 13: Scott Symbol 2 Plus D</p>
<p>“The Scott Symbol 2 Plus D helmet offers excellent protection with its D3O technology, which hardens upon impact to absorb shock. It also includes MIPS and has a dual active venting system for comfort.”</p>	
<p>146.99 €</p>	

Affordable and High-Selling Brands

<p>Bern - Bern Watts EPS ^H</p>	 <p>Figure 14: Bern Watts EPS</p>
<p>“The Bern Watts EPS helmet is a popular choice for its affordability and solid protection. It features a thin ABS shell lined with EPS foam for impact absorption and has a simple, stylish design.”</p>	
<p>59.99 €</p>	

<p>Bollé - Bollé B-Style ^I</p>	 <p>Figure 15: Bollé B-Style</p>
<p>“The Bollé B-Style helmet is known for its lightweight and comfortable fit. It includes adjustable ventilation and a Click-to-Fit system for easy size adjustments.”</p>	
<p>68.95 €</p>	

<p>K2 - K2 Diversion ^J</p>	 <p>Figure 16: K2 Diversion</p>
<p>“The K2 Diversion helmet offers great value with its hybrid construction, combining a hard shell with in-mold elements for durability and lightness. It also features a 360 K2 dialed fit system for a secure fit.”</p>	
<p>169.95 €</p>	

<p>Uvex - Uvex Jakk+ IAS^K</p>	
<p>“The Uvex Jakk+ IAS helmet is appreciated for its lightweight and robust construction. It includes an IAS fit system for precise adjustments and excellent ventilation for comfort.”</p>	
<p>149.95 €</p>	

Figure 17: Uvex Jakk + IAS

Selecting the right ski helmet is crucial for ensuring safety and comfort on the slopes. It's important to consider the type of skiing you engage in, whether it's backcountry, alpine, or freestyle, as different helmets offer features tailored to these activities. High-impact brands like Smith, POC, and Giro provide advanced technologies that enhance safety and performance, making them ideal for serious skiers who prioritize protection and innovation.

Brands with a strong reputation, such as Atomic, Salomon, Sweet Protection, and Scott, are known for their quality and reliability, often featuring in professional skiing circuits. These helmets are designed to withstand high impact use and provide excellent protection, making them a great choice for great motivated skiers.

For those looking for more affordable options, brands like Bern, Bollé, K2, and Uvex offer reliable helmets that provide essential safety features without breaking the bank. These helmets are perfect for recreational skiers who need dependable protection at a lower cost.

In conclusion, understanding your skiing style and needs will help you choose a helmet that offers the right balance of safety, comfort, and performance. Investing in a good helmet is an investment in your safety, ensuring you can enjoy the slopes with confidence.

2.3 Ski helmets in the market

In the "Market and Competitor Analysis" section, I will explore the dynamic landscape in which my project of developing and designing a smart ski helmet with LED lights, security system, and protection will be placed. This analysis will provide a detailed view of market trends in the winter sports industry, assessing existing demand and emerging opportunities. Additionally, I will examine competitors' products in-depth, highlighting some characteristics of each of them, to better understand the competitive context in which my helmet will be operating. This approach will allow me to identify key areas of differentiation and strategic opportunities to effectively position my product in the market.

In order to make this process easier, I have created a list of worldwide known brands that already offer ski material and can be potentially interested in the development of a similar product to this one: atomic, Salomon, POC, head, casco out from others, are on top of the list. (The list shown in the previous section was just about affordable/ non-affordable helmets that do not have to be in fact recognized. I didn't know about some of those brands before the research).

2.3.1 Atomic Ski

Four Amid Pro^L	
Weight: 380g	
AMID (Atomic Multi-directional Impact Deflector)	
3D molded cushions	
Aircon venting for helmet ventilation	
Merino 3M X-Static lining: made of merino wool with antimicrobial and anti-odor properties	
RECCO technology: to locate skiers who have encountered problems	

Figure 18: Four AMID Pro

Savor GT AMID Ctd^M	
Smart helmet shock sense technology	
SOS alert function	
Weight: 700g	

Figure 19: Savor GT AMID Ctd

2.3.2 Salomon

Pioneer LT Pro^N	
Adaptive ventilation system with an adjustable tab for needs	
Weight: 400g	
Safety: EPS - 4D	
Shell: lightweight PC	
Lining: advanced active dry	
Standards : CE-EN1077//ASTM-F-2040	

Figure 20: Pioneer LT Pro

2.3.3 POC

POC Fornix Helmet^o	
Shell: ABS	
Bridges: Aramid	
Core: EPS	

Figure 21: POC Fornix Helmet

POC Obex MIPS Helmet^P	
Protection against rotational impacts MIPS: "Multi Directional Impact Protection System"	
Dual-material shell	
Compatible with POC Aid headphones	
Lining: EPS	
Shell: PC	
Top cover: ABS	
Goggle clip	
Removable pads	
Total weight: 1kg	

Figure 22: POC Obex MIPS Helmet

POC OBEX BC MIPS ^R	
MIPS evolve security system	
TwICEme MFC medical ID: Medical info stored on the twICEme [®] NFC Medical ID chip can easily be read by co-riders and first responders with a tap of a smartphone.	
RECCO reflector for avalanche rescue system	

Figure 23: POC Obex BC MIPS

It is interesting to add a short article about the POC OBEX Ski Helmets after this analysis, in where an expert review is explained. Here we can find some expert opinion about POC. ³

2.3.4 Head

Compact Pro Ski helmet ^R	
360° microshell: PC shell to avoid scratches.	
Sphere fit: patented free hanging fit system that wraps around your head like a beanie	
BOA fit system allows you to adapt the helmet perfectly to you head creating a comfortable fit without any pressure	
EN 1077:2007 Class B standards	

Figure 24: Compact Pro Ski Helmet



REV ski helmet ^S	
In-Mold Technology The inner EPS layer absorbs impacts and is injected through the outer hard polycarbonate shell to create a single piece that offers perfect protection at a reduced weight.	
360° Microshell is a polycarbonate layer that wraps three-dimensionally around the lower edge of the helmet, preventing scratches and dents in the helmet's foam.	
Neckgator The neck gaiter provides comfort and warmth thanks to its excellent fit, protecting you from the elements.	
EN 1077:2007 Class B	

Figure 25: REV Ski Helmet

2.3.5 Casco

SP-4.1 ^T	
DiskFit Vario - helmet measurement	 <p>Figure 26: SP-4.1</p>
FX magnet link	
Goggles magnetic attachment	
System adjustment with a small wheel in the back neck	

2.3.6 Oakley

OAKLEY MOD5 – MIPS ^U	
MIPS	 <p>Figure 27: Oakley MOD5 - MIPS</p>
Polartec® Power Grid™: With a three-dimensional, absorbent, removable, and washable liner that conforms to the user's head	
BOA® 360 FIT SYSTEM: Fully adjustable design to provide an exact fit	
FIDLOCK® BUCKLE: Magnetic, seamless functionality allows you to fasten the helmet with gloves on	
Certifications: ASTM F2040 and CE EN1077	

MOD1 PRO SL ^V	
DURA-MATTER: an outer layer injected with molded Dura-Matter applied over a layer of expanded polystyrene foam	 <p>Figure 28: MOD1 Pro-SL</p>
SKULL MATRIX: MIPS® and BOA® technologies combined	
FIXED VENTILATION: slots at the front of the helmet provide ventilation for the goggles, and the top slots help keep the skier cool	
FIDLOCK® BUCKLE: magnetic device allows you to fasten the helmet with gloves on.	

2.3.7 Livall

C20 - Urban Helmet ^w	
SOS system	
Compatible with Strava, iHealth and Siri	

Figure 29: C20 Livall Urban Helmet

2.3.8 Bollé

RYFT MIPS Bollé Helmet ^x	
Fitlock integrated magnet closing system	
Active panel ventilation	
MIPS	

Figure 30: RYFT MIPS Bollé

2.4 Scientific and technical research

In this section, I will emerge myself into the fundamentals supporting the development and design of the innovative smart ski helmet. In this detailed analysis, I will address technical and scientific aspects essential for understanding structural integrity, LED light efficiency, and the effectiveness of the security and protection system. I will examine the correlation in between these disciplines to ensure that my helmet not only meets safety standards but also provides a technically and scientifically advanced experience for skiing users that will enjoy this new helmet design. This rigorous analysis will allow me to ground every aspect of my design in solid knowledge and ensure a cutting-edge product in the scientific and technical areas.

In order to do that, I have followed a prearranged order about the research, depending on how they will affect the following aspect to reach: first of all safety, in which materials conditions, parts that comprehend the helmet and safety measurements / rules are included; after that the technology involved, in which LED light technology, wireless connections, sensors and other AI supplements are included (as repeatedly mentioned through the document until now); to finish, I will summarize the research with a list of earlier mentioned technologies that are already being used by other brand analyzed in the previous section, and how they have come out in the market.

2.4.1 Safety rules for ski helmets

2.4.1.1 Helmet types

Helmets can be divided into categories depending on the different filters to be applied: material, size, required performance, temperature exposure, external applications, versatility, etc. In this case, it is interesting to make the categorization based on how they are formed, by types of material and layers used, as the main focus is on the safety of the user ⁴.

- Integral helmets: offer total cover of the head with high quality characteristics.
- Half core helmets: lower coverage than previous ones.
- Open helmets: less protection, but still a good option for people looking for light and transpirable helmets.
- Hybrids: a mixture in between integral and half core helmets, which offer high protection but is less compact than an integral helmet.

All these types of helmets must pass some tests in order to get approved.

2.4.1.2 International Homologation

As these products provide user safety and accident prevention, they must comply with certain safety regulations. These have been categorized geographically, giving way to a regulation applicable mainly in Europe and another in the United States. Below I present the most important ones.

- European regulation **UNE - EN1077**, which is mandatory for every helmet. [ANEXES 1 DOC. UNE-EN 1077]
- United States regulation **ASTM F2040** to be able to sell in the country.
- International Ski Federation regulation **FIS RH2013** so that it can be used for competition. This rule is higher in requirements and approval phases than the previous ones since these helmets are exposed to higher intensity impact and conditions.

In addition, it can be seen that a regulation has been included for competition helmets, as it is considered that skiers in competition go at higher speeds, so the risk of contusions with greater impact also increases, and the consequences can be even more fatal than for a skier on foot.

All these rules determine the usability of the helmet based on an extended list of safety requirements it must accomplish for the consequent approval:

- The helmet can't interfere in the user's visual field.
- It must completely cover the head's sensitive areas.*

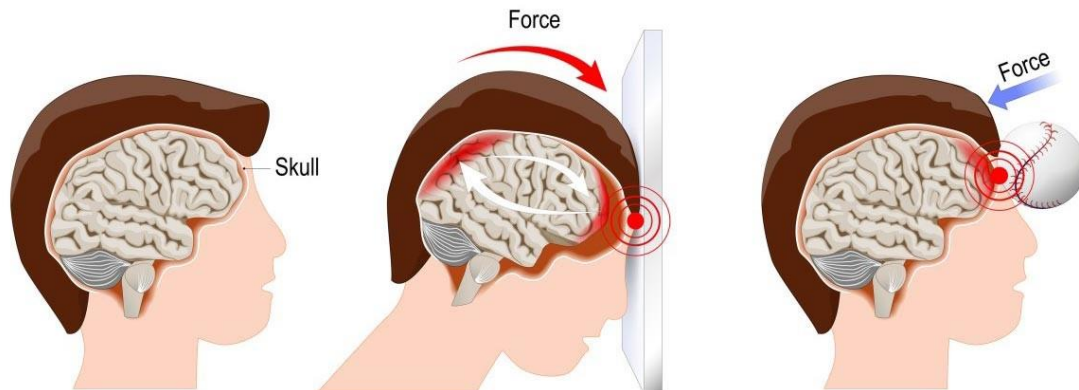

Figure 31: Front-end brain damage by high force impact

**As it is seen in this picture, the forehead and back of the head, especially the back of the neck, are the most sensitive parts in which an impact can affect.*

On one hand, the reason to take the forehead into account is because of the high quantity of blood that circulates in that part of the head, that with a high impact can cause internal bleeding that is not clear until other symptoms are already appearing.

On the other hand, the back of the neck is critical due to the proximity to the spinal column and cerebellum (organ that coordinates vital functions).

- Huge resistance to penetration and wear and tear.
- Have a high ability to withhold to the head through holding tapes.
- High capacity to absorb high impacts (the most important one).

Although the homologation protocols for security in the United States and Europe differ in some respects, it is possible to obtain quality certification under both standards.

Whether you want to learn to ski or participate in a competition, in order to choose a ski helmet, it must comply with the EN standard that authorizes its sale in Europe.

The FIS standard corresponds to competition helmets. These involve more rigorous tests conducted under parameters of higher speed. In order to choose a competition ski or snow helmet, it must obtain FIS homologation and ASTM 2040 certification.

Since the target user of this product is a skier located in the Pyrenees or the Alps, i.e. in Europe, and is a regular skier who does not compete in professional categories, the European standard will be adopted for the feasibility testing of the product.

2.4.2 Materials and Security Systems

In the quest to enhance safety in mountain sports, the materials used in the manufacture of ski helmets are crucial. This section delves into the various materials employed in helmet construction, focusing on how each material integrates with technologies to maximize user protection. The analysis considers not only the composition of the materials but also their interaction with technological innovations, ensuring high safety and performance levels in extreme conditions.

- **ABS (Acrylonitrile Butadiene Styrene):** Helmets with an outer ABS layer combined with EPS (Expanded Polystyrene) protective foam are known for their high resistance. These helmets offer less ventilation and are not the lightest, but they are very cost-effective⁵
⁶.
- **In-mold Construction:** This method involves an outer polycarbonate layer fused with an EPS filler. Helmets made with in-mold construction are ultralight and often include advanced ventilation systems⁷⁸.
- **Hybrid Construction:** Combining ABS and in-mold technologies, hybrid helmets provide superior impact resistance, safety, lightweight properties, and enhanced ventilation⁹¹⁰.
- **MIPS (Multi-directional Impact Protection System):** This additional protection system involves a low-friction layer between the ABS and EPS layers, designed to reduce rotational forces on the brain during impacts, thereby enhancing safety¹¹¹².
- **Koroyd:** Utilizing honeycomb-structured welded tubes, Koroyd technology absorbs impacts from direct or angled blows more effectively. These helmets maintain lightness and breathability, offering advanced protection¹³.



Figure 32: Example of each type of helmet described above

In conclusion, the integration of advanced materials and innovative technologies in ski helmet design significantly enhances user safety and performance. By carefully selecting and combining materials like ABS, polycarbonate, and Koroyd, and incorporating systems such as MIPS, manufacturers can produce helmets that not only meet but exceed safety standards. This developing evolution in helmet technology highlights the importance of continuous research and development to address the dynamic needs of mountain sports enthusiasts.

2.5 Internet of Things

What is IoT?

The Internet of Things (IoT) is pivotal in Industry 4.0, enabling real-time access to information via the internet and facilitating communication between various production elements, thereby enhancing efficiency and effectiveness¹⁴

Beyond customization, this new generation of products emphasizes transparency in production, allowing stakeholders to always know the status of a specific product on the assembly line. Customers can access information online about the processes, resources used, and the origin of materials¹⁵.



Figure 33: IoT mind map

This transparency has fostered a holistic approach to resource utilization, minimizing waste and promoting environmentally responsible production¹⁶.

The revolution brought by IoT would not have been possible without the internet. Factories use networks to interconnect systems, and many products now feature IoT capabilities, connecting previously unconnected objects like toothbrushes, light bulbs, cars, and combs. This connectivity has given rise to the IoT industry and a new consumption model centered around the collaborative economy¹⁷.

What Applications Does IoT Have?

There are numerous IoT applications in our daily lives that often go unnoticed:

- **Voice-controlled devices:** These make life easier at home, such as speakers that play music, security alarms that update us on our home's status when we're away, or apps that allow us to turn on the heating from our phones before arriving home¹⁶.
- **Smart appliances:** For example, refrigerators that inform us about the condition of the food they contain or the energy loss when the door is opened¹⁷.
- **Livestock farming:** Applications allow farmers to monitor the health of their animals through biometric tracking and geolocation.
- **Smart Cities and Buildings:** These can control city traffic and manage water flow through building pipes.

In addition, the application of IoT is highly valued in the design of helmets, assessing the feasibility of products and applications discovered during the research phase.

In conclusion, IoT is rapidly permeating many areas of our society. While home automation and mobile phones are the most common environments for this technology, it is increasingly common to find everyday products that now include various software applications or technological improvements.

A perfect example of this is wristwatches²⁰. The iWatch or smartwatches are now more common than the manual watches we used to know. This shift has occurred in recent years, with new features that track daily steps, heart rate, and more. People who wear these watches are seen as modern, innovative, and up-to-date. This is the message I aim to convey with the helmet and its design, which is also based on the simplicity of curved, ergonomic shapes that give a sense of cleanliness and purity.



Figure 34: Wristwatch, example of IoT applications

2.5.1 LED light technologies

In the context of technological innovation and energy efficiency, the application of LED lights^Y has emerged as a good solution. This section examines the possibilities and benefits associated with the incorporation of LED lights in mountain sports such as skiing. A list has been generated highlighting the key characteristics of LEDs, showing how each attribute contributes to the value and performance of the final product. This exploration aims to provide an understanding of the competitive advantages that LEDs can offer, from their durability to their light efficiency and environmental sustainability:

- They light up instantly.
- No overheating (practically all the electricity is converted into light and not reflected as heat), 70% in light.
- Not so fragile (withstands strong impacts and more extreme/high temperatures than a regular bulb).
- There is a wide variety of designs and colors.
- 60W of a current bulb: the LED consumes 7W.
- 50,000 hours of life/ performance capability.



Figure 35: LED light stripe

After analyzing the characteristics of LED lights, we have decided to use this technology as a presence light for users skiing in foggy or low-visibility conditions. This choice not only enhances the skier's safety by making them more visible in challenging environments, but it is also paired with a rechargeable battery system, which extends its lifespan and ensures constant operation. Thus, the combination of visibility and sustainability guarantees a safer and more efficient experience in the mountains.

2.5.2 Wireless sensors

In today's sports technology landscape, the integration of wireless electronic components in protective equipment has become a significant trend. This section focuses on identifying and analyzing various electronic components that operate wirelessly and are applicable or have already been implemented in ski helmets and other sports. Below is a comprehensive list of these components, highlighting their functions and benefits, as well as their impact on improving user safety and connectivity during sports activities.

- Bluetooth^Z to the phone: music, calls, emergency calls, etc.
- Integrated audio^{AA}: connection with phone, send information to an app.
- Telephone 3G, 4G, 5G signal to connect with others with no use of your hands.
- Velocity sensor^{AB} and STOP sensor to mark stop light, like cars.
- Temperature sensor^{AC}, to protect yourself and the technological devices.
- Weather condition sensor / weather monitoring, for light intensity.
- Falling detection: automatic notification to emergency contacts in case of falls.
- Impact protection: advanced impact absorption technology.
- Health monitoring: records heart rate and other vital signs.
- Advanced Performance Data^{AD}: Accurate movement measurement, technique analysis, and improvement recommendations.
- GPS System^{AE}: Detailed maps of slopes and off-piste routes, to avoid getting lost.
- Built-in camera^{AF}: not only to film the adventures and sky slopes, but also to probably film an accident with other skiers that can provide you with later legal information.

2.5.3 Applied technology

As seen in the market analysis section, the following list includes the technologies that brands have applied in their helmets, most of them focused on connectivity with other electronic devices or safety:

POC Aid headphones ^{AG}	
Integrated microphone and speaker	 <p>Figure 36: POC aid headphones</p>
Two-way communication through cables	
Good connectivity to phone and listening to music whilst in the mountains.	

RECCO ^{AH}	
Designed to last a lifetime, adaptable to all types of surfaces and textures	 <p>Figure 37: RECCO technology logo</p>
Emits a radar signal through a reflector that makes you detectable to rescue equipment radars	
Locatable to 80 metres in the air and 20 metres in packed snow	

Head fitting roller system ^{AI}	
Applicable on many brands of ski helmets	 <p>Figure 38: Head fitting rolling system example</p>
Adjustment system with wheels to perfect the helmet to head size ratio of the wearer	
Interchangeable in case of breakage	

Adjustable Giro Loc Roc DH System ^{AJ}	
Low friction layer designed by a neuroscientist	 <p>Figure 39: MIPS System scheme</p>
Designed to help not to force the rotational injuries while high force impacts for sports	
Has passed safety certifications ASTM F2040 snow helmet certification in the U.S., and CE EN1077 in Europe.	

In conclusion, we have decided to integrate RECCO technology into the design of the helmet, as it is a widely used product in the market that has proven effective in rescue situations. Additionally, a system similar to POC's audio will be implemented in the ear pads, allowing users to answer calls in a safe and integrated manner. This combination of innovations will not only

enhance the helmet's functionality but also provide greater peace of mind and connectivity in the mountains.

2.6 Human ergonomics

Human ergonomics, also known as human factors, is the scientific discipline that was born with understanding the interactions between humans and other elements of a system. This specialty applies theory, principles, data, and methods to design a product in order to optimize human well-being, dimensioning, and overall system performance²¹. Ergonomics englobes a variety of disciplines, including physical, cognitive, and organizational ergonomics, each focusing on different aspects of human interaction with systems and environments around them.

One notable historical application of ergonomic principles can appear going back to the work of Frederick Winslow Taylor in the 19th and 20th centuries. Taylor's scientific management approach wanted to improve industrial efficiency by analyzing and optimizing workflows. His studies on actions such as shoveling coal or loading pig iron into rail cars led to a significant productivity improvement and reduced workers fatigue²². Although Taylor's primary focus was on productivity, his methods set a path for modern ergonomic practices.

"The Design of Everyday Things" by Don Norman²³ is an interesting book that explores the principles of human-centered design and ergonomics. This book is very recommended for understanding how design can enhance usability and user experience:

- **Contact and Tactile Response**²⁴: Ergonomic design ensures that products provide a comfortable and natural fit for the user. For example, helmets designed with in-mold technology integrate the inner EPS layer with the outer polycarbonate or abs shell to create a single piece that offers perfect protection at a reduced weight. This design not only promises safety but also ensures a perfect fit that minimizes discomfort during prolonged use.
- **Product Dimensions**: The dimensions of a product must be carefully considered to match the anthropometric data of the target user population. This involves designing products that accommodate a range of body sizes and shapes, ensuring that they are accessible and comfortable for all users. In fact, the 360° Microshell in helmets wraps around the lower edge to prevent scratches and dents, providing a durable and user-friendly design.
- **Intuitive Use**²⁵: Products should be designed to be intuitive, meaning that users can easily understand how to use them without extensive instructions. This involves considering the cognitive ergonomics of the design, such as the placement of controls, the feedback provided by the product, and the overall user interface. An intuitive design reduces the cognitive load on the user and enhances the overall user experience.

By applying these ergonomic principles, designers can create products that not only meet the functional needs of users but also provide a comfortable, safe, and enjoyable experience. This

holistic approach to design ensures that products are user-centered and are focused on the variety of needs of the human body.

2.6.1 Helmet sizing

In the design of protective helmets, the ergonomics of the users' heads is an essential factor that ensures both comfort and safety. This section will focus on considering cranial ergonomics to establish precise measurement restrictions in helmet design. Current technologies and measurement systems, already applied in the helmet industry, will be taken into account to ensure an optimal and personalized fit. Through this list, I develop designs that not only provide effective protection but also adapt comfortably and securely to the anatomy of each user.

Human head measurements²⁶.

To measure the main dimensions of the human head from which to design the helmet's main figure, the following measuring table has been considered:

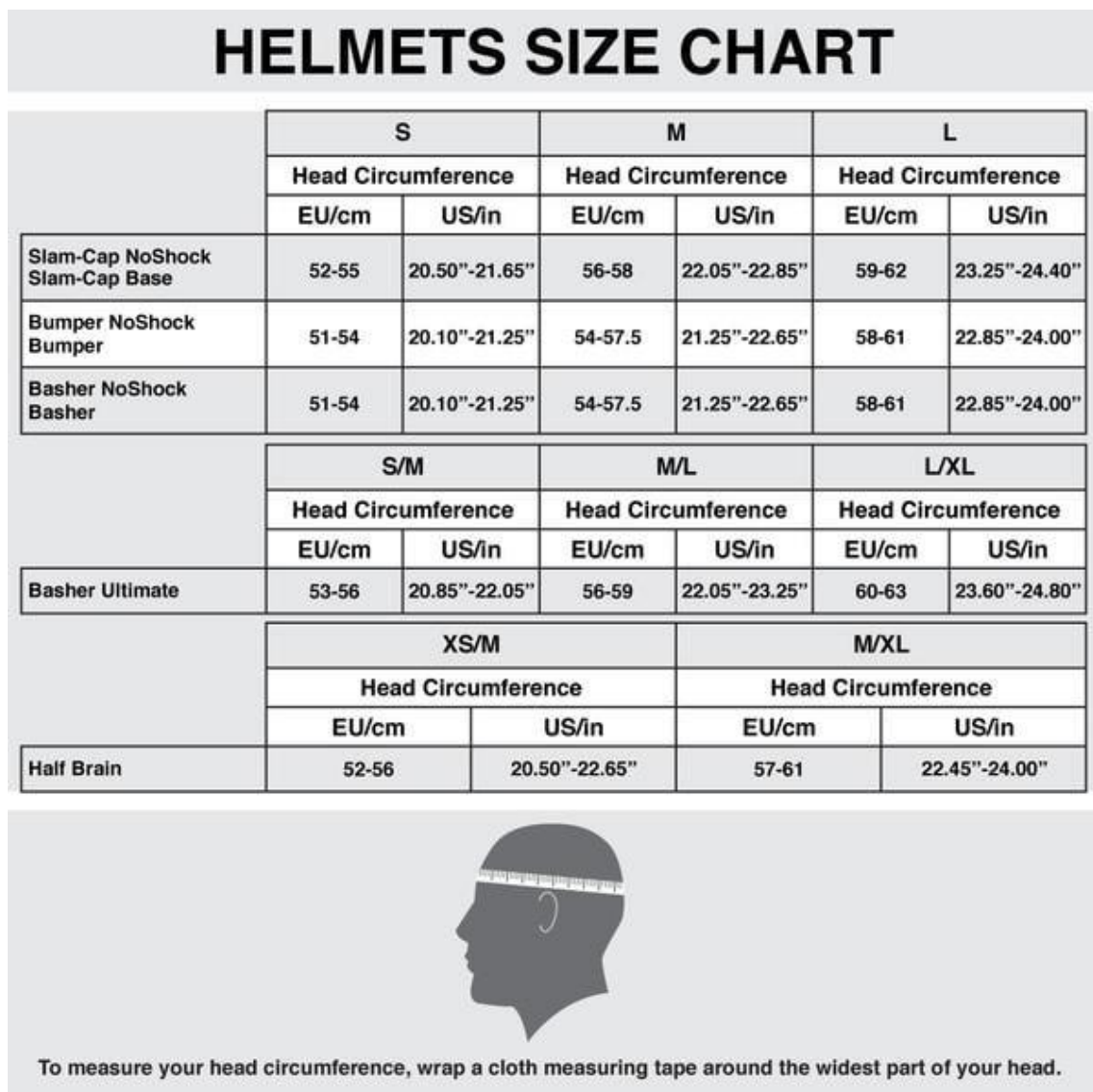

Figure 40: Human head measurements and reference for helmet charts

With this, it has been decided to take the S/M size of a regular head to design the outside shell of the product. MIPS system and other size-adjustable applications are later inserted in the design.

While taking the measurement of the head into account, it is also valuable to see the material that is going to be in direct contact with the head, as it does occupy a lot of space and has to be comfortable. The surface in direct contact with the user's head will be an adaptative foam, in order to make the transition from head to helmet much softer. Foam is also non-slippery, which is important for the correct functionality while being used.



Figure 41: Stripe around head to measure size

An adjustable Giro Loc Roc DH System^{AI} is a thing to be considered as an option for implementation, as it will help the size be more accurate to the user's head and so the product performs much better.

2.6.2 Color analysis

The choice of color in ski helmet design is not simply an aesthetic decision but also a functional one. This analysis aims to explore the most commonly used colors in ski helmets, their popularity trends, and the psychological and practical implications of each color. Understanding these factors is crucial for designing a product that not only appeals to consumers but also enhances their safety and performance on the slopes.



Figure 42: Multicolor POC helmet

The most commonly used colors in ski helmets include black, blue, red, and yellow. These colors are chosen not only for their visual appeal but also for their functional benefits. Bright and bold colors, such as neon green, pink, and orange, are also gaining popularity due to their high visibility on the slopes.

Psychological and Practical Implications ^{27 28}

- **Black:** Often associated with power, sophistication, and elegance, black is a popular choice for those who want a sleek and modern look. However, it can be less visible in low-light conditions, which is a critical consideration for safety.
- **Blue:** This color evokes a sense of calm, trust, and stability. It is often chosen for its association with the sky and snow, providing a tranquil and confident feeling for skiers.
- **Red:** Known for its energy, passion, and excitement, red is a bold choice that helps skiers stand out. It can attract attention, which is beneficial for visibility but may also draw unwanted attention.

- **Yellow:** Representing happiness, warmth, and optimism, yellow is excellent for visibility in low-light conditions. It is a playful and fun color that enhances safety by making the wearer more noticeable.
- **Pink:** Associated with love, compassion, and playfulness, pink is a cheerful color that can add a touch of fun and individuality. It is also quite visible, making it a good choice for safety.
- **Orange:** Symbolizing enthusiasm, creativity, and adventure, orange is a vibrant color that stands out. It is highly visible and can evoke a sense of excitement and energy.
- **Green:** Representing nature, growth, and harmony, green is a calming and refreshing color. It can provide a sense of balance and tranquility, and it is also quite visible in various environments.



Figure 43: POC-ito bright ski helmet colors

Relation to Skiing

The choice of color in ski helmets is closely related to the sport's demands. High visibility is crucial for safety, especially in crowded or low-visibility conditions. Bright colors help skiers stand out against the white snow, reducing the risk of collisions. Additionally, the psychological effects of colors can influence a skier's performance and confidence on the slopes.

In conclusion, the color of a ski helmet plays a significant role in both aesthetics and functionality. Popular colors like black, blue, red, and yellow each offer unique benefits and convey different psychological messages. Bright and bold colors enhance visibility and safety, which are paramount in skiing. By understanding these factors, I can create ski helmets that not only meet safety standards but also appeal to consumers' preferences and upgrade their overall skiing experience.

2.6.3 Tactile analysis

The design of ski helmets with advanced technology focuses not only on safety and functionality but also on the tactile experience and textures they offer. This section analyzes how textures and tactile sensations influence the design and use of ski helmets, integrating technology to enhance the user experience.

Textures in ski helmets play a crucial role in the user's perception of quality and comfort. Smooth and well-finished surfaces can convey a sense of high quality and durability, while rough textures can provide better grip and stability when adjusting the helmet. Additionally, textures can influence ventilation and heat management, which are essential for maintaining comfort during prolonged use in cold conditions²⁹.

The tactile experience is fundamental to user comfort. A helmet that feels comfortable to the touch and does not cause irritation or discomfort is more likely to be used correctly and for longer periods. The materials used inside the helmet, such as padding and liners, should be soft and breathable to prevent sweat accumulation and keep the user's head dry and comfortable³⁰.

The inclusion of technology in ski helmets, such as communication systems, impact sensors, and audio devices, requires careful consideration of textures and the tactile experience. Touch controls should be intuitive and easy to use even with gloves, and technological components should be integrated in a way that does not compromise the comfort or safety of the helmet.

To evaluate the tactile quality of a ski helmet, user tests should be conducted under real-use conditions. These tests can include assessing comfort during prolonged skiing sessions, ease of adjustment, and overall perception of the textures and materials used. User feedback is essential for improving the design and ensuring that the helmet is not only safe and functional but also pleasant to the touch.

In conclusion, considering the aspects mentioned in this section, I will do my best to convey between good quality materials with a good finished touch for tactile experience, specially in the surfaces in direct contact with the human head or hands while managing these surfaces (on/ of button for example).

2.7 Conclusions

In this section, both the type of person the product is referred at and a list of requirements that this target user would want the designed product to have been analyzed. Additionally, a

thorough market analysis regarding the safety regulations the product must comply with has been conducted. Furthermore, existing technological applications in other products considered as competitors, as well as applicable technologies, have been evaluated.

2.7.1 Persona

These latter points are interesting to address the first point mentioned: the requirements that the target user seeks in the product can be met with existing products or technologies. Below is the list of requirements along with the included technological responses:

ALPINE SKIER: MIDDLE LEVEL - FAMILY SKIER

- Communication: Connectivity with mobile devices for calls and messages. - Connectivity Technology.
- Integrated Audio: Music playback and communication with other skiers. - Audio equipment.
- Enhanced Visibility: Integrated LED lighting and reflectors. - LED light / Presence sensor.
- Emergency Communication: Ability to send distress signals and exact location. - RECCO.
- Impact Protection: Advanced impact absorption technology. - Material and Design (MIPS).
- Total Protection: Complete head and face coverage with padded and comfortable materials.- Material (EPS) and Design.
- Durability: Strong and lightweight materials that withstand extreme conditions. - Materials. EPS and ABS
- Affordable Cost: Good balance between functionality and price. - Cost (Material and manufacturing processes).
- Comfort and Style: Attractive and comfortable design for prolonged use. - Design.



Figure 44: Persona image

3. PRODUCT POSITIONING. DEFINITION PHASE

3.1 SWOT analysis

Having completed the market and competitor analysis in the previous section, we now move on to conduct the SWOT analysis, emphasizing both positive and negative aspects that need to be considered when positioning the product to be designed. The following are the four aspects analyzed, followed by a conclusion that influences the decision presented in the next section:

Strengths	Weaknesses
<ul style="list-style-type: none"> - Innovative: combines high technology with traditional safety features, setting it apart from standard helmets. - All-in-one: integrates multiple functionalities such as communication and safety features into a single device. - Safety as the main advantage: equipped with sensors, lights, and enhanced visibility features to ensure maximum safety on the slopes. - Enhanced communication: built-in communication systems allow skiers to stay connected with their group. - Comfort to ensure comfortable fit for extended use. Based on used materials and finishes. 	<ul style="list-style-type: none"> - Failure of sensors/electrical devices: potential for malfunctioning sensors or electrical components, which could compromise safety. Also breakage. - Information overload: excessive data might overwhelm the user, leading to distraction rather than assistance. - Visibility issues: Despite technological enhancements, the helmet might still be less visible to others on the slopes, especially in poor weather conditions. LED light should be a high power light. - Harsh weather conditions: extreme cold could affect the functionality of the electronic components. - Isolation of electrical devices: ensuring the electrical components are well-protected and insulated within the helmet can be challenging.
Opportunities	Threats
<ul style="list-style-type: none"> - Growing demand for safety: increasing awareness and demand for safety gear among skiers. - Smart action-reaction functions: advanced features that automatically adjust settings based on real-time conditions, simplifying use and enhancing safety. - Cross-sport technology application: leveraging technologies from other sports to enhance the helmet's functionality and reliability. 	<ul style="list-style-type: none"> - Technological competitors: other companies specializing in wearable technology could introduce similar or superior products. - High price point: the cost of incorporating advanced technologies may result in a higher price, potentially limiting market reach. - Established brands: competing with well-known ski helmet brands that have a strong market presence and customer loyalty.

<ul style="list-style-type: none"> - Customization options: offering personalized features and designs to cater to individual preferences and needs. - Partnerships with ski resorts: collaborating with ski resorts to promote and distribute the helmet, increasing visibility and adoption. 	<ul style="list-style-type: none"> - Market saturation: the presence of numerous safety and technology products in the market could make it challenging to stand out. - Regulatory challenges: ensuring compliance with safety and technology regulations in different regions could pose challenges.
--	---

Table 1: SWOT analysis of product design

In summary, the advanced ski helmet combines innovation and safety with features like sensors, communication systems, and real-time feedback. It has many benefits, such as improved safety and multifunctionality, but also faces challenges like possible electronic failures and information overload for the user. The market opportunities are promising, driven by increased safety awareness and the potential to use technologies from other sports. However, the product must navigate threats from technological competitors, established brands, and high costs. Careful management of these factors is essential to ensure the product's success in the competitive market..

3.2 Product Positioning Chart

In the product positioning section, two key parameters have been considered: the inclusion of smart applications and safety. These criteria were chosen based on the features and functionalities observed in the ski helmets analyzed during the market study. The integration of smart technologies not only provides a more connected and personalized experience for the user but also adds a distinguishing value compared to competitors. Additionally, safety remains a crucial priority, ensuring the skier's protection and well-being. For this comparison, the helmets considered in the market research have been taken into account.

This strategic positioning aims to highlight our ski helmet as an innovative and safe option in the current market and helps to decide which already existing helmets might be an inspiration for the current product design and constraints. As it is visible, Atomic and POC are two inspirational brands in which to base the new helmet design.



Figure 45: Product positioning chart

3.3 Kpi's

Once the exact user for whom this design is intended has been defined, a second list of characteristics has been generated, this time defined as kpi, with which the characteristics that we want this helmet to have in a quantitative way are developed. The list is shown below:

- It must be comfortable, as a "soft texture" on the head and that can fit almost any head shape with just adjusting the size with the roller in the back.
- It must have an intuitive use, in some respects:
- To put it on fit on the head + click in the chin to close + adapt to size (maximum number of steps must be 3).
- To take it off: click on the chin and take it off.
- There must be a clear on/off button to switch the LED light fixture, independent to the rest of the technologies.
- The recharging system must be intuitive (USB-c entry that everybody understands, for example).
- The other devices should have an on/off visible button for their own compliance system, independent from the LED light.
- There must be a ventilation design, to be a helmet that fits any season and (almost) any temperature, so that the traditional alpine skier can have this product exclusive for every occasion.
- The total weight (including technological devices) must oscillate between 500 and 700 grams.
- The total price of the product could go from 150€ to 550€.

With these lists, a very specific definition of the technologies that need to be considered when designing the product can be generated, considering space, weather conditions, durability, interest in the product's longevity or versatility, etc. Additionally, this provides a satisfactory conclusion to the market analysis section, which connects to the next section, where the product is analyzed in greater depth.

3.4 Conclusions

The SWOT analysis of the technologically advanced ski helmet underscores a unique fusion of innovation and safety, incorporating state-of-the-art features such as sensors, communication systems, and real-time feedback mechanisms. This innovative approach not only enhances the helmet's functionality but also ensures a higher level of safety for users. The strengths of the helmet are evident in its high-tech integration, multifunctionality, and comfort, which collectively set it apart from conventional helmets.

However, the analysis also highlights several challenges. Potential electronic failures and information overload are significant concerns that could impact user experience and safety. These weaknesses necessitate robust design and engineering solutions to mitigate risks and ensure reliability under various conditions.

The market presents promising opportunities, driven by a growing awareness of safety and the potential to incorporate technologies from other sports. Customization options and strategic partnerships with ski resorts further enhance the product's appeal and market penetration. Nevertheless, the helmet must navigate a competitive landscape with technological rivals, high production costs, established brands, and stringent regulatory requirements.

In conclusion, while the ski helmet is positioned as an innovative and safe option in the market, its success will hinge on effectively managing its weaknesses and threats. By capitalizing on market opportunities and addressing potential challenges, the product can achieve a competitive edge and meet the evolving demands of safety-conscious consumers.

4. IDEATION AND PROTOTYPING

4.1 Brainstorming

To carry out this brainstorming session, I started by deciding about what we want to include in the helmet. Among other things, I thought it was important to mention both technology applications that make the helmet "smart", and safety features. All these applications are elements that already exist in the market; nothing new is being created. We are simply generating a new system of combinations that align with the initial briefing and that beneficially meet the needs/requirements of the user who has been defined as the "base" for whom this product is being designed.

- MIP technology is an important constraint to take into account for this design, in case it is possible to integrate.
- An optional helmet size alignment is being considered. This could be disrupted by the MIP system.
- A presence of LED light, if possible detachable to charge outside the helmet.
- RECCO technology and impact sensor TBD depending on design restrictions.
- Bluetooth - phone connection - headphones for communicating with others: insert on earpads.
- Might think of a design in where the technology is totally integrated and not detachable and include a charging port in the helmet itself.
- Looking for clear color and lines, smooth design lines and cohesion between shapes and colors.

4.1.1 Moodboard

Mood board for physical design inspiration inserted down below.

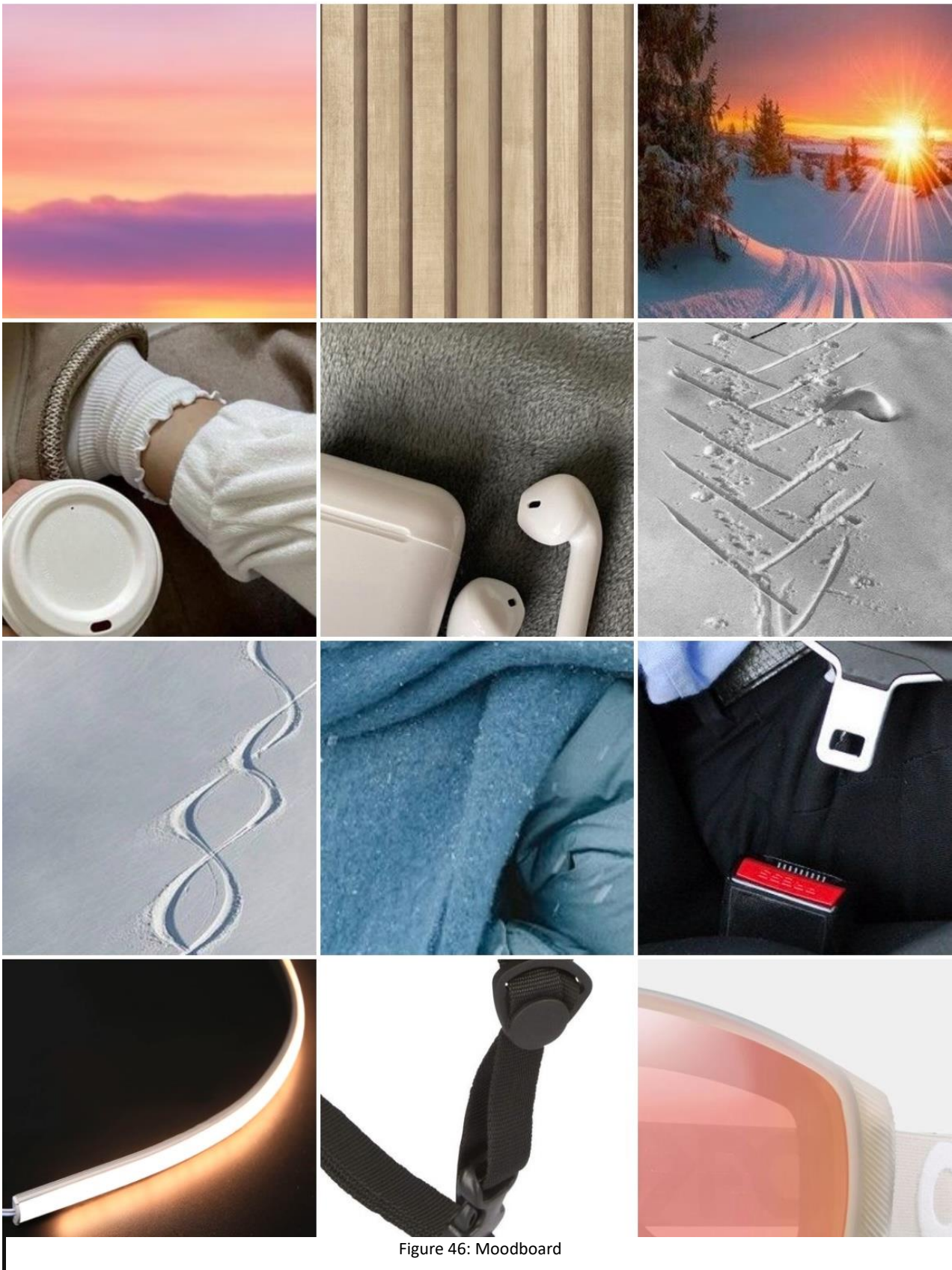

Figure 46: Moodboard

4.2 Main ideas development

After conducting the brainstorming session on possible designs and technology applications, the most advanced design was chosen. In this design, the "kit" of electronic devices can be removed from the model for individual charging, and if desired, the user can opt not to use this application center, allowing the helmet to function solely as head protection during sports activities.

The development of the idea is explained in more detail below:

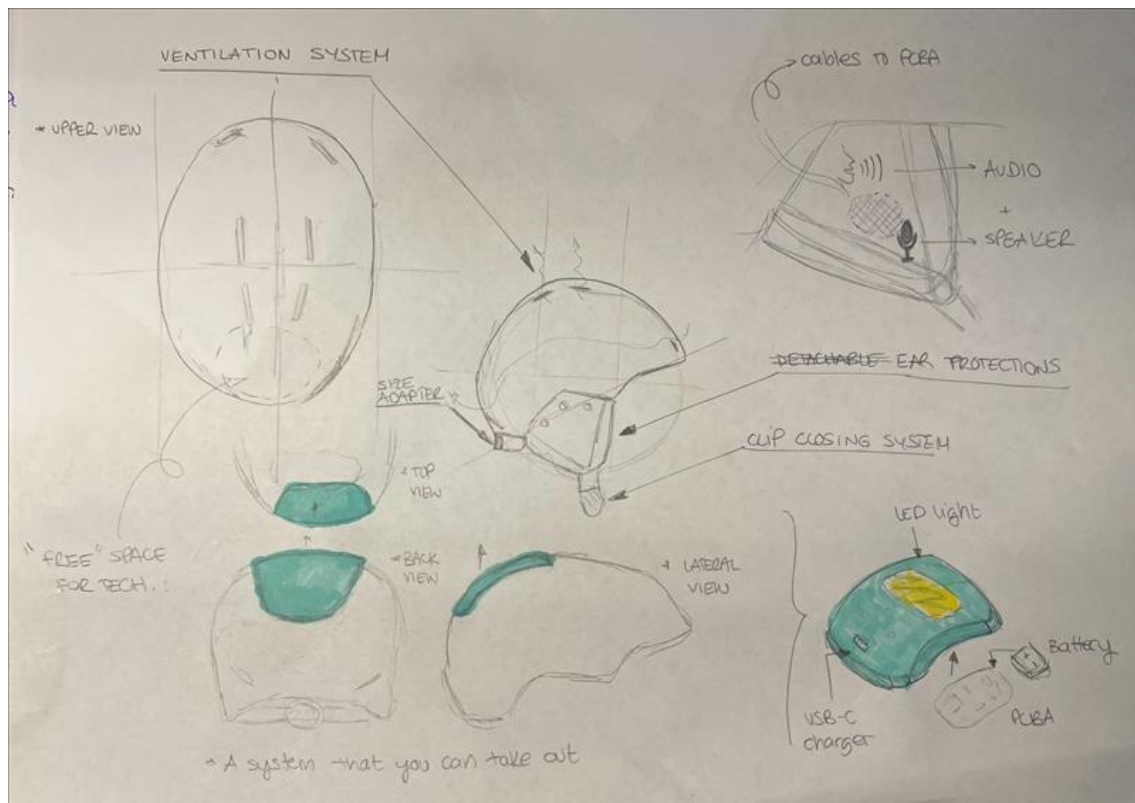

Figure 47: Idea 1 first drawing

This first idea involves placing the devices such as presence sensors, LED lights, Bluetooth connectivity, and everything needed for a PCB station inside a box that would be located at the crown of the helmet. In this way, the user can remove this part once at home and charge it wirelessly in a dry place, and then reattach it to the helmet when it is ready to be used. This system includes a clip mechanism to securely attach and remove the component from the helmet shell, ensuring it is securely fastened and protected against impacts.

Pros

- Convenience: The removable box allows for easy charging at home, making it user-friendly.
- Wireless Charging: Charging the device wirelessly in a dry place ensures safety and ease of use.
- Modularity: The ability to detach and reattach the component provides flexibility and ease of maintenance.

- **Secure Attachment:** The clip mechanism ensures the component is securely fastened, reducing the risk of it falling off.
- **Protection:** The design protects the devices against impacts, enhancing durability.

Cons

- **Complexity:** The inclusion of multiple devices (sensors, LED lights, Bluetooth) may complicate the design and increase the risk of malfunctions.
- **Weight:** Adding a box with multiple devices at the crown of the helmet could increase the overall weight, potentially affecting comfort.
- **Cost:** Incorporating advanced features like Bluetooth connectivity and wireless charging may increase the production cost.
- **Aesthetics:** The box might affect the helmet's appearance, making it bulkier or less streamlined.
- **Reliability:** The clip mechanism, while secure, may wear out over time, potentially compromising the attachment.

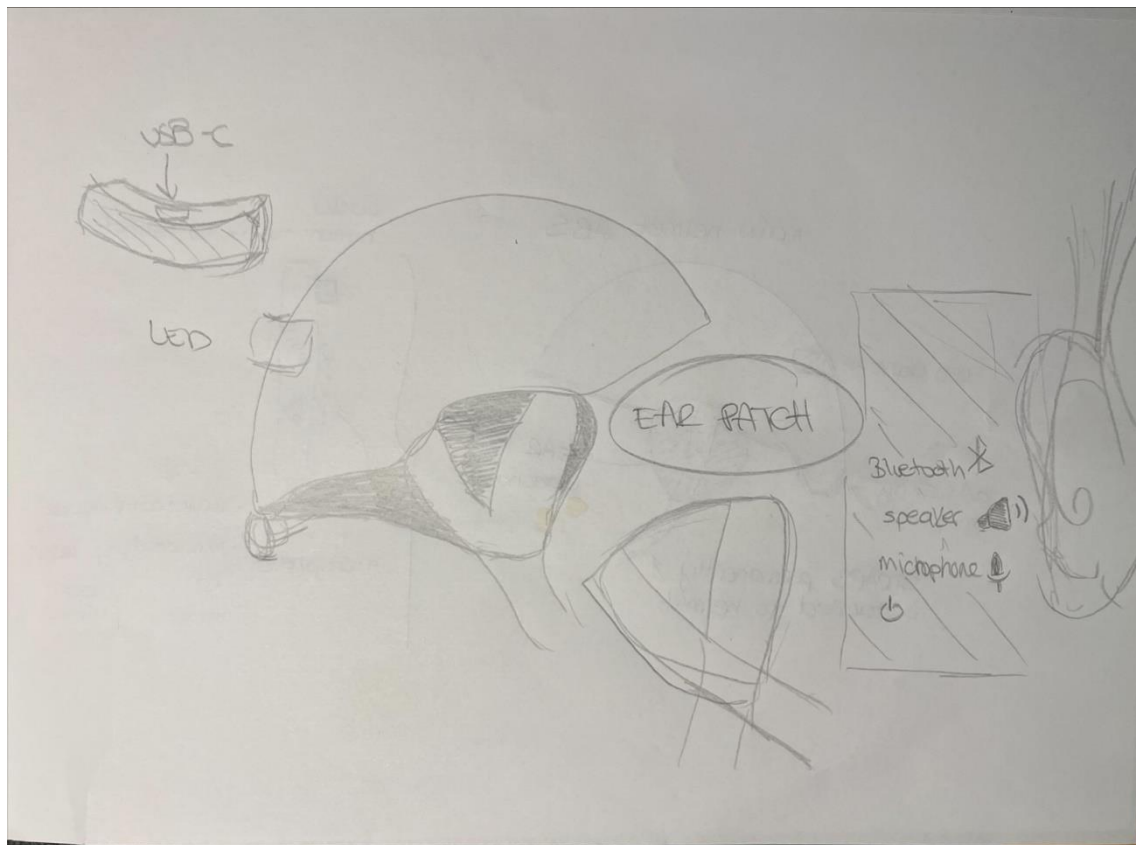

Figure 48: Idea 2 first drawing

This second idea is similar to the first one: a fastening system that allows the electronic devices to be charged wirelessly during non-use hours. However, in this case, the electronic devices will be placed in the ear cups, enabling the integration of a phone connection system so that the user can stay in contact with their phone if necessary. Additionally, the LED light would be attached to the exterior of the helmet, similar to the LED lights available on the market for

bicycle helmets. In this case, the exterior of the helmet would not be affected by the electronic devices, allowing the design to be much sturdier and more effectively meet European and global safety regulations.

Pros

- **Wireless Charging:** Allows for convenient charging during non-use hours.
- **Phone Connectivity:** Integration of a phone connection system in the ear cups enables the user to stay connected.
- **LED Light Placement:** Attaching the LED light to the exterior, similar to bicycle helmets, enhances visibility and safety.
- **Sturdier Design:** The exterior of the helmet remains unaffected by electronic devices, making the design more robust.
- **Compliance:** The design can more effectively meet European and global safety regulations.

Cons

- **Complexity:** Integrating phone connectivity and other electronics in the ear cups may complicate the design.
- **Weight Distribution:** Placing electronics in the ear cups could affect the helmet's balance and comfort.
- **Cost:** Advanced features like phone connectivity and wireless charging may increase production costs.
- **Maintenance:** The ear cup electronics might require more frequent maintenance or repairs.
- **Aesthetics:** External LED lights might alter the helmet's appearance, potentially making it less streamlined.

- Given these two design branches, a comparative list has been generated for both to see which one might better align with the continued development of the helmet.

Comparative list of both ideas

POSITIVE ASPECTS ON BOTH

Feature	First Idea	Second Idea
Convenience	Easy charging at home	Convenient wireless charging during non-use hours
Wireless Charging	Yes	Yes
Modularity	Removable box for flexibility	Integration in ear cups for phone connectivity
Secure Attachment	Clip mechanism ensures secure fastening	Sturdier design with unaffected exterior
Protection	Protects devices against impacts	Meets European and global safety regulations
Phone Connectivity	Not mentioned	Integrated phone connection system

LED Light Placement	Not specified	Attached to the exterior, enhancing visibility
----------------------------	---------------	--

Table 2: Positive aspects of both design paths

NEGATIVE ASPECTS OF EACH IDEA

Feature	First Idea	Second Idea
Complexity	Multiple devices may complicate design	Integrating electronics in ear cups may complicate design
Weight	Increased weight at the crown	Potential imbalance due to electronics in ear cups
Cost	Higher due to advanced features	Higher due to advanced features
Aesthetics	Box might affect appearance	External LED lights might alter appearance
Reliability	Clip mechanism may wear out	Ear cup electronics may require more maintenance

Table 3: Negative aspects of both design paths

Having assessed both design options, it has been decided to go for the second option, so that the light can be switched on when needed and if not, the helmet is in normal use. As mentioned above, this makes it easier to ensure that the helmet complies with the safety and hardness standards mentioned above, as it has no ‘parts that could become detached in the event of an impact’.

In addition, mobile technologies and RECCO security system are always still present. The summary of these technologies already brings an innovation to the product.

4.3 Final Design definition

Having assessed the standard measurements for 95% of the user's head size (55-65cm head circumference), we have designed the size of the helmet, with its corresponding expanded propylene coat, MIP systems and the inner padding that gives the product its softness and comfort.

The LED light is a detachable feature located at the crown of head in order to make it visible for the rest of the skiers in the slopes. In order to integrate this design in the helmet main shape and not make it outstand too much, the idea is to insert it inside the main structure of the ABS shell.

The earmuffs, which include the hearing system (inspired by the Aid POC System), are removable with a system of buttons on the inside of the helmet, so that they can be easily removed and put on, and the device can be charged.

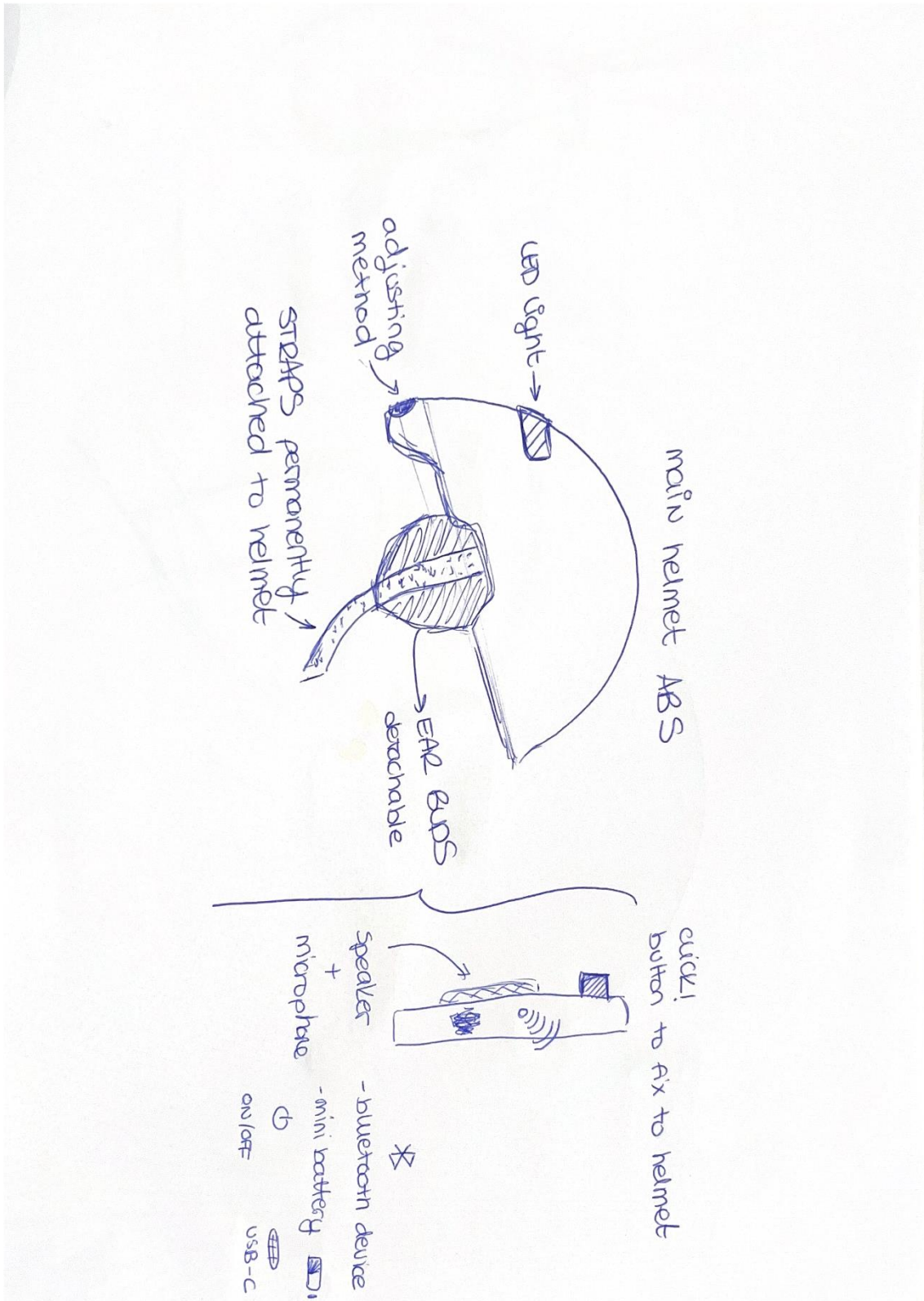

Figure 49: Main sketch of future development idea

This also demonstrates the ease of use of the helmet, which complies with the three steps to put it on and two to take it off set out in the previous kpi features.

In the table shown in the Bill of Materials section below, the weight of each technological product that is applied is shown, together with its price and the corresponding weight and price sums, to corroborate compliance.

Below are more pictures of the sketches with the final design of the product.

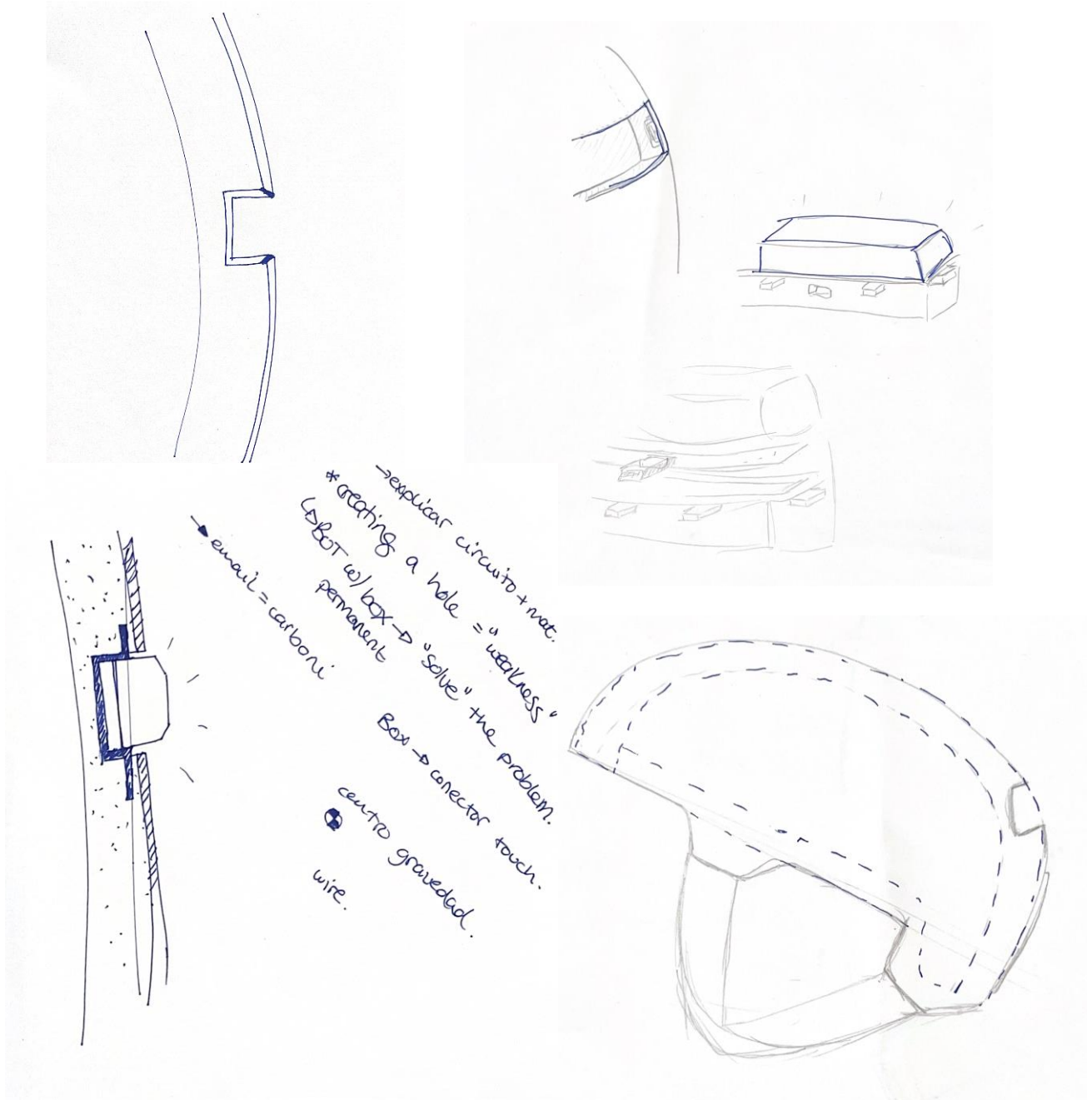

Figure 50: Main idea sketches

5. FINAL PRODUCT PROPOSAL

5.1 3D model

The 3D model of the presented product shows only the parts that are to be designed exclusively for this product, so space is left to insert the technologies where appropriate, but they do not appear in the assembly.

- The designed parts are mainly three: helmet shell, integrated MIP system, inner cushion pads and ear muffs.
- The little BOX for de LED light, together with the Assembled PCB and electronical devices interaction center, connected to a portable battery, USB-C input for charging the battery, and cables to the microphone and speaker.
- The 'shell' includes a slotted ventilation system, LED light integration system in the crown area, and a push-button attachment system for the earmuffs.
- The MIP system is an adaptation of the system used by POC.
- The earmuffs are based on the side-cut shape of the helmet shell design, a button system together with the microphone and speaker devices, and the straps for attaching the helmet in the jaw area, which can be inserted into the padding and helmet.
- The inner pads are glued to the MIP system, so that they do not detach from the safety system at any time.

5.1.1 General explanation

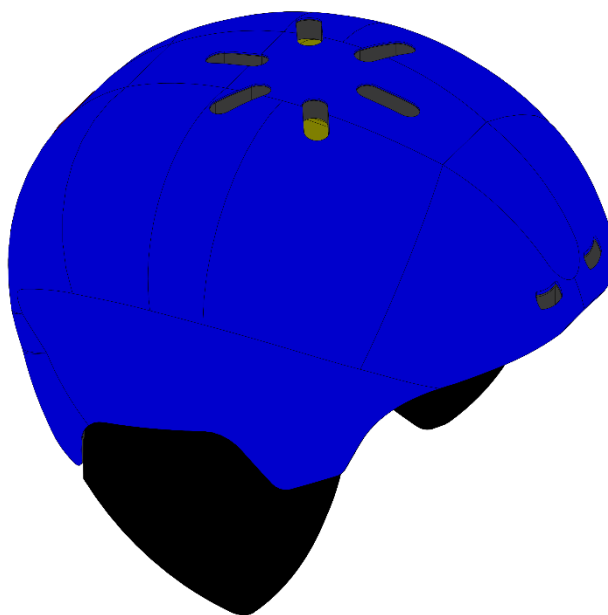

Figure 51: 3D model isometric view

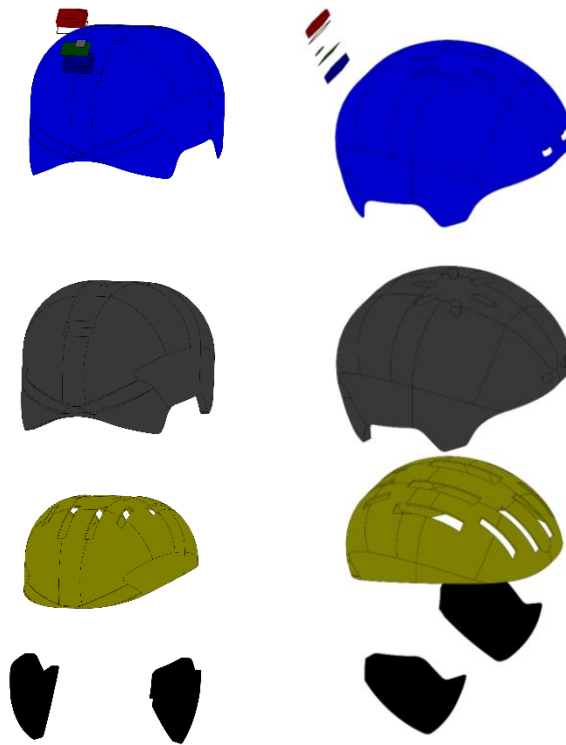

Figure 52: Exploded view for design parts

As can be seen in the following images, the model is made up of several parts: some of them manufactured specifically for this model, and other electrical parts already manufactured as standard.

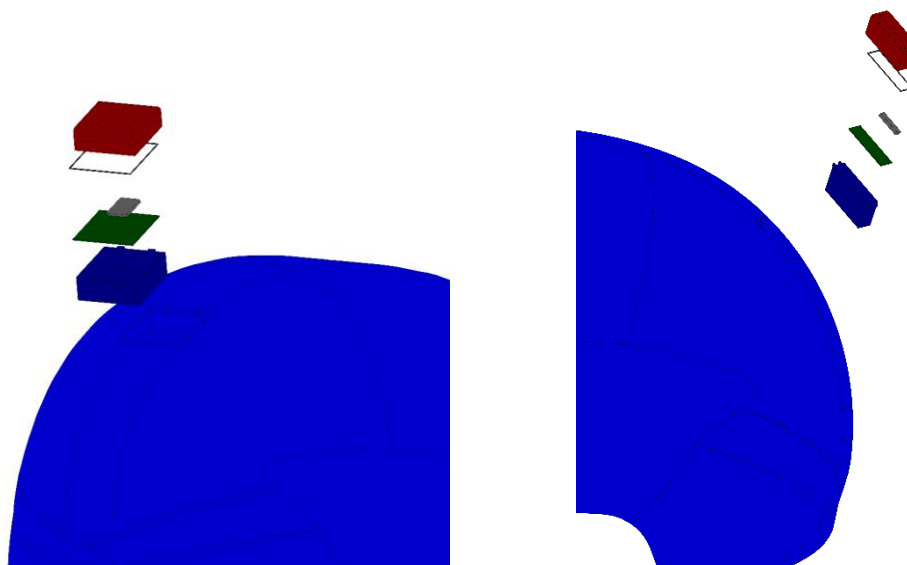

Figure 53: Detailed exploded view of LED case

The standard parts have been selected based on the basic measurements that a preliminary 3D design required: for reasons of space and organization of elements so that they make sense for their distribution and execution.

The parts designed specifically for this helmet, which are the aforementioned housing, LED light box and the entire PCBA system incorporated in this box, clip system to remove and put on this box, present drawings of the assembly together, exploded, and the individual parts.

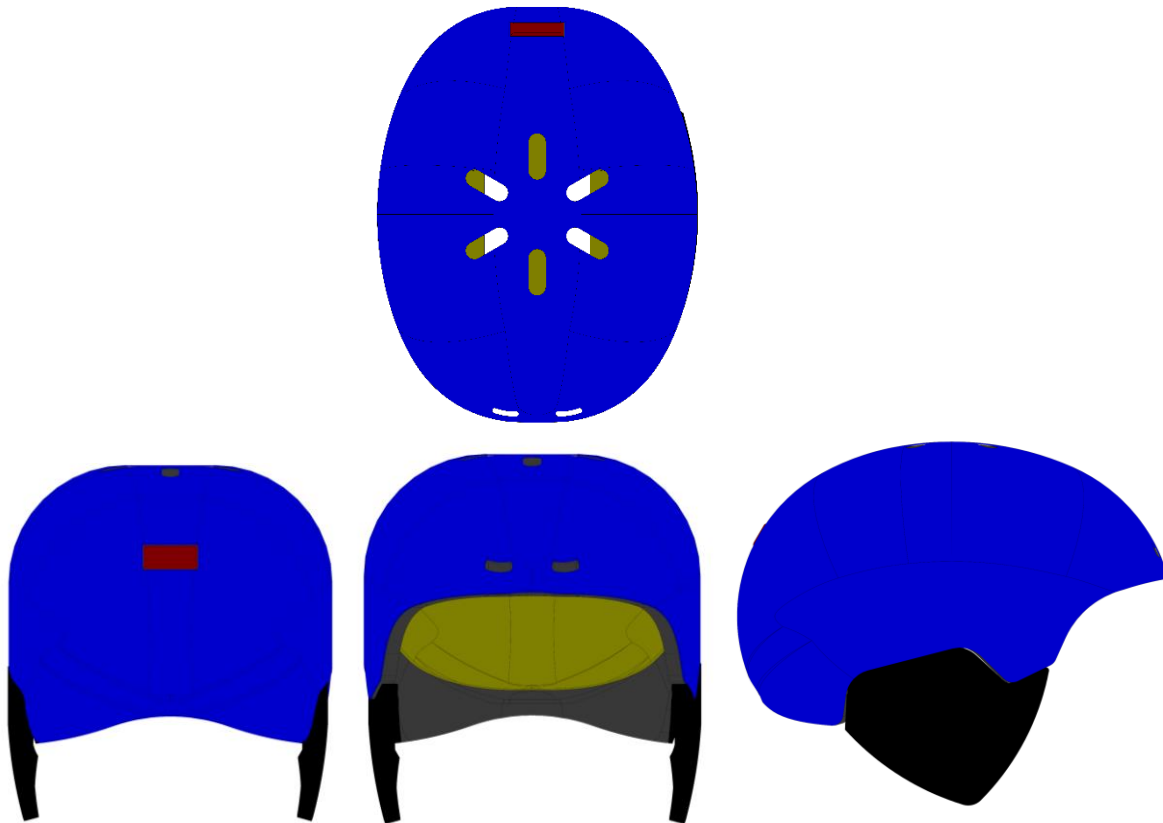

Figure 54: Helmet assembly front, lateral and top views

The electronics are as listed in section 4.1 and are state of the art in their specialty for high impact sports.

5.1.2 Detailing

As part of the design process, small changes have been made to improve the design and adapt it to the needs of the design. For example, as explained, a box-like 'hole' has been made in the outer shell of the helmet, or a box in which to put the LED lights, PCB and other electronic components that are attached here. In order for this pocket to be able to somehow 'hook' into the housing without it coming out at the slightest movement, snap-fits have been made, suitable for a small, easily removable hook. This can be seen in the drawing of the model [ANNEX 7. TECHNICAL DRAWINGS].



Figure 55: LED light box lateral view for snap-fits

In addition, small slits have been included to insert these snap-fits into the box that surrounds the EPPS foam of the helmet, so that the snap-fit can be inserted without any problem.

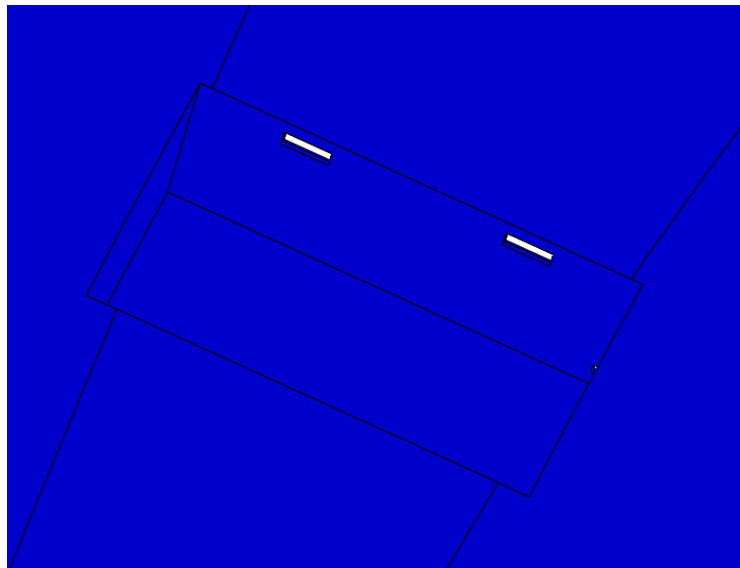

Figure 56: ABS / PC shell box slits to insert snap-fits

Once this has been incorporated, the problems have been others: the main one has been to create a wiring to connect the PCB with the electronic devices that go in the earmuff, for which it has been chosen to do everything on the right side since a very high percentage of the population is right-handed and will handle the devices better with this side while skiing. For this purpose, a hole has been cut both in the light box and in the enclosing wall of the housing. This is ensured by a line drawn along the foam from the light box to the earmuff in question.

For this last design decision, it has been decided not to make the earmuff removable: it could cause problems with the wiring. In addition, a wiring connector has been included so that, when

you want to remove the box to charge the battery, you don't have to move the cable and when you reinsert the box, the circuit will make contact again and everything will be reprogrammed.

Returning to the design of the housing and snap-fits, a small protrusion on the housing has been designed so that it can be grasped with two fingers, squeezed inwards (thus helping to intuitively disconnect the snap-fits between the housing and the housing), and pulled outwards to remove everything. This provides an intuitive yet unobtrusive system for getting the case in and out during helmet use.

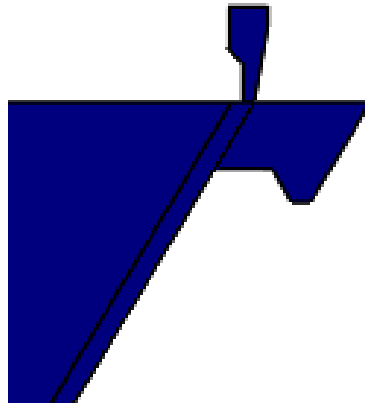

Figure 57: Zoom in to LED case snap-fits

In addition, and in line with the ergonomic analysis of the tactile part that the user appreciates (especially when he cannot see what he is handling), the ON/OFF button of the whole system will be located on the ear cup. This way, the user can use his hand to click on a button (which will have some relief under the padding to make it easy to find) and turn on the whole system. These are the aspects of the design explained, although this data can be seen graphically reflected in the next sections of the modes of use and/or technical drawings.

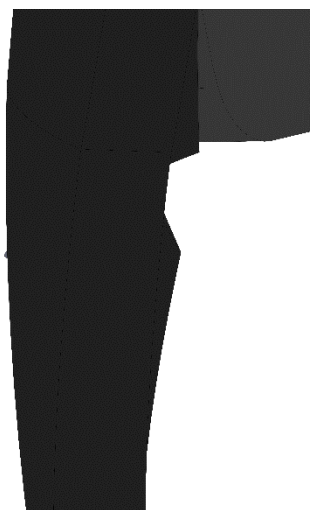

Figure 58: On/ Off button tactile relief vision

5.2 Material selection

This section details the analysis and selection of the most suitable materials for designing a ski helmet with smart applications, such as lights and sensors. Choosing the right materials is crucial to ensure both user safety and the efficient integration of smart technologies. The analysis is divided into two main parts: materials for the outer shell of the helmet and materials for the inner lining, which is in direct contact with the user's head. Each material will be evaluated based on its properties, advantages, and disadvantages, to select the most appropriate one for each specific use.³⁰

A. Materials for the Outer Shell of the Helmet

- Polycarbonate (PC)

Pros: High impact resistance, lightweight, good distribution of impact force, easy to mold.

Cons: Can scratch easily, less resistant to chemicals.

- Acrylonitrile Butadiene Styrene (ABS)

Pros: Excellent durability, good impact absorption, resistant to chemicals.

Cons: Heavier than polycarbonate, can become brittle at low temperatures.

- Fiberglass

Pros: High strength and durability, excellent impact distribution.

Cons: Heavier than plastic materials, more expensive, can shatter on very strong impacts.

- Carbon Fiber

Pros: Extremely lightweight, very strong, excellent impact absorption.

Cons: Very expensive, more difficult to produce and repair.

B. Materials for the Inner Lining of the Helmet

- Expanded Polystyrene (EPS)

Pros: Excellent impact absorption, lightweight, affordable.

Cons: Does not handle multiple impacts well, can crumble over time.

- Expanded Polypropylene (EPP)

Pros: Good impact absorption, more durable than EPS, resists multiple impacts.

Cons: More expensive than EPS, slightly heavier.

- Polyurethane Foam

Pros: Good impact absorption, comfortable for the user, versatile in density.

Cons: Less durable than EPS and EPP, can lose shape over time.

For the outer shell of the helmet, a combination of **Acrylonitrile Butadiene Styrene (ABS)** and **Polycarbonate (PC)** is selected due to their high impact resistance and lightweight properties, which are essential for a ski helmet that incorporates smart technologies. Additionally, the ease

of molding these materials allows for better integration of technological components, ensuring both durability and functionality.

For the inner lining of the helmet, **expanded polypropylene (EPP)** is chosen for its ability to withstand multiple impacts and its superior durability compared to other materials. Although it is slightly more expensive, its additional resistance offers better continuous protection for the user.

5.3 SolidWorks Simulations

Once the 3D model had been made, a structural analysis of the hull shell was carried out. This is because, during the design and modelling phase, the need arose to confirm the feasibility of the design with this cut-out in the crown area of the head: the case must meet certain standards in order to be marketed in Europe.

For this analysis, SolidWorks Simulations has been used. The analysis has been mainly structural, to which some external forces have been applied, both in areas where the user can receive strong blows when falling (frontal area above all, it is also the most critical to receive impacts and possible consequent bruises), and a fortuitous impact near the 'hole' of the LED light, which risks cracking or breaking the helmet.

SolidWorks has produced a document [ANNEX 2. SOLIDWORKS SIMULATIONS. STATIC SIMULATION.] in which it can be seen that the results are very positive, so this ski helmet shell design is approved, and it can be said with certainty that it is a safe helmet.

A summary of the document is shown below:

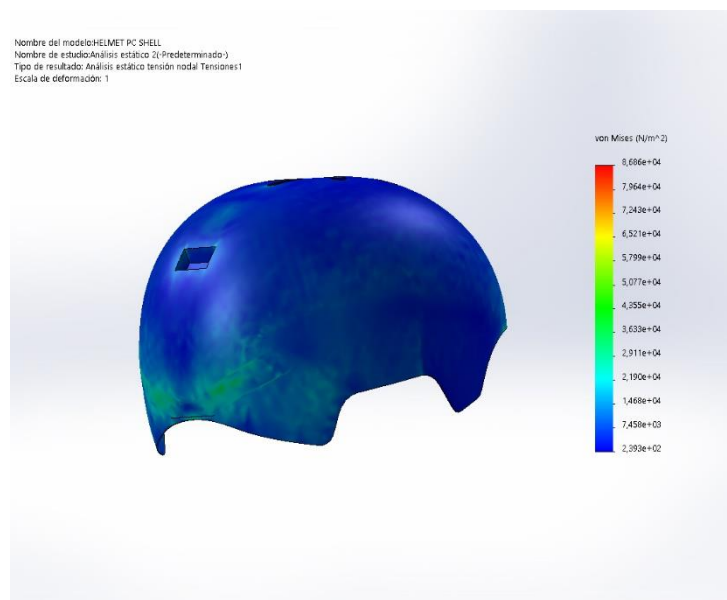

Figure 59: Structural Analysis final graph

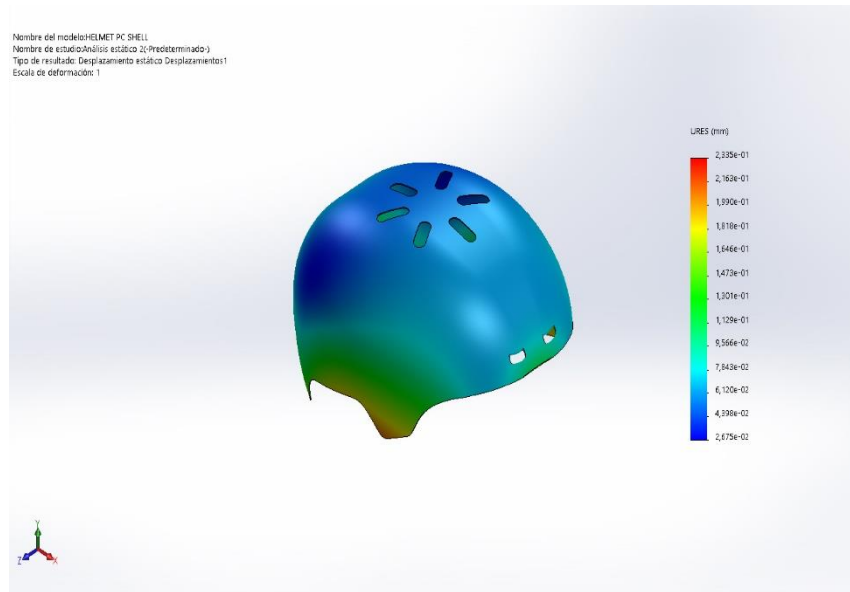

Figure 60: Strain analysis

For the second analysis, a drop simulation has been performed, also using SolidWorks Simulation. In this case, the type of analysis was a drop analysis, using the variables shown in the following list:

- The weight of a 95% man's head, which is equivalent to between 6-7kg (a value of 6.5kg has been set to define an intermediate point) multiplied by gravity (9.81 m/s²).
- The impact zone has been defined as the perimeter around the hole to be assessed.

As in the previous simulation, SolidWorks has produced a document with the complete analysis. This document is presented in full in [ANNEX 3. SOLIDWORKS SIMULATIONS. DROP SIMULATION].

A summary of the document is shown below:

Nombre del modelo: HELMET_PC_SHELL
 Nombre de estudio: Cálculo 3 (-Predeterminado-)
 Tipo de resultado: Desplazamientos 1
 Intervalo: 20 tiempo: 628,298 Microsegundos
 Escala de deformación: 1

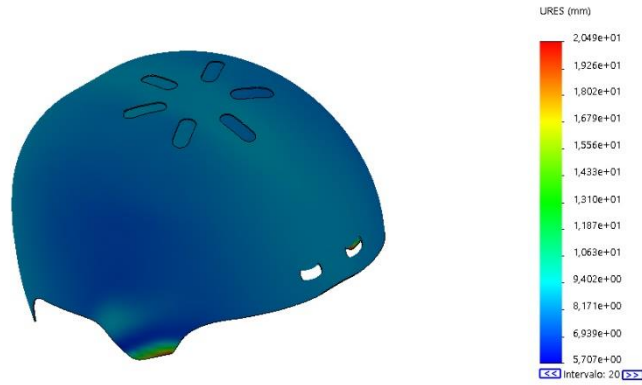

Figure 61: Strain simulation graph for Drop Tests



Material properties

Model Reference	Properties	Components
	<p>Name: ABS PC Model type: Linear Isotropic elastic model Default error criterion: Unknown Tensile limit: 4e+07 N/m² Elastic modulus: 2,41e+09 N/m² Poisson's ratio: 0,3897 Density: 1.070 kg/m³ Shear modulus: 8,622e+08 N/m²</p>	<p>Solid 1(Solid 1)(HELMET ABS/PC SHELL)</p>
Curve data: N/A		

Figure 62: Material properties table for helmet shell

5.4 Technical information

Integrated technology and why's:

- Integrated Speakers^{AK}. Integrated speakers allow users to listen to music or receive audio instructions without needing external devices. This feature enhances the skiing experience by providing entertainment and communication capabilities, fitting seamlessly into the helmet's design.
- LED Lights^{AL}. LED lights improve visibility in low-light conditions, increasing safety for the user. They are integrated into the helmet's design to provide illumination without adding bulk, ensuring both functionality and aesthetic appeal.
- Rechargeable Battery^{AM}. The rechargeable battery powers all electronic components of the helmet, offering convenience and sustainability. This feature eliminates the need for disposable batteries, aligning with eco-friendly practices and ensuring long-term usability.
- PCB (Printed Circuit Board)^{AN}. The PCB is essential for connecting and managing the helmet's electronic components. It ensures reliable performance and efficient power distribution, fitting well within the helmet's compact design.
- Cables^{AO}. Cables are necessary for connecting various electronic components within the helmet. They are designed to be discreet and durable, ensuring that they do not interfere with the helmet's comfort or functionality.
- Cable connectors^{AP}. It is a part that attaches to the end of a cable, allowing it to connect to another cable. It is to promise a secure connection for transferring power.
- Bluetooth Module^{AQ}. The Bluetooth module enables wireless connectivity with other devices, such as smartphones or GPS units. This feature enhances the helmet's versatility and user convenience, allowing for hands-free communication and audio streaming.
- Presence Sensor^{AR}. The presence sensor detects when the helmet is being worn, automatically activating, or deactivating certain features. This smart functionality improves battery life and user convenience, integrating seamlessly into the helmet's design.
- USB-C Input^{AS}. The USB-C input provides a modern and efficient way to charge the helmet's battery and update its firmware. This feature ensures compatibility with current technology standards and enhances the helmet's usability.
- On/Off Button^{AT}. The on/off button allows users to easily control the helmet's electronic features. This simple yet essential component ensures that the helmet's functions can be managed effortlessly, contributing to overall user satisfaction.

Other accessories were evaluated but ultimately excluded due to their high cost and limited accessibility. These accessories, while potentially beneficial, were deemed non-essential compared to the core technologies included. By focusing on the selected features, we ensured that the helmet meets key performance indicators (KPIs) such as safety, comfort, and user satisfaction without exceeding budget constraints.

In conclusion, the chosen technologies for the ski helmet provide a balanced combination of safety, comfort, and modern functionality. By prioritizing these features, we have created a product that meets user needs and market demands effectively. The decision to exclude certain

high-cost accessories ensures that the helmet remains accessible and affordable while still delivering exceptional performance.

5.5 Batch size

Batch size refers to the quantity of units produced in a single production run. It is a critical factor in manufacturing as it influences production efficiency, cost management, and inventory control. An optimal batch size balances production costs with market demand, ensuring profitability and resource optimization³¹.

To determine the optimal batch size for manufacturing ski helmets, several factors must be considered:

- **Market Analysis:** Assess the current market demand for ski helmets and forecast future trends. This involves analyzing sales data, market growth, and consumer preferences³².
- **Cost Analysis:** Evaluate the fixed and variable costs associated with production. Fixed costs include machinery, setup, and tooling, while variable costs cover materials, labor, and overhead³³.
- **Production Capacity:** Consider the manufacturing facility's capacity and efficiency. This includes the availability of resources, production speed, and potential bottlenecks³⁴.
- **Inventory Management:** Analyze the costs of holding inventory versus the benefits of bulk production. This involves understanding storage costs, potential obsolescence, and cash flow implications³⁵.
- **Economies of Scale:** Larger batch sizes can reduce the per-unit cost due to economies of scale. However, this must be balanced against the risk of overproduction and excess inventory³⁶.

After a thorough analysis of the market, current demand for similar products, and estimated future demand and distribution, we have decided that the batch size for our new ski helmet design will be 20,000 units. This decision is based on the following considerations:

- **Market Demand:** The analysis indicates a steady demand for ski helmets, with potential growth in the upcoming seasons.
- **Cost Efficiency:** Producing 20,000 units allows us to achieve economies of scale, reducing the per-unit cost and optimizing resource utilization.
- **Production Optimization:** This batch size aligns with our production capacity, ensuring efficient use of machinery and labor without causing bottlenecks.
- **Inventory Control:** A batch size of 20,000 units strikes a balance between meeting market demand and minimizing inventory holding costs.

In conclusion, manufacturing a batch of 20,000 ski helmets is deemed optimal for ensuring profitability and meeting market needs effectively. This decision allows us to leverage economies of scale, optimize production processes, and maintain efficient inventory management.

5.6 Bill Of Materials

BILL OF MATERIALS												
Product	Group	Part	Description	Drawing	PRODUCT					PRICE		
					make / buy	link	quantity	material	weight (g)	total weight (g)	price (€)	total price (€)
Ski helmet [1000]	Helmet structure [1010]	1011	Helmet shell	1011	make	-	1	ABS / PC	200	200	5	5
		1012	ABS glue		buy		1	-	2	2	0,5	0,5
		1013	Protective foam	1012	make	-	1	EPP	50	50	4	4
		1014	MIPS	1013	make	-	1	PC	100	100	2	2
		1015	MIPS foam	1014	make	-	1	EPS	20	20	1	1
	LED box [1020]	1021	LED box	1021	make	-	1	ABS / PC	20	20	1	1
		1022	LED light		buy	link	1	-	13	13	1	1
		1023	PCB		buy	link	1	-	5	5	0,45	0,45
		1024	USB-C input		buy	link	1	-	2	2	0,2	0,2
		1025	Battery		buy	link	1	-	84	84	1,5	1,5
		1026	Impact sensor		buy	link	1	-	2	2	1,95	1,95
		1027	Cable		buy	link	1	-	5	5	1,5	1,5
		1028	Cable connector		buy	link	2	-	1	2	0,15	0,3
	1029	Rubber gasket		buy	link	1	-	5	5	1	1	
	Earpads [1030]	1031	Earpad	1031	make	-	2	EPS	50	100	5	10
1032		Bluetooth sensor		buy	link	1	-	2	2	0,25	0,25	
1033		Microphone		buy	link	1	-	1	1	0,2	0,2	
1034		Speaker		buy	link	1	-	2	2	1,15	1,15	
1035		On/ off button		buy	link	1	-	1	1	0,25	0,25	
1036		Chin straps		buy	link	2	-	10	20	1,25	2,5	
1037		Closing click system		buy	link	1	-	10	10	2	2	
total									646	646	total	37,75

Figure 63: BOM

[All links of products included in BOM are attached in bibliography of this document, and datasheets on ANNEX 5. BILLOF MATERIALS BUY COMPONENT DATASHEETS].

In summary, the Bill of Materials shows a well-organized and detailed structure of all the components required for the manufacturing of the technological helmet, with a total cost of 37.75€. This information is crucial for production planning and management, ensuring that all necessary elements are available and that costs remain within the projected budget.

Apart from this, in the last line of the BOM, there is a total summary of how much the product will weight and cost.

- Weight is on top of the kpi: $500 < 645,5 < 700$ g. But still in the defined parameters.
- Price is under expected. Here manufacturing costs have been taken into account, but not the desired benefits.

5.7 Technical drawings

In this section, we present the exploded views of the designed components and the complete product, correlating with the previously shown Bill of Materials (BOM). These detailed illustrations provide a comprehensive visualization of the assembly and individual parts. For further reference, the individual component drawings have been included in [ANNEX 5. TECHNICAL DRAWINGS].

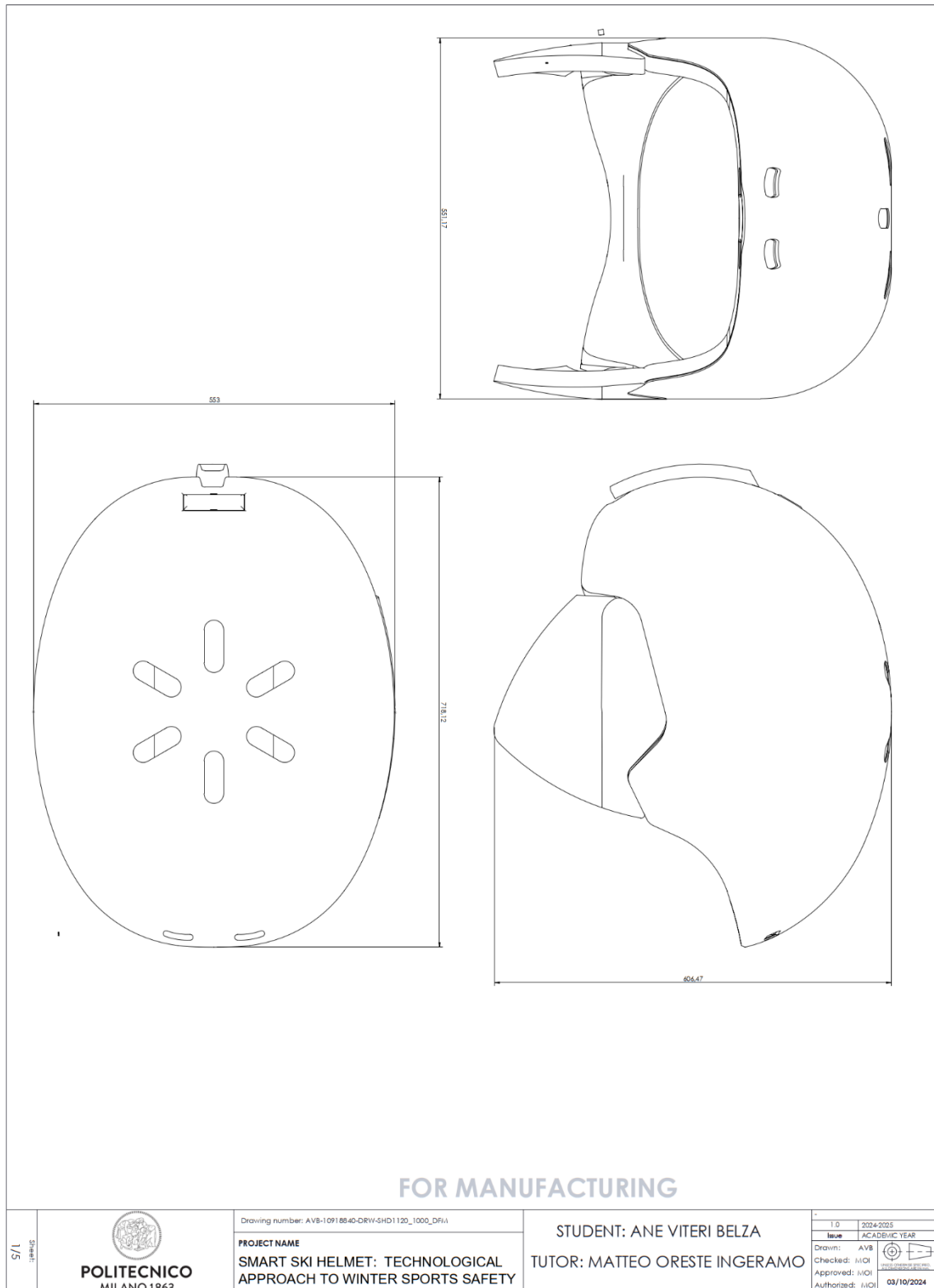

Figure 64: Total Assembly Technical Drawing_Main dimensions

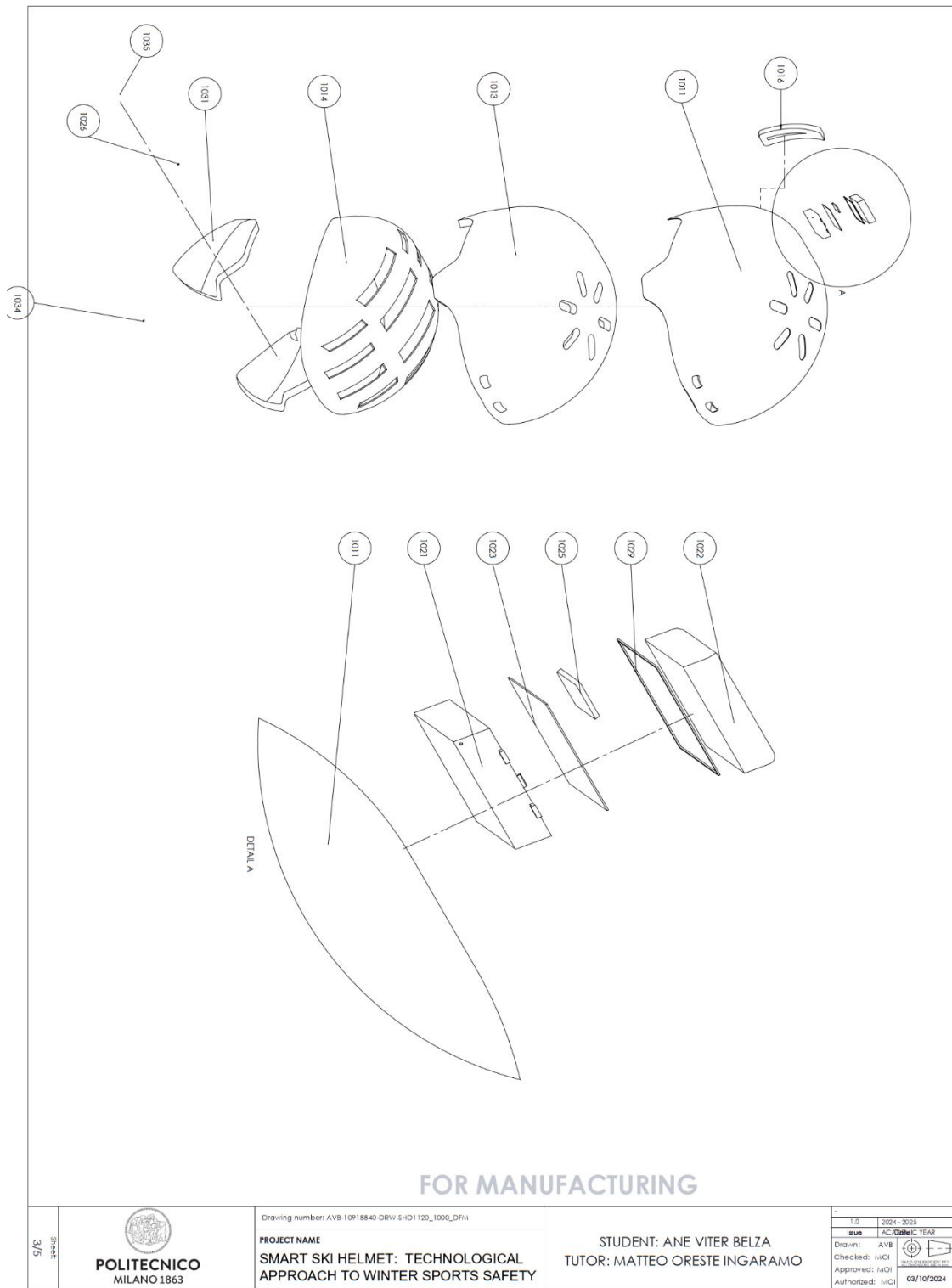

Figure 65: Total Assembly Technical Drawing_Main exploded view

ELEMENT NUM.	DESCRIPTION	MAKE OR BUY	DRAWING NAME	MATERIAL	QTY
1011	Helmet ABS/PC shell	MAKE	AVB-10918840-DRW-SHD1120_1011	ABS / PC	1
1013	Foam shell-MIPS	MAKE	AVB-10918840-DRW-SHD1120_1013	EPPS	1
1014	MIPS	MAKE	AVB-10918840-DRW-SHD1120_1014	PC	1
1016	Goggles arrangement	BUY	.	-	1
1021	LED light and electronics case	MAKE	AVB-10918840-DRW-SHD1120_1021	ABS / PC	1
1022	LED light	BUY	-	-	1
1023	PCB	BUY	-	-	1
1024	USB-C INPUT	BUY	.	-	1
1025	Rechargeable Battery	BUY	.	-	1
1026	IMPACT SENSOR	BUY	.	-	1
1028	Cable connector	BUY	.	-	2
1029	Rubber seal	BUY	-	-	1
1031	Earmuffs	MAKE	AVB-10918840-DRW-SHD1120_1031	PU	1
1033	MICROPHONE	BUY	.	-	1
1034	SPEAKER	BUY	.	-	1
1035	ON-OFF BUTTON	BUY	.	-	1

FOR MANUFACTURING

 POLITECNICO MILANO 1863	Drawing number: AVB-10918840-DRW-SHD1120_1000_Df.v1	STUDENT: ANE VITERI BELZA TUTOR: MATTEO ORESTE INGARAMO	1.0 2024-2025
	PROJECT NAME SMART SKI HELMET: TECHNOLOGICAL APPROACH TO WINTER SPORTS SAFETY		Drawn: AVB Checked: MCI Approved: MCI Authorized: MCI

Figure 66: Total Assembly Technical Drawing_BOM

5.8 Manufacturing processes

This section evaluates the manufacturing processes for the two parts of the helmet shell, which will be made from the same material, as well as the manufacturing process for the interior of the helmet.

In the previous section, a conclusion was made about which materials are most appropriate for both parts of the product, but for economic reasons that will be considered in the future, the manufacturing process for the helmet shell using ABS will also be taken into account.

Manufacturing Process of Outer Shell in ABS/PC³⁷:

1. Mold Fabrication:

1.1 Mold Fabrication: A mold is crafted from steel or aluminum according to the CAD design specifications. The mold has the inverse shape of the helmet shell.

1.2 Mold Preheating: Prior to injection, the mold is preheated to ensure that the ABS/PC mixture flows correctly and fills all the mold details.³⁸

2. Injection Molding Process:

2.1 ABS/PC Melting: ABS and PC granules are fed into an injection molding machine, where they are heated until they reach their melting point, becoming a viscous and malleable material.

2.2 Injection: The melted ABS/PC mixture is injected at high pressure into the preheated mold. The pressure ensures that the material completely fills the mold and takes on the desired shape.

2.3 Cooling: Once the mold is filled, it is left to cool. During cooling, the ABS/PC mixture solidifies and takes the shape of the helmet shell.

3. Demolding:

3.1 Mold Opening: After the ABS/PC mixture has cooled and hardened, the mold is opened, and the helmet shell is removed. Initial Inspection: The shell is visually inspected for defects such as bubbles, burrs, or poorly formed areas.

4. Finishing:

4.1 Deburring: Burrs or excess material around the edges of the shell are removed.

4.2 Polishing and Sanding: The surface of the shell can be sanded and polished to achieve a smooth and uniform finish.

4.3 Coating Application: If necessary, protective or decorative coatings such as paints or varnishes are applied to enhance aesthetics and UV resistance.

5. Testing and Verification³⁹:

5.1 Quality Testing: The shell undergoes quality tests to ensure it meets safety and performance standards, such as impact resistance and heat resistance tests.

5.2 Final Fit: It is checked that the shell fits perfectly with the other components of the helmet, such as the inner lining and straps.

B. Manufacturing process of inner protection foam in EPP:⁴⁰

1. Mold Preparation:

1.1 Mold Fabrication: A mold is made from steel or aluminum based on the CAD design of the protector. The mold must have cavities with the inverse shape of the interior protectors.

1.2 Mold Preheating: Before molding, the mold is preheated to ensure that the EPP beads expand evenly and fill all the cavities of the mold.

2. EPP Compression Molding Process:

⁴¹

2.1 EPP Pre-expansion: The EPP beads undergo a pre-expansion process using steam. This process expands the beads to a specific size before they are introduced into the mold.

2.2 Mold Loading: The pre-expanded beads are introduced into the mold.

2.3 Compression Molding: Once the mold is loaded, steam and pressure are applied to expand and fuse the EPP beads together, forming a solid structure that takes the shape of the mold.

2.4 Cooling: After molding, the mold is cooled to solidify the structure and ensure that the EPP retains its shape.

3. Demolding:

3.1 Mold Opening: After the material has cooled and solidified, the mold is opened, and the interior protectors are removed.

3.2 Initial Inspection: The protectors are inspected for any defects, such as bubbles, unfused areas, or deformations.

4. Finishing:

4.1 Cutting and Trimming: If necessary, cutting or trimming is done to remove any excess material and ensure that the protectors fit perfectly inside the helmet.

4.2 Polishing: In some cases, the surface of the protectors may be lightly polished to smooth the edges and improve comfort.

5. Testing and Verification:

5.1 Quality Testing: The protectors undergo quality tests to ensure they meet safety standards, including impact absorption and durability.

5.2 Fit Testing: It is verified that the protectors fit correctly inside the helmet shell and provide the necessary comfort and protection.

This section evaluates the manufacturing processes for the helmet shell and interior. The helmet shell can be made from Polycarbonate (PC) or Acrylonitrile Butadiene Styrene (ABS), while the interior uses Expanded Polypropylene (EPP).

The process for the ABS shell involves creating steel or aluminum molds, melting and injecting ABS granules, and then cooling and demolding. Finishing steps include deburring, polishing, and applying coatings, followed by quality testing. The cost of manufacturing an **ABS** helmet shell is generally lower, typically around **€3.00-4.50 per unit**.

For the **ABS** shell, the process is similar, involving mold preparation, injection molding, cooling, and demolding, with finishing steps like deburring and coating. Rigorous quality tests ensure the shell meets safety standards. ABS is cheaper than polycarbonate, with manufacturing costs around **€2.70-4.50 per unit**. The EPP interior involves pre-expanding beads, loading them into molds, and fusing them using steam and pressure. After cooling and demolding, the protectors are cut, trimmed, and polished, with quality tests ensuring impact absorption and durability. **EPP costs around €3.60-5.40 per unit**.

Combining the costs of the shell and interior, the total manufacturing cost for a **helmet ranges from €10.80 to €16.20 per unit**.

5.9 Assembly process

The assembly process of a polycarbonate ski helmet shell involves several critical steps⁴² to ensure the helmet is both safe and comfortable for the user. This process includes: integrating a Multi-directional Impact Protection System (MIPS) shell, attaching Expanded Polypropylene (EPP) foam, incorporating fabric ear pads with embedded technology, and securing the chin straps.⁴³

Step 1: Preparation of components

Before assembly begins, all components must be prepared:

- **ABS Shell:** The outer shell is cleaned and inspected for any defects.
- **MIPS Shell:** The MIPS shell is prepared and checked for proper fit within the polycarbonate shell.
- **EPP Foam:** The EPP foam pieces are cut and shaped to fit the interior of the helmet.
- **Ear Pads:** Fabric ear pads with integrated technology (e.g., speakers, microphones) are prepared.
- **Chin Straps:** The straps are cut to the appropriate length and fitted with buckles.
- **LED Light Housing:** The housing for the LED light at the crown is prepared and inspected.
- **LED Insulation Gasket:** The gasket for insulating the LED light is prepared.
- **PCB:** The printed circuit board (PCB) is prepared and tested for functionality.
- **Portable Battery:** The portable battery is charged and checked for proper operation.

- **Electronic Components:** All electronic components to be housed in the LED light box are prepared and tested.

Step 2: Attaching the MIPS Shell ⁴⁴

The MIPS shell is carefully positioned inside the polycarbonate shell. It is secured using adhesive or mechanical fasteners, ensuring it is firmly attached and can move slightly to provide the intended rotational motion during an impact.

Step 3: Inserting the EPP Foam

EPP foam pieces are inserted into the helmet, adhering them to the interior surface of the MIPS shell. A strong adhesive is used to ensure the foam remains in place, providing cushioning and impact absorption. The foam is pressed firmly to eliminate any gaps and ensure a snug fit.

Step 4: Installing the LED light housing and electronics

The LED light housing is positioned at the crown of the helmet. The insulation gasket is placed around the LED light to ensure proper insulation. The PCB, portable battery, and other electronic components are installed within the LED light box. All connections are checked to ensure they are secure and functional.

Step 5: Attaching the Ear Pads

The fabric ear pads are attached to the sides of the helmet. They are secured using either adhesive or mechanical fasteners, ensuring they are firmly in place. The embedded technology within the ear pads is connected to the helmet's internal wiring system, if applicable.

Step 6: Securing the chin straps ⁴⁵

The chin straps are attached to the helmet at designated anchor points. They are threaded through the helmet's structure and secured with strong stitching or rivets. The straps are adjusted to ensure they can be comfortably fastened under the user's chin, providing a secure fit.

Step 7: Final Inspection and testing ⁴⁶

Once all components are assembled, the helmet undergoes a final inspection. This includes checking the integrity of all attachments, ensuring the MIPS system functions correctly, and verifying the comfort and fit of the ear pads and chin straps. The helmet is also subjected to safety tests to ensure it meets all relevant standards and regulations.

By following these steps, the polycarbonate ski helmet is assembled to provide maximum safety, comfort, and functionality for the user, including the integration of advanced electronic components.

5.10 Final product presentation

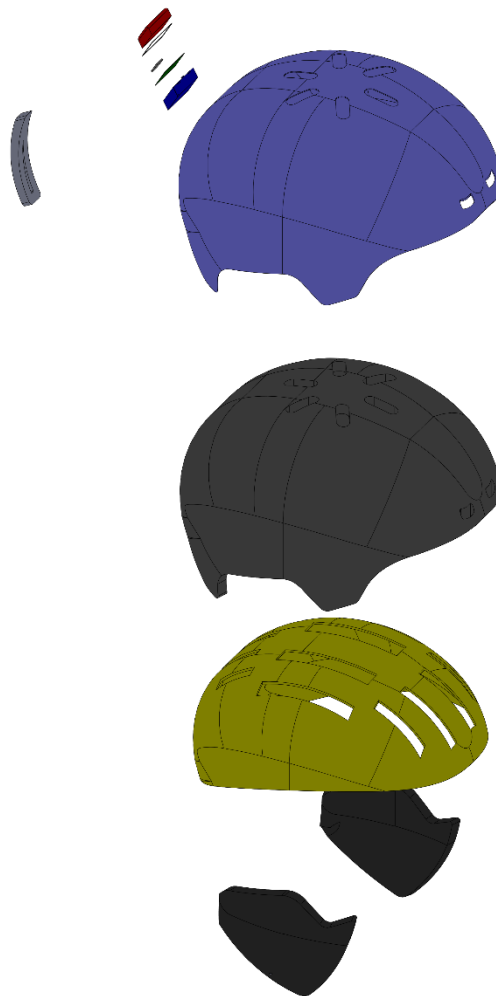

Figure 67: Product isometric exploded view render

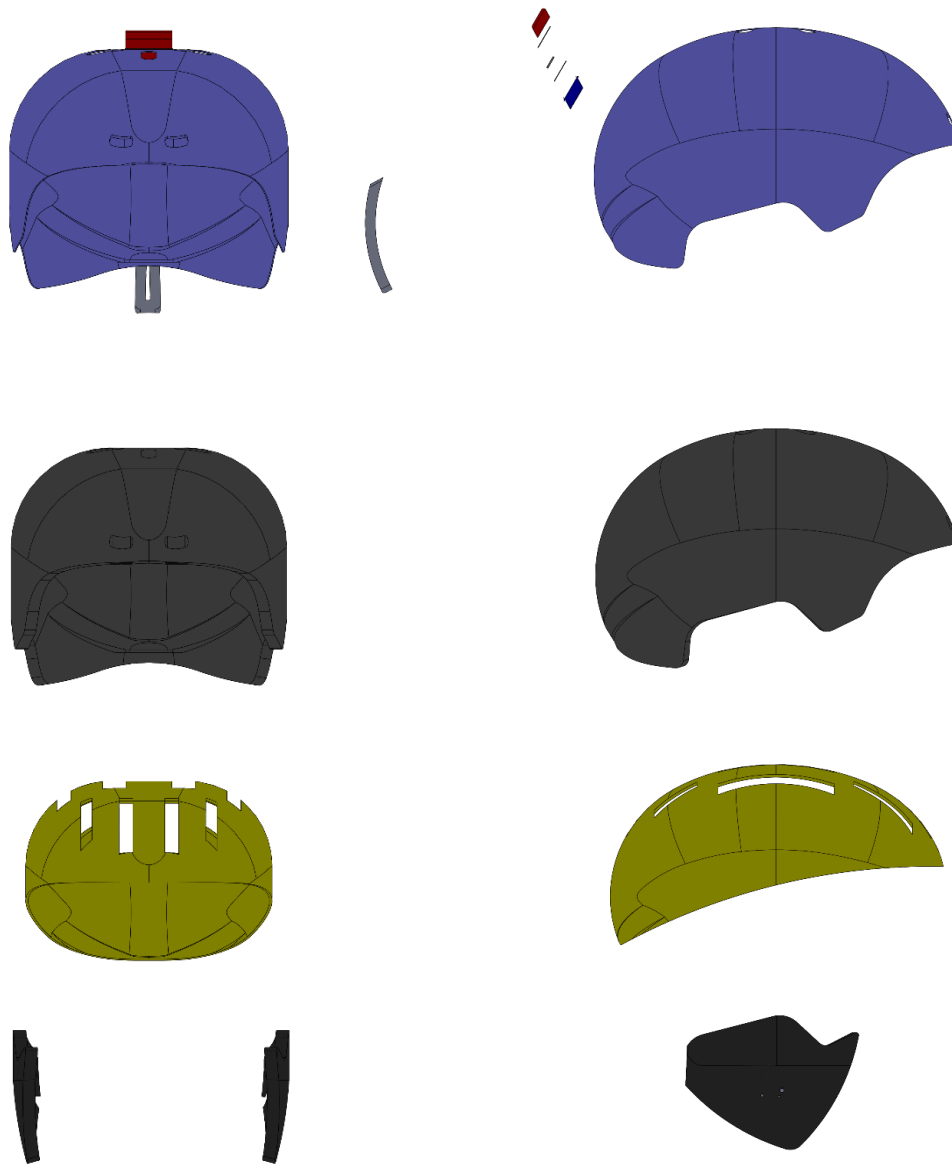

Figure 68: Exploded views render



Figure 69: Back view of product

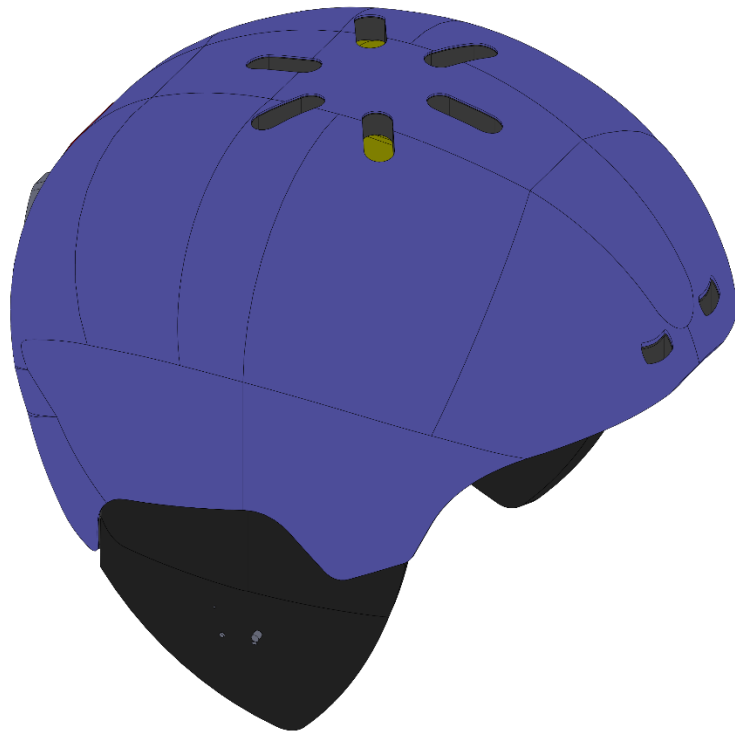

Figure 70: Helmet render

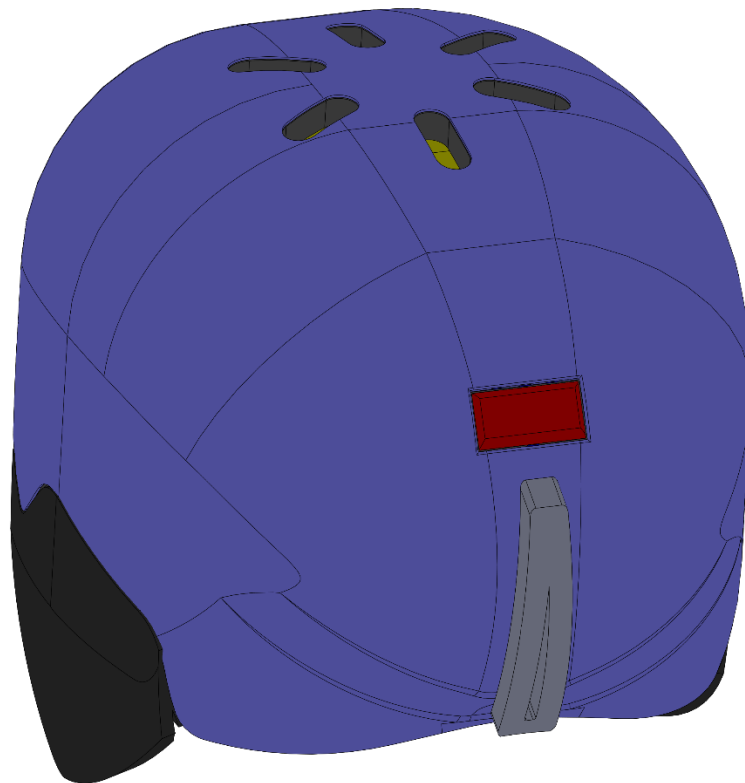

Figure 71: Helmet render

5.10.1 Appearance justification

Once the helmet has been made as the main shape, it is interesting to enter the world of graphic design/the exterior aspect of it.

The helmet has maintained the general shape that is generally expected of them: round and with tangents, mostly adapted to the shape of the human head. In this case, the parameters have been conditioned by the general shape of helmets, especially inspired by the rounded ones from POC.

Some helmets have integrated ear pads within the same shell shape, and others are "separate" pads that attach to the edge of the helmet. In this case, as has been obvious from the beginning, since a lot of electronic elements were to be introduced into the ear pad, a design of visible pads was chosen, so that the ears remain warm but with flexibility.

As for customization, it is clear that inserting this last LED light, with its corresponding casing on the top of the head, has marked a great differentiation from the rest of the helmets available on the market.

To continue, focusing on graphic design, I have decided to go for bright colors, making the helmet a single, solid color but very visible. In my case, since my favorite color is blue, I have chosen it to show the helmet, as you have seen. But, in addition to simple and single-color designs, I have thought that for future versions, a helmet design with a light blue background and drawings of skiers on it could be applied, to give it a distinctive touch.

6. PROJECT MONITORING AND FINANCES

6.1 Budget

This section presents a comprehensive budget analysis for the production and market launch of the technologically advanced ski helmet. It includes detailed cost estimates for labor, manufacturing, and initial setup, as well as projections for bringing the product to market. By examining these financial aspects, we aim to provide a clear understanding of the economic feasibility and potential profitability of the ski helmet, ensuring that all necessary resources are accounted for to achieve a successful product launch.

6.1.1 Design budget

This is the budget for the product designer:

DESIGN BUDGET					
Issuing entity		Issuing date		03/07/2024	
Recipient entity		Charge period		01/02/2024 - 30/06/2024	
PERSONNEL					
Product / Item to be payed	Price		Hours		Total
Project manager	20	€ / h	40	h	800
Senior designer	18	€ / h	120	h	2160
Junior designer	10	€ / h	150	h	1500
Prototype laboratory worker	10	€ / h	50	h	500
Electrical Engineer	15	€ / h	15	h	225
Materials Engineer	15	€ / h	30	h	450
					€ 5635
LICENSES					
Product / Item to be payed	Price		Hours Used		Total
SolidWorks	1000	€ / license	100	h	1000
Rhinoceros 8	1000	€ / license	25	h	250
Microsoft Office Package	1000	€ / license	150	h	1500
					€ 2750
RESOURCES / MATERIALS					
Product / Item to be payed	Price		Hours used		Total
Raw material	1	€/h	3	h	3
3D printer	1	€ / h	20	h	20
Sewing machine	1,5	€ / h	10	h	15
IT Systems (projector, speaker...)	5	€ / h	15	h	75
Office material	5	€ / h	275	h	1375
					€ 1485
Total to be payed					€ 9870

Figure 72: Design budget

The design budget is an estimate of the cost of the design consultant's work, software used for 3D modelling and testing prototypes before the final design sale is marketed. This adds up to €5,635 in employee hours, another €3000 for the 3D software multiplied by their hours of use, and the material for the prototypes which is another €1500. In total the design budget comes to 9870€.

6.1.2 Material procurement and manufacturing budget

This is the budget for the manufacturing phase:

MATERIAL PROCUREMENT AND MANUFACTURING BUDGET					
Issuing entity		Issuing date		03/07/2024	
Recipient entity		Charge period		01/04/2024 - 10/06/2024	
MATERIAL PROCUREMENT					
Product to be payed	Price		Kg		Total
ABS / PC	0,5	€ / kg	10000	h	5000
EPPS	0,25	€ / kg	7000	h	1750
Glue	0,15	€ / lot	10	lot	1,5
					€ 6751,5
MANUFACTURING					
Process	Price		Hours Used		Total
Moulds	100	€	500	h	500
Injection moulding	100	€	500	h	500
Mechanized parts	50	€	200	h	10000
					€ 11000
RESOURCES / MATERIALS					
Product to be payed	Price		Hours used		Total
COTS	5	€	100	h	500
Milling machine	1	€	700	h	700
injection moulding	2	€	700	h	1400
Polimeric sanding	0,5	€	700	h	350
Workers	15	€	800	h	12000
					€ 14450
Total to be payed					€ 32201,5

Figure 73: Manufacturing budget

The budget for material procurement and production is divided into 3 sections: material procurement = 6751,5€, production 11000€ and assembly and employee hours = 14450€. The total sum is € 32201.5.

This leaves the price of design and manufacture of 20.000 parts at €4271,5. This means there is 2,11e per helmet. Taking this price, the electronic part price (shown in the BOM) and the manufacturing material cost mentioned in previous sections, the final price of the helmet could be of:

$37.75 + 2.11 = 39.86$ €. If we want a benefit of the 100% = $39.86 * 2 = 79.72€$ this is still in the kpi slot with a big possible improvement margin.

6.3 Project Gantt

This Gantt has been designed following the simulation of the design and post-production phase of the product in an average period of 6 months, being aware that there may be delays, especially in material procurement and product manufacturing.

Due to space issues along the document, the Gantt chart is presented in the [ANNEX 6. PROJECT GANTT] part.

Here is a scheme on how the phases are divided:

PROJECT PHASES	
MILESTONE	ACTIVITY
Meeting with clients	Project launch / Contract signature
BRIEFING	
	User definition
	Market and competitor analysis
	Scientific and technical research
CONCEPT	
	Concept definition
	Engineering charts
	Project presentation document
Meeting with clients	Concept closing
DESIGN	
	Concept specific definition
	3D model development
	Buy components list
	Suppliers research
	Electric component trial
	Fist mock-ups
Meeting with clients	Design presentation
FINAL PRODUCT	
	Final 3D model
	Drawings
	Electronic component development
	Material selection report
	Manufacturing processes report
	Assembly process report
	Budget
Meeting with clients	Product and budget presentation
MARKET LAUNCH	
	Previous product presentation
	Launch into the market
	User trial and backup (for incoming upgrades)
Meeting with clients	Project closing and backup report presentation

Figure 74: Project Gantt Phases

7. CONCLUSION

In this master's thesis, I worked on creating a smart ski helmet that combines advanced technology with innovative design. I started by doing a detailed market analysis to understand existing products, user needs, and popular colors. This analysis helped shape the design process.

During the design phase, I had many brainstorming sessions to refine ideas. These sessions led to the creation of a 3D model that includes the latest technology for ski helmets. The model focuses on combining functionality and user safety. Choosing the right materials was crucial to balance durability, comfort, and cost. The manufacturing and assembly processes were carefully planned to ensure efficiency and high quality.

Throughout the project, I learned a lot about using technology in extreme conditions. The smart ski helmet shows how advanced technology can improve user experience and safety in risky environments. The project also highlighted the importance of working with experts from different fields, like engineering, design, and finance. This teamwork was essential to overcome the challenges we faced.

I created several detailed budgets for different parts of the project, including design, materials, manufacturing, and the potential market price. The financial analysis showed that bringing this innovative ski helmet to market is feasible and competitive. This analysis was important to ensure the project stayed financially viable and met market expectations.

The project also explored the broader impact of integrating advanced technology into everyday products. The smart ski helmet sets a new standard for safety and performance in the industry. This project has been a valuable learning experience, deepening my understanding of technology's potential in challenging scenarios. It also emphasized the importance of user-centered design to exceed user expectations.

In conclusion, this master's thesis demonstrates how engineering and design principles can create a product that meets and exceeds market demands and user expectations. The smart ski helmet represents a significant advancement in the industry, setting a new benchmark for safety and performance. This project has been an invaluable learning experience, providing insights into the complexities of product development and the importance of interdisciplinary collaboration.

8. REFERENCES

8.1 General information

- [1] [Skiing in recent European history: The rise of skiing...](#)
- [2] [5 stages in the Design Thinking Methodology - Article](#)
- [3] [Article about the POC OBEX Ski Helmets](#)
- [4] [How to choose a ski helmet - Luderna](#)
- [5] [Snowboard and Ski helmets - Amazon](#)
- [6] [Retrospec Zephyr Snowboard Helmet for adults - Amazon](#)
- [7] [EPS in-mold technology - Aurora Helmets](#)
- [8] [In-mold ski helmets - Helmetsrus](#)
- [9] [best Ski Helmets - Gearjunkie](#)
- [10] [Best ski helmets - Switch backtravel](#)
- [11] [MIPS protection - oficial web page](#)
- [12] [Helmet technology - MIPS protection](#)
- [13] [Koroyd technology - Smith-Quantum](#)
- [14] [Internet of Things - IBM](#)
- [15] [Internet of Things - Wikipedia](#)
- [16] [Internet of Things - Coursera Articles](#)
- [17] [Best IoT industry 4.0 Implementations - IoT now](#)
- [18] [Wristwatches -AE](#)
- [19] [Human Ergonomics well being overall-system performance](#)
- [20] [Ergonomic Principles of Frederick Winslow Taylor in 19th and 20th centuries](#)
- [21] ["The Design of Everyday Things" by Don Norman](#)
- [22] [Contact and tactile response - CadCrowd](#)
- [23] [Intuitive use](#)
- [24] [Human head measurements - S1 helmets](#)
- [25] [How colors affect in our emotions - Universidad ISEP](#)
- [26] [Color Psiclology and the meaning of the colors and their applications - Online Psychology](#)
- [27] [Material selection for a ski helmet - reanson](#)
- [28] [ABS injection molding processes - Sungplastic](#)
- [29] [How helmets are made - Cortocircuito](#)
- [30] [Three materials used in helmets - Helmet supplier](#)
- [31] [Batch productions - Learn lean sigma](#)
- [32] [What does batch size mean - Biz manualz](#)
- [33] [Calculating productio batches - Demand driven tech](#)
- [34] [Calculate optimal batch size - Stackoverflow](#)
- [35] [Perfect size for a production line business decision - Kaiser tech consulting](#)
- [36] [How to determine optimum batch size - Themba institute](#)
- [37] [EPP foam - manufacturing process - EPSOLE](#)
- [38] [EPP foam moulding manufacturing - EPP forum](#)
- [39] [Mechanisms for ski equipment - Mechanics of Sport](#)
- [40] [Ski helmet manufacturing processes - OSUM](#)
- [41] [What is MIPS - Skimag](#)
- [42] [How should ski helmet fit - Headsontbounce](#)
- [43] [How Long ski helmets last - Haedsontbounce](#)

[44] [Ski standards and certification explained -Team Wendy](#)

8.2 Product links

- [A] [Smith Optics - Smith Vantage MIPS](#)
- [B] [POC - POC Obex BC Spin](#)
- [C] [Giro - Giro Range MIPS](#)
- [D] [Atomic - Atomic Revent+ Amid](#)
- [E] [Salomon - Salomon MTN Lab](#)
- [F] [Sweet Protection - Sweet Protection Grinnir II TE](#)
- [G] [Scott - Scott Symbol 2 Plus D](#)
- [H] [Bern - Bern Watts EPS](#)
- [I] [Bollé - Bollé B-Style](#)
- [J] [K2 - K2 Diversion](#)
- [K] [Uvex - Uvex Jakk+ IAS](#)
- [L] [Four Amid Pro](#)
- [M] [Savor GT AMID Ctd](#)
- [N] [Pioneer LT Pro](#)
- [O] [POC Fornix Helmet](#)
- [P] [POC Obex MIPS Helmet](#)
- [Q] [POC OBEX BC MIPS](#)
- [R] [Compact pro ski helmet](#)
- [S] [REV ski helmet](#)
- [T] [SP-4.1](#)
- [U] [OAKLEY MOD5 - MIPS](#)
- [V] [MOD1 PRO SL](#)
- [W] [C20 - Urban Helmet](#)
- [X] [RYFT MIPS Bollé](#)
- [Y] [LED LIGHTS](#)
- [Z] [BLUETOOTH](#)
- [AA] [MICROPHONE and SPEAKER](#)
- [AB] [VELOCITY SENSOR](#)
- [AC] [TEMPERATURE SENSOR](#)
- [AD] [PRESENCE SENSOR](#)
- [AE] [GPS](#)
- [AF] [CAMERA](#)
- [AG] [POC Aid headphones](#)
- [AH] [RECCO](#)
- [AI] [Adjustable Giro Loc Roc DH System](#)
- [AJ] [MIP impact security system](#)
- [AK] [Integrated Speakers](#)
- [AL] [LED lights](#)
- [AM] [Rechargeable battery](#)
- [AN] [PCB](#)
- [AO] [Cables](#)
- [AP] [Cable connectors](#)
- [AQ] [Bluetooth module](#)
- [AR] [Presence sensor](#)

[AS] [USB-C input](#)

[AT] [On/ Off button](#)

9. ANNEXES

In this section, we present the comprehensive manufacturing blueprints of the final product, alongside various documents referenced throughout the project. These annexes provide an in-depth view of the technical specifications, detailed schematics, and procedural guidelines that underpin the development and realization of the intelligent ski helmet. By including these extensive documents, we aim to offer a thorough understanding of the intricate processes and meticulous planning involved in bringing this innovative product to fruition.

ANNEX 1. DOC. UNE-EN 1077

COPYRIGHT NOTICE

This document is the copyright of the Publisher. All rights reserved.

The contract allowing you to use this document contains the following terms of use which must be followed:-

(a) You may view and print a single copy of a document contained in the Subscription for reference purposes only and only for internal purposes within the site on which such copies are made, providing such copies are dated and destroyed after the reference usage, typically no more than 60 working days after use, subject to the exception described in clause (b) below. Such copies may not be filed to form part of any hard copy reference collection.

(b) Where you have a specification or tender requirement to reproduce a document or portions of a document as part of its documentation for external submission in response to a tender, the necessary pages of the document, including the whole document if required, may be reproduced and submitted provided a copyright notice is included. You shall notify Intertek Inform of any such use. For internal and archival purposes only, a paper copy may be attached to your documentation and shall be considered a permanent part of that documentation.

(c) Under no circumstances are you permitted to reproduce all or part of any document for external use or for use in any other site or group of sites, except as set forth in (b) above.

(d) You may not remove any proprietary markings or electronic watermarks, including any copyrights and trademarks.

(e) You may copy a maximum of 25% of the content of a document within the Subscription and paste it to another document for internal use. The copied content in the new document must contain a copyright notice "Copyright [name of publisher] Date where date is the date of copyrighted material. Such content is licensed for use only for the duration of the relevant Subscription.

(f) For ISO standards, the material is reproduced from ISO publications under International Organization for Standardization (ISO) Copyright License number INTERTEK INFORM/MCEA/2008. Not for resale. No part of these ISO publications may be reproduced in any form, electronic retrieval system or otherwise, except as allowed under the copyright law in the country of use, or with the prior written consent of ISO (Case postale 56, 1211 Geneva 20, Switzerland, email: copyright@iso.org) or ISO's Members.



In USA and Canada Contact:

Intertek Inform, 545 E Algonquin Rd, Arlington Heights, IL 60005, USA

☎ +1 416 401 8730 Email: uspubsales@intertekinform.com Web: i2.saiglobal.com

In Europe Contact:

Intertek Inform, 12 Davy Avenue, Knowlhill, Milton Keynes, MK5 8NL, UK

☎ : +44 (0)1344 636400 Email: standards@intertekinform.com Web: i2.saiglobal.com

In Asia/Pacific Contact:

Intertek Inform, Level 7, 45 Clarence Street, Sydney NSW 2000, Australia

☎ : +61 2 8206 6060 Email: sales@intertekinform.com Web: i2.saiglobal.com

Helmets for alpine skiers and snowboarders

This standard has been prepared by the Technical Committee CTN 147 *Sports, playground and other recreational* the Secretariat of which is held by IBV.

UNE-EN 1077

Helmets for alpine skiers and snowboarders

Cascos para esquiadores alpinos y de "snowboards"

Casques pour skieurs de ski alpin et de surf des neiges

This standard is the official English version of EN 1077:2007.

This standard was published as UNE-EN 1077:2008, which is the definitive Spanish version.

The remarks to this document must be sent to:

Asociación Española de Normalización

Génova, 6
28004 MADRID-España
Tel.: 915 294 900
info@une.org
www.une.org

© UNE 2020

Reproduction is prohibited without the express consent of UNE.
All intellectual property rights relating to this standard are owned by UNE.

EUROPEAN STANDARD

EN 1077

NORME EUROPÉENNE

EUROPÄISCHE NORM

August 2007

ICS 13.340.20

Supersedes EN 1077:1996

English Version

Helmets for alpine skiers and snowboarders

Casques pour skieurs de ski alpin et de surf nes neiges

Helme für alpine Skiläufer und für Snowboarder

This European Standard was approved by CEN on 17 February 2007.

CEN members are bound to comply with the CEN/CENELEC Internal Regulations which stipulate the conditions for giving this European Standard the status of a national standard without any alteration. Up-to-date lists and bibliographical references concerning such national standards may be obtained on application to the CEN Management Centre or to any CEN member.

This European Standard exists in three official versions (English, French, German). A version in any other language made by translation under the responsibility of a CEN member into its own language and notified to the CEN Management Centre has the same status as the official versions.

CEN members are the national standards bodies of Austria, Belgium, Bulgaria, Cyprus, Czech Republic, Denmark, Estonia, Finland, France, Germany, Greece, Hungary, Iceland, Ireland, Italy, Latvia, Lithuania, Luxembourg, Malta, Netherlands, Norway, Poland, Portugal, Romania, Slovakia, Slovenia, Spain, Sweden, Switzerland and United Kingdom.



EUROPEAN COMMITTEE FOR STANDARDIZATION
COMITÉ EUROPÉEN DE NORMALISATION
EUROPÄISCHES KOMITEE FÜR NORMUNG

Management Centre: rue de Stassart, 36 B-1050 Brussels

Contents

Page

Foreword.....	4
Introduction	5
1 Scope	6
2 Normative references	6
3 Terms and definitions	6
4 Requirements	7
4.1 Materials	7
4.2 Construction.....	8
4.2.1 General.....	8
4.2.2 Retention system	8
4.3 Field of vision.....	9
4.4 Extent of coverage.....	9
4.4.1 Class A.....	9
4.4.2 Class B.....	9
4.5 Shock absorbing capacity	11
4.6 Resistance to penetration.....	11
4.7 Retention system performance	11
4.7.1 Strength	11
4.7.2 Effectiveness.....	11
4.8 Durability	11
5 Testing	11
5.1 Sampling.....	11
5.2 Inspection and determination of mass	12
5.3 Conditioning.....	12
5.3.1 Room conditioning	12
5.3.2 Low temperature conditioning	12
5.3.3 Artificial ageing	12
5.4 Test areas	13
5.4.1 General.....	13
5.4.2 Test area for class A.....	13
5.4.3 Test area for class B.....	13
5.5 Determination of shock absorbing capacity.....	14
5.5.1 Apparatus	14
5.5.2 Procedure	15
5.6 Determination of resistance to penetration	15
5.6.1 Apparatus	15
5.6.2 Procedure	16
5.7 Determination of retention system strength.....	16
5.7.1 Apparatus	16
5.7.2 Procedure	16
5.8 Determination of retention system effectiveness	16
5.8.1 Apparatus	16
5.8.2 Procedure	16
5.9 Test report	16
6 Marking	17

7	Information to be supplied by the manufacturer	17
	Annex ZA (informative) Relationship between this European Standard and the Essential Requirements of EU Directive 89/686/EEC	18
	Bibliography.....	19

Foreword

This document (EN 1077:2007) has been prepared by Technical Committee CEN/TC 158 “Head protection”, the secretariat of which is held by BSI.

This European Standard shall be given the status of a national standard, either by publication of an identical text or by endorsement, at the latest by February 2008, and conflicting national standards shall be withdrawn at the latest by February 2008.

This document supersedes EN 1077:1996.

This document has been prepared under a mandate given to CEN by the European Commission and the European Free Trade Association, and supports essential requirements of EU Directive 89/686/EEC.

For relationship with EU Directive, see informative Annex ZA, which is an integral part of this document.

According to the CEN/CENELEC Internal Regulations, the national standards organizations of the following countries are bound to implement this European Standard: Austria, Belgium, Bulgaria, Cyprus, Czech Republic, Denmark, Estonia, Finland, France, Germany, Greece, Hungary, Iceland, Ireland, Italy, Latvia, Lithuania, Luxembourg, Malta, Netherlands, Norway, Poland, Portugal, Romania, Slovakia, Slovenia, Spain, Sweden, Switzerland and United Kingdom.

Introduction

The intention of helmets is to reduce the risk of injury to the skull and part of the head surrounded by the helmet.

The protection given by a helmet depends on the circumstances of the accident and wearing a helmet cannot always prevent death or long term disability.

A proportion of the energy of an impact is absorbed by the helmet, thereby reducing the force of the blow sustained by the head. The structure of the helmet may be damaged in absorbing this energy and any helmet that sustains a severe blow should be replaced even if damage is not apparent.

To achieve the performance of which it is capable, and to ensure stability on the head, a helmet should be as closely fitting as possible consistent with comfort. In use it is essential that the helmet is securely fastened, with any chin strap under proper tension at all times.

Although the experience of the existing standard for alpine skiers is very good, it has become more and more obvious that there is a need for an alternative standard that can meet the demand from skiers and snowboarders who desire more ventilation and better hearing. This has resulted in two classes of helmets, class A and class B. Compared to class B, class A protects a larger area of the head and offers a higher degree of protection from penetration.

1 Scope

This European Standard is applicable to performance requirements and tests for two classes of helmets for alpine skiers, snowboarders and for similar groups, including children and participants in competitions. The standard comprises two different classes of protection, class A and class B.

Requirements and the corresponding methods of test, where appropriate, are given for the following:

- construction including field of vision;
- shock absorbing properties;
- resistance to penetration;
- retention system properties;
- marking and information.

2 Normative references

The following referenced documents are indispensable for the application of this document. For dated references, only the edition cited applies. For undated references, the latest edition of the referenced document (including any amendments) applies.

EN 960, *Headforms for use in the testing of protective helmets*

EN 13087-2:2000, *Protective helmets — Test methods — Part 2: Shock absorption*

EN 13087-3:2000, *Protective helmets — Test methods — Part 3: Resistance to penetration*

EN 13087-4:2000, *Protective helmets — Test methods — Part 4: Retention system effectiveness*

EN 13087-5:2000, *Protective helmets — Test methods — Part 5: Retention system strength*

EN 13087-6, *Protective helmets — Test methods — Part 6: Field of vision*

3 Terms and definitions

For the purposes of this document, the following terms and definitions apply.

3.1 protective helmet
item to be worn on the head, intended to absorb the energy of a foreseeable impact thus reducing the risk of injury to the head

3.2 shell
outer layer which provides part of the whole general form of the helmet

3.3 helmet type
category of helmets which does not differ in such essential respects as the materials or dimensions or construction of the helmet, or of the retention system

NOTE Helmet type may include a range of helmet sizes, provided that the thickness of the protective padding in each size in the range is at least equal to that in the helmet which, when subjected to the tests, satisfies the requirements of this standard.

3.4 padding

3.4.1 protective padding

material used to absorb impact energy

3.4.2 comfort padding

liner material provided for the wearer's comfort

3.4.3 sizing padding

liner material used for adjustment of the helmet size

3.5 retention system

complete assembly by means of which the helmet is maintained in position on the head, including any devices for adjustment of the system or to enhance the wearer's comfort

3.6 chin-strap

part of the retention system that passes under the wearer's jaw to keep the helmet in position

3.7 basic plane of the human head

plane at the level of the external ear opening (external auditory meatus) and the lower edge of the eye sockets (orbits)

3.8 basic plane of a headform

plane relative to the headform that corresponds to the basic plane of the human head

3.9 reference plane

construction plane parallel to the basic plane of the headform at a distance from it which is a function of the size of the headform

4 Requirements

4.1 Materials

For those parts of the helmet coming into contact with the skin the material used shall not be subject to any known appreciable alteration from contact with sweat or with substances likely to be found in toiletries.

Materials shall not be used which are known to cause skin disorders or other adverse effects on health. For a material not in general use advice as to its suitability shall be sought before its introduction.

Examples for documents which can be presented as evidence of chemical innocuousness are given in the NOTE.

NOTE The following list of documents is given for information and as examples of documents to be examined:

EN 1077:2007 (E)

- a) materials specifications;
- b) safety data sheets relating to the materials;
- c) information relating to the suitability of the materials for use with food, in medical devices, or other relevant applications;
- d) information relating to toxicological, allergenic, carcinogenic, toxic to reproduction or mutagenic investigations on the materials;
- e) information relating to ecotoxicological and other environmental investigations on the materials.

The examination should determine whether the claim that the materials are suitable for use in the protective helmet is justified. Particular attention needs to be paid to the presence of plasticisers, unreacted components, heavy metals, impurities and the chemical identity of pigments and dyes.

All metallic materials which could come into prolonged contact with the skin (e.g. buckles, fittings) are recommended to be tested according to EN 1811 for emission of nickel.

4.2 Construction

4.2.1 General

The helmet shall be so designed and shaped that parts of it (for example visor, rivets, ventilators, edges, fastening device etc.) are not likely to injure the user. This can be verified in accordance with 5.2.

NOTE Helmets should:

- have low weight;
- be easy to put on and take off;
- be usable with spectacles;
- not significantly interfere with the ability of the user to hear;
- have good durability and withstand normal handling;
- permit cleaning.

4.2.2 Retention system

4.2.2.1 General

Means shall be provided for retaining the helmet on the wearer's head. All parts of the retention system shall be securely attached to the system or to the helmet, so it would not come off during its use. This can be verified in accordance with Clauses 5.7 and 5.8

NOTE It is recommended that the opening mechanism is marked with red or orange colour.

The colour of any part of the retention system shall not be green.

4.2.2.2 Chin straps

The chin strap shall not include a chin cup.

Any chin strap shall be not less than 15 mm wide. This can be verified in accordance with 5.2.

Chin straps may be fitted with means of enhancing comfort for the wearer.

4.2.2.3 Fastening devices

Any retention system shall be fitted with a device to adjust and maintain tension in the system. The strength in the system shall be in accordance with 4.7.1.

4.3 Field of vision

When tested in accordance with EN 13087-6, there shall be no occultation in the field of vision bounded by angles as follows:

- horizontally 105°;
- upwards 25°;
- downwards 45°.

4.4 Extent of coverage

4.4.1 Class A

For Class A, when positioned in accordance with EN 13087-6 on a headform of appropriate size, the helmet shall cover at least the area above the line BCDEA' in Figure 1. No parts of the coverage may be detachable. Examples of different headform sizes are given in Table 1.

Those parts covering the area below the reference plane (shaded in Figure 1) shall be designed to give some protection against mechanical risks like abrasion. This can be verified in accordance with 5.2. Smaller openings for better hearing and/or ventilation are allowed.

4.4.2 Class B

For Class B, when positioned in accordance with EN 13087-6 on a headform of appropriate size, the helmet shall cover at least the area above the line BCA' in Figure 1.

Parts below the AA' plane (shaded part in Figure 1) are optional and may be detachable and/or removable. Examples of different headform sizes are given in Table 1.

Dimensions in millimetres

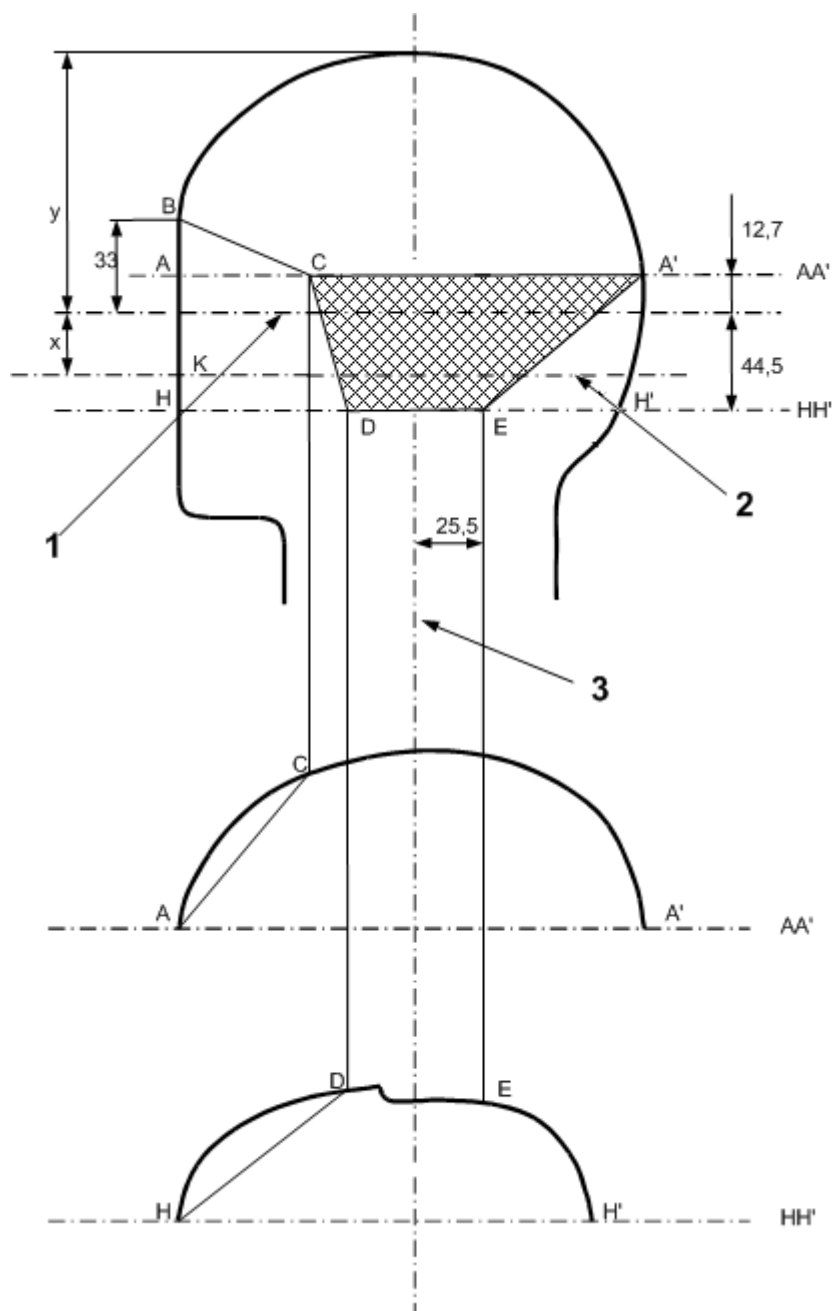

Key

- 1 reference plane
- 2 basic plane
- 3 central vertical axis

Figure 1 — Minimum extent of coverage: Measurements for different headform sizes

Table 1 — Examples of headforms

Dimensions in millimetres

Size designation (see EN 960)	Circumference of the headform at the reference plane	AC	HD	Y	X
495	495	84	89	89,7	23.5
535	535	88,5	92	96.0	25.5
575	575	93	95	102,4	27,5
605	605	97,5	98	107.2	29.0
625	625	100	100	110.2	30.0

NOTE The dimensions AC and HD correspond to the length of the chords measured with dividers.

4.5 Shock absorbing capacity

When tested in accordance with 5.5 the peak acceleration shall not, for each impact, exceed 250 g.

4.6 Resistance to penetration

When tested in accordance with 5.6 the point of the punch shall not touch the headform.

4.7 Retention system performance

4.7.1 Strength

When tested in accordance with 5.7, the dynamic extension shall not exceed 35 mm and the residual extension shall not exceed 25 mm. For this purpose, extension includes slippage of the fastening device. Following the test the retention system shall still permit the helmet to be released from the headform by normal operation of the release system.

Damage to the retention system shall be accepted provided that the above requirements are met.

4.7.2 Effectiveness

When tested in accordance with 5.8 the helmet shall not come off the headform.

4.8 Durability

After being tested the helmet shall not show damage that would cause an additional injury to the wearer's head (sharp edges, points etc.). This can be verified in accordance with 5.2.

5 Testing

5.1 Sampling

Only new and complete helmets as offered for sale shall be tested.

The duration between the date of manufacture and the date of testing shall be not less than 6 days.

Four samples of helmets are required for each test headform within the size range of each shell/protective padding size combination. If there is no test headform applicable to the shell/protective padding size combination, the next smaller available test headform shall be used.

Table 2 — Sequence of tests and number of tests per sample

Performance test	Sequence of tests	Sample number			
		1	2	3	4
Retention system effectiveness (5.8)	1 st	1	-	-	-
Shock absorbing capacity (5.5)	2 nd	1	2	3	-
Resistance to penetration (5.6)	3 rd	-	-	-	4
Retention system strength (5.7)	4 th	-	-	-	4

5.2 Inspection and determination of mass

If no test method is specified in this European Standard the compliance with the requirements have to be checked by visual and/or tactile examination.

The width of the chin strap shall be measured prior to testing and without any tension on the strap.

Determine the mass of the helmets of the same size submitted for testing. Calculate and record the mean value in grams rounded off to the nearest 10 g stating the size of the helmet.

5.3 Conditioning

5.3.1 Room conditioning

The sample shall be exposed to a temperature of $+ 20\text{ °C} \pm 2\text{ °C}$ for not less than 4 h.

5.3.2 Low temperature conditioning

The sample shall be exposed to a temperature of $- 25\text{ °C} \pm 2\text{ °C}$ for not less than 4 h.

5.3.3 Artificial ageing

The sample shall be exposed successively to:

- temperature of $+ 70\text{ °C} \pm 2\text{ °C}$ for not less than 48 h;
- room conditioning according to 5.3.1;
- ultraviolet irradiation by a 125 W xenon-filled quartz lamp for 48 h at a distance of 250 mm evenly over the exterior surface of the sample (e.g. by rotation);
- room conditioning according to 5.3.1.

An alternative method for artificial ageing is described in EN 13087-1:2000, Annex A. This method may be used as an alternative to the conditioning according to 5.3.3.

5.4 Test areas

5.4.1 General

Headforms shall comply with EN 960. Examples of measurements for different headform sizes are given in Table 1.

NOTE Free falling headforms are currently only commercially available in EN 960:1994 code letters A, E, J, M and O; equivalent to EN 960: 2006 sizes 495, 535, 575, 605 and 625. The 2006 edition of EN 960 should result in free falling headforms being made commercially available in the smaller sizes

Test areas for impact testing and penetration testing are given in 5.4.2 and 5.4.3.

5.4.2 Test area for class A

The test area for class A is given in Figure 2.

Dimensions in millimetres

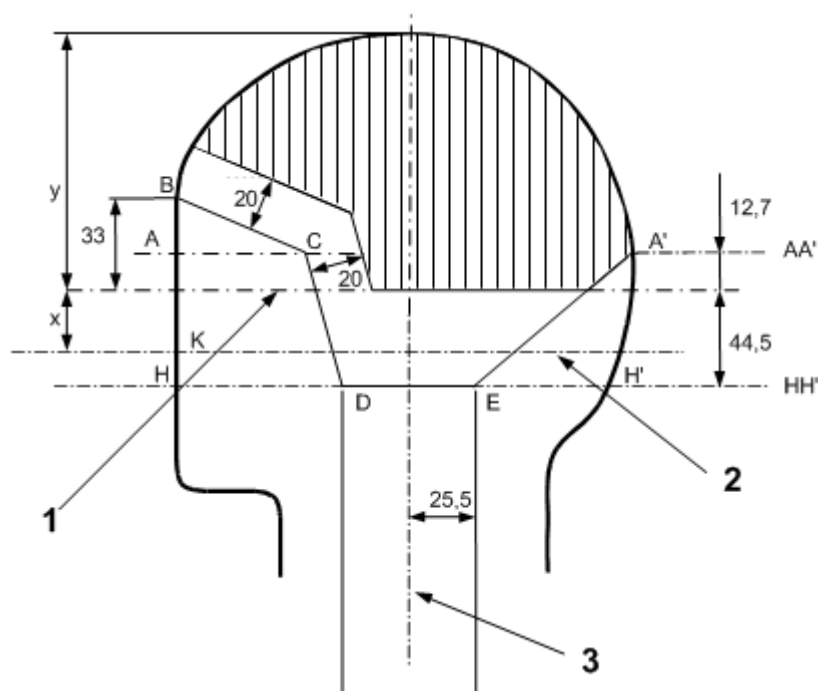

Key

- 1 reference plane
- 2 basic plane
- 3 central vertical axis

Figure 2 — Test area for class A

5.4.3 Test area for class B

The test area for class B is given in Figure 3.

Dimensions in millimetres

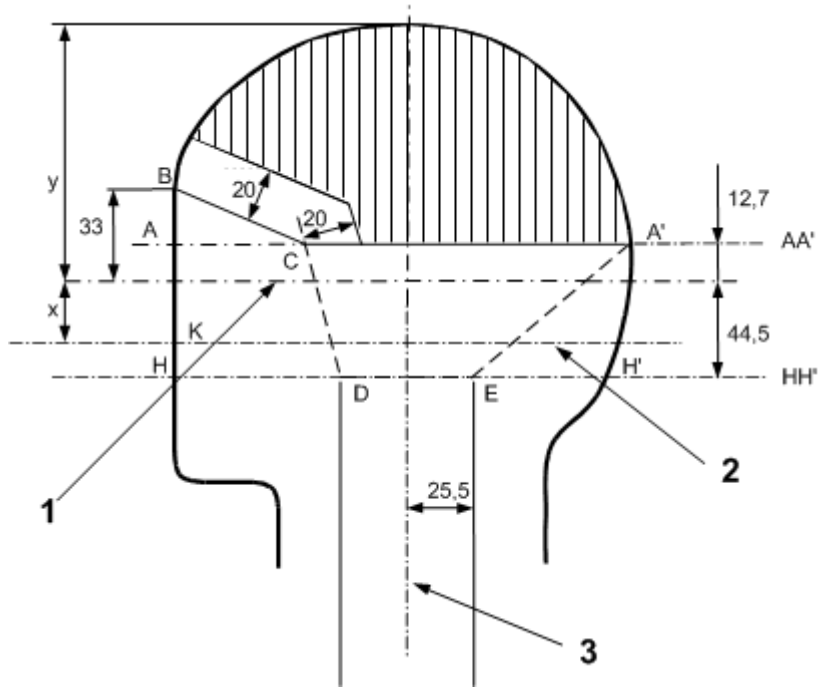

Key

- 1 reference plane
- 2 basic plane
- 3 central vertical axis

Figure 3 — Test area for class B

5.5 Determination of shock absorbing capacity

5.5.1 Apparatus

The apparatus shall be in accordance with EN 13087-2:2000, 5.3, falling headform method.

Only the flat anvil shall be used.

5.5.2 Procedure

5.5.2.1 Testing parameters

The testing shall be carried out according to Table 3.

Table 3 — Testing parameters

Sample	Conditioning
1	Ambient temperature
2	Low temperature
3	Artificial ageing

Within 1 min of its removal from conditioning (this time applies to temperature conditioning only), fit the helmet to the appropriate headform in the manner in which it is intended to be worn on the head, position the assembly so as to present the specified impact point over the anvil, then raise to the required drop height and release. All subsequent impacts shall be completed within 3 min from removal of the helmet from the conditioning chamber.

Impact each helmet on two sites.

The impact sites on the same sample shall be separated by a distance of minimum 100 mm measured as a chord with a divider.

The impacts shall be directed towards the centre of gravity of the headform.

The velocity of the headform shall be $5,42 \text{ m/s}^{+0}_{-0,1}$ (this is theoretically equivalent to a drop height of 1 500 mm).

The velocity of the headform shall be measured at a distance between 60 mm and 10 mm prior to impact, to an accuracy of 1 %.

The testing shall be conducted under recorded conditions of room temperature.

Applicable conditioning shall be made according to 5.3.

5.5.2.2 Recording

The measured results (g_{\max}) shall be recorded in tabular form completed with time/acceleration diagrams.

The extent of any damage as described in 4.8 shall also be recorded.

5.6 Determination of resistance to penetration

5.6.1 Apparatus

The apparatus shall be in accordance with EN 13087-3:2000, 5.3.3.

The conical striker described in EN 13087-3:2000, 5.3.3 a) shall be used. The test block described EN 13087-3:2000, 5.3.2 shall be used.

EN 1077:2007 (E)

5.6.2 Procedure

The procedure shall be in accordance with EN 13087-3:2000, 5.4. The helmets shall first undergo the process of conditioning according to 5.3, selected by the test laboratory, which is likely to give the least satisfactory results.

Perform the test on sample 4 (see Table 2).

The velocity of the striker shall be one of the following:

- a) 3,84 m/s ⁺⁰ _{-0,1} m/s (this is theoretically equivalent to a drop height of 750 mm) for class A helmets;
- b) 2,71 m/s ⁺⁰ _{-0,1} m/s (this is theoretically equivalent to a drop height of 375 mm) for class B helmets.

Each helmet shall be impacted three times, each time in a different site. The sites shall be at least 100 mm apart measured as chords with dividers.

5.7 Determination of retention system strength

5.7.1 Apparatus

The apparatus shall be in accordance with EN 13087-5:2000, 5.3.2.

5.7.2 Procedure

The procedure shall be in accordance with EN 13087-5:2000, 5.3.3.

Sample 4 (see Table 2) shall be used for the test. Fit the helmet to the appropriate headform in the manner in which it is intended to be worn on the head.

Release the drop weight and allow it to drop from a height of (200 ± 5) mm.

5.8 Determination of retention system effectiveness

5.8.1 Apparatus

The apparatus shall be in accordance with EN 13087-4:2000, 5.3.

5.8.2 Procedure

The procedure shall be in accordance with EN 13087-4:2000, 5.4.

Hook the twisted steel wire to the rear part of the helmet.

Release the drop weight and allow it to fall (175 ± 5) mm.

5.9 Test report

The test report shall contain at least the following information:

- a) identification details of the helmets tested including range of sizes and masses;
- b) results of the tests according to 5.2, 5.5, 5.6, 5.7 and 5.8;
- c) date of testing;
- d) name of the test house.

6 Marking

Each helmet shall be permanently marked in such a way that the following information is easily legible by the user and is likely to remain legible throughout the life of the helmet:

- number of this European Standard, i.e. EN 1077;
- name or trademark of the manufacturer;
- designation of the model;
- designation (on class A helmet only): 'helmet for alpine skiers and for snowboarders – class A';
- designation (on class B helmet only): 'helmet for alpine skiers and for snowboarders – class B';
- size or size range of the helmet, quoted as the circumference (in cm) of the head which the helmet is intended to fit;
- weight of the helmet (the average mass in grams of the helmet size in question rounded to the nearest 50 g);
- year and quarter of manufacture.

7 Information to be supplied by the manufacturer

With every helmet distinct information in the language(s) of the country of sale shall be furnished as follows:

- maintenance, cleaning and storage;
- suitable accessories;
- warning if the shell is made of a material that is known to be adversely affected by contact with hydrocarbons, cleaning fluids, paints, transfers or other extraneous additions;
- that the helmet shall be adjusted to fit the wearer;
- how the helmet should rest on the head to ensure the intended protection (e.g. that it should be placed so as to protect the forehead and not be pushed too far back over the back of the head);
- that a helmet subjected to violent impact shall be discarded;
- the following text:
'Class A and class B helmets are for alpine skiers, snowboarders and similar groups. Class A helmets offer comparatively more protection. Class B helmets may offer greater ventilation and better hearing, but protect a smaller area of the head and give a lesser degree of protection from penetration.'

Annex ZA (informative)

Relationship between this European Standard and the Essential Requirements of EU Directive 89/686/EEC

This European Standard has been prepared under a mandate given to CEN by the European Commission and the European Free Trade Association to provide a means of conforming to Essential Requirements of the New Approach Directive 89/686/EEC.

Once this standard is cited in the Official Journal of the European Communities under that Directive and has been implemented as a national standard in at least one Member State, compliance with the clauses of this standard given in Table ZA.1 confers, within the limits of the scope of this standard, a presumption of conformity with the corresponding Essential Requirements of that Directive and associated EFTA regulations.

Table ZA — Correspondence between this European Standard and Directive 98/37/EC

Clause(s)/subclause(s) of this EN	Essential Requirements (ERs) of Directive 89/686/EEC, Annex II	Qualifying remarks/Notes
4.4	1.1.2.2 Classes of protection appropriate to different levels of risk	
4.2.2.1, 4.2.2.2, 4.2.2.3, 4.4, 4.7.2, 4.8	1.2.1 Absence of risk of other inherent nuisance factors	
4.1	1.2.1.1 Suitable constituent materials	
4.2.1	1.2.1.2 Satisfactory surface condition of all parts of PPE in contact with the user	
4.3	1.2.1.3 Maximum permissible user impediment	
4.2.2.1, 7	1.3.1 Adaptation of PPE to user morphology	
5.3	1.3.2 Lightness and design strength	
6, 7	1.4 Information supplied by the manufacturer	
4.2.2.3, 4.7.1	2.1 PPE incorporating adjustment systems	
5.3.3, 6, 7	2.4 PPE subject to ageing	
6, 7	2.12 PPE bearing one or more identification or recognition marks directly or indirectly relating to health and safety	
4.5, 4.6	3.1.1 Impact caused by falling or projecting objects and collision of parts of the body with obstacle	

WARNING: Other requirements and other EU Directives may be applicable to the product(s) falling within the scope of this standard.

Bibliography

- [1] EN 1811, *Reference test method for release of nickel from products intended to come into direct and prolonged contact with the skin*
- [2] EN 13087-1:2000, *Protective helmets — Test methods — Part 1: Conditions and conditioning*

For information regarding the development of standards contact:

Asociación Española de Normalización
Génova, 6
28004 MADRID-España
Tel.: 915 294 900
info@une.org
www.une.org

For information regarding the sale and distribution:

AENOR INTERNACIONAL S.A.U.
Tel.: 914 326 160
normas@aenor.com
www.aenor.com



Spanish standardization body in:



ANNEX 2. SOLIDWORKS SIMULATIONS STATIC ANALYSIS DOCUMENT

Simulation of HELMET ABS/PC SHELL

Date: Monday, January 20, 2025

Designer: Ane Viteri

Study Name: Static Analysis 1

Analysis Type: Static Analysis

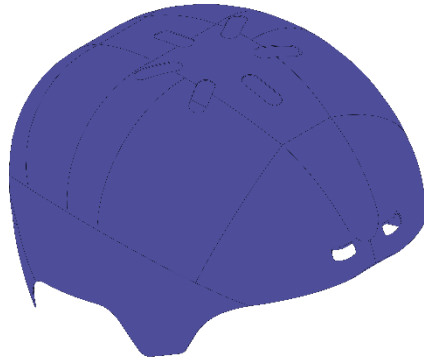

Description

This document serves as a complementary analysis to the static evaluation of the ski helmet shell made from Acrylonitrile Butadiene Styrene (ABS) and Polycarbonate (PC). The design features a cutout in the crown area, which is considered the most vulnerable section, although additional material is incorporated towards the end of the design. The viability of this component is assessed based on its hardness and structural integrity. For this analysis, forces have been applied around the vulnerable area to rigorously test its resilience.

INDEX

Description	1
Assumptions	2
Model Information	2
Properties.....	3
Units.....	4
Material properties	4
Loads and Fixtures	5
Connector Definitions.....	5
Contact Information.....	6
Mesh information	7
Maximum Ele	7
Mesh Quality Plot:	7
Maximum.....	7
%	7
% of Distorted Elements (Jacobian):	7
Time to Complete Mesh (hh:mm:ss):	7
Computer Name:	7
Fuerzas resultantes	8
Study results	9
Conclusion	12



Assumptions

- Helmet is made of ABS through injection molding.
- Structural analysis will showcase a standard standing scenario in where no issues will appear to the structural integrity of the helmet.

Model Information

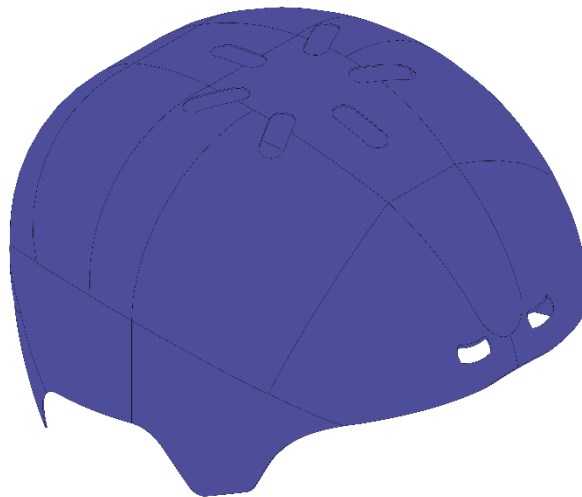

Model Name: HELMET ABS/PC SHELL
Actual configuration: Default

Solids

Document Name and Reference	Document Name and Reference	Document Name and Reference	Document Name and Reference
-----------------------------	-----------------------------	-----------------------------	-----------------------------



<p>Solid 1</p> 	<p>Solid</p>	<p>Mass: 1.49284 kg Volume: 0.00146356 m³ Density: 1.020 kg/m³ Weight: 14.6298 N</p>	<p>C:\Users\ane.viteri\Desktop\ane\ANE\HELMET PC SHELL.SLDPRT Jan 20 09:12:33 2025</p>
--	--------------	--	--

Properties

Study Name	Static Analysis 1
Analysis Type	Static Analysis
Mesh Type	Solid Mesh
Thermal effect:	Activate
Thermal Option	Include Thermal loads
Zero Stress Temperature	298 Kelvin
Include Fluid Pressure Effects from SOLIDWORKS Flow Simulation	Deactivate
Solver Type	FFEPlus
Inplane Stress Stiffening Effect	Deactivate
Soft Spring	Activate
Inertial Relief	Activate
Incompatible Bonding Options	Automatic
Large Displacement	Deactivate
Calculate Free Body Forces	Activate
Friction	Deactivate
Use Adaptive Method	Deactivate
Results folder	SOLIDWORKS Document (C:\Users\ane.viteri\Desktop\ane\ANE)



Units

Unit System:	Unit System:
Length / Displacement	Length / Displacement
Temperature	Temperature
Angular Velocity	Angular Velocity
Pressure / Stress	Pressure / Stress

Material properties

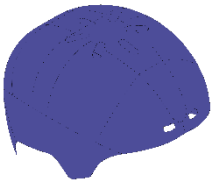
Model Reference	Properties	Components
	Model Reference: ABS/PC Model Type: Linear Elastic Isotropic Default Failure Criterion: Unknown Elastic Modulus: 3e+07 N/m ² Elastic Modulus: 2e+09 N/m ² Poisson's Ratio: 0,394 Density: 1.020 kg/m ³ Shear Modulus: 3,189e+08 N/m ²	Solid 1(Solid 1)(HELMET PC SHELL)
Curve data :N/A		

Loads and Fixtures

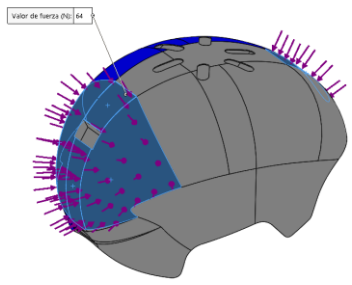
Load name	Picture	Detalles de carga
Force-1		<p>Entities: 5 faces Type: Apply normal force Value: 64 N</p>

Connector Definitions

Only connectors in the element consist on non-invasive and non-penetrant ABS adapted glue that will join both outer surface hole and small in-cabin ABS walls in where to insert LED case later on.

These help force the walls against any impact.

Contact Information

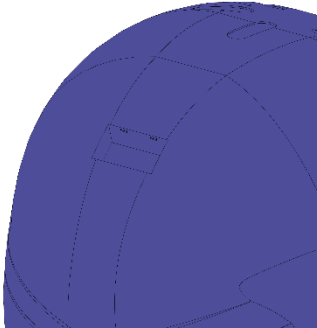
Contact name	Contact picture	Contact Properties
Contact-1		Type: No penetration contact pair Entities: 8 edges, 8 faces Advanced: Node to surface



Mesh information

Mesh Type:	Solid Mesh
Mesher Used:	Curvature-based mesh
Jacobian Points:	4 Points
Maximum Element Size:	25.3637 mm
Minimum Element Size:	5.07273 mm
Mesh Quality Plot:	High-order quadratic elements

Mesh information - Details

Total Nodes:	26011
Total Elements:	12695
Maximum Aspect Ratio:	93.118
% of Elements with Aspect Ratio < 3:	1,77%
% of Elements with Aspect Ratio > 10:	50,4%
% of Distorted Elements (Jacobian):	0
Time to Complete Mesh (hh:mm:ss):	00:00:07
Computer Name:	GCGDVT2



Nombre del modelo: HELMET PC SHELL
Nombre de estudio: Análisis estático 2(-Predeterminado-)
Tipo de malla: Malla sólida

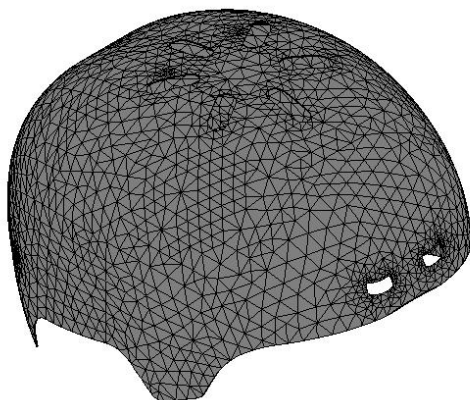

Fuerzas resultantes

Reaction forces

Selection Set	Units	Sum X	Sum Y	Sum Z	Resultant
Entire model	N	0	0	0	1e-33

Reaction moments

Selection Set	Units	Sum X	Sum Y	Sum Z	Resultant
Entire Model	N.m	0	0	0	0

Study results

Name	Type	Min.	Max.
Stresses 1	VON: von Mises Stress	2,013e+03 N/m ² Node: 82	7,114e+05 N/m ² Node: 5911

Nombre del modelo: HELMET PC SHELL
Nombre de estudio: Análisis estático 2-(Predeterminado-)
Tipo de resultado: Análisis estático tensión nodal Tensiones1
Escala de deformación: 1

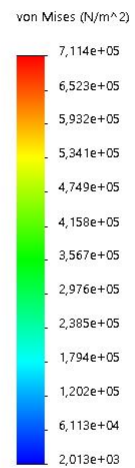
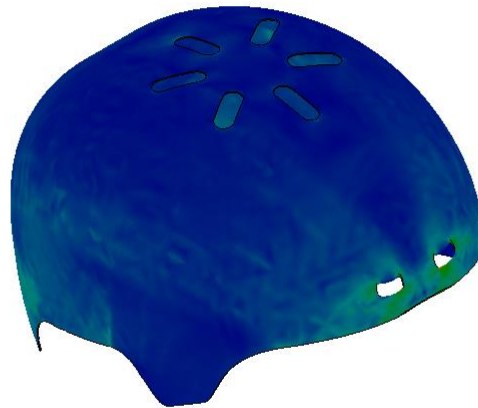

HELMET ABS/PC SHELL-Static Analysis 1-Stresses - Stresses1

Name	Type	Min.	Max.
Displacement	URES: Resultant displacements	4,055e-01 mm Node: 22415	3,233e+00 mm Node: 6256

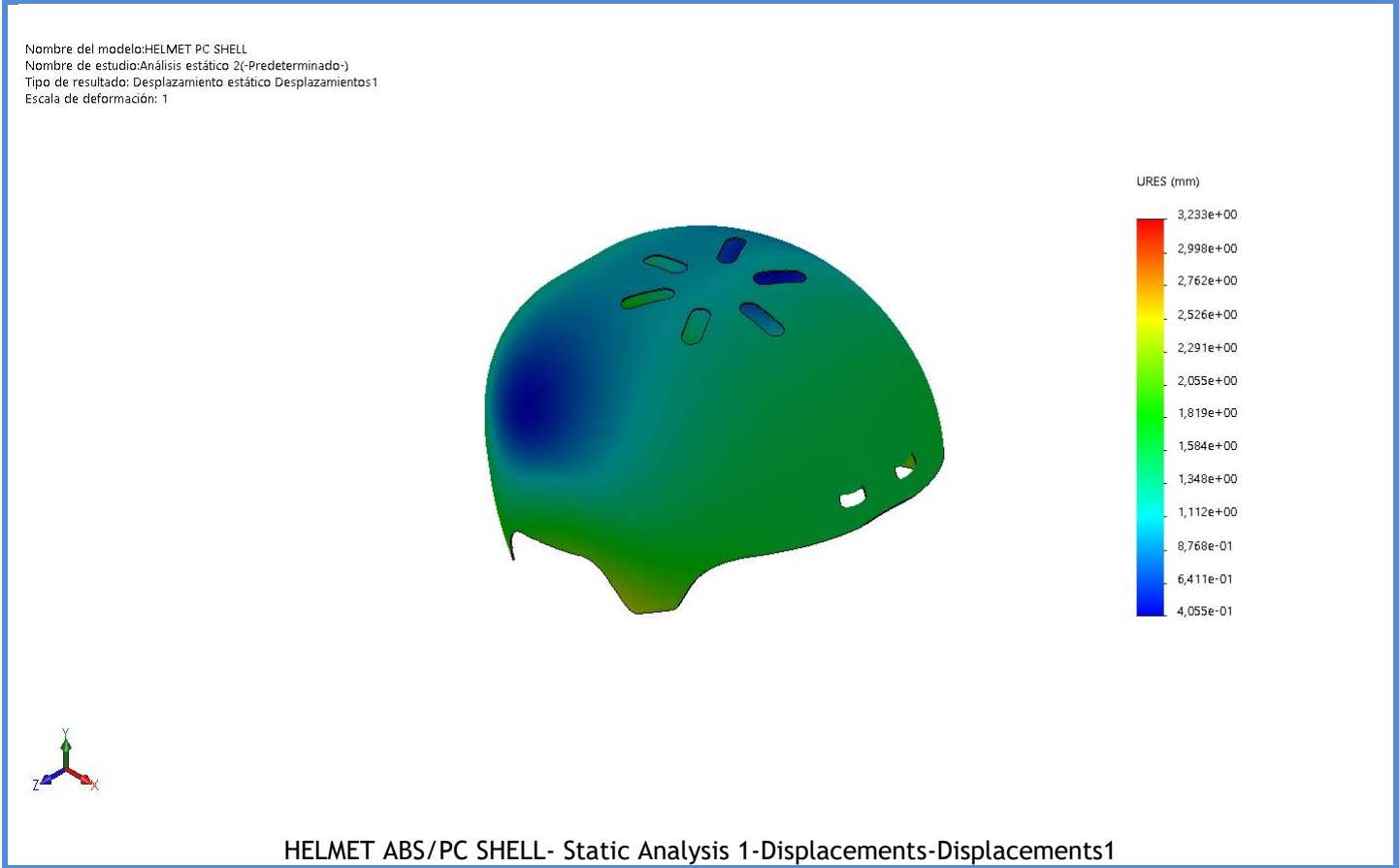

Name	Type	Min.	Max.
Strains1	ESTRN: Equivalent Strain	1,126e-06 Element: 10051	2,025e-04 Element: 3538

Nombre del modelo: HELMET PC SHELL
Nombre de estudio: Análisis estático 2-(Predeterminado-)
Tipo de resultado: Deformación unitaria estática Deformaciones unitarias1
Escala de deformación: 1

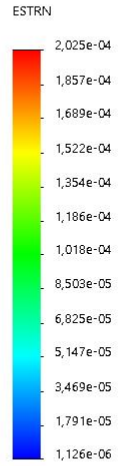
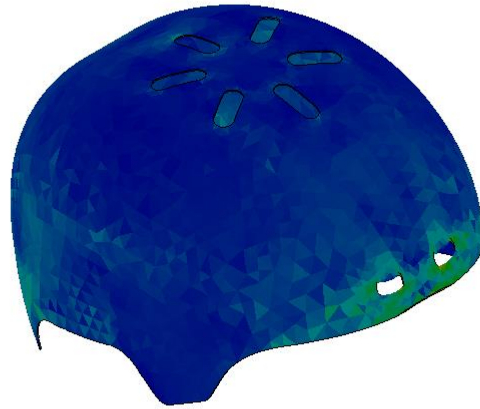

HELMET ABS/PC SHELL- Static Analysis 1-Strains-Strains1

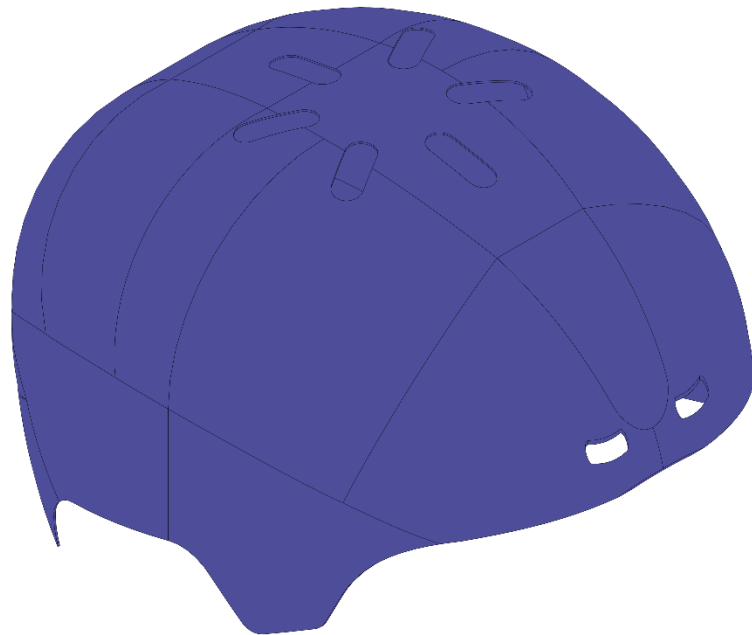

Image-1

Conclusion

In conclusion, the structural analysis of the ski helmet shell made from Acrylonitrile Butadiene Styrene (ABS) and Polycarbonate (PC) shows that the design works well. The analysis assumes that ABS is used through injection molding and that there are no issues with the helmet's structural integrity in a standard standing scenario. The model, called "HELMET ABS/PC SHELL," was analyzed under static conditions with a solid mesh



type and included thermal effects. The material properties of ABS, such as its density of 1.020 kg/m^3 and elastic modulus of $2\text{e}+09 \text{ N/m}^2$, were important in assessing the helmet's performance. The analysis showed that the helmet shell, with a mass of 1.49284 kg and a volume of 0.00146356 m^3 , maintained its structural integrity under the applied forces.

The results indicate that the helmet shell can withstand the applied forces without losing its structural integrity. The von Mises stress values ranged from $2.013\text{e}+03 \text{ N/m}^2$ to $7.114\text{e}+05 \text{ N/m}^2$, and the displacements were minimal, with a maximum of 3.233 mm . The equivalent strain values were also within acceptable limits, ensuring the helmet's durability and safety. The connectors, made of non-invasive and non-penetrant ABS-adapted glue, effectively joined the outer surface hole and small in-cabin ABS/PC walls, enhancing the helmet's impact resistance. Overall, the analysis confirms that the ABS helmet shell design is structurally sound and capable of providing the necessary protection for ski helmet applications.

ANNEX 3. SOLIDWORKS SIMULATIONS DROP ANALYSIS DOCUMENT

Simulation of HELMET ABS/ PC SHELL

Date: monday, February 24t, 2025

Designer: ANE VITERI BELZA

Study name: Drop Test

Analysis Type: Drop Test

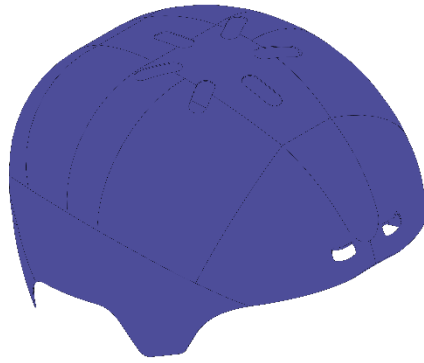

Index

Description	1
Assumptions	2
Study properties	3
Unidades	3
Material Properties	4
Contact information.....	4
Mesh information	5
Study results	6
Conclusion	8

Description

In this simulation, we evaluated the performance of a ski helmet shell featuring an opening at the crown, designed to house a compartment containing electronic components. The helmet is manufactured using injection-molded ABS with PC reinforcements, ensuring a balance of strength and flexibility. The simulation aimed to replicate real-world conditions by incorporating the weight of an adult male's head, standardized at 6.5 kg, which typically ranges between 6 and 7 kg. The subject's height was set at an average of 1.70 meters, and the impact scenario involved a fall from this height onto a "rigid" surface, simulated to mimic hard-packed snow.

The study meticulously considered the dynamic response of the helmet under these conditions, focusing on the structural integrity and energy absorption capabilities of the ABS/PC composite material. The rigid ground simulation provided a worst-case scenario to assess the helmet's protective performance. The results from this simulation are crucial for understanding the helmet's behavior under impact and ensuring the safety of the electronic components housed within the crown compartment. This comprehensive analysis provides valuable insights into the helmet's design efficacy and potential areas for improvement.



Assumptions

- Human head weight = 6,5kg * 9.81 m/s².
- Human height = 1,70m.
- Impact will not affect effectiveness of helmet ABS/PC shell.
- Design is adequate for foreign applications.

Model Information

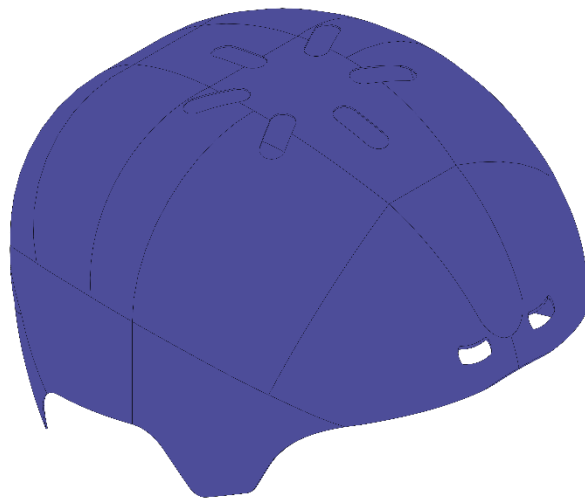

Model Name: HELMET ABS/PC SHELL
Current Configuration: Default

Solids

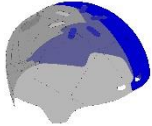
Document name and reference	Document name and reference	Document name and reference	Document name and reference
Cortar-Extruir9 	Solid	Mass: 0,5667 kg Volume:0,0014642 m ³ Density:1.070 kg/m ³ Weight:1,53537 N	C:\Users\ane.viteri\Desktop\ane\ANE\3D model\HELMET PC SHELL.SLDPRT Feb 24 14:48:08 2025



Study properties

Study name	Drop Test 1
Analysis type	Drop Test
Mesh type	Solid Mesh
Large displacement	Enabled
Results Folder	SOLIDWORKS document (C:\Users\ane.viteri\Desktop\ane\ANE)

Configuration information

Type	Impact velocity
Impact Velocity	13.8889 m/sec
Impact Velocity Reference	Edge<2>
Gravity	9.81 m/s ²
Gravity Reference	Edge<1>
Friction Coefficient	0
Ground Stiffness	Rigid Ground
Critical Damping Ratio	1

Solutions

Time Post-Impact	628.3 microsec
Save Results From	0 microsec
Number of Traces	10
Graph Steps per Trace	20
Number of Vertices	0

Units

Unit System:	Metric (MKS)
Length / Displacement	mm
Temperature	Kelvin
Angular Velocity	Rad/sec
Pressure / Stress	N/m ²

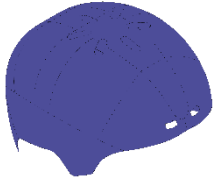

Material Properties

Model reference	Properties	Components
	Name: ABS PC Model type: Linear Isotropic elastic model Default error criterion: Unknown Tensile limit: 4e+07 N/m ² Elastic modulus: 2,41e+09 N/m ² Poisson's ratio: 0,3897 Density: 1.070 kg/m ³ Shear modulus: 8,622e+08 N/m ²	Solid 1(Solid 1)(HELMET ABS/PC SHELL)
Curve data: N/A		

Contact information

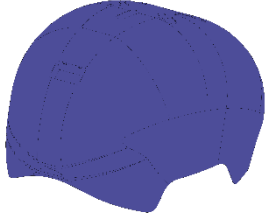
Contact	Contact image	Contact properties
Contact-1		Type: No penetration contact Pair Entities: 12 edges, 8 faces Advanced: Node to surface

Mesh information

Mesh type	Solid mesh
Mesher used:	Curvature based mesh
Jacobian points	4 Points
Maximum element size	25,3718 mm
Minimum element size	5,07436 mm
Mesh quality plot:	High-order quadratic elements

Mesh information - Details

Total nodes	27461
Total elements	32095
Maximum Aspecto ratio	82,441
% of elements with aspecto ratio < 3	1,93
% of elements with aspecto ratio > 10	48,1
% of distorted elements (Jacobian)	0
Mesh completion time (hh:mm:ss):	00:00:06
Computer name:	GCGDVT2

Nombre del modelo: HELMET PC SHELL
Nombre de estudio: Caída 3(-Predeterminado-)
Tipo de malla: Malla sólida

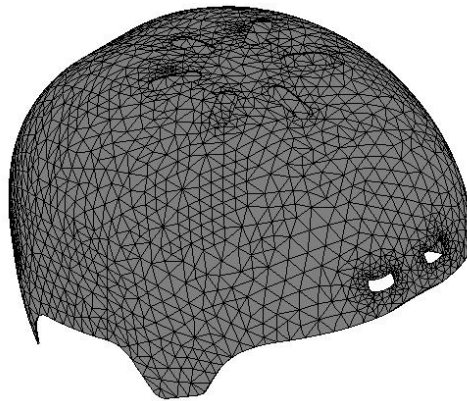

Study results

Name	Type	Min.	Max.
Stresses 1	VON: Von Mises Stress	8,400e+04 N/m ² Node: 21573	8,964e+07 N/m ² Node: 121

Nombre del modelo: HELMET PC SHELL
 Nombre de estudio: Caída 3(-Predeterminado-)
 Tipo de resultado: Tensiones1
 Intervalo: 10 tiempo: 628,298 Microsegundos
 Escala de deformación: 1

von Mises (N/m²)

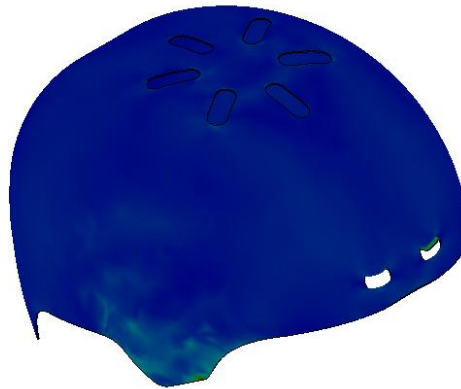
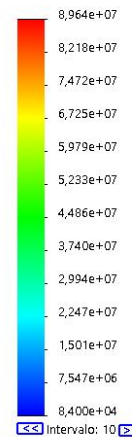

HELMET ABS/PC SHELL-Drop 1-Stresses-Stresses1

Name	Type	Min.	Max.
Displacements1	URES: Resultant Displacements	5,708e+00 mm Node: 1300	0,549e+01 mm Node: 122



Nombre del modelo: HELMET PC SHELL
 Nombre de estudio: Caída 3-(Predeterminado-)
 Tipo de resultado: Desplazamientos1
 Intervalo: 10 tiempo: 628,298 Microsegundos
 Escala de deformación: 1

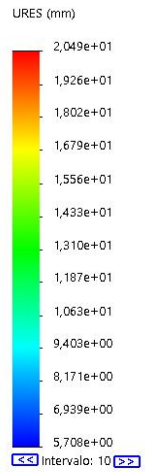

HELMET ABS/PC SHELL-Drop 1-Displacements - Displacements 1

Name	Type	Min.	Max.
Strains 1	ESTRN: Equivalent Strain	2,633e-05 Element: 8548	2,797e-02 Element: 666



Nombre del modelo: HELMET PC SHELL
Nombre de estudio: Caída 3-(Predeterminado)
Tipo de resultado: Deformaciones unitarias1
Intervalo: 10 tiempo: 628,298 Microsegundos
Escala de deformación: 1

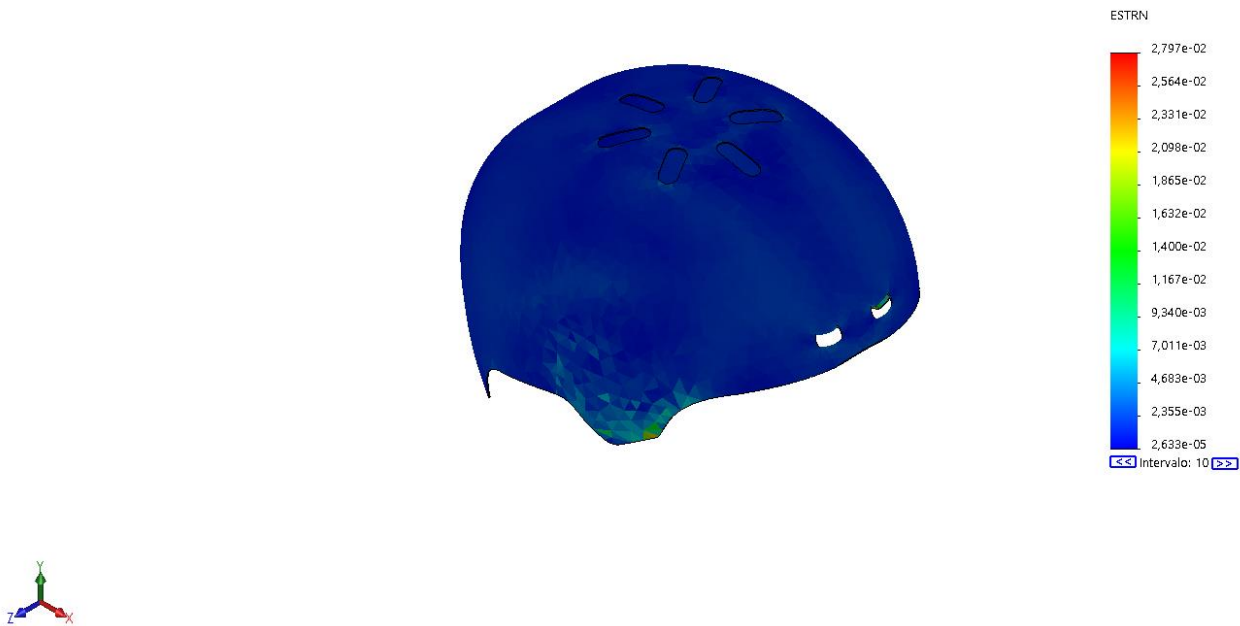

HELMET ABS/PC SHELL-Drop 1-Strains - Strains 1

Conclusion

The drop test simulation utilized a solid mesh with large displacement enabled, and the results were stored in a SOLIDWORKS document. The model, configured as a default solid with a mass of 0.5667 kg and a density of 1.070 kg/m³, was subjected to an impact velocity of 13.8889 m/sec, simulating a fall from a height of 1.70 meters onto a rigid surface representing hard-packed snow.

The material properties of the helmet, made from injection-molded ABS with PC reinforcements, were critical in assessing its structural integrity. The von Mises stress results ranged from 8.400e+04 N/m² to 8.964e+07 N/m², while the resultant displacements varied from 5.708 mm to 0.549e+01 mm. The equivalent strain values indicated minimal deformation, with a maximum of 2.797e-02. These results demonstrate that the helmet can effectively absorb and dissipate the energy from an impact, ensuring the safety of the electronic components housed within the crown compartment.

Based on the simulation data, the design of the HELMET ABS/PC SHELL has successfully passed the drop test, confirming its suitability for practical application. The helmet's robust construction and material composition provide adequate protection, making it a reliable choice for safeguarding both the wearer and the integrated electronic elements during skiing activities.



ANNEX 4. BILL OF MATERIALS BUY COMPONENT DATASHEETS

FIJA+PLUS TURBO

DESCRIPCIÓN

Adhesivo elástico de polímero de nueva generación MST que cura por humedad.

PROPIEDADES

- Temperatura de aplicación +5°C a +40°C
- Resistencia a la temperatura -40°C a +90 °C
- Alta calidad
- Alto agarre inicial
- Resistencia al envejecimiento
- Resistencia a la intemperie
- Elevada resistencia a la radiación UV
- Bajo olor
- No merma
- No amarillea
- Interior/Exterior
- Elasticidad permanente
- Pintable
- Exento de disolventes
- Exento de isocianatos

APLICACIONES

- Pegados de planchas galvanizadas, metales férreos o no férreos, elementos de caravanas o camiones.
- Pegado de paneles, tejas, placas, azulejos, espejos, apliques, molduras, fijación de objetos.
- Sellado de cristales, canalizaciones, cubiertas, tejas, marcos PVC/obra.

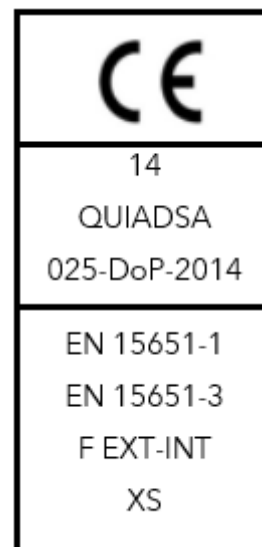

Envases	Capacidad	Presentación	Caducidad
Cartuchos	290 ml	12 uds	18 meses
Tubo	125 ml	12 uds	18 meses

COLORES

Blanco, gris, marrón y negro.

*Consultar disponibilidad de otros colores y formatos.

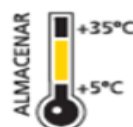

**Conservar en lugar fresco y seco

CARACTERÍSTICAS TÉCNICAS

En forma de suministro:

Característica	Método	Unidades	Valores
Densidad		g/ml	1,41
Consistencia			Pasta tixotrópica
Sólidos	2 horas a 120 °C	%	98
Formación de piel	20 °C	min	8
Tiempo de secado	20 °C (cordón 2mm)	min	60

Producto curado:

Característica	Método	Unidades	Valores
Módulo 100%	DIN 53504	N/mm ²	2,30
Carga a la rotura	DIN 53504	N/mm ²	4
Elongación a la rotura	DIN 53504	%	250
Dureza	DIN 53505	Shore A	65

ADHESIÓN

Excelente adhesión sobre:

Hormigón, ladrillo, madera, obra vista, piedra natural o artificial, cerámica, vidrio, metales como aluminio, hierro, zinc, galvanizados, etc., la mayoría de los plásticos termoplásticos (excepto polietileno o PTFE) o termoendurecibles.

Buena adhesión sobre superficies húmedas.

RESISTENCIA QUÍMICA

Resiste a agua, disolventes alifáticos, ácidos inorgánicos diluidos y álcalis, aceites y grasas.

Mala resistencia a disolventes aromáticos, a ácidos concentrados y a hidrocarburos clorurados

LIMPIEZA

Limpiar con el producto BRIK-CEN S 890, cuando el producto esté sin endurecer.

Una vez endurecido la limpieza es de forma mecánica.

ACCESORIOS RECOMENDADOS

Pistola P-1441



MODO DE EMPLEO

Las superficies sobre las que se apliquen deben ser firmes y estar completamente limpias. Puede aplicarse sobre superficies húmedas.

El sellador/adhesivo se puede pintar. El momento más idóneo para el pintado es inmediatamente después de la formación de piel de este, aproximadamente 10 minutos después de haber sido aplicado.

Se puede usar en proximidad a cabinas de pintado.

Debido a la gran variedad de pinturas presentes en el mercado, recomendamos testar la compatibilidad de esta con el sellador/adhesivo.

Sellado: aplicar mediante una pistola, neumática o manual, formando un cordón continuo y evitando formar bolsas de aire.

A continuación, alisar con una espátula humedecida en agua jabonosa

Dimensión de la junta

La junta debe ser diseñada según la capacidad de movimiento del sellador. En general, la junta debe tener un espesor comprendido entre 5-25 mm.

La relación entre anchura y profundidad dependerá del ancho de la junta.

En general, para juntas de más de 10mm, la relación entre anchura y la profundidad debe ser aproximadamente 2:1 respectivamente.

Para juntas de menor tamaño, la relación debe ser aproximadamente 1:1.

Ancho (mm)	10	15	20	25
Profundidad (mm)	8	8	10	12
Rendimiento (m)	3,75	2,5	1,5	1

Pegado: aplicar sobre una de las superficies a unir formando cordones según las dimensiones de las piezas. Presionar fuertemente sobre la otra superficie durante varios segundos.

RENDIMIENTO SELLADOR

$L = 290 / (a \cdot p)$

L: longitud del sellado en m.

a: ancho de la junta en mm.

p: profundidad de la junta en mm.

RENDIMIENTO ADHESIVO

Aproximadamente 1 cartucho por 2 m²

SEGURIDAD E HIGIENE

Ficha de seguridad a disposición del cliente.

NOTA

La información proporcionada en esta ficha técnica y en particular las recomendaciones relativas a la aplicación, uso final del producto y asesoramiento del departamento técnico (de forma verbal o escrita) son dadas de buena fe y basadas en nuestro conocimiento actual y experiencia (cuando los productos son correctamente almacenados, utilizados y aplicados en condiciones óptimas dentro de su vida útil).

En la práctica, las posibles diferencias en los materiales, soportes y condiciones reales en el lugar de aplicación son tales, que no se puede deducir de la información, de este documento ni de cualquier recomendación escrita o verbal, ninguna garantía en términos de comercialización o idealidad para propósitos particulares ni obligación alguna fuera de cualquier relación legal que pudiera existir.

El usuario de los productos debe realizar las pruebas para comprobar su idoneidad de acuerdo con el uso que le quiere dar. Nuestra garantía se limita exclusivamente a asegurar la calidad del producto suministrado conforme a nuestros estándares de calidad declinando toda responsabilidad en lo que se refiere a resultados obtenidos y a posibles perjuicios procedentes de un uso incorrecto o no adecuado.

En el caso que Quiadsa fuera considerada responsable en virtud de cualquier fundamento jurídico, la responsabilidad de esta en ningún caso superará el importe de la entrega correspondiente. Quiadsa se reserva el derecho de cambiar las propiedades de sus productos. Los usuarios deben de conocer y utilizar la versión última y actualizada de las fichas técnicas de los productos, mediante su solicitud a nuestro departamento o consulta en la web www.quiadsa.com

1015 MIPS FOAM







PRODUCT PARAMETERS

thickness 0.63in/15.9mm



Name: 503A helmet light	Battery: 200MAH chargeable lithium battery
Rated voltage: 3.7V	Working range: 2.6V-4.2V
Standby current: <2UA	Working current: 30MAH±2MA
Working temperature: -20°C—+55°C	Charging current: 150MA±10MA
Executive standard: Q/CBSTKD002-2017	Charging interface: Micro usb

Características técnicas

Referencias

Referencia ⓘ MRKEAN-6976919840317

EAN ⓘ 6976919840317

Marca ⓘ CHRONUS

Modelo ⓘ SW-0010

Características Físicas

Color ⓘ Negro

Peso ⓘ 0.5kg

Medidas ⓘ Não específico

Material ⓘ Não específico

Cantidad ⓘ 1

Más Información

Marcado CE Si

Características Específicas

Modalidad ⓘ Motociclismo

96 LEDs Panel Evaluation Board based on LED1202

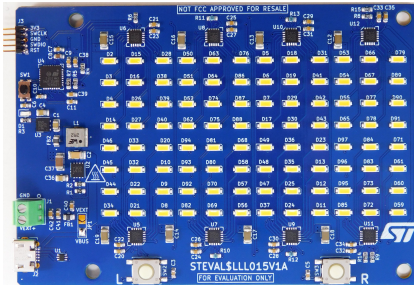

Features

- Eight devices with 12-channel each
- STM32L072 on-board microcontroller
- USB connector for communication with the STSW-LED1202GUI PC SW
- Programmable with basic scripts

Description

The STEVAL-LLL015V1 is a board with 96 individually driven LEDs controlled by eight LED1202 LED drivers. The drivers are connected to the same I2C bus and share a master clock for common sequence timing. Each LED can be programmed to perform an individual 8-step pattern sequence (single shot or repeated). The panel is configured using the STSW-LED1202GUI, and the user can program several light effects using a basic language interpreted by the firmware. The scripts are written in a dedicated area of the GUI and can be debugged before downloading them onto the board. Once downloaded, the board can execute the scripts without requiring the use of PC software.

The LED1202 is a 12-channel low quiescent current LED driver; it guarantees 5 V output driving capability and each channel is able to provide up to 20 mA with a headroom voltage of 350 mV (typ.) only. The output current can be adjusted separately for each channel by 8-bit analog and 12-bit digital dimming control.

Product summary	
96 LEDs Panel Evaluation Board based on LED1202	STEVAL-LLL015V1
Firmware for STEVAL-LLL015V1 evaluation board for 8 LED1202 implementation	STSW-LLL015FW
GUI for LED1202 LED driver evaluation boards	STSW-LED1202GUI
12-Channel Low Quiescent Current LED Driver	LED1202QTR
Applications	LED lighting system

1 Schematic diagrams

Figure 1. STEVAL-LLL015M1 schematic diagram (1 of 3)

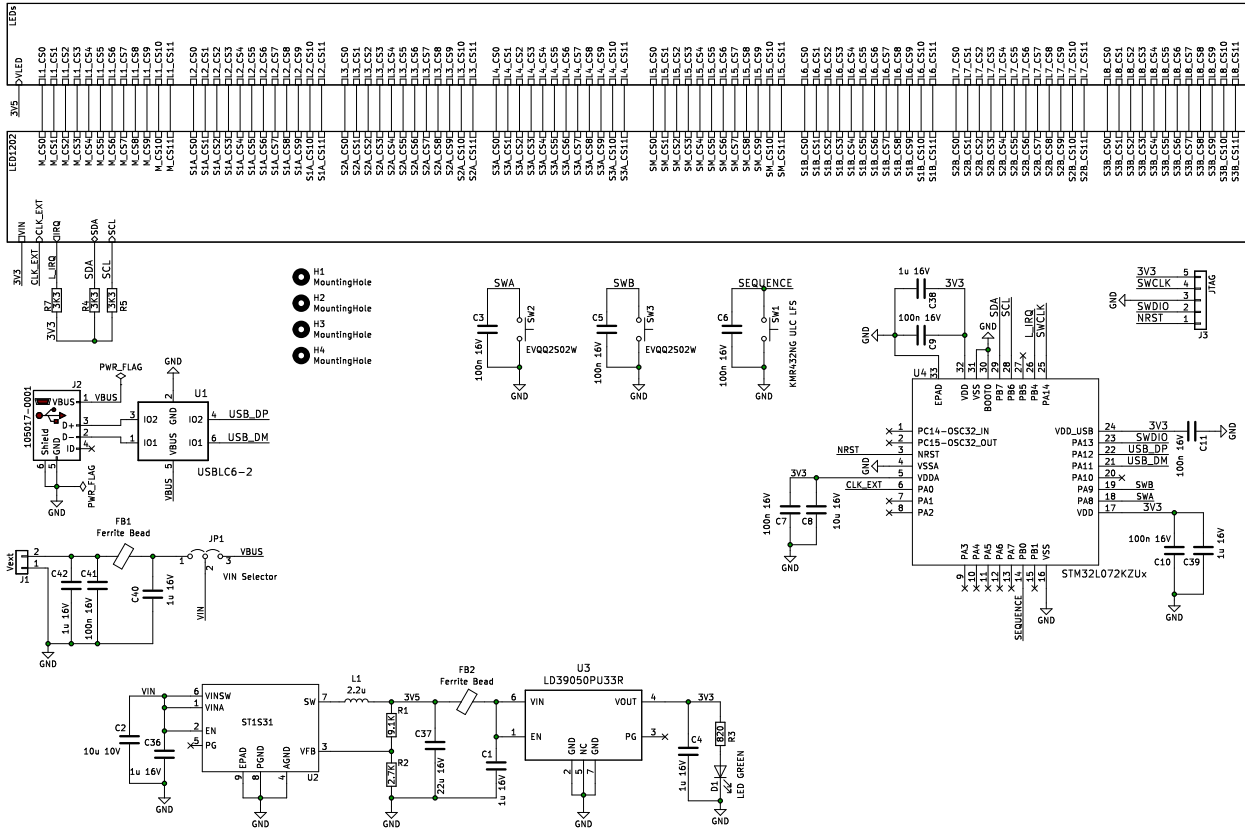

Figure 2. STEVAL-LLL015D1 schematic diagram (2 of 3)

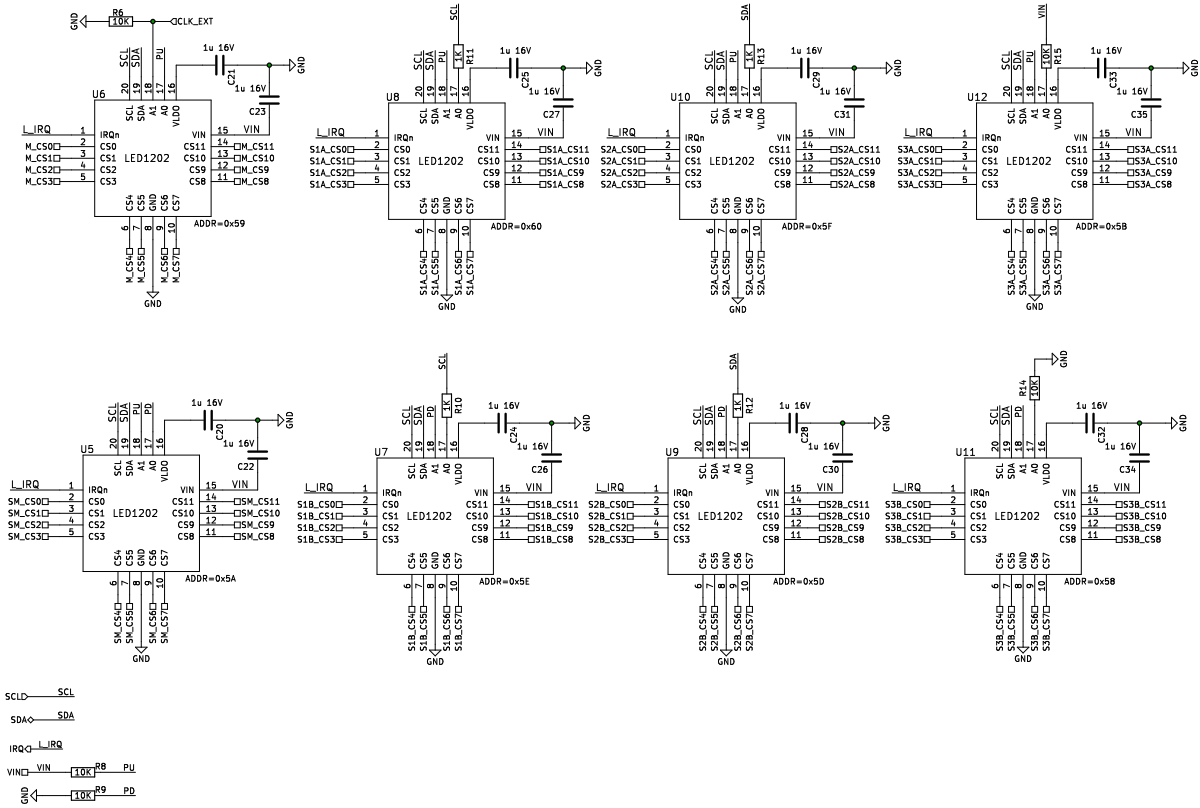
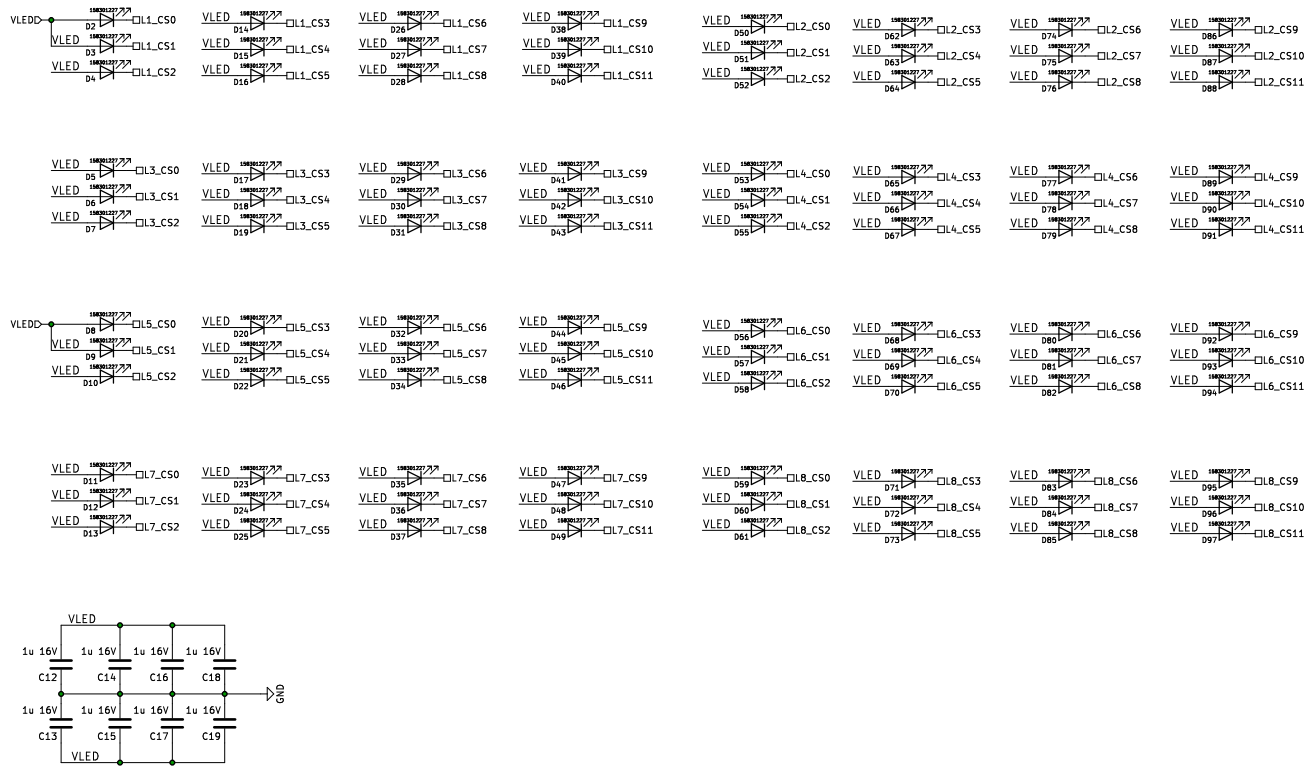

Figure 3. STEVAL-LLL015D1 schematic diagram (3 of 3)



2 Board versions

Table 1. STEVAL-LLL015V1 versions

PCB version	Schematic diagrams	Bill of materials
STEVAL\$LLL015V1A ⁽¹⁾	STEVAL\$LLL015V1A schematic diagrams	STEVAL\$LLL015V1A bill of materials

1. This code identifies the STEVAL-LLL015V1 evaluation board first version. It is printed on the board PCB.

Revision history

Table 2. Document revision history

Date	Revision	Changes
21-Oct-2024	1	Initial release.

IMPORTANT NOTICE – READ CAREFULLY

STMicroelectronics NV and its subsidiaries (“ST”) reserve the right to make changes, corrections, enhancements, modifications, and improvements to ST products and/or to this document at any time without notice. Purchasers should obtain the latest relevant information on ST products before placing orders. ST products are sold pursuant to ST’s terms and conditions of sale in place at the time of order acknowledgment.

Purchasers are solely responsible for the choice, selection, and use of ST products and ST assumes no liability for application assistance or the design of purchasers’ products.

No license, express or implied, to any intellectual property right is granted by ST herein.

Resale of ST products with provisions different from the information set forth herein shall void any warranty granted by ST for such product.

ST and the ST logo are trademarks of ST. For additional information about ST trademarks, refer to www.st.com/trademarks. All other product or service names are the property of their respective owners.

Information in this document supersedes and replaces information previously supplied in any prior versions of this document.

© 2024 STMicroelectronics – All rights reserved

1024 USB-C INPUT

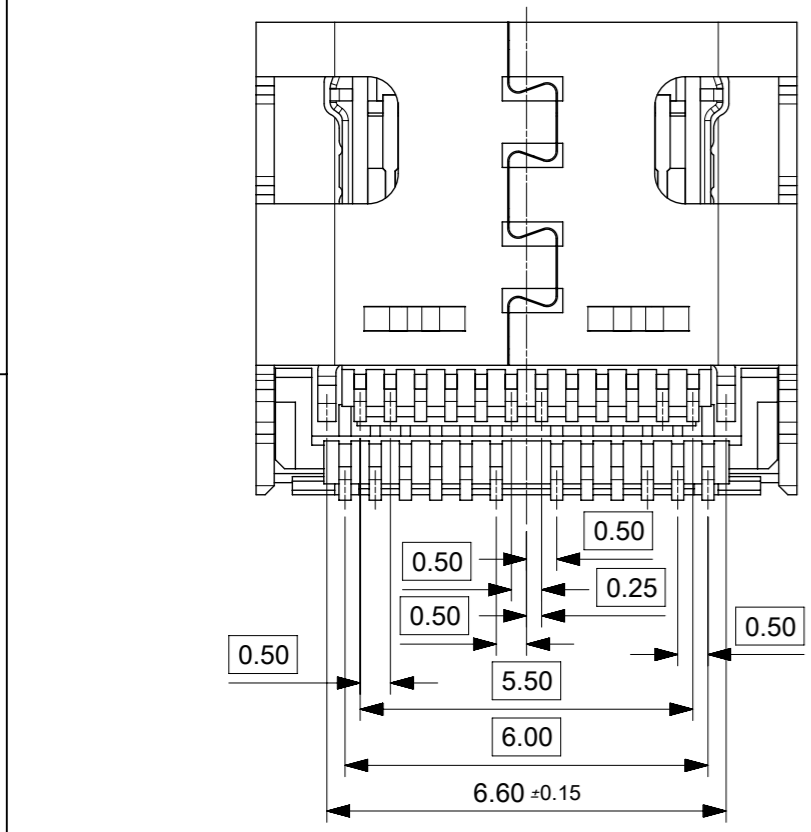
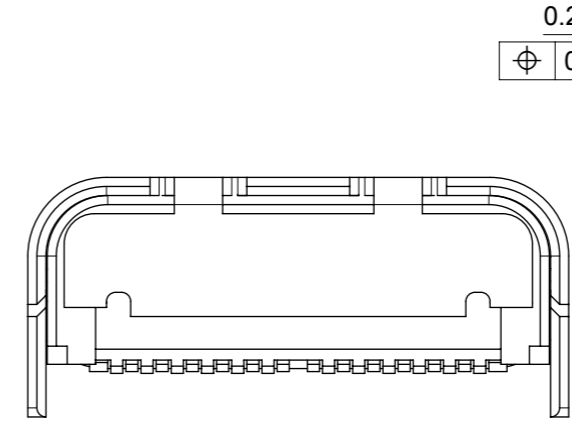
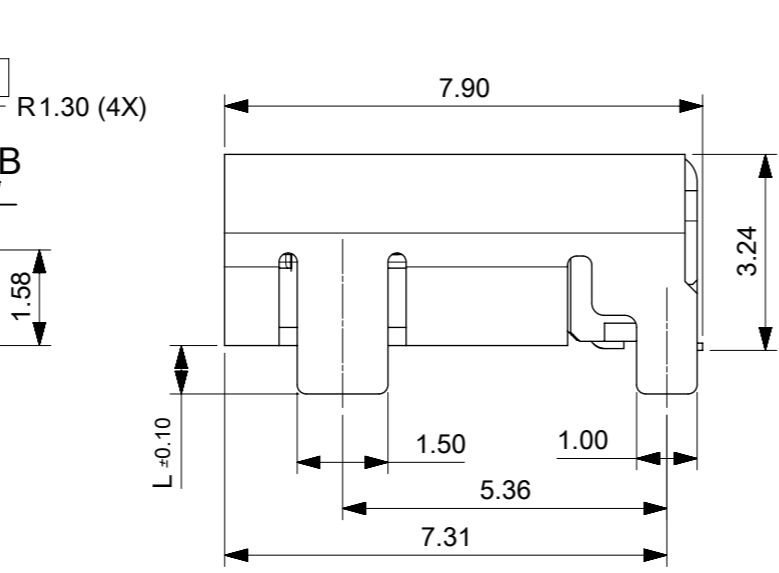
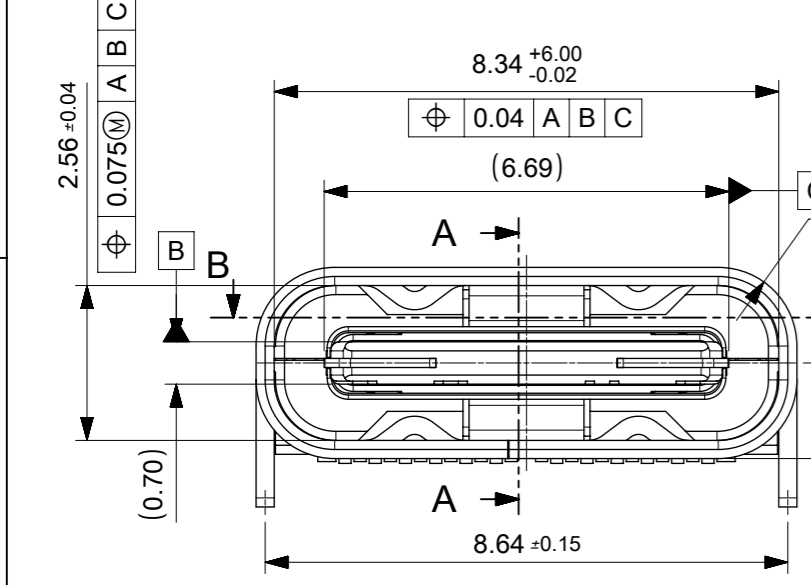
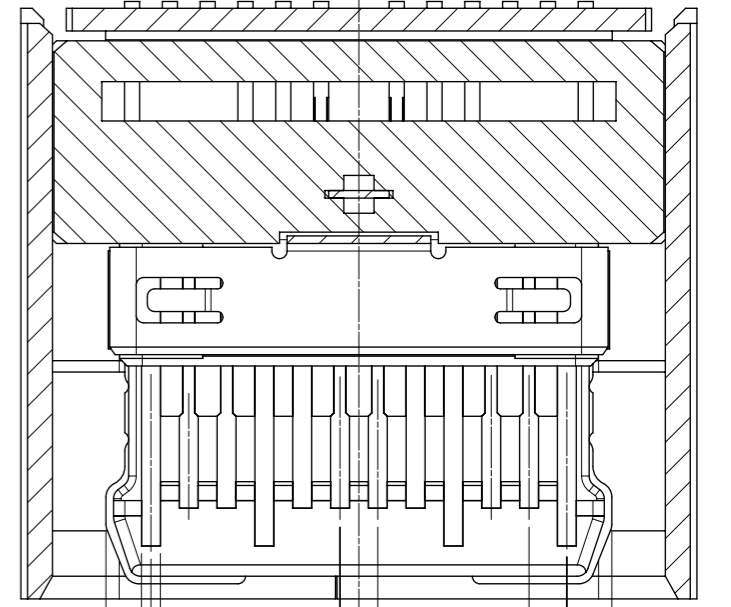
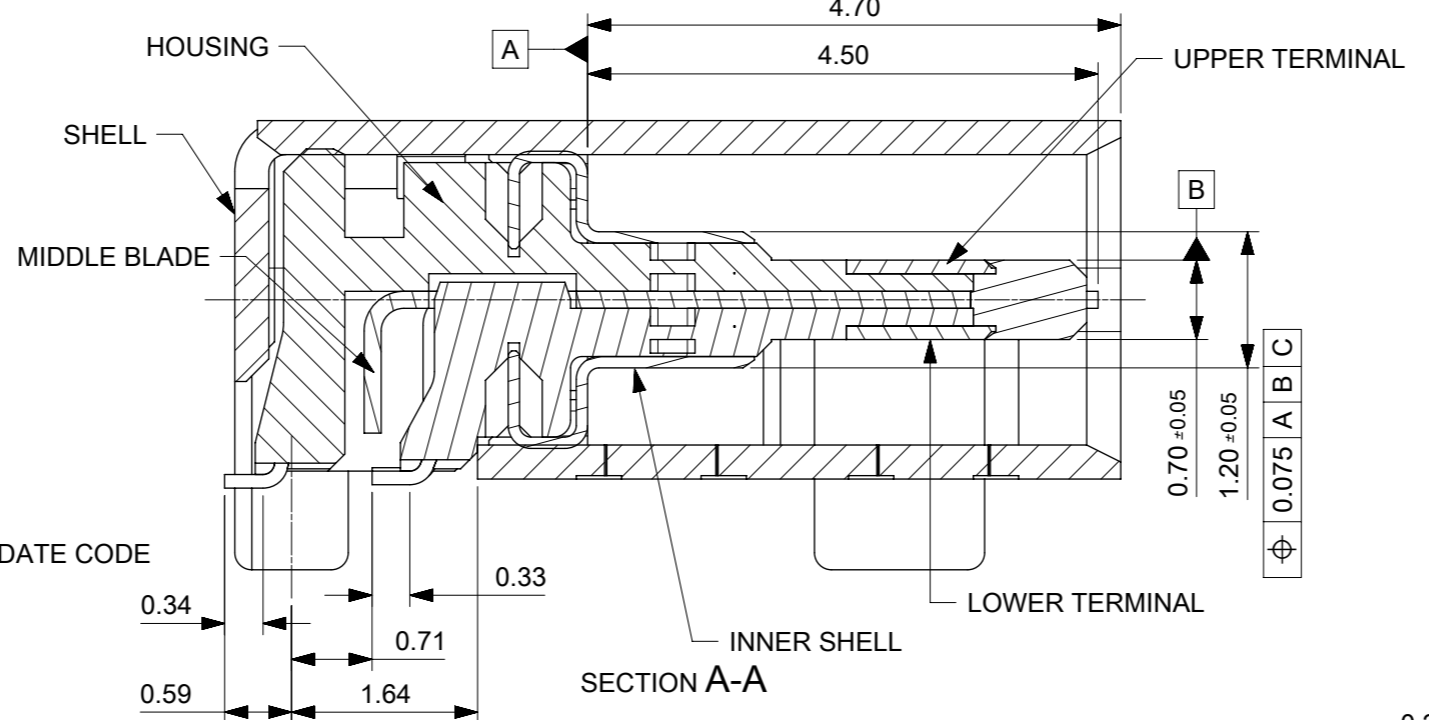
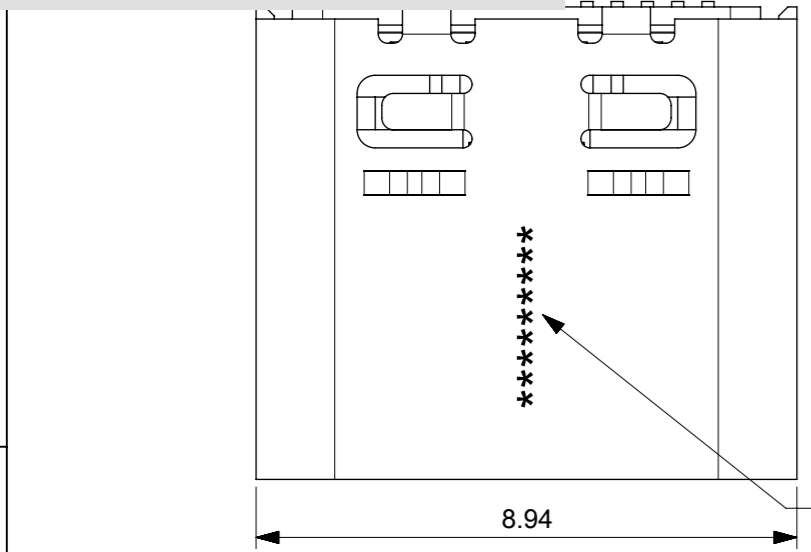

PART NO.	DESCRIPTION	L	PACKAGE
105450001	SEE NOTES 2 (1) FOR CONTACT AREA PLATING	0.80	PK-105450-001
1054500101	SEE NOTES 2 (2) FOR CONTACT AREA PLATING	0.50	
1054500111	SEE NOTES 2 (2) FOR CONTACT AREA PLATING	1.30	1054506666
1054500121	SEE NOTES 2 (2) FOR CONTACT AREA PLATING	0.80	

THIS DRAWING CONTAINS INFORMATION THAT IS PROPRIETARY TO MOLEX ELECTRONIC TECHNOLOGIES, LLC AND SHOULD NOT BE USED WITHOUT WRITTEN PERMISSION

2016/12/02 2017/04/24	GENERAL TOLERANCES (UNLESS SPECIFIED)	DIMENSION UNITS	SCALE	molex [®]		
		MM	7:1			
		DRWN BY	DATE		USB C TYPE REC TOP MOUNT SMT TAIL	
		RZHANG	2015/04/20			
EC NO: 115587 DRWN: RZHANG CHK'D: APPR: AYIN	DRAFT WHERE APPLICABLE MUST REMAIN WITHIN DIMENSIONS	ANGULAR TOL ± 3.0 °		PRODUCT CUSTOMER DRAWING		
		4 PLACES ±				
		3 PLACES ±		SERIES	MATERIAL NUMBER	CUSTOMER
		2 PLACES ± 0.2		105450	SEE CHART	GENERAL MARKET
1 PLACE ± 0.2		APPR BY	DATE			
0 PLACES ±		AYIN	2015/04/20			
		DRAWING SIZE	THIRD ANGLE PROJECTION	DOCUMENT NUMBER		
		A3		SD-105450-001		
				DOC TYPE		
				PSD		
				DOC PART		
				000		
				SHEET NUMBER		
				1 OF 2		

RELEASE STATUS	RELEASE DATE
----------------	--------------

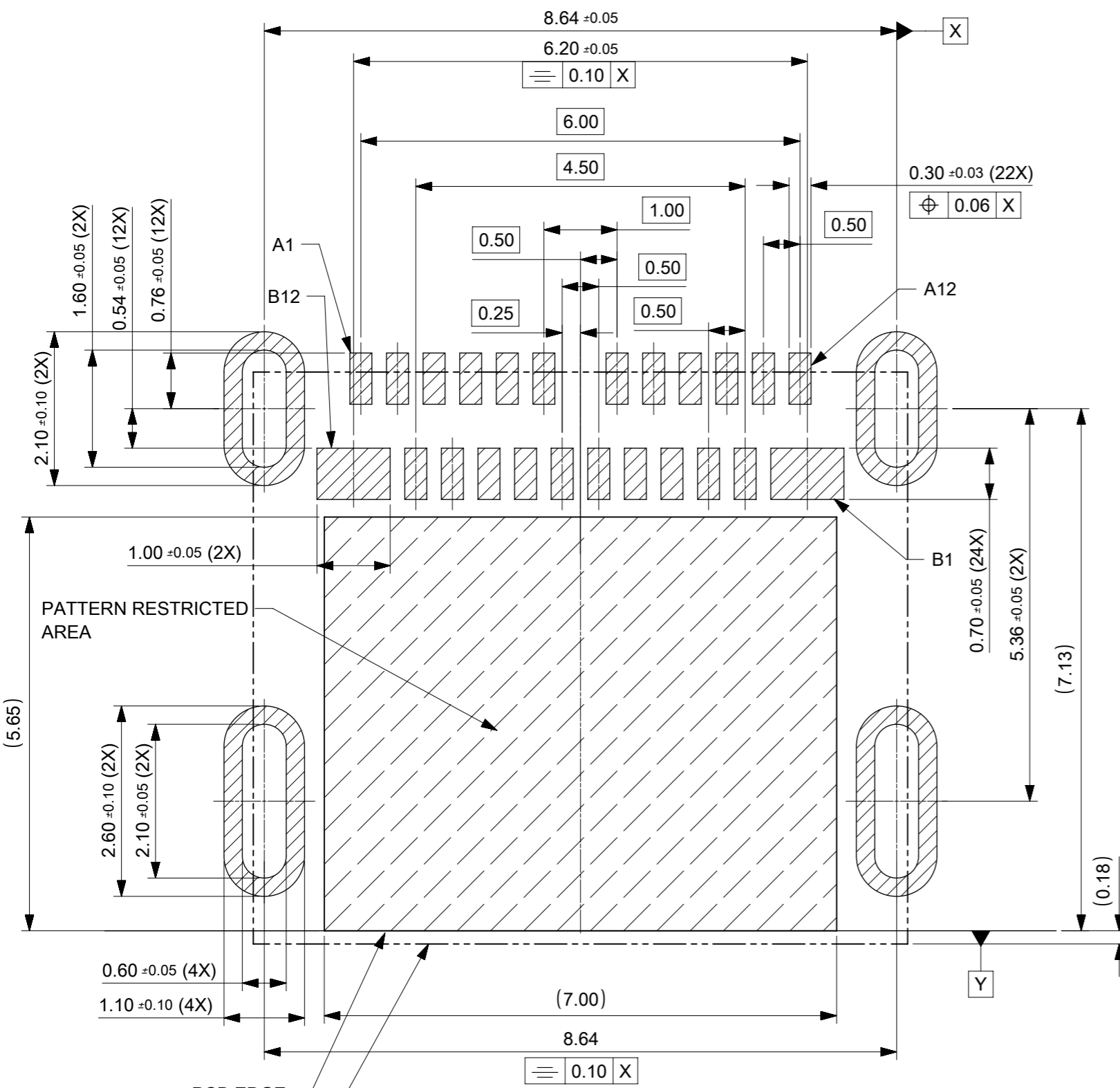

- NOTES:
- MATERIAL,
 HOUSING: HIGH TEMPERATURE THERMAL PLASTIC , 30% GLASS FILLED, BLACK, UL94V-0.
 TERMINAL: COPPER ALLOY
 SHELL: STAINLESS STEEL
 INNER SHELL: STAINLESS STEEL
 MIDDLE BLADE: STAINLESS STEEL
 - PLATING:
 TERMINAL: CONTACT AREA:
 (1). 0.76 MICROMETER MIN. GOLD PLATING
 (2). GOLD FLASH OVER 0.76 MICROMETER MIN. PALLADIUM/NICKEL PLATING
 AND SOLDER TAIL: 0.05 MICROMETER MIN. GOLD PLATING
 UNDER PLATING: 2 MICROMETER MIN. NICKEL PLATING OVERALL
 SHELL: 1 MICROMETER MIN. SOLDERABLE NICKEL PLATING OVERALL
 INNER SHELL: CLEANING
 MIDDLE BLADE: 2 MICROMETER MIN. TIN PLATING OVER THE SOLDER TAIL
 AND 1 MICROMETER NICKEL PLATING OVERALL
 - PRODUCT SPEC REFER TO PS-105448-001
 - COPLANARITY OF SMT PINS SOLDER TAIL IS 0.10 MAX. BEFORE AND AFTER REFLOW
 - T/H SOLDER TAIL POSITION BE CONTROLLED BY GAUGE
 - PRODUCT COMPLANT TO ROHS DIERTIVE 2011/65/EU AND ELV DIRECTIVE 2000/53/EC

PIN ASSIGNMENT											
A1	A2	A3	A4	A5	A6	A7	A8	A9	A10	A11	A12
GND	TX1+	TX1-	VBUS	CC1	D+	D-	SBU1	VBUS	RX2-	RX2+	GND
GND	RX1+	RX1-	VBUS	SBU2	D-	D+	CC2	VBUS	TX2-	TX2+	GND
B12	B11	B10	B9	B8	B7	B6	B5	B4	B3	B2	B1

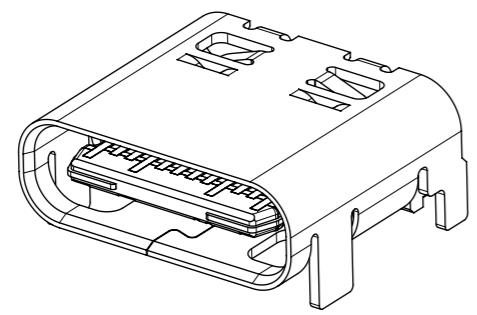

THIS DRAWING CONTAINS INFORMATION THAT IS PROPRIETARY TO MOLEX ELECTRONIC TECHNOLOGIES, LLC AND SHOULD NOT BE USED WITHOUT WRITTEN PERMISSION

EC NO: 115587 DRWN: RZHANG CHK'D: APPR: AYIN	2016/12/02	2017/04/24	GENERAL TOLERANCES (UNLESS SPECIFIED)		DIMENSION UNITS	SCALE		
			ANGULAR TOL ± 3.0 °		MM			
			4 PLACES ±	RZHANG		DATE		2015/04/20
			3 PLACES ±	CHK'D BY		DATE		
			2 PLACES ± 0.2	APPR BY		DATE		2015/04/20
		1 PLACE ± 0.2	DRAWING SIZE		THIRD ANGLE PROJECTION			
		0 PLACES ±	A3					
DRAFT WHERE APPLICABLE MUST REMAIN WITHIN DIMENSIONS								

PRODUCT CUSTOMER DRAWING			
SERIES	MATERIAL NUMBER	CUSTOMER	
105450	SEE SHEET 1	GENERAL MARKET	
DOCUMENT NUMBER	DOC TYPE	DOC PART	SHEET NUMBER
SD-105450-001	PSD	000	2 OF 2



2A Synchronous Buck Li-ion Charger

General Description

The LP28300 is a 2A Li-Ion battery charger. It utilizes a 500KHz synchronous buck converter topology to reduce power dissipation during charging. Low power dissipation, an internal MOSFET allow a physically small charger that can be embedded in a wide range of handheld applications. The LP28300 includes complete charge termination circuitry, automatic recharge.

Battery charge current, charge timeout and end-of-charge indication parameters are set with external components. Additional features include shorted cell detection; temperature qualified charging and overvoltage protection. The LP28300 is available in a low profile ESOP8/TDFN-10 3*3mm and package.

Order Information

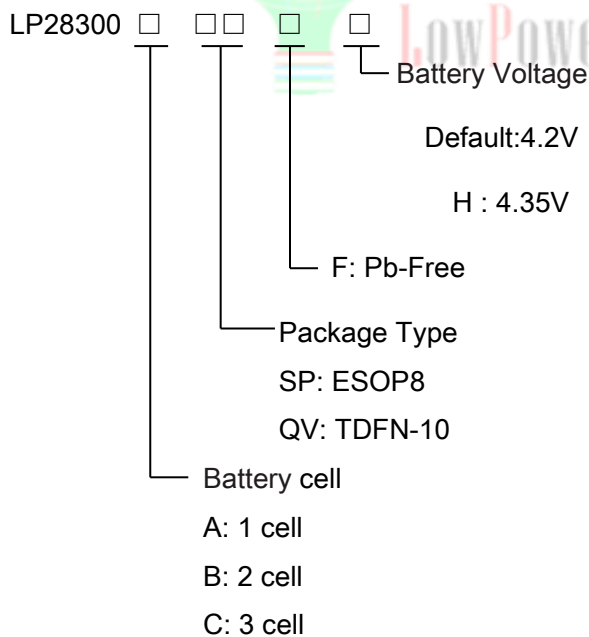

Features

- ◆ Input voltage range 4V~18V
- ◆ Dynamic input current allocation for maximum charging rate
- ◆ 2.0A Maximum Charge Current
- ◆ No External MOSFETs and Blocking Diode Required
- ◆ Efficiency up to 90%
- ◆ Constant-Current/Constant-Voltage Operation with Thermal Regulation to Maximize Charge Rate Without Risk of Overheating
- ◆ Optional Battery Temperature Monitoring Before and During Charge Automatic Sleep Mode for Low-Power
- ◆ Over Current Protection
- ◆ Consumption Available in ESOP8/TDFN-10
- ◆ RoHS Compliant and 100% Lead (Pb)-Free

Applications

- ✧ Portable Media Players
- ✧ Cellular and Smart mobile phone
- ✧ PDA/DSC
- ✧ Handheld Battery-Powered Devices
- ✧ Handheld Computers
- ✧ Charging Docks and Cradles



Marking Information

Device	Marking	Package	Shipping	Device	Marking	Package	Shipping
LP28300ASPF	LPS	ESOP8	4K/REEL	LP28300BSPF	LPS	ESOP8	4K/REEL
LP28300AQVF	LP28300A YWX	TDFN-10	5K/REEL	LP28300BQVF	LP28300B YWX	TDFN-10	5K/REEL
LP28300ASPFH	LPS	ESOP8	4K/REEL	LP28300CSPF	LPS	ESOP8	4K/REEL
LP28300AQVFH	LP28300AH YWX	TDFN-10	5K/REEL	LP28300CQVF	LP28300C YWX	TDFN-10	5K/REEL

Marking indication:

Y: Year code. W: Week code. X: Batch numbers.

Typical Application Circuit

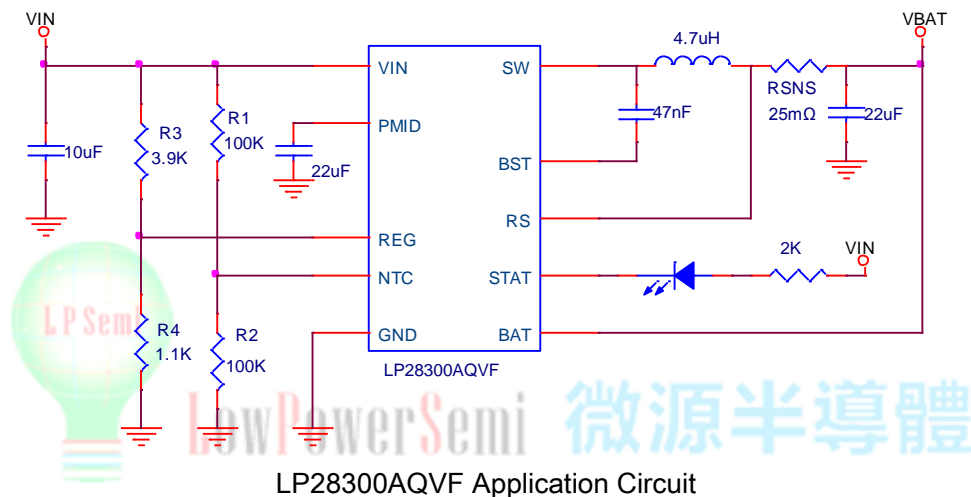

LP28300AQVF Application Circuit

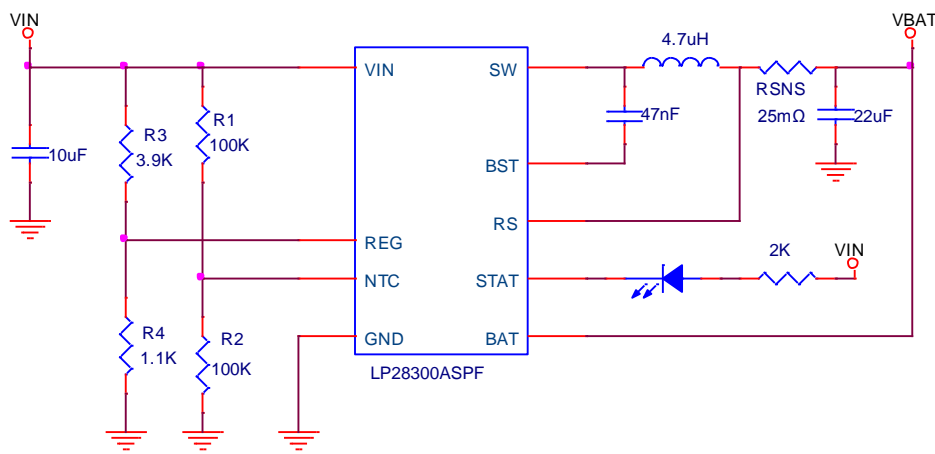

LP28300ASPF Application Circuit



Functional Pin Description

Package Type	Pin Configurations
ESOP8 / TDFN-10	

Pin Description

Pin		Name	Description
ESOP8	TDFN-10		
SW	1	4	Switch pin. Connect to external inductor.
BST	2	8	Internal charge pump boost pin.
STAT	3	7	Open-Drain Charge Status Output. When the battery is charging, this pin is pulled low by an internal N-channel MOSFET. When the LP28300 detects an under voltage lockout condition, STAT is forced high impedance.
NTC	4	6	NTC (Negative Temperature Coefficient) Thermistor Input. This pin senses the temperature of the battery pack and stops the charger when the temperature is out of range. Connect to GND for disabling this function.
BAT	5	9	Battery pin.
RS	6	10	Detecting pin of charge current.
REG	7	1	Input voltage feedback for the input voltage regulation loop. Connect to tap of an external resistor divider from VIN to GND to program the input voltage regulation. Once the voltage at REG pin drops to the inner threshold, the charge current is reduced to maintain the input voltage at the regulation value.
VIN	8	2	Positive Supply Voltage Input. Decouple with a 10µF or larger surface mounted ceramic capacitor.
GND	Pad	5,11	Ground.
PMID		3	Power MOS input pin. Connect a 22uF Capacitor to ground.



Absolute Maximum Ratings ^{Note 1}

◇ VIN /PMID /BST/NTC to GND	24V
◇ REG Voltage to GND	6.5V
◇ BAT Pin to GND	20V
◇ Maximum Junction Temperature	150°C
◇ Operating Ambient Temperature Range (T _A)	-40°C to 85°C
◇ Maximum Soldering Temperature (at leads, 10 sec)	260°C

Note 1. Stresses beyond those listed under “Absolute Maximum Ratings” may cause permanent damage to the device. These are stress ratings only, and functional operation of the device at these or any other conditions beyond those indicated in the operational sections of the specifications is not implied. Exposure to absolute maximum rating conditions for extended periods may affect device reliability.

Thermal Information

◇ Maximum Power Dissipation (ESOP8, P _D , T _A =25°C)	2W
◇ Thermal Resistance (ESOP8, θ _{JA})	50°C/W
◇ Maximum Power Dissipation (TDFN-10, P _D , T _A =25°C)	1.5W
◇ Thermal Resistance (TDFN-10, θ _{JA})	65°C/W

ESD Susceptibility

◇ HBM(Human Body Mode)	2KV
◇ MM(Machine Mode)	200V

Recommended Operating Conditions

◇ Operating Junction Temperature Range (T _J)	-40°C to 150°C
◇ Ambient Temperature Range	-40°C to 85°C



Electrical Characteristics

(The specifications which apply over the full operating temperature range, otherwise specifications are at $T_A=25^{\circ}\text{C}$, $V_{\text{IN}} = 5\text{V}$, unless otherwise noted.)

Symbol	Parameter	Condition	Min	Typ	Max	Units
V_{IN}	Adapter/USB Voltage Range		4		18	V
I_{CC}	Input Supply Current	Standby Mode (Charge Terminated)		1		mA
V_{FLOAT}	Regulated Output (Float) Voltage	LP28300AQVF/SPF	4.158	4.2	4.242	V
		LP28300AQVF/SPFH	4.306	4.35	4.395	
		LP28300BQVF/SPF		8.4		V
		LP28300CQVF/SPF		12.6		V
V_{RS}	Program Charging Current (For RS to BAT)	$V_{\text{TRIKL}} < V_{\text{BAT}} < V_{\text{FLOAT}}$		50		mV
I_{BAT}	BAT Pin Current	$R_{\text{SNS}}=50\text{m}\Omega$, Current Mode		1000		mA
		$R_{\text{SNS}}=25\text{m}\Omega$, Current Mode		2000		mA
		Standby Mode		4		μA
I_{TRIKL}	Trickle Charge Current	$V_{\text{BAT}} < V_{\text{TRIKL}}$, $R_{\text{SNS}}=50\text{m}\Omega$		100		mA
		$V_{\text{BAT}} < 2.3\text{V}$		20		mA
V_{TRIKL}	Trickle Charge Threshold Voltage	$R_{\text{SNS}}=50\text{m}\Omega$, V_{BAT} Rising		2.8		V
V_{TRHYS}	Trickle Charge Hysteresis Voltage	$R_{\text{SNS}}=50\text{m}\Omega$		100		mV
V_{REG}	Input voltage regulation reference			1		V
V_{STAT}	STAT Pin Output Low Voltage	$I_{\text{STAT}}=5\text{mA}$			0.5	V
ΔV_{RECHRG}	Recharge Battery Threshold Voltage	$V_{\text{FLOAT}} - V_{\text{RECHRG}}$		150		mV
T_{LIM}	Junction Temperature in Constant Temperature Mode			150		$^{\circ}\text{C}$
I_{TERM}	C/10 Terminal Current	$R_{\text{SNS}}=50\text{m}\Omega$		100		mA
UVLO	Under Voltage Lockout of V_{IN}	V_{IN} rising		4.1		V
		V_{IN} falling		3.9		V
$V_{\text{NTC-H}}$	Threshold Voltage of V_{NTC} rising			70		$\%V_{\text{IN}}$
$V_{\text{NTC-L}}$	Threshold Voltage of V_{NTC} falling			30		$\%V_{\text{IN}}$
F_{OSC}	Frequency			500		KHz



Typical Operating Characteristics

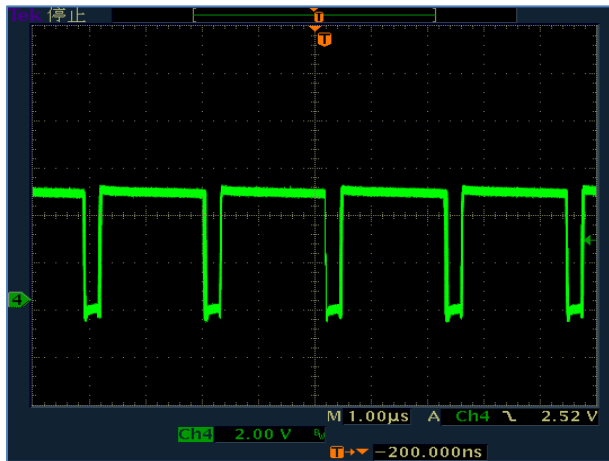
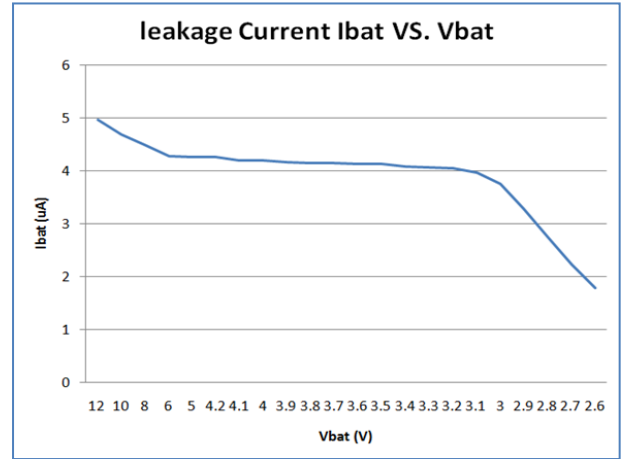
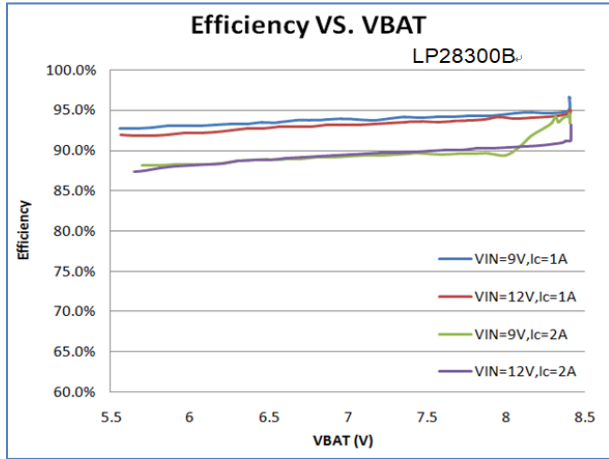

LP28300A, I_{BAT}=2A, CH4=V_{SW}, V_{IN}=5V

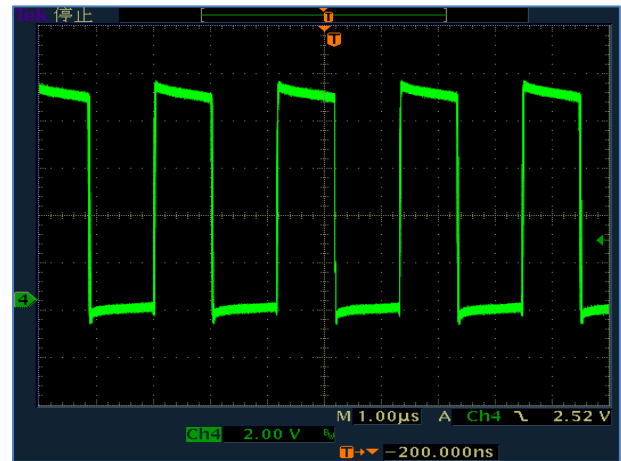

LP28300A, I_{BAT}=2A, CH4=V_{SW}, V_{IN}=9V

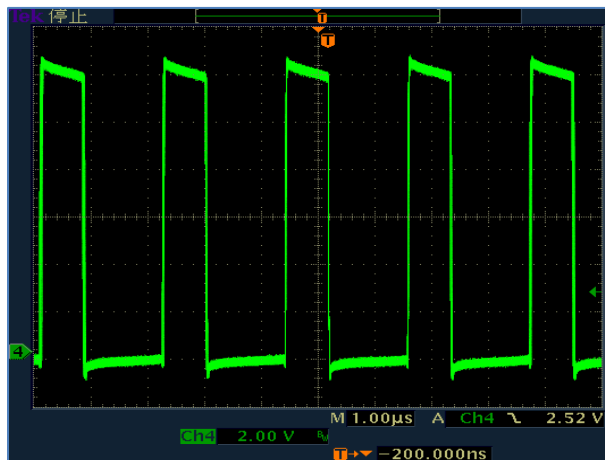

LP28300A, I_{BAT}=2A, CH4=V_{SW}, V_{IN}=12V



Application Information

LP28300 is a wide range $V_{IN}(4V-18V)$, 2A 1/2/3-cells synchronous buck Li-Ion battery charger integrates 500KHz switching frequency and full protection functions. The charge current up to 2A can be programmed by using the external resistor for different portable applications and indicates the charger current information simultaneous.

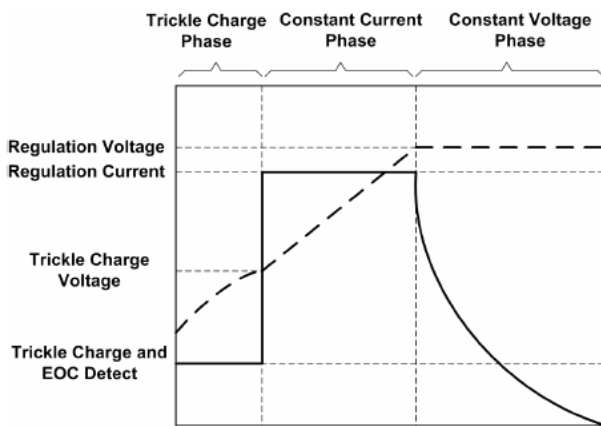

Figure 1. Typical Charge Profile

In constant current mode, the charge current is set by the external sense resistor R_{SNS} and an internal 50mV reference;

$$I_{BAT} = V_{RS} / R_{SNS} = 50mV / R_{SNS}$$

When the battery voltage approaches the programmed float voltage, the charge current will start to decrease. When the current drops to 10% of the full-scale charge current, an internal comparator turns off charging is terminated

Input Source Qualification

After R_{EGN} amplifier powers up, the LP28300 checks the current capability of the input source. The input source has to meet the $V_{REG} > 1V$ to enable the chip.

Shutdown

The LP28300 can be shut down by pulling the NTC pin to V_{IN} . When the NTC pin is released, the internal timer is reset and a new charge cycle starts. In shutdown, the output of the STAT pin is high impedance. Removing the input power supply will put the charger into sleep mode. If the voltage at the V_{IN} pin drops below $(V_{BAT} + 200mV)$ or below the UVLO level, the LP28300 goes into a low current sleep mode, reducing the battery drain current.

Automatic Recharge

Once the charge cycle is terminated, the LP28300 continuously monitors the voltage on the BAT pin using a comparator with a 1.8ms filter time ($t_{RECHARGE}$). A charge cycle restarts when the battery voltage falls below 4.05V (which corresponds to approximately 80% to 90% battery capacity). This ensures that the battery is kept at or near a fully charged condition and eliminates the need for periodic charge cycle initiations.

Battery Temperature Detection

The LP28300 continuously monitors temperature by measuring the voltage between the NTC and GND pins. A negative or a positive temperature coefficient thermistor (NTC, PTC) and an external voltage divider typically develop this voltage. The LP28300 compares this voltage against its internal V_{NTC1} and V_{NTC2} thresholds to determine if charging is allowed. The temperature sensing circuit is immune to any fluctuation in V_{IN} , since both the external voltage divider and the internal thresholds (V_{NTC1} and V_{NTC2}) are referenced to V_{IN} .



The resistor values of R_1 and R_2 are calculated by the following equations:

For NTC Thermistors:

$$R_1 = \frac{R_{TL}R_{TH}(K_2 - K_1)}{(R_{TL} - R_{TH})K_1K_2}$$
$$R_2 = \frac{R_{TL}R_{TH}(K_2 - K_1)}{R_{TL}(K_1 - K_1K_2) - R_{TH}(K_2 - K_1K_2)}$$

For PTC Thermistors:

$$R_1 = \frac{R_{TL}R_{TH}(K_2 - K_1)}{(R_{TH} - R_{TL})K_1K_2}$$
$$R_2 = \frac{R_{TL}R_{TH}(K_2 - K_1)}{R_{TH}(K_1 - K_1K_2) - R_{TL}(K_2 - K_1K_2)}$$

$K_{1(V_{NTC1})}=30\%$, $K_{2(V_{NTC2})}=70\%$.

Where R_{TL} is the low temperature resistance and R_{TH} is the high temperature resistance of thermistor, as specified by the thermistor manufacturer. R_1 or R_2 can be omitted if only one temperature (low or high) setting is required. Applying a voltage between the V_{NTC1} and V_{NTC2} thresholds to pin NTC disables the temperature-sensing feature.

Inductor Selection

A operating frequency was chosen for the buck switcher in order to minimize the size of the inductor. However, take care to use inductors with low core loss at this frequency. To calculate the inductor ripple current:

$$\Delta I_L = \frac{V_{BAT} - \frac{V_{BAT}^2}{V_{IN}}}{L \times f}$$

Layout Considerations

Switch rise and fall times are kept under 5ns for maximum efficiency. To minimize radiation, the SW pin and input bypass capacitor leads (between VIN and GND) should be kept as short as possible. A ground plane should be used under the switching circuitry to prevent inter plane coupling. The Exposed Pad must be connected to the ground plane for proper power dissipation. The other paths contain only DC and/or 500KHz tri-wave ripple current and are less critical. With the exception of the input and output filter capacitors (which should be connected to GND) all other components that return to ground should be connected to GND.



Packaging Information

ESOP8

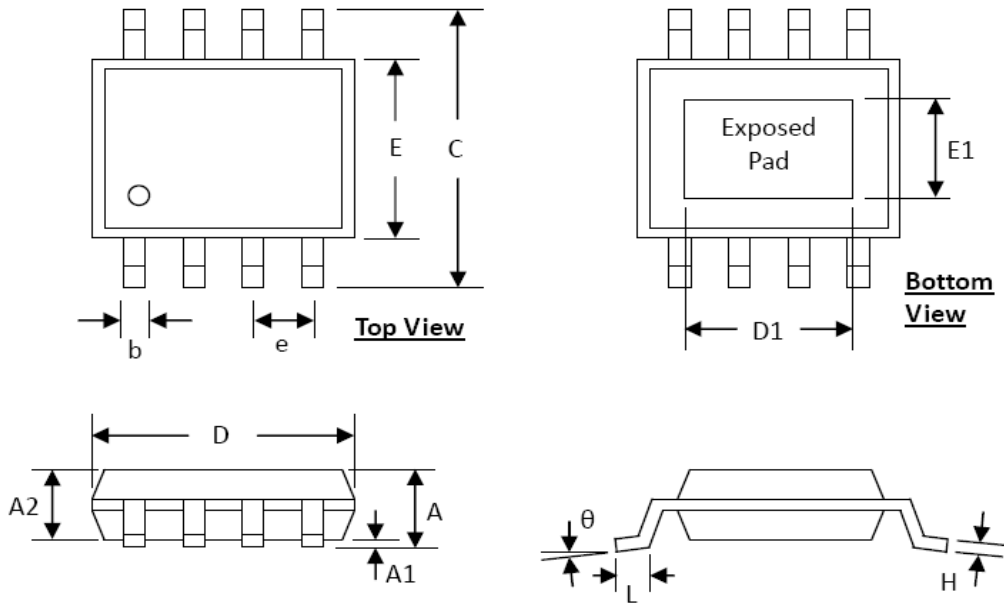

SYMBOLS	DIMENSION (MM)		DIMENSION (INCH)	
	MIN	MAX	MIN	MAX
A	1.30	1.70	0.051	0.067
A1	0.00	0.15	0.000	0.006
A2	1.25	1.52	0.049	0.060
b	0.33	0.51	0.013	0.020
C	5.80	6.20	0.228	0.244
D	4.80	5.00	0.189	0.197
D1	3.15	3.45	0.124	0.136
E	3.80	4.00	0.150	0.157
E1	2.26	2.56	0.089	0.101
e	1.27 BSC		0.050 BSC	
H	0.19	0.25	0.0075	0.0098
L	0.41	1.27	0.016	0.050
θ	0°	8°	0°	8°



TDFN-10

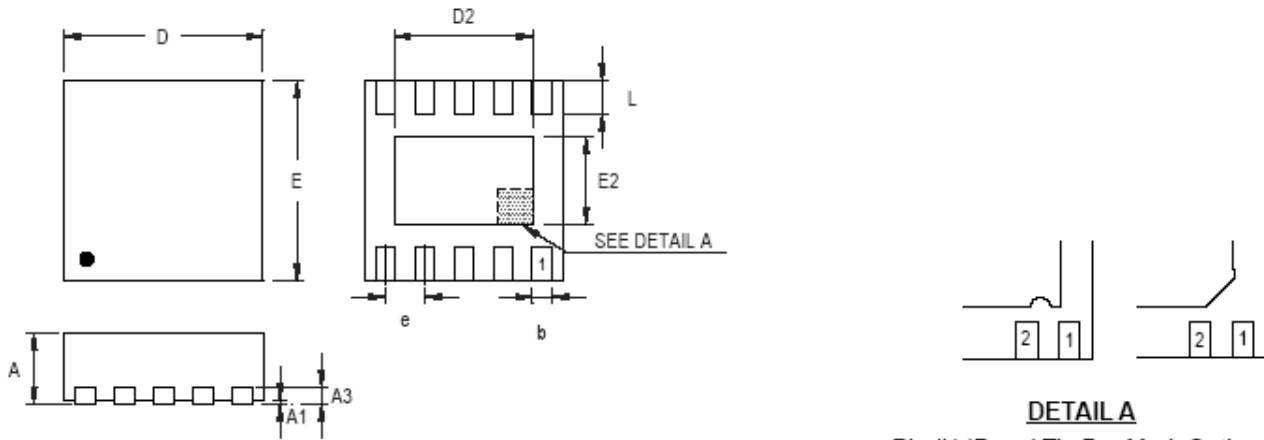

DETAIL A

Pin #1 ID and Tie Bar Mark Options

Note : The configuration of the Pin #1 identifier is optional, but must be located within the zone indicated.

Symbol	Dimensions In Millimeters		Dimensions In Inches	
	Min	Max	Min	Max
A	0.700	0.800	0.028	0.031
A1	0.000	0.050	0.000	0.002
A3	0.175	0.250	0.007	0.010
b	0.180	0.300	0.007	0.012
D	2.950	3.050	0.116	0.120
D2	2.300	2.650	0.091	0.104
E	2.950	3.050	0.116	0.120
E2	1.500	1.750	0.059	0.069
e	0.500		0.020	
L	0.350	0.450	0.014	0.018

W-Type 10L DFN 3x3 Package

Shock Sensor (Impact Sensor) IC

BD3852MUZ-Z

General Description

BD3852MUZ-Z is connected with an external shock sensor. It is equipped with a function to amplify the shock detection signal from the shock sensor and transmit the amplified signal externally.

It delivers high S/N characteristics and is ideal for control system applications such as HDD processing.

Features

- Operating Power Supply Voltage Range: 1.6 V to 2.3 V, Single Power Supply Operation
- Freely Tunable Frequency Characteristics and the Gain according to Applications
- Built-in Notch Filter for Reducing the Effect of the Shock Sensor Resonance Point (fo: 31 kHz)

Applications

- HDD/light Pick-up Shock Detection and Write Protection
- HDD/light Pick-up Inertial Force Fluctuation Feed Forward Control

Key Specifications

- Recommended Operating Power Supply Voltage Range: 1.6 V to 2.3 V
- Notch Frequency: 31 kHz (Typ)
- Notch Attenuation Rate: -23 dB (Max)
- Current Consumption: 3.9 mA (Typ)
- Recommended Operating Temperature Range: -40 °C to +85 °C

Package

VQFN16Z3030A

W (Typ) x D (Typ) x H (Max)

3.0 mm x 3.0 mm x 0.4 mm

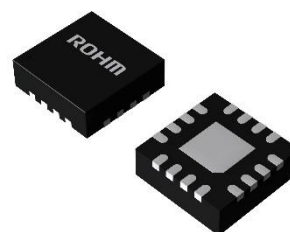

Typical Application Circuit

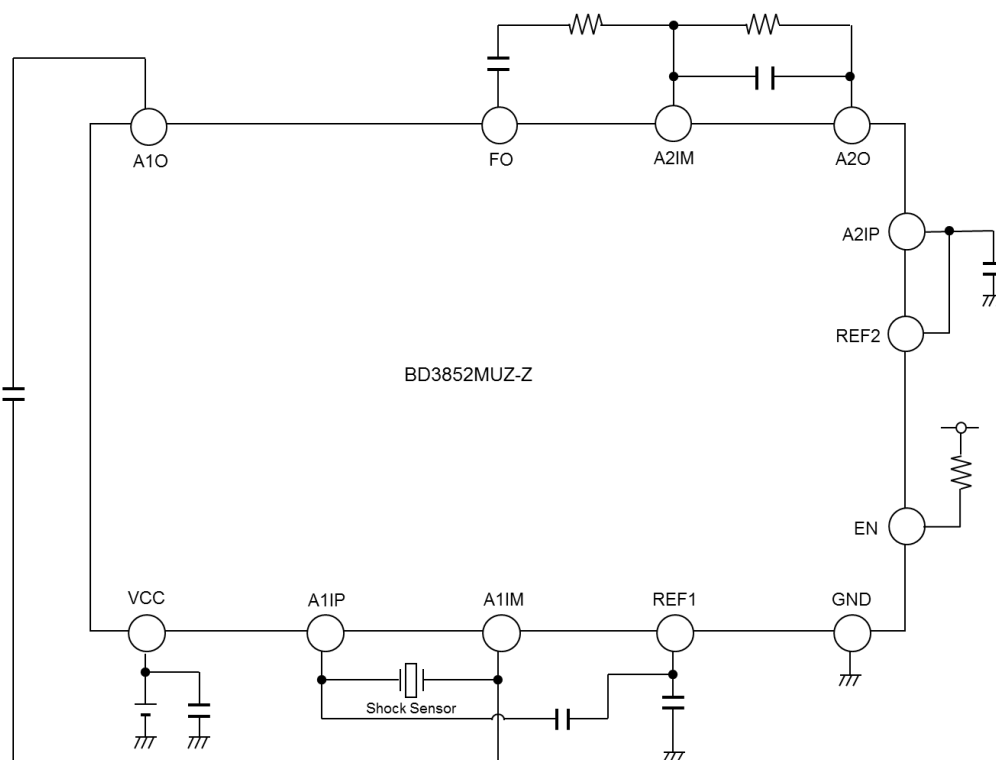

○Product structure : Silicon integrated circuit ○This product has no designed protection against radioactive rays.

Pin Configuration

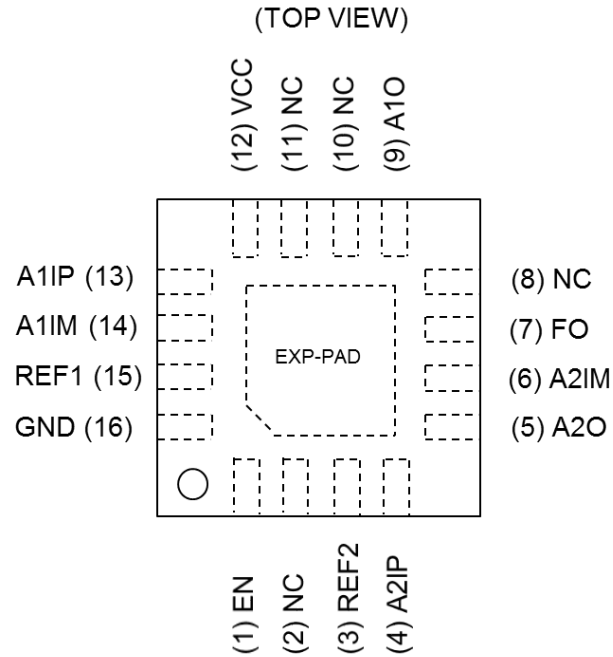

Pin Description

Pin No.	Pin Name	Function
1	EN	Enable input pin (H input: Power ON, L input: Power saving) Pull-down at 50 kΩ inside the IC
2	NC	Connect to the GND pin
3	REF2	Reference output pin (0.8 V)
4	A2IP	OP-AMP2 non-inverting input pin
5	A2O	OP-AMP2 output pin
6	A2IM	OP-AMP2 inverting input pin
7	FO	Filter output pin
8	NC	Connect to the GND pin
9	A1O	OP-AMP1 output pin
10	NC	Connect to the GND pin
11	NC	Connect to the GND pin
12	VCC	Power supply voltage pin
13	A1IP	OP-AMP1 non-inverting input pin
14	A1IM	OP-AMP1 inverting input pin
15	REF1	Reference output pin (0.4 V)
16	GND	Ground pin
-	EXP-PAD	The EXP-PAD connect to the GND pin

Block Diagram

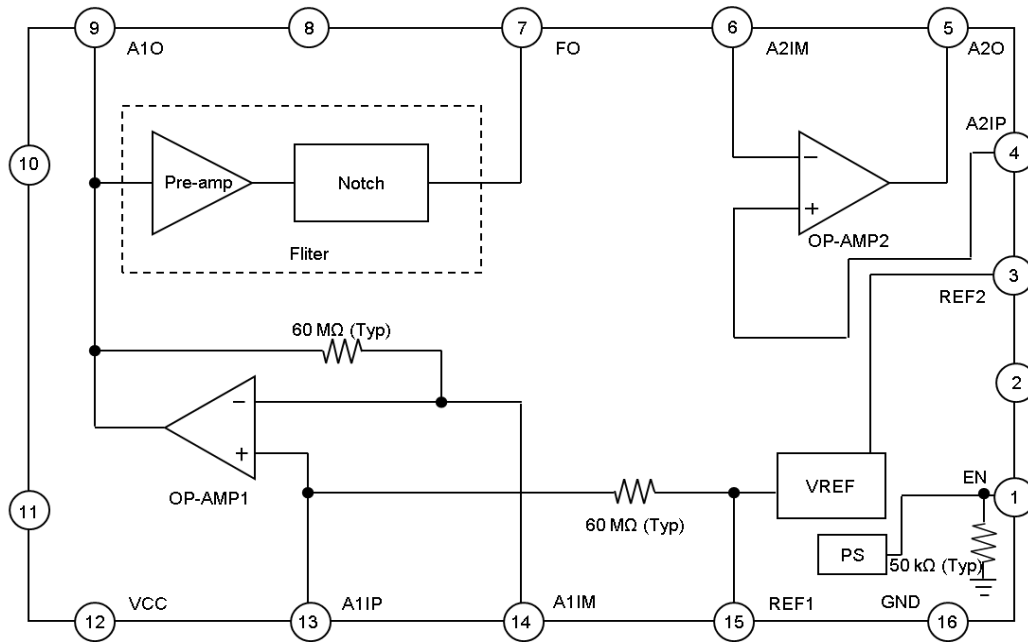

Description of Blocks

OP-AMP1: Detects the charge signal generated in the shock sensor by the charge amplifier configuration.

Filter: Amplifies by 13.9 dB with the preamplifier, and attenuates the f_0 component of the shock sensor resonance frequency (Typ: 31 kHz) with the notch filter.

OP-AMP2: Serves as the amplifier for the signal amplification and the filter. (The gain is configurable using add-on R and C.)

VREF: Generates the REF1 and REF2 output voltages.

PS: Switches between the power saving and power ON states according to the EN pin input voltage.

Absolute Maximum Ratings

Parameter	Symbol	Rating	Unit
Power Supply Voltage	V_{CC}	4.5	V
Input Voltage	$V_{A1IM}, V_{A1IP}, V_{A2IM}, V_{A2IP}, V_{EN}$	-0.3 to $V_{CC} + 0.3$	V
Output Voltage	$V_{A1O}, V_{A2O}, V_{FO}, V_{REF1}, V_{REF2}$	-0.3 to $V_{CC} + 0.3$	V
Maximum Junction Temperature	T_{jmax}	150	°C
Storage Temperature	T_{stg}	-55 to +150	°C

Caution 1: Operating the IC over the absolute maximum ratings may damage the IC. The damage can either be a short circuit between pins or an open circuit between pins and the internal circuitry. Therefore, it is important to consider circuit protection measures, such as adding a fuse, in case the IC is operated over the absolute maximum ratings.

Caution 2: Should by any chance the maximum junction temperature rating be exceeded the rise in temperature of the chip may result in deterioration of the properties of the chip. In case of exceeding this absolute maximum rating, design a PCB with power dissipation taken into consideration by increasing board size and copper area so as not to exceed the maximum junction temperature rating.

Power Dissipation

Parameter	Symbol	Rating	Unit
Power Dissipation ^(Note 1)	P_d	3.00	W

(Note 1) When a 114.3 mm x 76.2 mm x 1.6 mm glass epoxy substrate (JEDEC substrate) is mounted. Reduced at 24.9 mW/°C in $T_a > 25$ °C.

Recommended Operating Conditions

Parameter	Symbol	Operating Range			Unit
		Min	Typ	Max	
Power Supply Voltage	V_{CC}	1.6	1.8	2.3	V
Operating Temperature	T_{opr}	-40	+25	+85	°C

(Note 2) A short circuit between the adjacent pins, reverse connection, rotated connection, short circuit with the power supply, ground fault, and so on may destroy the IC. Since an overload voltage or overload current may be applied to peripheral components, pay sufficient attention during the design and installation.

Electrical Characteristics ($V_{CC} = 1.8\text{ V}$, $T_a = 25\text{ }^\circ\text{C}$ unless otherwise specified.)

Parameter	Symbol	Standard Values			Unit	Conditions
		Min	Typ	Max		
Current Consumption	I_{CC}	1.6	3.9	4.5	mA	H input to the EN pin
	I_{CCPS}	-	-	10	μA	L input to the EN pin

1. EN Pin

Parameter	Symbol	Standard Values			Unit	Conditions
		Min	Typ	Max		
Input Voltage	V_{IH1}	$V_{CC} \times 0.7$	-	$V_{CC} + 0.3$	V	
	V_{IL1}	-0.3	-	$V_{CC} \times 0.3$	V	
Built-in Pull-down Resistance	R_{UD}	35	50	65	$\text{k}\Omega$	

2. OP-AMP Characteristics

(1) OP-AMP1

Parameter	Symbol	Standard Values			Unit	Conditions
		Min	Typ	Max		
Output DC Voltage	V_{DC1}	0.3	0.4	0.5	V	With no signal
Output Load Fluctuations (Source)	$V_{SOURCE1}$	-100	-	-	mV	Difference between the output DC voltage with no load and the output DC voltage when $80\text{ }\mu\text{A}$ is subtracted
Output Load Fluctuations (Sink)	V_{SINK1}	-	-	+100	mV	Difference between the output DC voltage with no load and the output DC voltage when $80\text{ }\mu\text{A}$ is added

(2) OP-AMP2

Parameter	Symbol	Standard Values			Unit	Conditions
		Min	Typ	Max		
Input Current	I_{IN}	-50	-	+50	nA	
Output DC Voltage 1	V_{DC21}	0.67	0.80	0.93	V	When the A2IP and REF2 pins are connected
Output DC Voltage 2	V_{DC22}	0.75	0.80	0.85	V	When 0.8 V is input to the A2IP pin
Output Voltage Range (L side)	V_{OL2}	-	-	0.3	V	
Output Voltage Range (H side)	V_{OH2}	$V_{CC} - 0.3$	-	-	V	
Output Source Current	I_{ASO2}	80	-	-	μA	Current flowing into the A2O pin when $V_{CC} - 0.3\text{ V}$ is applied to the A2O pin
Output Sink Current	I_{ASI2}	80	-	-	μA	Current flowing out of the A2O pin when 0.3 V is applied to the A2O pin

2. OP-AMP Characteristics – continued

(3) Filter

Parameter	Symbol	Standard Values			Unit	Conditions
		Min	Typ	Max		
Output DC Voltage	V_{DC3}	200	400	600	mV	
Output Load Fluctuations (Source)	$V_{SOURCE3}$	-100	-	-	mV	Difference between the output DC voltage with no load and the output DC voltage when 80 μ A is subtracted
Output Load Fluctuations (Sink)	V_{SINK3}	-	-	+100	mV	Difference between the output DC voltage with no load and the output DC voltage when 80 μ A is added
Voltage Gain	G_V	-	13.9	-	dB	
Notch Attenuation Rate	ATT	-	-	-23	dB	Attenuation rate at $f_o = 31$ kHz when the signal amplitude of the A1O pin is 5 mVpp

(4) VREF

Parameter	Symbol	Standard Values			Unit	Conditions
		Min	Typ	Max		
REF1 Output Voltage	V_{REF1}	0.35	0.40	0.45	V	With no load
REF2 Output Voltage	V_{REF2}	0.68	0.80	0.92	V	With no load
REF2 Output Load Fluctuations (Source)	V_{REF2SO}	-100	-	-	mV	Difference in the output DC voltages with no load and when 80 μ A is subtracted
REF2 Output Load Fluctuations (Sink)	V_{REF2SI}	-	-	+100	mV	Difference in the output DC voltages with no load and when 80 μ A is added

Reference Data (Note 3)

(Note 3) No shipping test is performed for the reference data.

1. OP-AMP1

Parameter	Symbol	Standard Values			Unit	Conditions
		Min	Typ	Max		
Input Bias Voltage	V_{IN}	-	0.4	-	V	With no signal
Input Impedance	Z_{IN}	-	60	-	M Ω	
GBW (Cut-off Frequency)	f_{T1}	-	1.5	-	MHz	

2. OP-AMP2

Parameter	Symbol	Standard Values			Unit	Conditions
		Min	Typ	Max		
GBW (Cut-off Frequency)	f_{T2}	-	1.5	-	MHz	

3. Filter

Parameter	Symbol	Standard Values			Unit	Conditions
		Min	Typ	Max		
Notch Frequency	f_o	-	31	-	kHz	When the signal amplitude of the A1O pin is 5 mVpp

Reference Data – continued

4. Specifications of the EN Pin at Startup and during Power Saving

Parameter	Symbol	Standard Values			Unit	Conditions
		Min	Typ	Max		
Shutdown Time	t_{SD}	-	6	10	μs	Time elapsed after the EN pin input is changed from H to L until the REF2 output voltage is decreased to 10 % of V_{REF2} or less
Startup Time	t_{SU}	-	10	50	ms	Time elapsed after the EN pin input is changed from H to L until the REF2 output voltage is increased to 90 % of V_{REF2} or more

Application Example

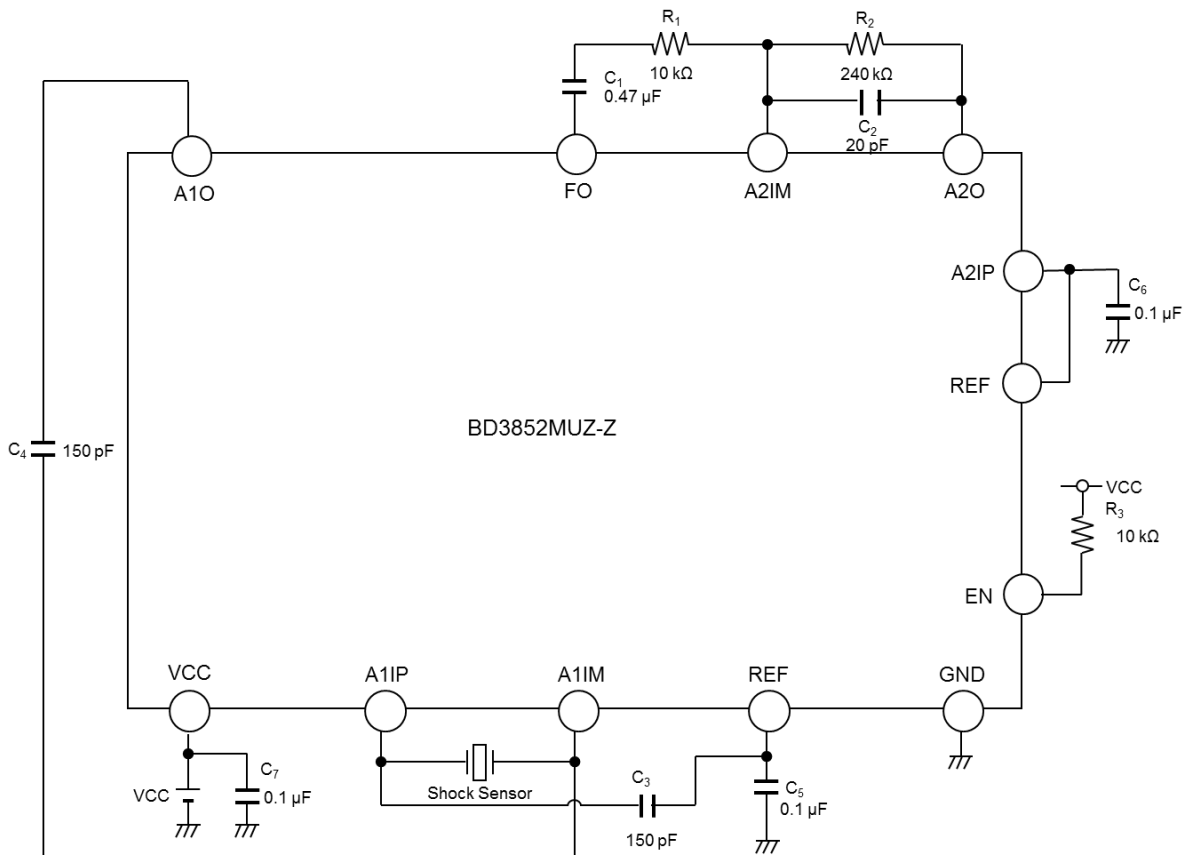

I/O Equivalence Circuits

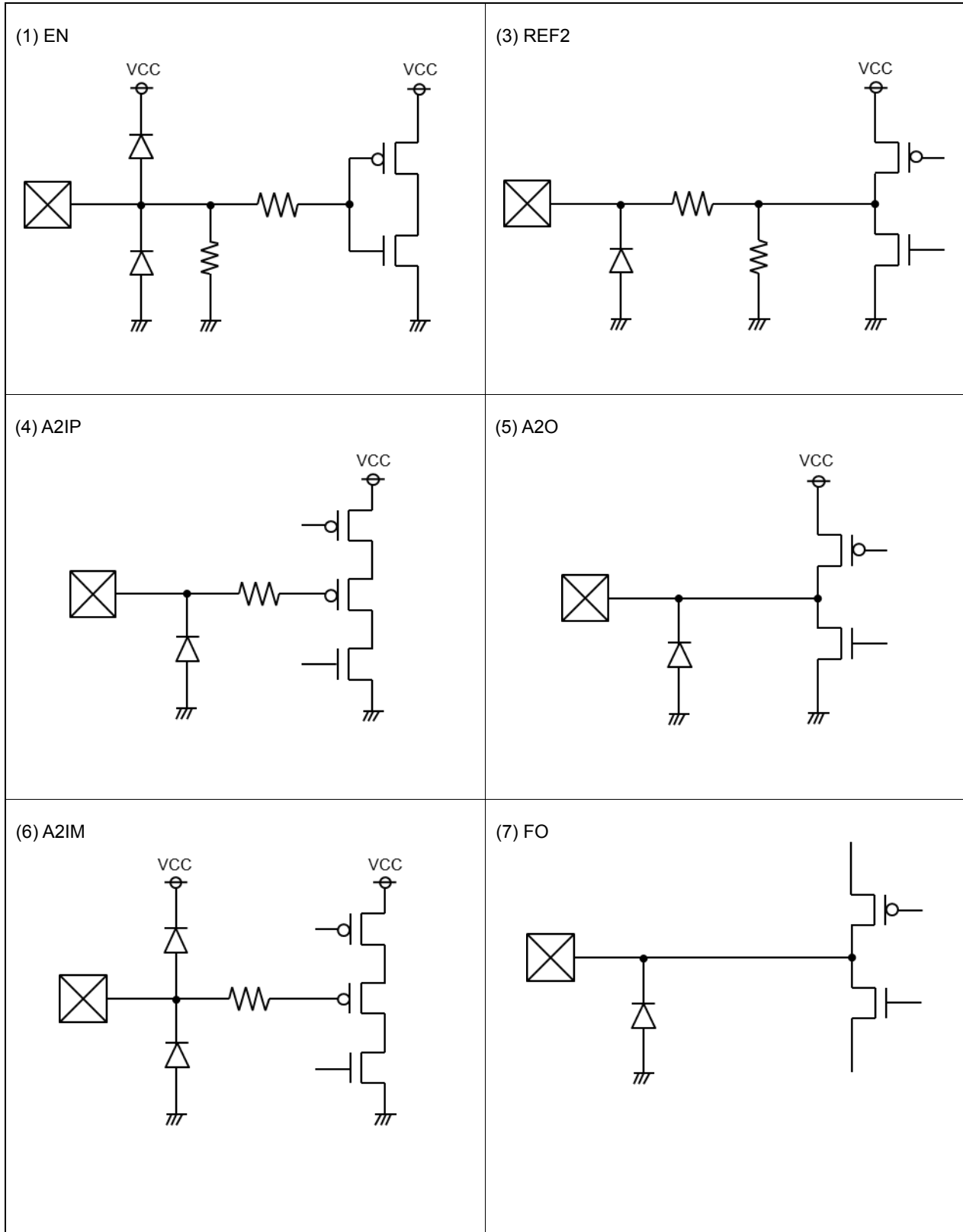

I/O Equivalence Circuits – continued

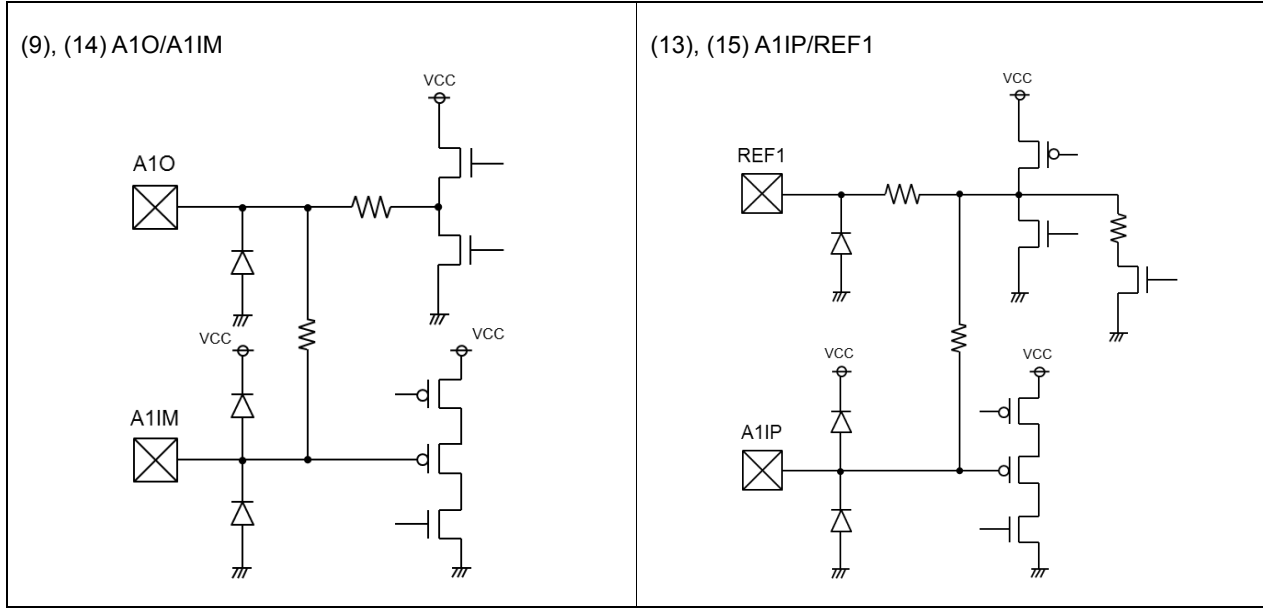

Operational Notes

1. Reverse Connection of Power Supply

Connecting the power supply in reverse polarity can damage the IC. Take precautions against reverse polarity when connecting the power supply, such as mounting an external diode between the power supply and the IC's power supply pins.

2. Power Supply Lines

Design the PCB layout pattern to provide low impedance supply lines. Furthermore, connect a capacitor to ground at all power supply pins. Consider the effect of temperature and aging on the capacitance value when using electrolytic capacitors.

3. Ground Voltage

Ensure that no pins are at a voltage below that of the ground pin at any time, even during transient condition.

4. Ground Wiring Pattern

When using both small-signal and large-current ground traces, the two ground traces should be routed separately but connected to a single ground at the reference point of the application board to avoid fluctuations in the small-signal ground caused by large currents. Also ensure that the ground traces of external components do not cause variations on the ground voltage. The ground lines must be as short and thick as possible to reduce line impedance.

5. Recommended Operating Conditions

The function and operation of the IC are guaranteed within the range specified by the recommended operating conditions. The characteristic values are guaranteed only under the conditions of each item specified by the electrical characteristics.

6. Inrush Current

When power is first supplied to the IC, it is possible that the internal logic may be unstable and inrush current may flow instantaneously due to the internal powering sequence and delays, especially if the IC has more than one power supply. Therefore, give special consideration to power coupling capacitance, power wiring, width of ground wiring, and routing of connections.

7. Testing on Application Boards

When testing the IC on an application board, connecting a capacitor directly to a low-impedance output pin may subject the IC to stress. Always discharge capacitors completely after each process or step. The IC's power supply should always be turned off completely before connecting or removing it from the test setup during the inspection process. To prevent damage from static discharge, ground the IC during assembly and use similar precautions during transport and storage.

Operational Notes – continued

8. Inter-pin Short and Mounting Errors

Ensure that the direction and position are correct when mounting the IC on the PCB. Incorrect mounting may result in damaging the IC. Avoid nearby pins being shorted to each other especially to ground, power supply and output pin. Inter-pin shorts could be due to many reasons such as metal particles, water droplets (in very humid environment) and unintentional solder bridge deposited in between pins during assembly to name a few.

9. Unused Input Pins

Input pins of an IC are often connected to the gate of a MOS transistor. The gate has extremely high impedance and extremely low capacitance. If left unconnected, the electric field from the outside can easily charge it. The small charge acquired in this way is enough to produce a significant effect on the conduction through the transistor and cause unexpected operation of the IC. So unless otherwise specified, unused input pins should be connected to the power supply or ground line.

10. Regarding the Input Pin of the IC

This monolithic IC contains P+ isolation and P substrate layers between adjacent elements in order to keep them isolated. P-N junctions are formed at the intersection of the P layers with the N layers of other elements, creating a parasitic diode or transistor. For example (refer to figure below):

When $GND > Pin A$ and $GND > Pin B$, the P-N junction operates as a parasitic diode.

When $GND > Pin B$, the P-N junction operates as a parasitic transistor.

Parasitic diodes inevitably occur in the structure of the IC. The operation of parasitic diodes can result in mutual interference among circuits, operational faults, or physical damage. Therefore, conditions that cause these diodes to operate, such as applying a voltage lower than the GND voltage to an input pin (and thus to the P substrate) should be avoided.

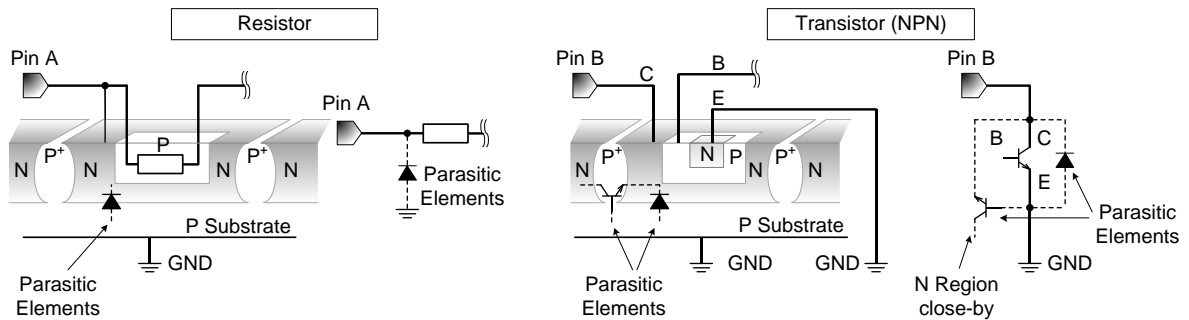

Example of Monolithic IC Structure

11. Ceramic Capacitor

When using a ceramic capacitor, determine a capacitance value considering the change of capacitance with temperature and the decrease in nominal capacitance due to DC bias and others.

Ordering Information

B D 3 8 5 2 M U Z - ZTR

Package
MUZ:
VQFN16Z3030A

Packaging and forming specification
TR: Embossed tape and reel

Marking Diagram

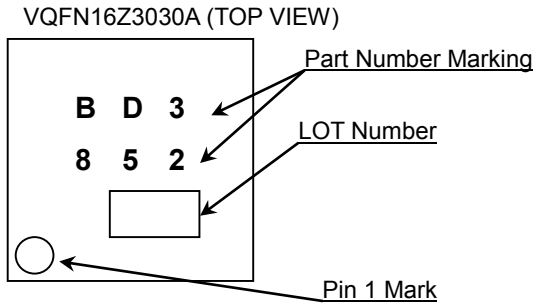

Revision History

Date	Revision	Changes
11.Mar.2020	001	New Release

Notice

Precaution on using ROHM Products

- Our Products are designed and manufactured for application in ordinary electronic equipment (such as AV equipment, OA equipment, telecommunication equipment, home electronic appliances, amusement equipment, etc.). If you intend to use our Products in devices requiring extremely high reliability (such as medical equipment ^(Note 1), transport equipment, traffic equipment, aircraft/spacecraft, nuclear power controllers, fuel controllers, car equipment including car accessories, safety devices, etc.) and whose malfunction or failure may cause loss of human life, bodily injury or serious damage to property ("Specific Applications"), please consult with the ROHM sales representative in advance. Unless otherwise agreed in writing by ROHM in advance, ROHM shall not be in any way responsible or liable for any damages, expenses or losses incurred by you or third parties arising from the use of any ROHM's Products for Specific Applications.

(Note1) Medical Equipment Classification of the Specific Applications

JAPAN	USA	EU	CHINA
CLASS III	CLASS III	CLASS II b	CLASS III
CLASS IV		CLASS III	

- ROHM designs and manufactures its Products subject to strict quality control system. However, semiconductor products can fail or malfunction at a certain rate. Please be sure to implement, at your own responsibilities, adequate safety measures including but not limited to fail-safe design against the physical injury, damage to any property, which a failure or malfunction of our Products may cause. The following are examples of safety measures:
 - Installation of protection circuits or other protective devices to improve system safety
 - Installation of redundant circuits to reduce the impact of single or multiple circuit failure
- Our Products are designed and manufactured for use under standard conditions and not under any special or extraordinary environments or conditions, as exemplified below. Accordingly, ROHM shall not be in any way responsible or liable for any damages, expenses or losses arising from the use of any ROHM's Products under any special or extraordinary environments or conditions. If you intend to use our Products under any special or extraordinary environments or conditions (as exemplified below), your independent verification and confirmation of product performance, reliability, etc. prior to use, must be necessary:
 - Use of our Products in any types of liquid, including water, oils, chemicals, and organic solvents
 - Use of our Products outdoors or in places where the Products are exposed to direct sunlight or dust
 - Use of our Products in places where the Products are exposed to sea wind or corrosive gases, including Cl₂, H₂S, NH₃, SO₂, and NO₂
 - Use of our Products in places where the Products are exposed to static electricity or electromagnetic waves
 - Use of our Products in proximity to heat-producing components, plastic cords, or other flammable items
 - Sealing or coating our Products with resin or other coating materials
 - Use of our Products without cleaning residue of flux (Exclude cases where no-clean type fluxes is used. However, recommend sufficiently about the residue.) ; or Washing our Products by using water or water-soluble cleaning agents for cleaning residue after soldering
 - Use of the Products in places subject to dew condensation
- The Products are not subject to radiation-proof design.
- Please verify and confirm characteristics of the final or mounted products in using the Products.
- In particular, if a transient load (a large amount of load applied in a short period of time, such as pulse, is applied, confirmation of performance characteristics after on-board mounting is strongly recommended. Avoid applying power exceeding normal rated power; exceeding the power rating under steady-state loading condition may negatively affect product performance and reliability.
- De-rate Power Dissipation depending on ambient temperature. When used in sealed area, confirm that it is the use in the range that does not exceed the maximum junction temperature.
- Confirm that operation temperature is within the specified range described in the product specification.
- ROHM shall not be in any way responsible or liable for failure induced under deviant condition from what is defined in this document.

Precaution for Mounting / Circuit board design

- When a highly active halogenous (chlorine, bromine, etc.) flux is used, the residue of flux may negatively affect product performance and reliability.
- In principle, the reflow soldering method must be used on a surface-mount products, the flow soldering method must be used on a through hole mount products. If the flow soldering method is preferred on a surface-mount products, please consult with the ROHM representative in advance.

For details, please refer to ROHM Mounting specification

Precautions Regarding Application Examples and External Circuits

1. If change is made to the constant of an external circuit, please allow a sufficient margin considering variations of the characteristics of the Products and external components, including transient characteristics, as well as static characteristics.
2. You agree that application notes, reference designs, and associated data and information contained in this document are presented only as guidance for Products use. Therefore, in case you use such information, you are solely responsible for it and you must exercise your own independent verification and judgment in the use of such information contained in this document. ROHM shall not be in any way responsible or liable for any damages, expenses or losses incurred by you or third parties arising from the use of such information.

Precaution for Electrostatic

This Product is electrostatic sensitive product, which may be damaged due to electrostatic discharge. Please take proper caution in your manufacturing process and storage so that voltage exceeding the Products maximum rating will not be applied to Products. Please take special care under dry condition (e.g. Grounding of human body / equipment / solder iron, isolation from charged objects, setting of Ionizer, friction prevention and temperature / humidity control).

Precaution for Storage / Transportation

1. Product performance and soldered connections may deteriorate if the Products are stored in the places where:
 - [a] the Products are exposed to sea winds or corrosive gases, including Cl₂, H₂S, NH₃, SO₂, and NO₂
 - [b] the temperature or humidity exceeds those recommended by ROHM
 - [c] the Products are exposed to direct sunshine or condensation
 - [d] the Products are exposed to high Electrostatic
2. Even under ROHM recommended storage condition, solderability of products out of recommended storage time period may be degraded. It is strongly recommended to confirm solderability before using Products of which storage time is exceeding the recommended storage time period.
3. Store / transport cartons in the correct direction, which is indicated on a carton with a symbol. Otherwise bent leads may occur due to excessive stress applied when dropping of a carton.
4. Use Products within the specified time after opening a humidity barrier bag. Baking is required before using Products of which storage time is exceeding the recommended storage time period.

Precaution for Product Label

A two-dimensional barcode printed on ROHM Products label is for ROHM's internal use only.

Precaution for Disposition

When disposing Products please dispose them properly using an authorized industry waste company.

Precaution for Foreign Exchange and Foreign Trade act

Since concerned goods might be fallen under listed items of export control prescribed by Foreign exchange and Foreign trade act, please consult with ROHM in case of export.

Precaution Regarding Intellectual Property Rights

1. All information and data including but not limited to application example contained in this document is for reference only. ROHM does not warrant that foregoing information or data will not infringe any intellectual property rights or any other rights of any third party regarding such information or data.
2. ROHM shall not have any obligations where the claims, actions or demands arising from the combination of the Products with other articles such as components, circuits, systems or external equipment (including software).
3. No license, expressly or implied, is granted hereby under any intellectual property rights or other rights of ROHM or any third parties with respect to the Products or the information contained in this document. Provided, however, that ROHM will not assert its intellectual property rights or other rights against you or your customers to the extent necessary to manufacture or sell products containing the Products, subject to the terms and conditions herein.

Other Precaution

1. This document may not be reprinted or reproduced, in whole or in part, without prior written consent of ROHM.
2. The Products may not be disassembled, converted, modified, reproduced or otherwise changed without prior written consent of ROHM.
3. In no event shall you use in any way whatsoever the Products and the related technical information contained in the Products or this document for any military purposes, including but not limited to, the development of mass-destruction weapons.
4. The proper names of companies or products described in this document are trademarks or registered trademarks of ROHM, its affiliated companies or third parties.

General Precaution

1. Before you use our Products, you are requested to carefully read this document and fully understand its contents. ROHM shall not be in any way responsible or liable for failure, malfunction or accident arising from the use of any ROHM's Products against warning, caution or note contained in this document.
2. All information contained in this document is current as of the issuing date and subject to change without any prior notice. Before purchasing or using ROHM's Products, please confirm the latest information with a ROHM sales representative.
3. The information contained in this document is provided on an "as is" basis and ROHM does not warrant that all information contained in this document is accurate and/or error-free. ROHM shall not be in any way responsible or liable for any damages, expenses or losses incurred by you or third parties resulting from inaccuracy or errors of or concerning such information.

1027 CABLE

© COPYRIGHT - By - ALL RIGHTS RESERVED.

P	LTR	DESCRIPTION	DATE	DWN	APVD
	F	ECR-18-000146	05JAN2018	RSM	KN

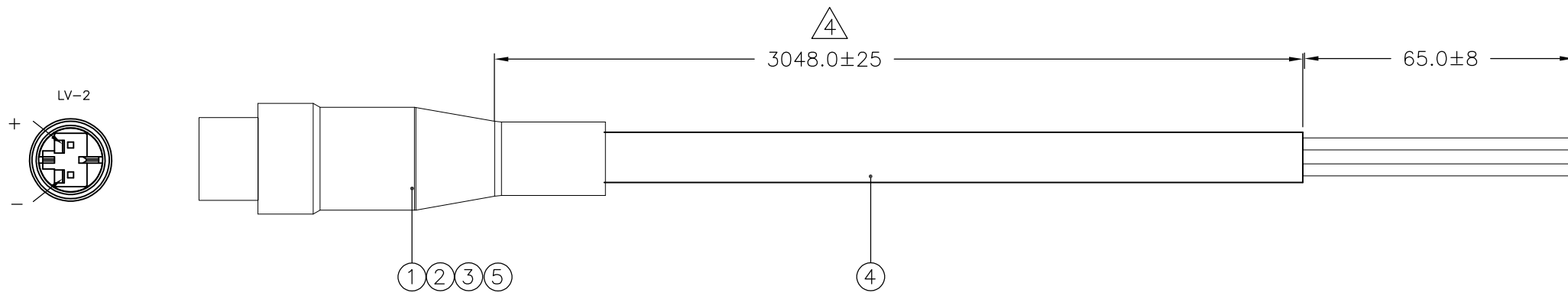

WIRING SCHEDULE ³

SIDE A	COLOR
+	WHT
-	BLK

NOTE:

- ¹ PACKAGING: ACCORDING TO TE SPEC. 107-18032 BUNDLE EVERY 25 ASSEMBLIES WITH A RUBBER BANDS.
- 2. ELECTRICAL TEST CONTAINING "SHORT CIRCUIT TEST, CONTINUITY AND ACCURATE CAVITY ASSIGNMENT TEST" ACC. TO TE-SPEC.108-18857, SUB-SECTION 3.1.1
- ³ WIRING SCHEDULE AS SHOWN
- ⁴ LENGTH DIMENSIONS ARE MEASURED FROM THE BACK END OF THE CONNECTOR PRIOR TO BOOT INSTALLATION.

1	1013035	2231986-1
CUST REV	CUST P/N	TE P/N

U/M	QTY	DESCRIPTION	ITEM
PC	1	CABLE TIE, 5.90" LENGTH, NATURAL	6
PC	1	BOOT, IP65	5
MM	3060.7	CABLE, SVT, 2X18AWG, UL, WHITE	4
PC	2	MICRO QUADLOCK SYSTEM PIN CONTACT	3
PC	1	TUBE FOR SVT CABLE	2
PC	1	OUTLET, MINI HVL 7.5MM, LV-2	1

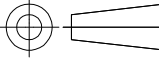
THIS DRAWING IS A CONTROLLED DOCUMENT.		DWN D. MCCLURE 24MAR14	 TE Connectivity CABLE ASSY, NECTOR S OUTLET TO PIGTAIL W/IP65 BOOT				
DIMENSIONS: mm		CHK D. MCCLURE 24MAR14				NAME	
		APVD D. MCCLURE 24MAR14				SIZE	
TOLERANCES UNLESS OTHERWISE SPECIFIED: 0 PLC ± - 1 PLC ± 2 PLC ± - 3 PLC ± - 4 PLC ± - ANGLES ± -		PRODUCT SPEC				CAGE CODE	
MATERIAL		FINISH	DRAWING NO		RESTRICTED TO		
-		-	A3 00779 C-2231986		-		
CUSTOMER DRAWING			SCALE	SHEET	REV		
			NTS	1 OF 2	F		

THIS DRAWING IS UNPUBLISHED.

RELEASED FOR PUBLICATION

-. - .

REVISIONS

© COPYRIGHT - By -

ALL RIGHTS RESERVED.

P	LTR	DESCRIPTION	DATE	DWN	APVD
-	-	SEE SHEET 1	-	-	-

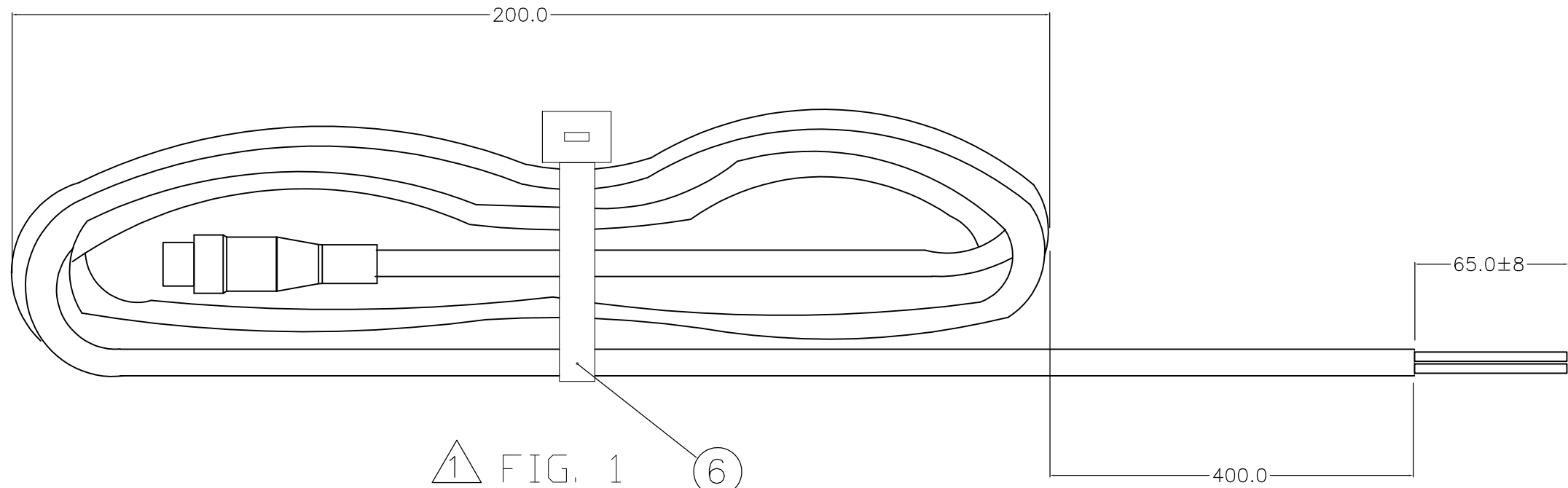

THIS DRAWING IS A CONTROLLED DOCUMENT.		DWN D. MCCLURE 24MAR14	 TE Connectivity														
DIMENSIONS: mm		CHK D. MCCLURE 24MAR14															
TOLERANCES UNLESS OTHERWISE SPECIFIED:		APVD D. MCCLURE 24MAR14	NAME CABLE ASSY, NECTOR S OUTLET TO PIGTAIL W/IP65 BOOT														
<table border="0"> <tr> <td>0 PLC</td> <td>± -</td> </tr> <tr> <td>1 PLC</td> <td>± 15</td> </tr> <tr> <td>2 PLC</td> <td>± -</td> </tr> <tr> <td>3 PLC</td> <td>± -</td> </tr> <tr> <td>4 PLC</td> <td>± -</td> </tr> <tr> <td>ANGLES</td> <td>± -</td> </tr> </table>		0 PLC	± -	1 PLC	± 15	2 PLC	± -	3 PLC	± -	4 PLC	± -	ANGLES	± -	PRODUCT SPEC -	APPLICATION SPEC -		
0 PLC	± -																
1 PLC	± 15																
2 PLC	± -																
3 PLC	± -																
4 PLC	± -																
ANGLES	± -																
MATERIAL -	FINISH -	WEIGHT -	SIZE A3	CAGE CODE 00779	DRAWING NO C-2231986	RESTRICTED TO -											
CUSTOMER DRAWING			SCALE NTS	SHEET 2 OF 2	REV F												

Mouser Electronics

Authorized Distributor

Click to View Pricing, Inventory, Delivery & Lifecycle Information:

[TE Connectivity:](#)

[2231986-1](#)

HC-B24-SG-RBK - Flat gasket



1407705

<https://www.phoenixcontact.com/us/products/1407705>

Please be informed that the data shown in this PDF document is generated from our online catalog. Please find the complete data in the user documentation. Our general terms of use for downloads are valid.

Replacement flat gasket, for HEAVYCON EVO panel mounting base type B24



Commercial data

Item number	1407705
Packing unit	10 pc
Minimum order quantity	10 pc
Sales key	BF66
Product key	AF7AUX
Catalog page	Page 652 (C-4-2015)
GTIN	4046356777995
Weight per piece (including packing)	8.05 g
Weight per piece (excluding packing)	7.5 g
Customs tariff number	40169300
Country of origin	DE

HC-B24-SG-RBK - Flat gasket



1407705

<https://www.phoenixcontact.com/us/products/1407705>

Technical data

Product properties

Product type	Seal
--------------	------

Material specifications

Material	NBR
----------	-----

Environmental and real-life conditions

Ambient conditions

Ambient temperature (operation)	-40 °C ... 125 °C
---------------------------------	-------------------

Mounting

Assembly note	For HC-EVO-B24.....BK housing
---------------	-------------------------------

HC-B24-SG-RBK - Flat gasket

1407705

<https://www.phoenixcontact.com/us/products/1407705>



Drawings

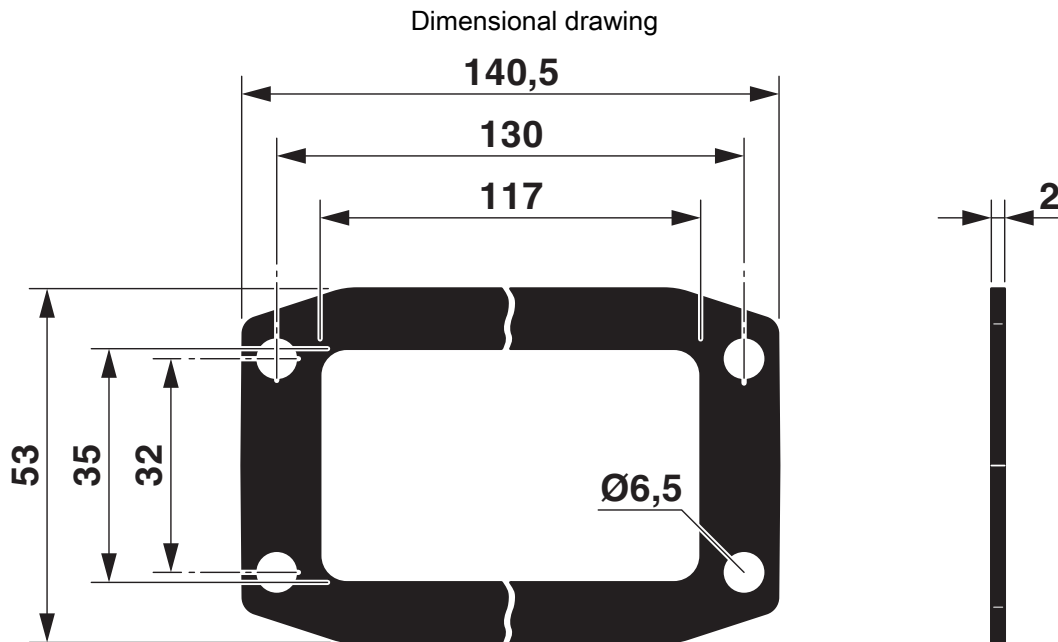

Dimensional drawing

HC-B24-SG-RBK - Flat gasket



1407705

<https://www.phoenixcontact.com/us/products/1407705>

Approvals

To download certificates, visit the product detail page: <https://www.phoenixcontact.com/us/products/1407705>



EAC

Approval ID: RU C-DE.AI30.B.01102

HC-B24-SG-RBK - Flat gasket



1407705

<https://www.phoenixcontact.com/us/products/1407705>

Classifications

ECLASS

ECLASS-11.0	23071590
ECLASS-12.0	23071590
ECLASS-13.0	23071590

ETIM

ETIM 9.0	EC002498
----------	----------

UNSPSC

UNSPSC 21.0	31401600
-------------	----------

HC-B24-SG-RBK - Flat gasket



1407705

<https://www.phoenixcontact.com/us/products/1407705>

Environmental product compliance

EU RoHS

Fulfills EU RoHS substance requirements	Yes, No exemptions
---	--------------------

China RoHS

Environment friendly use period (EFUP)	EFUP-E
	No hazardous substances above the limits

EU REACH SVHC

REACH candidate substance (CAS No.)	No substance above 0.1 wt%
-------------------------------------	----------------------------

Phoenix Contact 2025 © - all rights reserved
<https://www.phoenixcontact.com>

Phoenix Contact USA
586 Fulling Mill Road
Middletown, PA 17057, United States
(+717) 944-1300
info@phoenixcon.com



nRF52810

High performance, entry-level Bluetooth 5/ANT/2.4GHz SoC

A Bluetooth 5 SoC for everybody

The nRF52810 is the baseline member of the nRF52 Series SoC family. Together with the nRF52811, nRF52832 and the nRF52840 SoCs it completes our lineup of Bluetooth 5 devices that collectively offer the full spectrum of possibilities when designing *Bluetooth*® 5 into your products.

The nRF52810 supports the 2 Mbps bitrate of Bluetooth 5 giving increased application throughput and up to 50 % savings in energy usage. It supports channel selection algorithm #2 (CSA #2), improving the ability to coexist with other Bluetooth LE devices. It is an extremely cost-effective solution that makes it attractive in a wide range of applications.

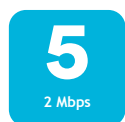

Bluetooth 5	nRF52810	nRF52811	nRF52832	nRF52840
2 Mbps	X	X	X	X
CSA #2	X	X	X	X
Advertising Extensions		(X)	X	X
Long Range		(X)		X

(X) Software support planned

Stand-alone performance or network processor

The nRF52810 is the ideal compromise between advanced performance, functionality and cost. It is more than powerful enough to be used as a stand-alone SoC in middle to lower tier applications. Or it can be the perfect companion network processor, combining Bluetooth 5 connectivity with a more powerful main application processor.

Over-the-air device firmware update

The nRF52810 and all nRF52 Series are flash-based SoCs and as such, fully support over-the-air device firmware updates (OTA DFU). This allows for in the field updates of application software and SoftDevices.

KEY FEATURES

- 64 MHz ARM® Cortex-M4
- 192 KB Flash + 24 KB RAM
- Bluetooth 5 2.4 GHz transceiver
 - 2 Mbps
 - CSA #2
 - Concurrent multiprotocol operation
 - +4 dBm TX Power
 - -96 dBm Sensitivity
 - 4.6 mA TX (0 dBm)
 - 4.6 mA RX (1 Mbps)
 - Integrated balun with 50 Ω single-ended output
- 1.7-3.6 V supply voltage range
- Integrated DC-DC regulator
- 0.3 µA in System OFF
- 1.5 µA in System ON with RTC
- Full range of digital interfaces with EasyDMA
- 12-bit 200 ksp/s ADC
- Small size

APPLICATIONS

- Beacons
- Network processor
- Disposable medical sensors
- PC peripherals
- Remote controls
- Fitness sensors
- Toys
- Logistics and tagging
- Airfuel wireless charging

SI12 SoftDevice

Our protocol stacks are called SoftDevices, and complement the nRF52 Series SoCs. SoftDevices are qualified, pre-compiled and link-free libraries that we provide. SoftDevices reside in separate memory space to the application and are interfaced by their API making application development simpler and more predictable.

The SI12 SoftDevice is a memory-optimized Bluetooth 5 protocol stack developed specifically for the nRF52810. High application throughput is available through the 2 Mbps bitrate of Bluetooth 5. It supports up to four peripheral connections with one concurrent broadcaster and is highly configurable, meaning it can be tailored to your application requirements.

nRF52810 compatible SoftDevices

SI12	Memory-optimized Bluetooth 5 protocol stack for the nRF52810, nRF52811 and nRF52832 SoCs
SI32	High performance Bluetooth 5 protocol stack for the nRF52810 and nRF52832 SoCs
S212	ANT stack for the nRF52810 and nRF52832 SoCs
S312	Combined Bluetooth 5 and ANT protocol stack for the nRF52810 SoC

RELATED PRODUCTS

nRF52 DK	Development kit for nRF52810 and nRF52832 SoCs
nRF52811	SoC for Bluetooth 5.1/802.15.4/Thread/Zigbee/ANT/2.4 GHz
nRF52832	SoC for Bluetooth 5/Bluetooth mesh/ANT/2.4 GHz
nRF52840	SoC for Bluetooth 5/Bluetooth mesh/ 802.15.4/Thread/Zigbee/ANT/2.4 GHz
nRF5 SDK	Main software development kit for Bluetooth 5, ANT and 802.15.4
Power Profiler Kit	Current measurement tool for embedded development

SPECIFICATIONS

Protocol support	Bluetooth 5/ANT/2.4 GHz proprietary
Microprocessor	64 MHz 32-bit ARM Cortex-M4
Memory	192 KB Flash + 24 KB RAM
On-air data rate	2 Mbps/1 Mbps
TX power	Programmable from +4 to -20 dBm in 4 dB steps
Sensitivity	Bluetooth 5: -93 dBm at 2 Mbps -96 dBm at 1 Mbps ANT: -93 dBm at 1 Mbps 2.4GHz: -93 dBm at 2 Mbps -96 dBm at 1 Mbps
Radio current consumption DC/DC at 3V	7.0 mA at +4 dBm TX power, 4.6 mA at 0 dBm TX power, 4.6 mA in RX at 1 or 2 Mbps
Oscillators	64 MHz from 32 MHz external crystal or internal 32 kHz from crystal, RC or synthesized
System current consumption DC/DC at 3 V	0.3 µA in System OFF, no RAM retention 0.5 µA in System OFF, full RAM retention 0.6 µA in System ON, no RAM retention 0.8 µA in System ON, full RAM retention 1.5 µA in System ON, full RAM retention and RTC
Hardware security	128-bit AES CCM, ECB, AAR
Digital interfaces	SPI master/slave TWI master/slave UART PWM QDEC PDM
Analog interfaces	12-bit 200 ksps ADC, RNG, GP comparator
Peripherals	3 × 32-bit Timer 2 × 24-bit RTC 20 × PPI channels 4 × GPIOTE Watchdog timer RNG Temperature sensor BPROT – flash protection
Voltage supply	1.7 to 3.6 V LDO or DC/DC
Package options	6 × 6 QFN48 with 32 GPIOs 5 × 5 QFN32 with 16 GPIOs 2.48 × 2.46 WLCSP33 with 15 GPIOs

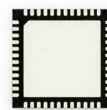

6×6 mm



5×5 mm



2.48×2.46 mm

WORLD WIDE OFFICE LOCATIONS

Headquarters:
Trondheim, Norway
Tel: +47 72 89 89 00

For more information

Visit nordicsemi.com for the complete product specification about this and any other wireless ULP products.

About Nordic Semiconductor

Nordic Semiconductor is a fabless semiconductor company specializing in ULP short-range wireless communication. Nordic is a public company listed on the Norwegian stock exchange.



MODEL: CMC-4013-2-SMT-TR | **DESCRIPTION:** ELECTRET CONDENSER MICROPHONE**FEATURES**

- omnidirectional
- low profile
- surface mount
- tape and reel packaging

**SPECIFICATIONS**

parameter	conditions/description	min	typ	max	units
directivity	omnidirectional				
sensitivity [S]	f = 1 kHz, 1 Pa, 0 dB = 1 V/Pa	-45	-42	-39	dB
standard operating voltage [Vs]			2		Vdc
max operating voltage				10	Vdc
output impedance [Zout]	f = 1 kHz, 1 Pa		2.2		kΩ
sensitivity reduction [ΔS-Vs]	f = 1 kHz, 1 Pa, Vs = 3.0 ~ 2.0 Vdc		-3		dB
frequency [f]		20		20,000	Hz
current consumption [IDSS]	Vs = 2.0 Vdc, RL = 2.2 kΩ			0.5	mA
signal to noise ratio [S/N]	f = 1 kHz, 1 Pa, A-weighted		58		dBa
acoustic overload point [ADP]	THD<3%			105	dB SPL
dimensions	∅4.0 x 1.3				mm
material	zinc white copper				
terminal	SMT type				
weight				0.065	g
operating temperature		-20		70	°C
storage temperature		-20		70	°C
RoHS	yes				

Notes: 1. We use the "Pascal [Pa]" indication of sensitivity as per the recommendation of I.E.C. (International Electrotechnical Commission). The sensitivity of "Pa" will increase 20 dB compared to the "ubar" indication. Example: -60 dB [0 dB = 1 V/ubar] = -40 dB [1V/Pa]
 2. All specifications measured at 5-35°C, humidity at 45-85%, under 86-106 kPa pressure, unless otherwise noted.

MECHANICAL DRAWING

units: mm
tolerance: ±0.2 mm

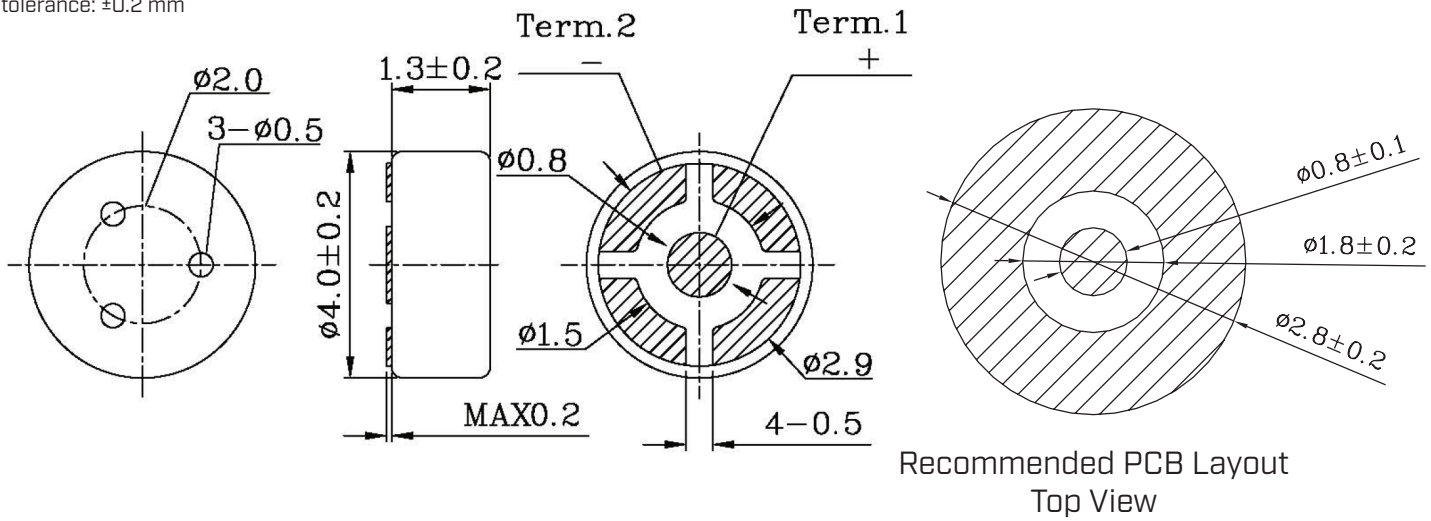

FREQUENCY RESPONSE CURVE

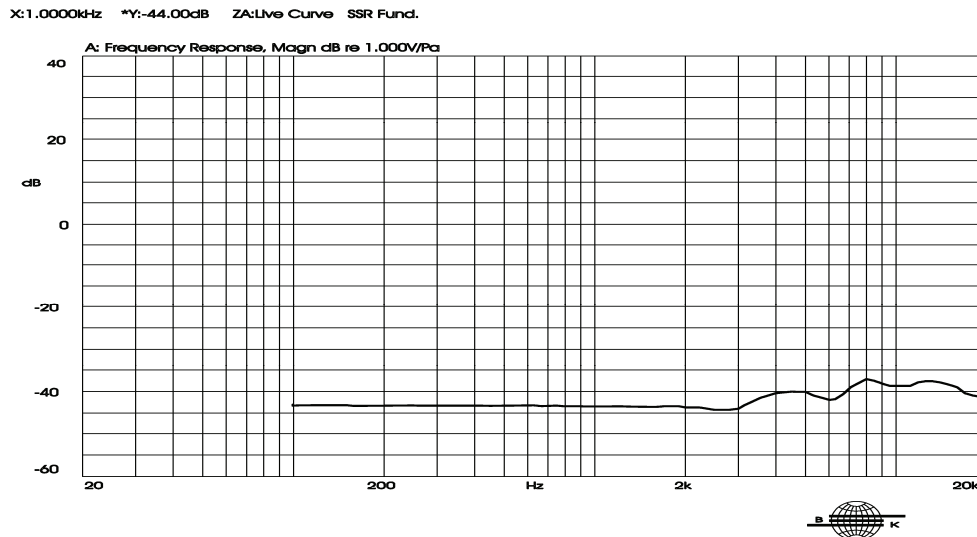

MEASUREMENT CIRCUIT

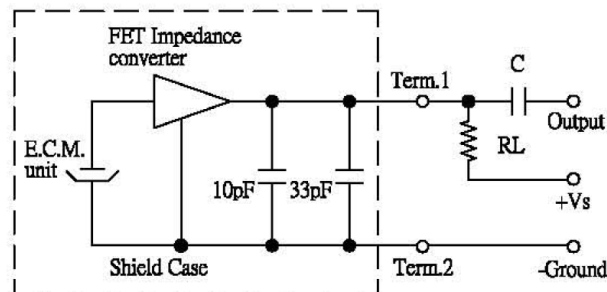

RL = 2.2 kΩ

SOLDERABILITY

parameter	conditions/description	min	typ	max	units
reflow soldering	see reflow soldering profile	245	250	255	°C

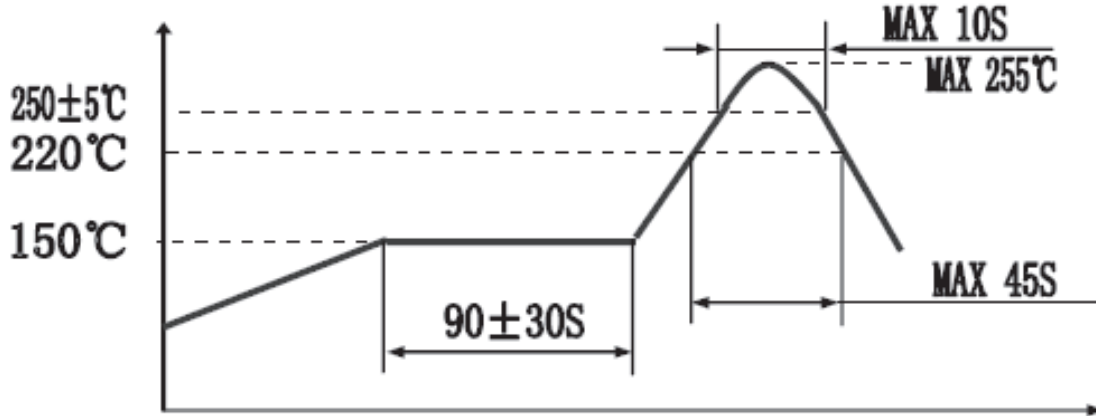

PACKAGING

units: mm

Reel Size: Ø330 mm
 Inner Bag Size: 340 x 340 x 30 mm
 Carton Box Size: 340 x 170 x 340 mm
 Reel QTY: 3,800 pcs per reel
 Inner Bag QTY: 3,800 pcs per box
 Carton Box QTY: 19,000 pcs per carton

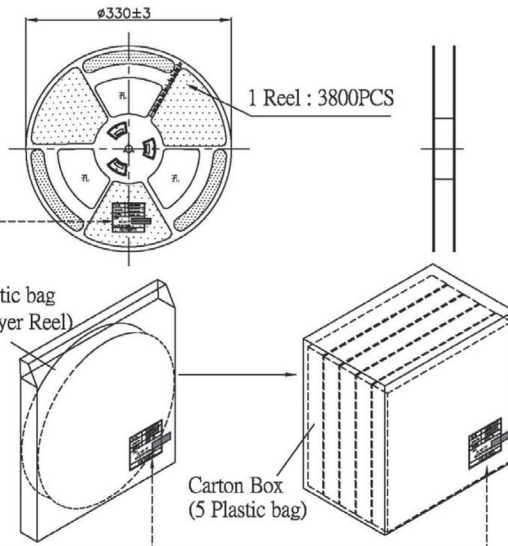
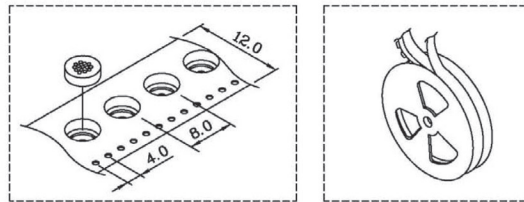

Lot No.	XXXXXXXXXX
Model No.	XXXXXXXXXX
Quantity	XXXX Pcs
Date:	DD MM YY
	RoHS Compliant
	MADE IN CHINA

REVISION HISTORY

rev.	description	date
1.0	initial release	04/23/2021
1.01	updated packaging	08/05/2021
1.02	logo, datasheet style update	08/05/2022
1.03	CUI Devices rebranded to Same Sky	09/11/2024

The revision history provided is for informational purposes only and is believed to be accurate.



Same Sky offers a one (1) year limited warranty. Complete warranty information is listed on our website.

Same Sky reserves the right to make changes to the product at any time without notice. Information provided by Same Sky is believed to be accurate and reliable. However, no responsibility is assumed by Same Sky for its use, nor for any infringements of patents or other rights of third parties which may result from its use.

Same Sky products are not authorized or warranted for use as critical components in equipment that requires an extremely high level of reliability. A critical component is any component of a life support device or system whose failure to perform can be reasonably expected to cause the failure of the life support device or system, or to affect its safety or effectiveness.

[sameskydevices.com](https://www.sameskydevices.com)

Mouser Electronics

Authorized Distributor

Click to View Pricing, Inventory, Delivery & Lifecycle Information:

[Same Sky:](#)

[CMC-4013-2-SMT-TR](#)



MODEL: CMS-1545-058L55 | **DESCRIPTION:** SPEAKER

FEATURES

- 8 ohm
- rated 0.5 W
- lead wire



SPECIFICATIONS

parameter	conditions/description	min	typ	max	units
input power	maximum power: IEC-60268-5 filter 60s on/120s off 10 cycles (room temp.)		0.5	0.8	W
impedance	DCR at 2.0 kHz, 1.0 V	6.12 6.8	7.20 8.0	8.28 9.2	Ω Ω
resonant frequency (Fo)	at 1.0 V	800	1,000	1,200	Hz
frequency response		Fo		20,000	Hz
sound pressure level	at 0.5 W, 10 cm, avg at 0.8, 1.0, 1.5, 2.0 kHz	87	90	93	dB
distortion	at 1.0 kHz, rated power			10	%
buzz, rattle, etc.	must be normal at sine wave, from Fo to 20 kHz			2.0	V
polarity	cone moves forward w/ positive dc current to "+" terminal				
dimensions	\varnothing 15.0 x 4.5				mm
magnet	Nd-Fe-B				
frame material	PBT				
cone material	PEN				
terminal	wire leads				
weight			1.4		g
operating temperature		-20		55	$^{\circ}$ C
storage temperature		-30		70	$^{\circ}$ C
hand soldering	for 1~3 seconds	360	370	380	$^{\circ}$ C
RoHS	yes				

Notes: 1. All specifications measured at 15-35 $^{\circ}$ C, humidity at 45-85%, under 86-106 kPa pressure, unless otherwise noted.

MECHANICAL DRAWING

units: mm
tolerance: ± 0.3 mm

wire: UL1571 32 AWG

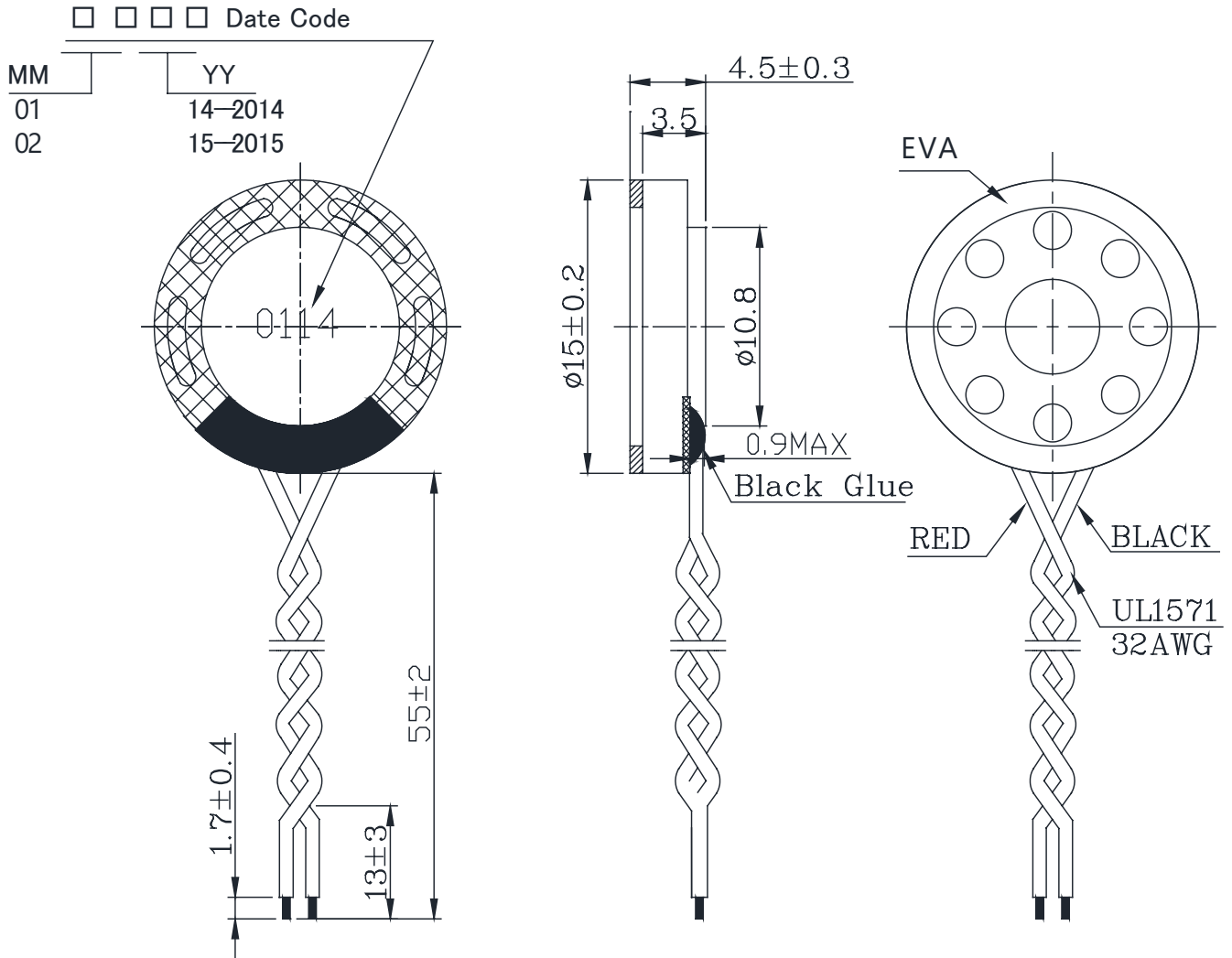

RESPONSE CURVES

Frequency Response Curve

Test Conditions: 0.5 W/0.1 m

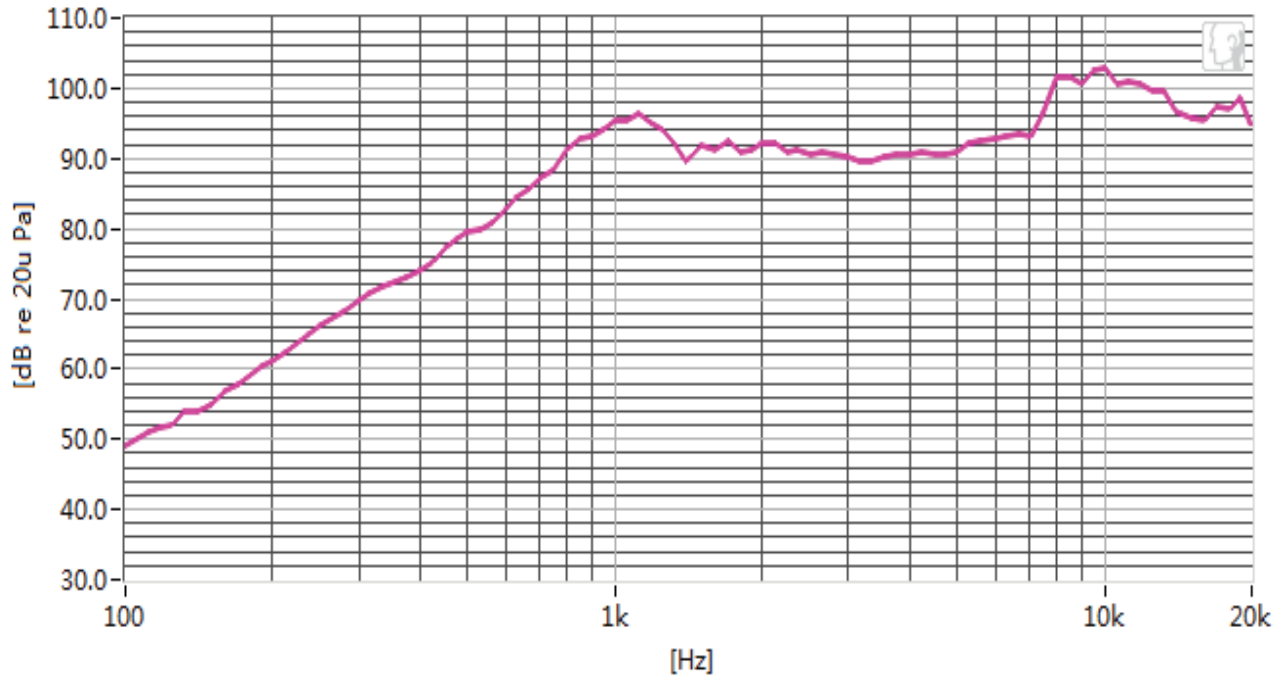

Total Harmonic Distortion Curve

Test Conditions: 0.5 W/0.1 m

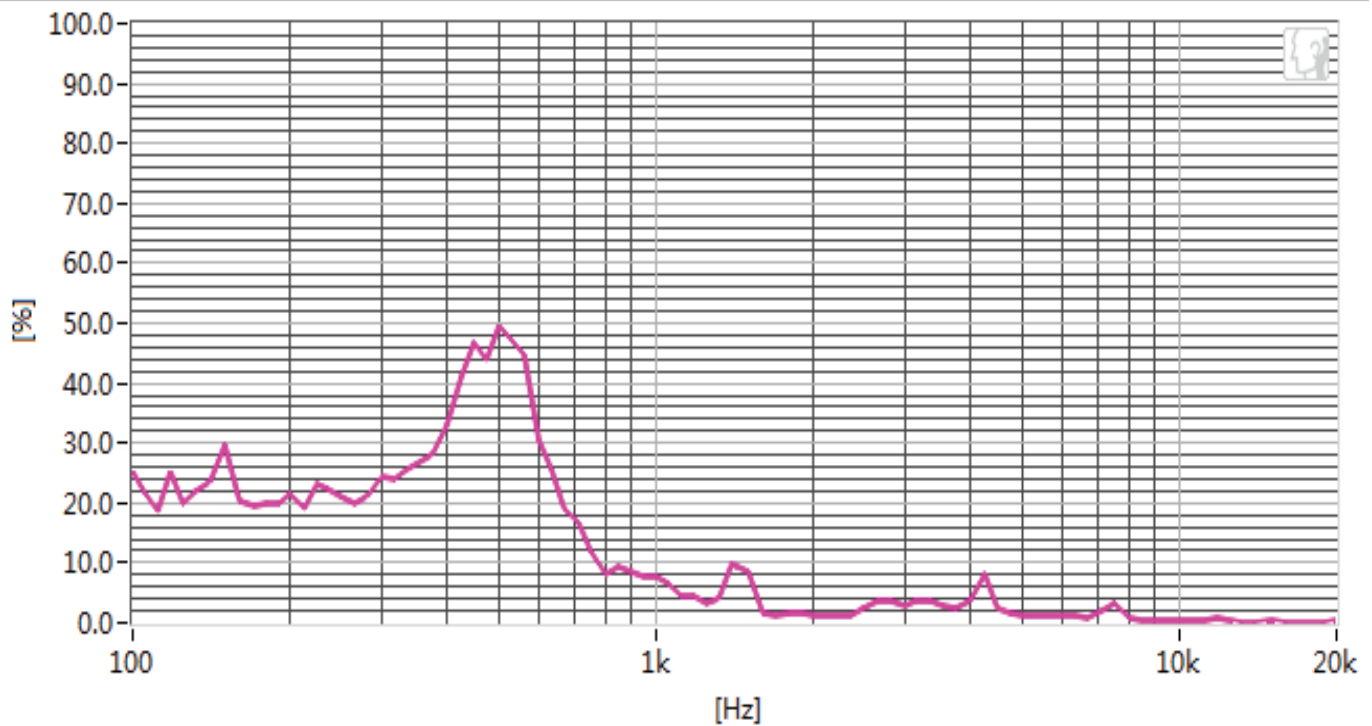

REVISION HISTORY

rev.	description	date
1.0	initial release	06/14/2024
1.01	CUI Devices rebranded to Same Sky	09/11/2024

The revision history provided is for informational purposes only and is believed to be accurate.



Same Sky offers a one (1) year limited warranty. Complete warranty information is listed on our website.

Same Sky reserves the right to make changes to the product at any time without notice. Information provided by Same Sky is believed to be accurate and reliable. However, no responsibility is assumed by Same Sky for its use, nor for any infringements of patents or other rights of third parties which may result from its use.

Same Sky products are not authorized or warranted for use as critical components in equipment that requires an extremely high level of reliability. A critical component is any component of a life support device or system whose failure to perform can be reasonably expected to cause the failure of the life support device or system, or to affect its safety or effectiveness.

[sameskydevices.com](https://www.sameskydevices.com)

Mouser Electronics

Authorized Distributor

Click to View Pricing, Inventory, Delivery & Lifecycle Information:

[Same Sky:](#)

[CMS-1545-058L55](#)

1025 ON/OFF BUTTON

Materials			
No	Component name	Base material	Plating
1	Housing	Diallyl phthalate resin	
2	End terminal	silver clad copper alloy	gold flash
3	Center terminal	copper alloy	gold flash
4	Rocker contact	silver clad copper alloy	gold flash
5	Actuator tip	Phenol resin, UL94 HB	
6	Actuator spring	music wire	
7	Actuator	Phenol resin, UL94 HB	
8	Actuator guide	polyamid resin	
9	Frame	cold rolled steel	zinc
10	Retainer	brass	none
11	Plunger spring	music wire	
12	Plunger pin	brass	
13	Bushing	zinc	nickel
14	Plunger	brass	nickel
15	Mounting nuts (2)	brass	nickel
16	Locating ring	cold rolled steel	nickel
17	Internal tooth lockwasher	steel	nickel

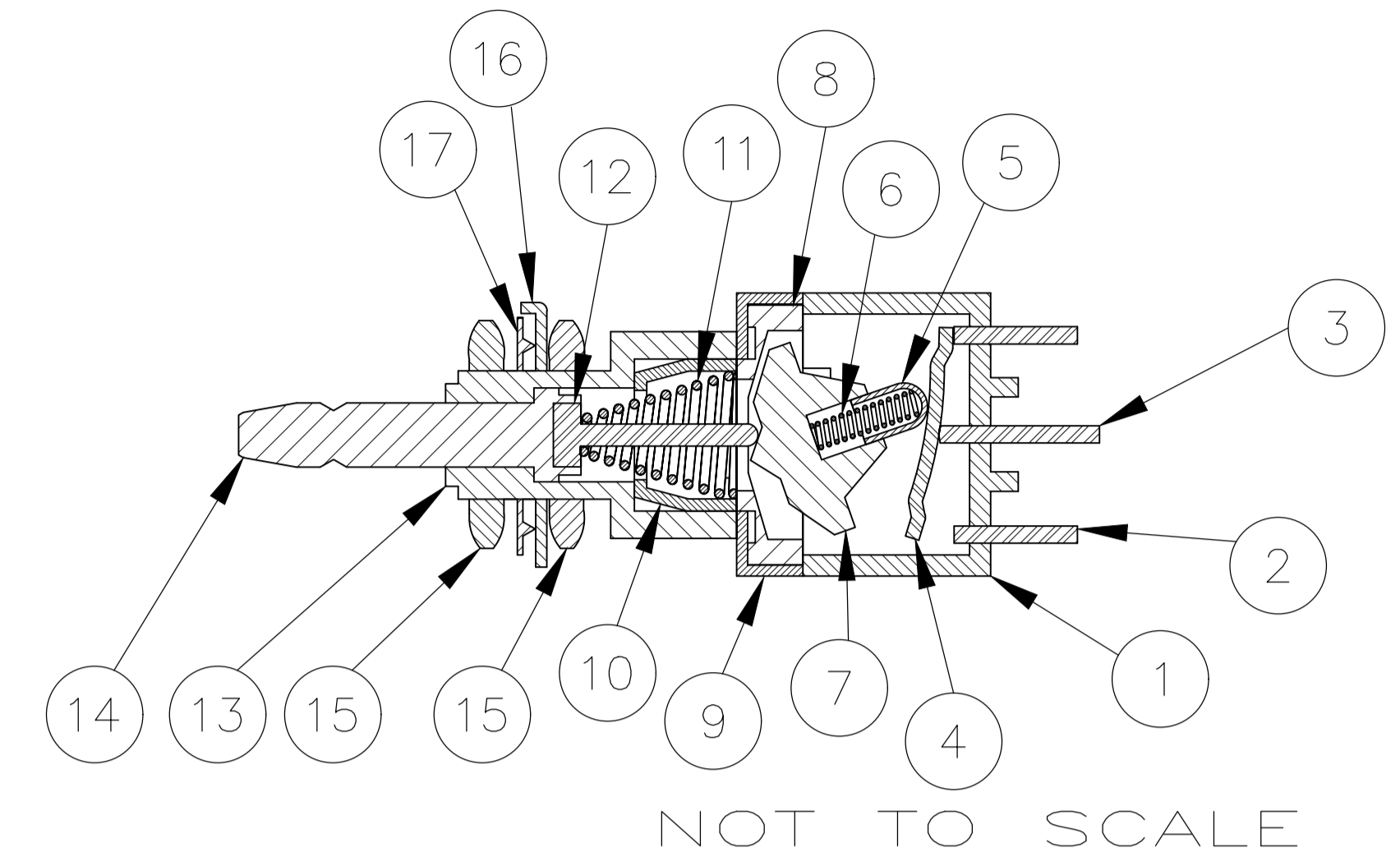

NOT TO SCALE

Specifications-see note 3			
Current rating UL & CSA	6A @ 125 VAC (resistive)		
	3A @ 250 VAC (resistive)		
	4A @ 28 VDC (resistive)		
Initial contact resistance	10 milliohms max @ 2-4 VDC, 1A		
Insulation resistance	1,000 megohms min.		
Dielectric strength	1,500 VAC		
Travel	.140		
Actuation force	.4 to 2 kgf		
Operating temperature	-20C to +85C		
Storage temperature	-40C to +85C		
Contact timing	break before make		
Terminal seal	over molded		
Durability	Parameter	Push on/ Push off	Momentary
	250 VAC (3A resistive)	50,000	50,000
	125 VAC (6A resistive)	50,000	50,000
	28 VDC (4A resistive)	50,000	50,000

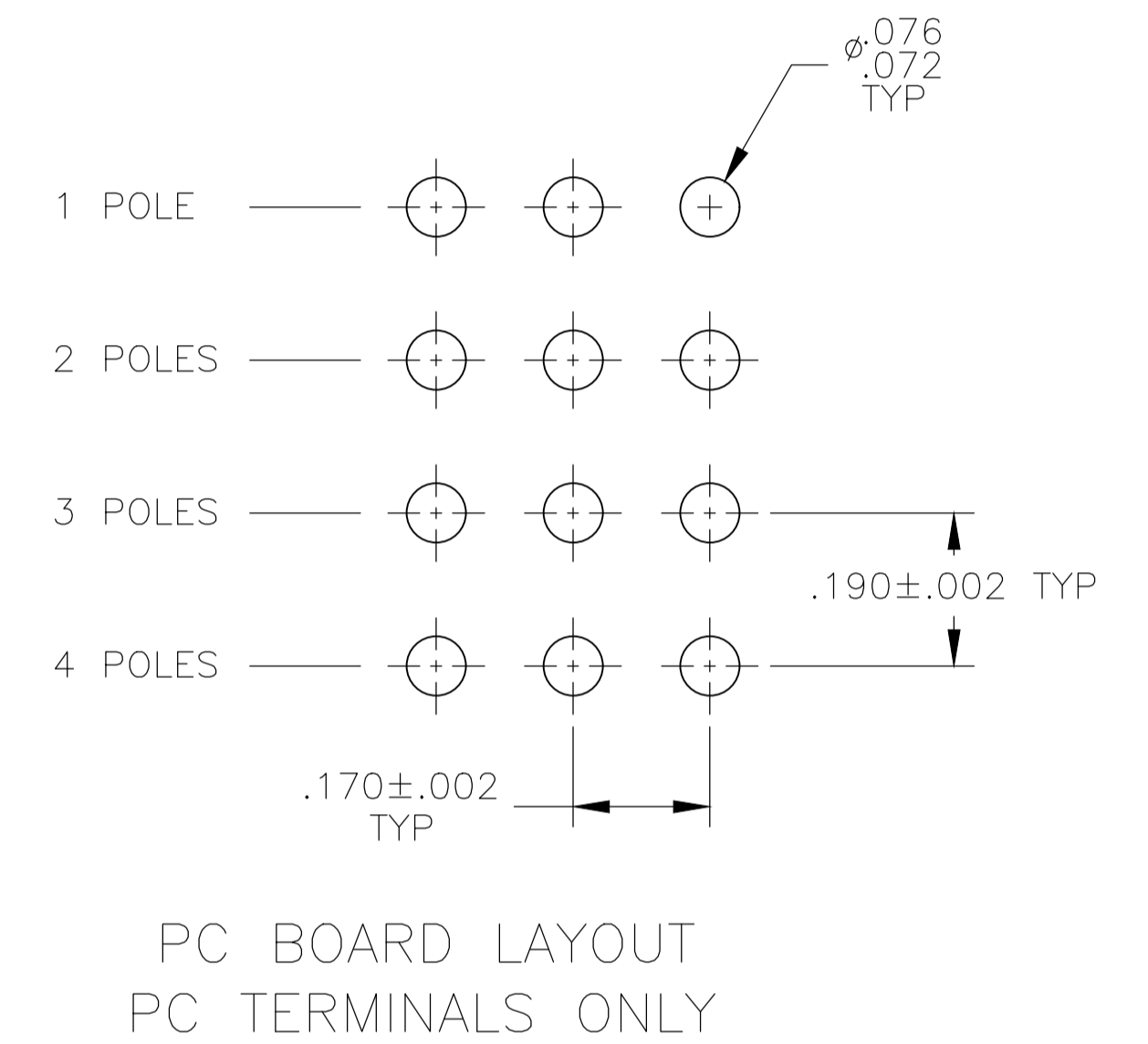
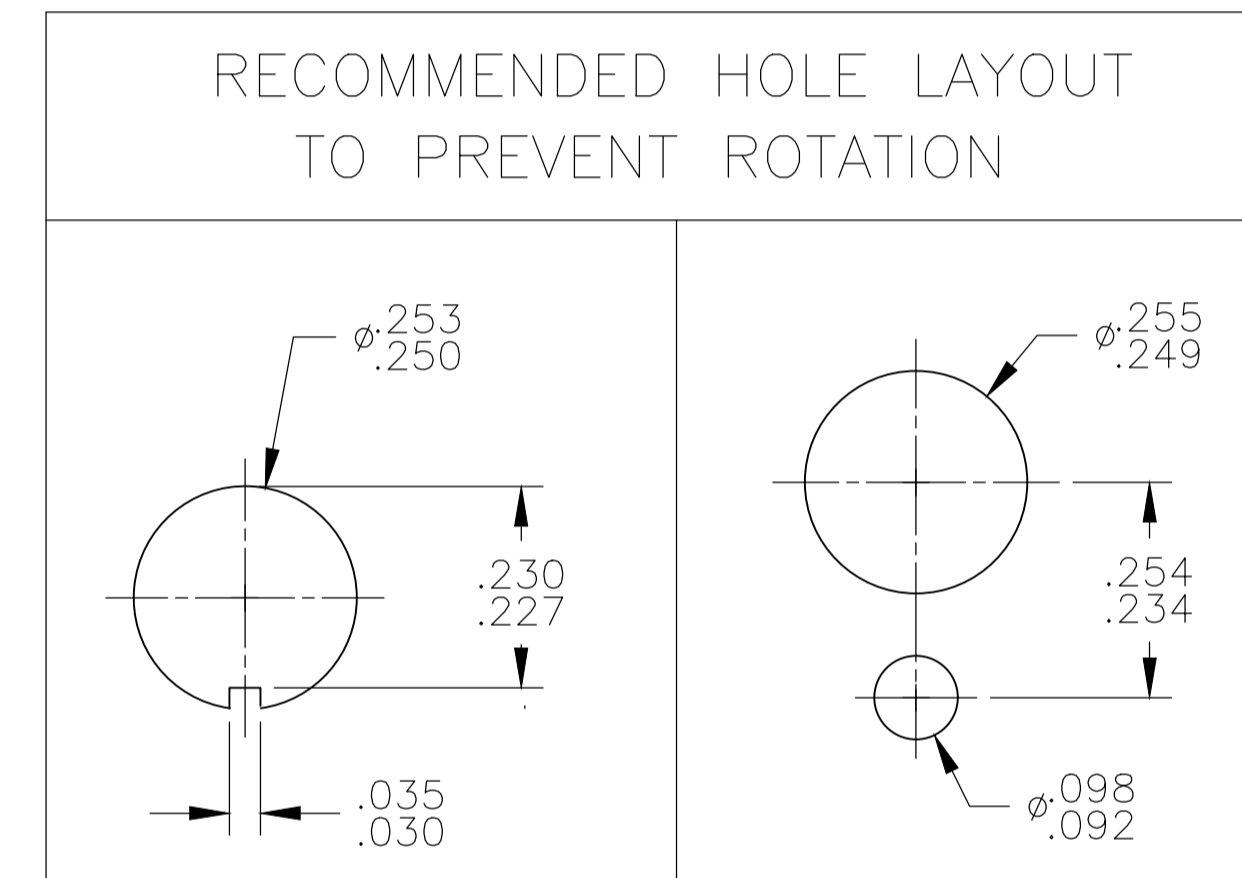

PART NUMBER	Alco P/N	Mark Switch	Poles	Throws	Terminal	Function		Connected Terminals	
						ON	MOM	ON	MOM
3-1437567-8	MPA406R	MPA 406R	4	2	Wire lug	ON	MOM	2-1, 5-4, 8-7, 11-10	2-3, 5-6, 8-9, 11-12
3-1437567-7	MPA406N	MPA 406N	4	2	Wire lug	ON	ON	2-1, 5-4, 8-7, 11-10	2-3, 5-6, 8-9, 11-12
3-1437567-6	MPA306F	MPA 306F	3	2	Wire lug	ON	MOM	2-1, 5-4, 8-7	2-3, 5-6, 8-9
3-1437567-5	MPA306D	MPA 306D	3	2	Wire lug	ON	ON	2-1, 5-4, 8-7	2-3, 5-6, 8-9
3-1437567-4	MPA206RPC	MPA 206RPC	2	2	PC	ON	MOM	2-1, 5-4	2-3, 5-6
3-1437567-3	MPA206R	MPA 206R	2	2	Wire lug	ON	MOM	2-1, 5-4	2-3, 5-6
3-1437567-2	MPA206NPC	MPA 206NPC	2	2	PC	ON	ON	2-1, 5-4	2-3, 5-6
3-1437567-1	MPA206N	MPA 206N	2	2	Wire lug	ON	ON	2-1, 5-4	2-3, 5-6
3-1437567-0	MPA106FPC	MPA 106FPC	1	2	PC	ON	MOM	2-1	2-3
2-1437567-9	MPA106F	MPA 106F	1	2	Wire lug	ON	MOM	2-1	2-3
2-1437567-8	MPA106D	MPA 106D	1	2	Wire lug	ON	ON	2-1	2-3

- NOTES:
- TERMINAL NUMBERS ARE FOR REFERENCE ONLY AND DO NOT APPEAR ON THE SWITCHES.
 - EACH SWITCH SUPPLIED WITH THE FOLLOWING MOUNTING HARDWARE:
 - (2) 1/4-40 UNS-2B HEX NUTS
 - (1) INTERNAL TOOTH LOCKWASHER
 - (1) LOCATING RING
 - WIRE LUG CONTACTS WILL ACCEPT 2 #20 AWG SOLID OR STRANDED WIRES.
 - MARK SWITCH
 - ALL MATERIALS AND FINISHES SHALL COMPLY WITH EU DIRECTIVE 2002/95/EC OF 27JAN2003 (ROHS).
 - SWITCH DOES NOT INCLUDE BUTTON CAP. DIMENSIONS SHOWN DESCRIBE ALCO SWITCH CAP C22* AND C23* FOUND ON DRAWINGS 1825068 & 1825069 AND SOLD SEPARATELY.
 - LASER MARKING USED FOR PARTS.
 - OBSOLETE

THIS DRAWING IS A CONTROLLED DOCUMENT.

DIN M. BINNER 02MAR09
 CHK: M. ZITTO 15NOV04
 APVD: M. ZITTO 15NOV04
 NAME: ALCO SWITCH GREEN SERIES PUSHBUTTON SWITCH, MPA SERIES

STE TE Connectivity Ltd.

ALCO SWITCH GREEN SERIES PUSHBUTTON SWITCH, MPA SERIES

SIZE: A1 CASE CODE: 00779 DRAWING NO: 2-1437567-9
 WEIGHT: RESTRICTED TO

CUSTOMER DRAWING SCALE: 3:1 SHEET: 1 OF 3 REV: A5

REVISIONS				
#	DATE	DESCRIPTION	BY	APP'D
-	-	SEE SHEET 1	-	-

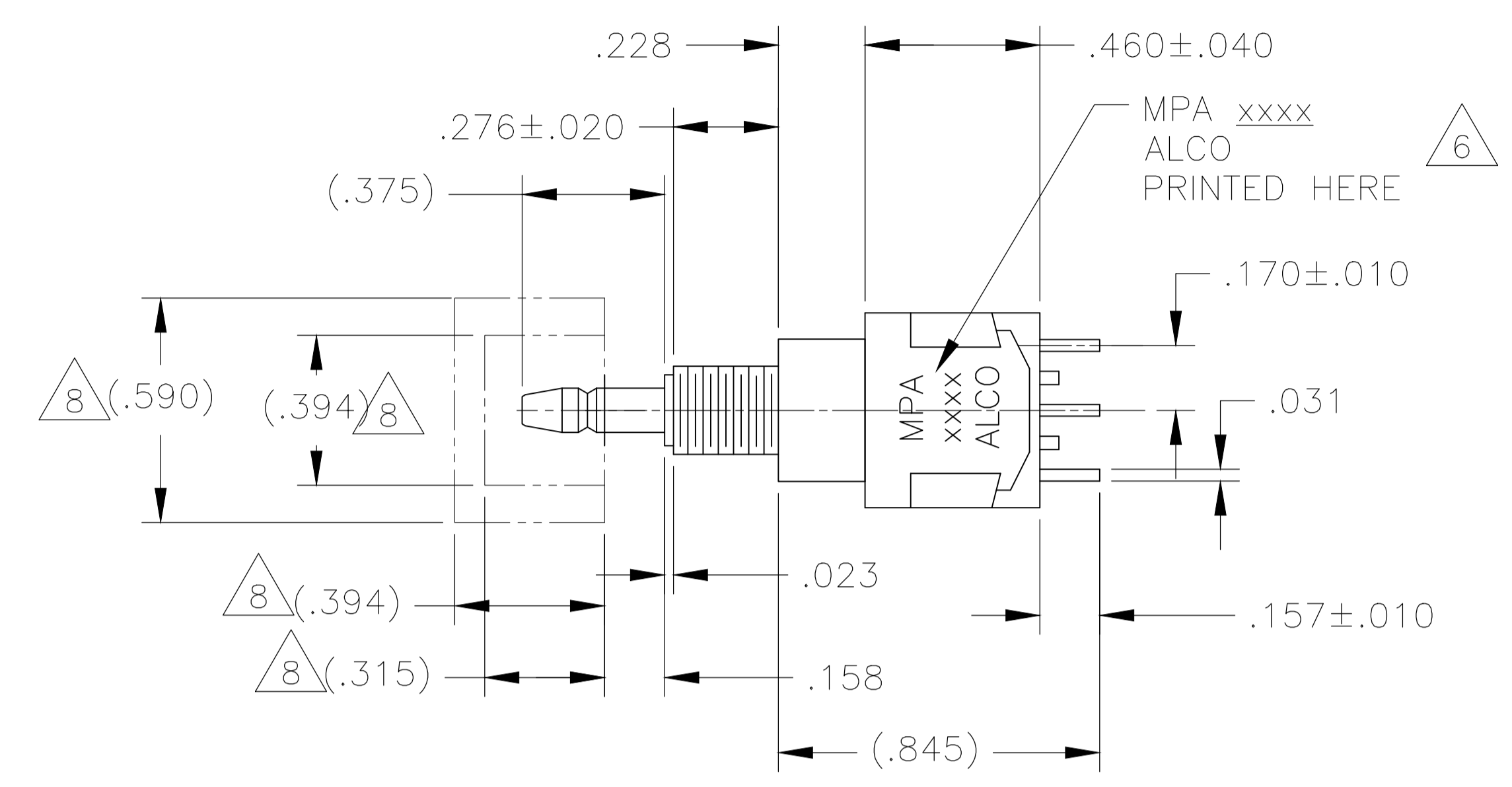

MPA-106

MPA-206

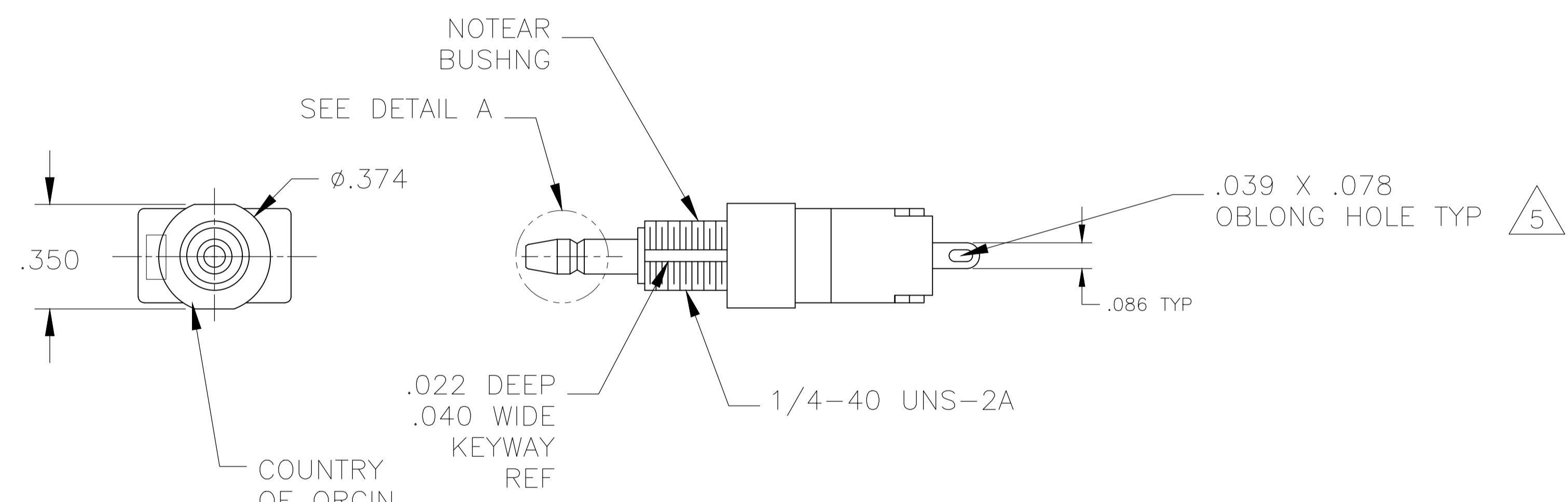

WIRE LUG TERMINAL

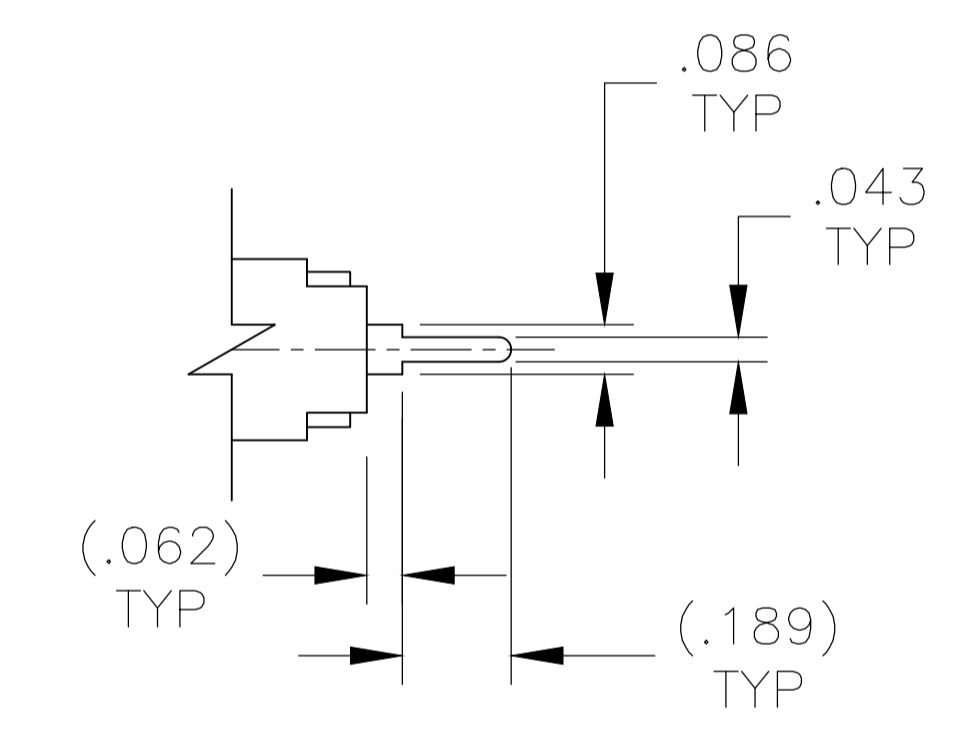

PC TERMINAL

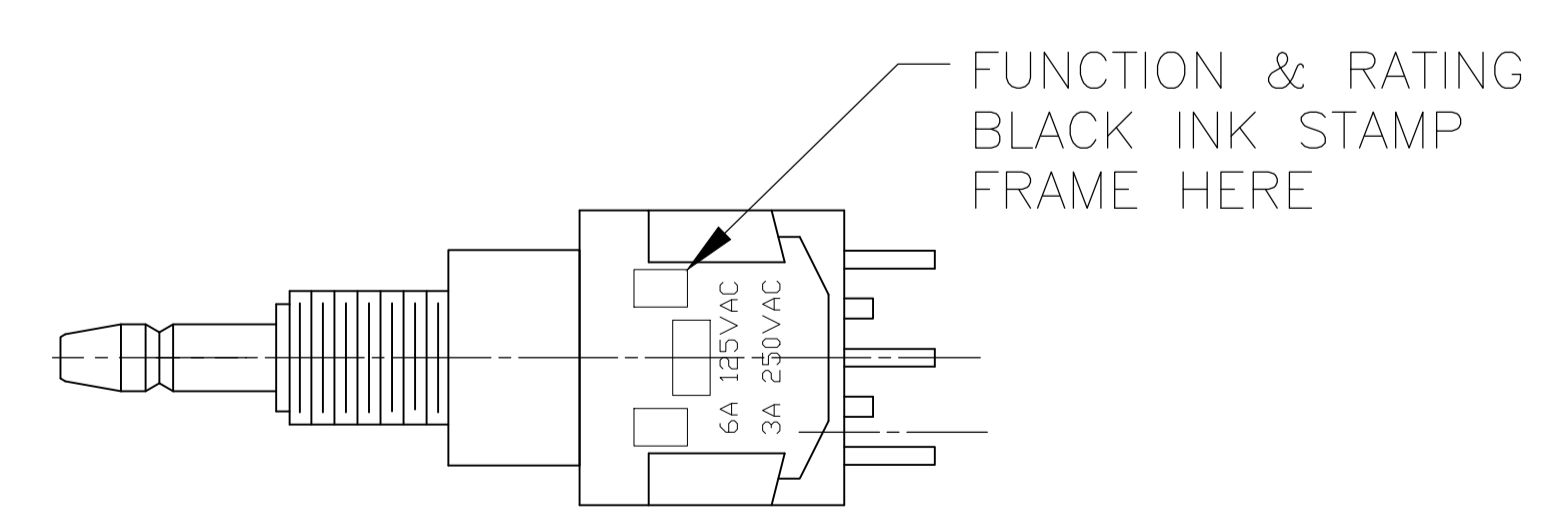

THIS DRAWING IS A CONTROLLED DOCUMENT.		DWG: M. BINNER 02MAR09	TE Connectivity Ltd.
DIMENSIONS: INCHES		CHK: M. ZITTO 15NOV04	
TOLERANCES UNLESS OTHERWISE SPECIFIED:		APP'D: M. ZITTO 15NOV04	NAME: ALCOSWITCH GREEN SERIES PUSHBUTTON SWITCH, MPA SERIES
0 PLC ± -	1 PLC ± -	PRODUCT SPEC	APPLICATION SPEC
2 PLC ± -	3 PLC ± .012	APPLIC. SPEC	RESTRICTED TO
4 PLC ± -	ANGLES ± -	WEIGHT	SIZE: A1 CAGE CODE: 2-1437567-9 DRAWING NO: 00779
MATERIAL: -	FINISH: -	CUSTOMER DRAWING	SCALE: 3:1 SHEET: 2 OF 3 REV: A5

REVISIONS				
#	LR	DESCRIPTION	DATE	OWN APVD
-	-	SEE SHEET 1	-	-

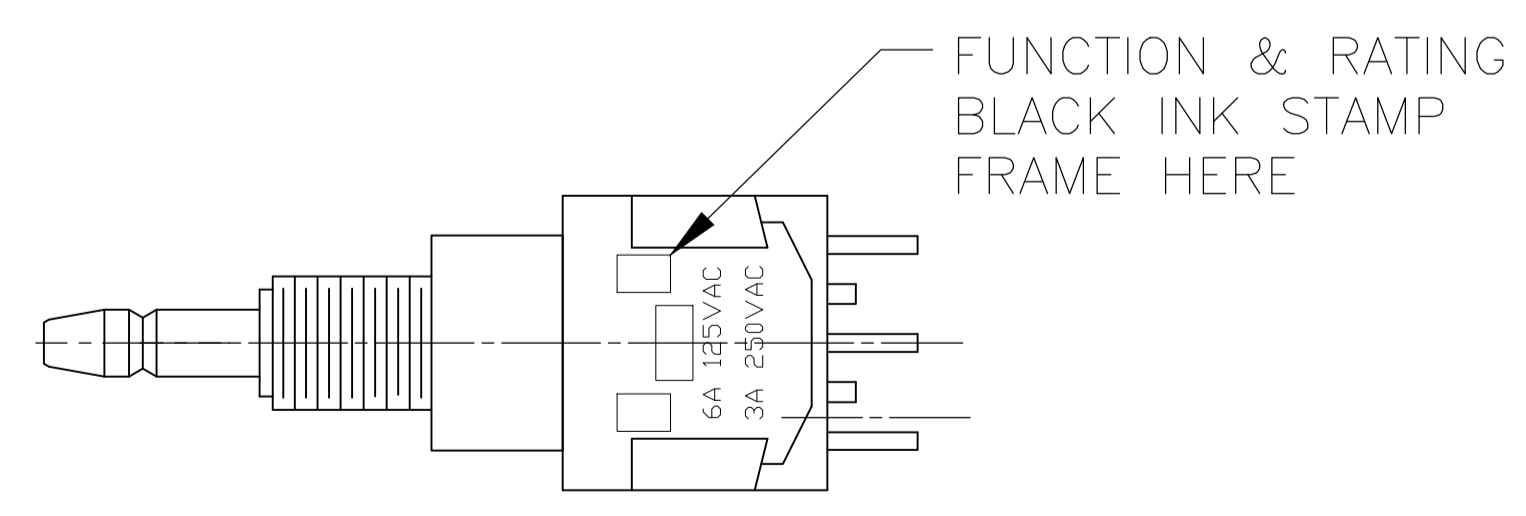
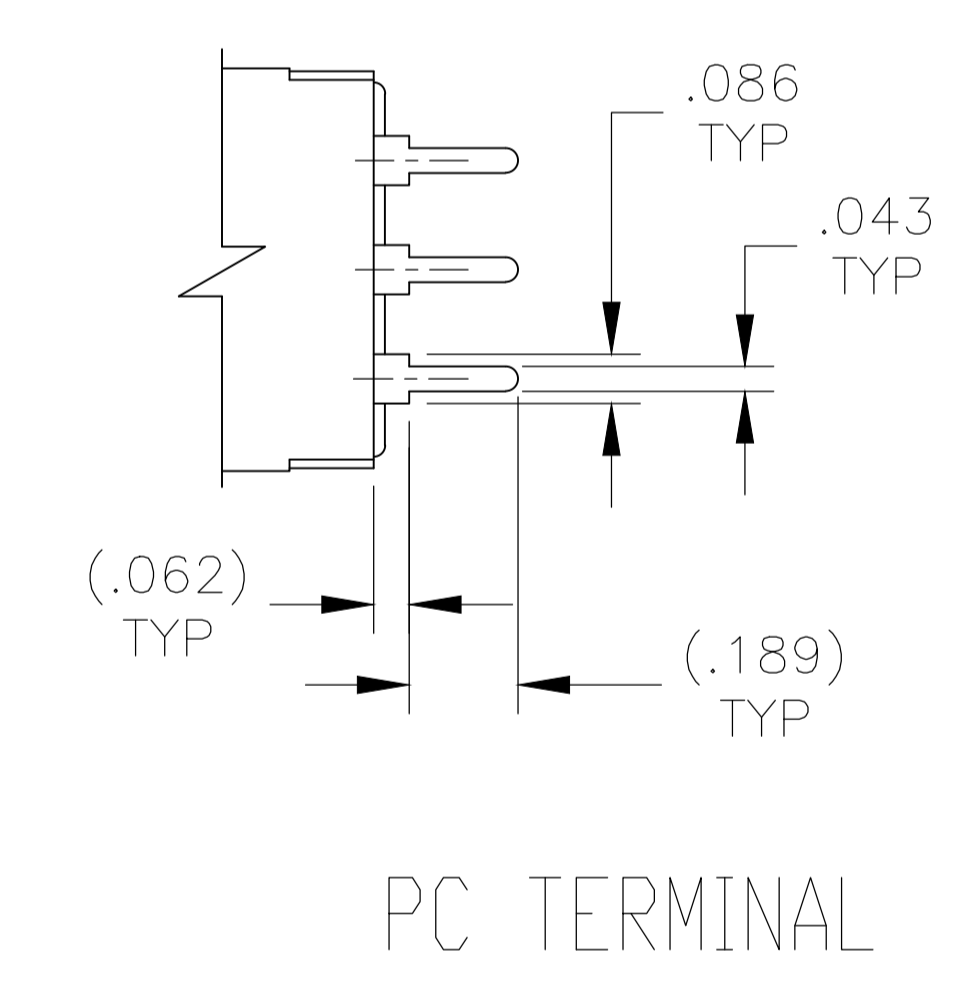
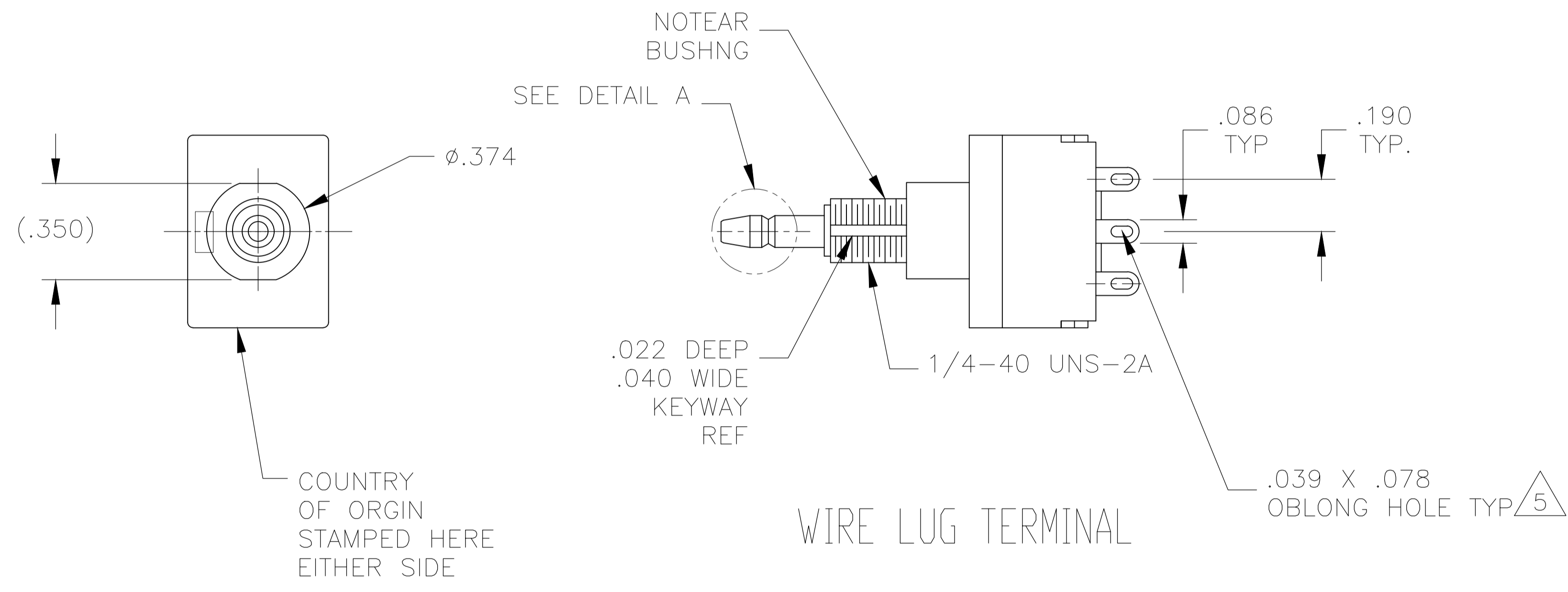
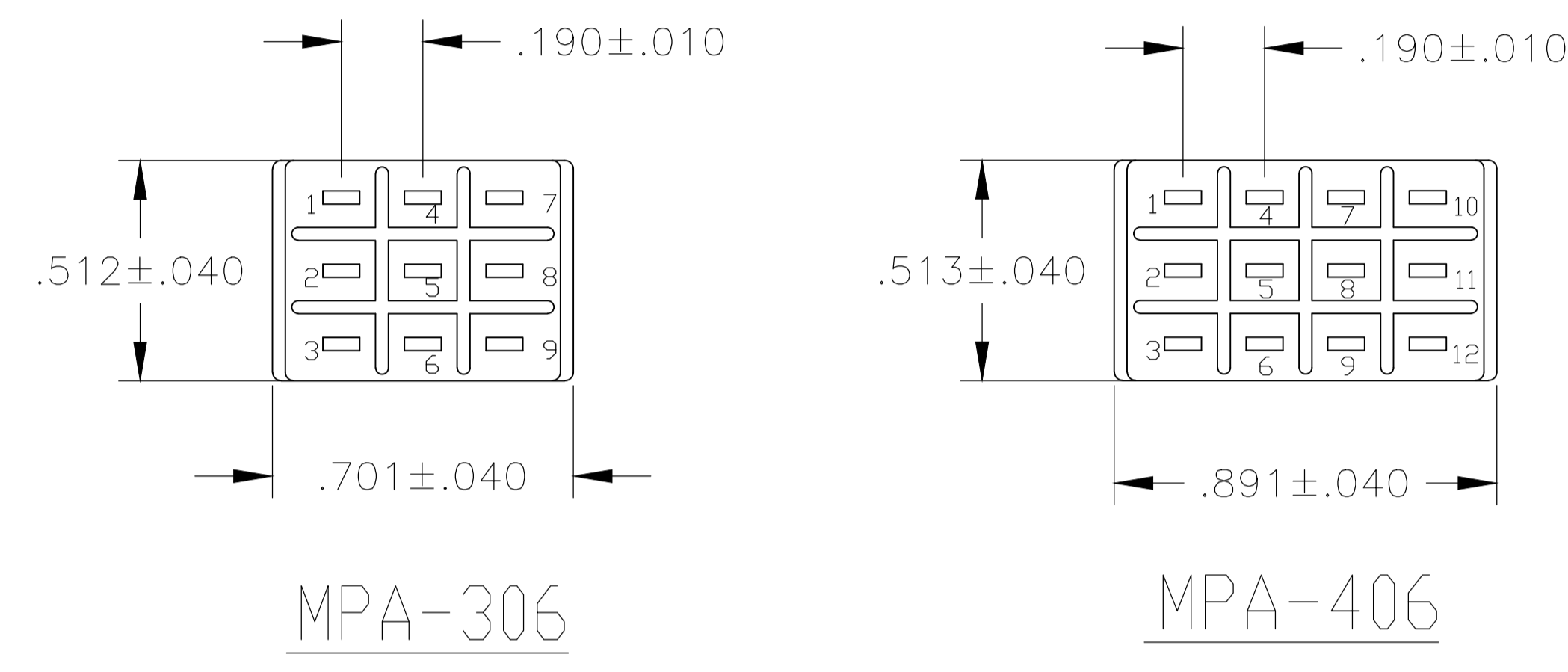
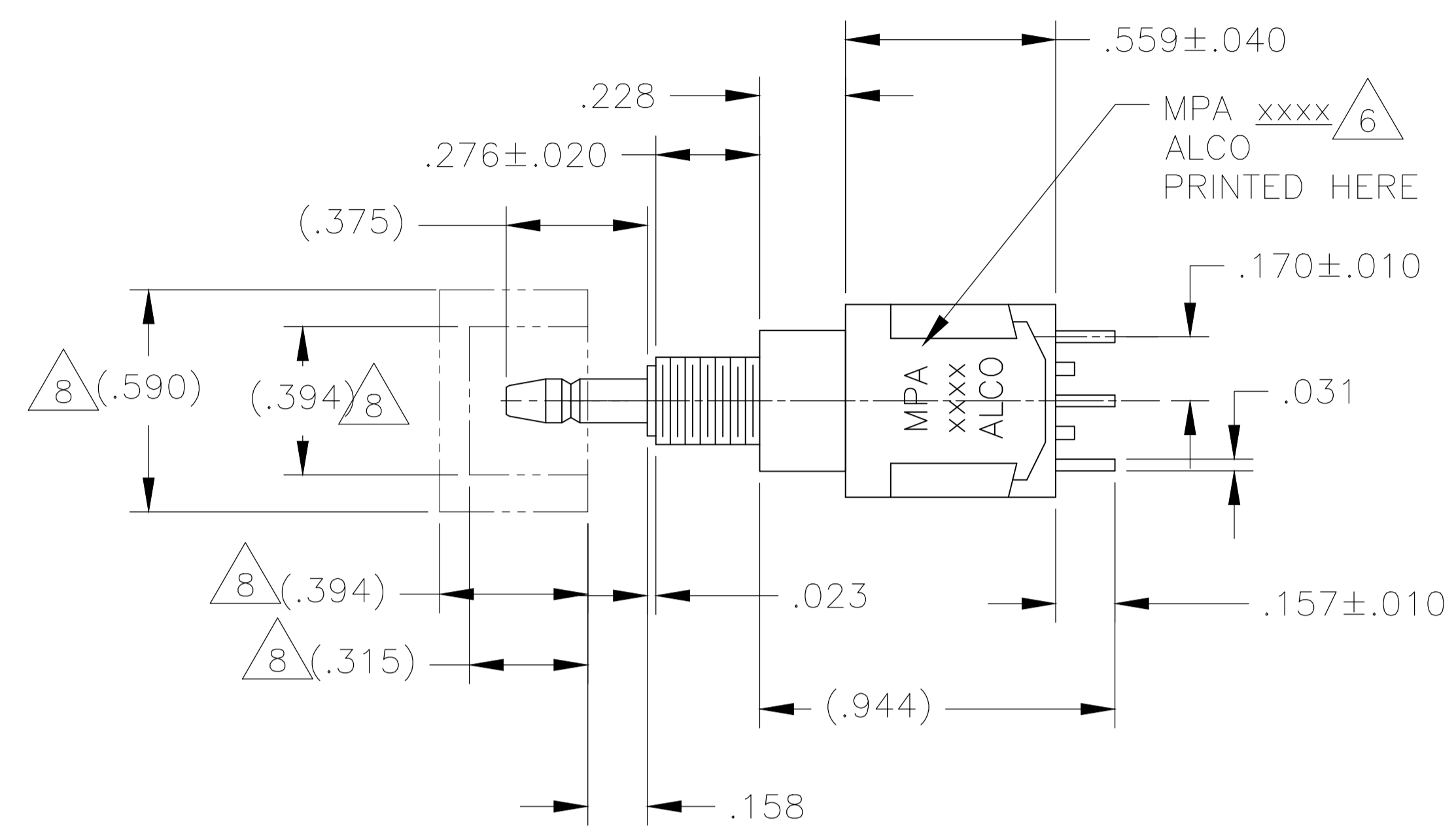

THIS DRAWING IS A CONTROLLED DOCUMENT.		DWN: M. BINNER 02MAR09	TE Connectivity Ltd.
DIMENSIONS: INCHES		CHK: M. ZITTO 15NOV04	
TOLERANCES UNLESS OTHERWISE SPECIFIED:		APVD: M. ZITTO 15NOV04	NAME: ALCOSWITCH GREEN SERIES PUSHBUTTON SWITCH, MPA SERIES
0 PLC ± -	1 PLC ± -	PRODUCT SPEC	SIZE: A1
2 PLC ± -	3 PLC ± .012	APPLICATION SPEC	CAGE CODE: 2-1437567-9
4 PLC ± -	ANGLES ± -	WEIGHT	RESTRICTED TO: -
MATERIAL: -	FINISH: -	CUSTOMER DRAWING	SCALE: 3:1
		SHEET: 3 OF 3	REV: A5

Mouser Electronics

Authorized Distributor

Click to View Pricing, Inventory, Delivery & Lifecycle Information:

[TE Connectivity:](#)

[MPA106D](#)



Correa para barbilla para cascos de seguridad Scator y Scator-E

Las correas para barbilla son el accesorio perfecto para nuestros cascos de seguridad industriales Scator (con ventilación) y Scator-E (sin ventilación).

Las correas para barbilla están especialmente diseñadas para su fijación a los cascos de seguridad Scator y Scator-E. Proporcionan seguridad adicional y garantizan que el casco de seguridad se asiente de forma aún más segura en la cabeza, incluso en caso de impactos y caída de objetos.

Las correas para barbilla se pueden ajustar individualmente para adaptarlas de forma óptima a la forma de la cabeza.

Tecnologías

- Correa para barbilla de horquilla con suspensión de 4 puntos y cierre rápido
- Accesorios de recambio para cascos de obra Scator (ventilados) y Scator-E (no ventilados)
- Divisor lateral (punto de ajuste)

Uso y aplicación

- Adecuadas para los cascos de seguridad ABUS Scator y Scator-E
- Las correas para barbilla proporcionan una protección adicional contra la caída de objetos y evitan que el casco resbale o se caiga durante el movimiento

Variantes

- Color: negro

Correa para barbilla Scator(-E)



Seite 2 von 2

Datos técnicos - Correa para barbilla Scator(-E)

Color de superficie	negro
Estándar	EN 397:2012 + A1:2012
Peso	15 g
Tamaño	universal
EAN	4003318948657

1037 CLOSING CLICK SYSTEM



ANNEX 5. TECHNICAL DRAWINGS

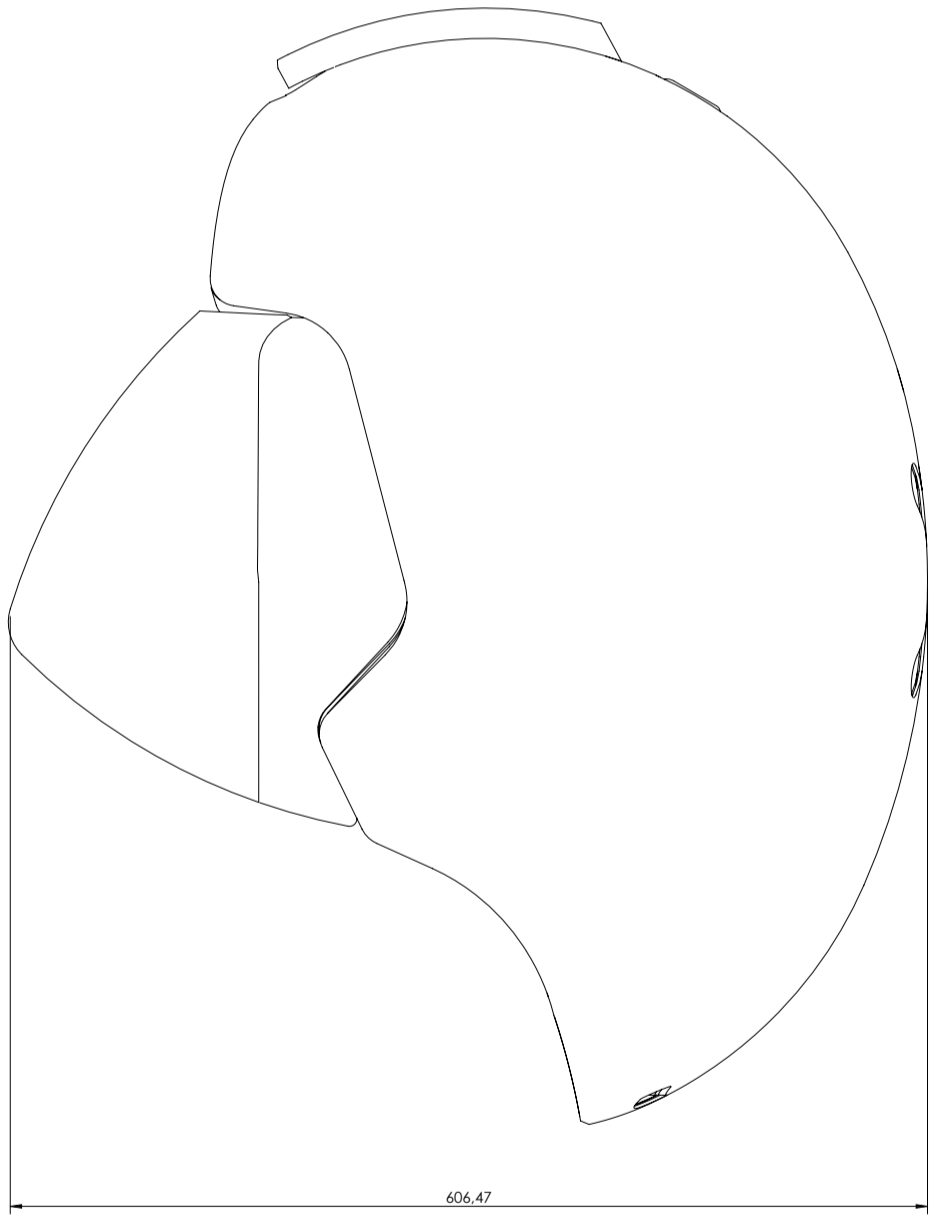
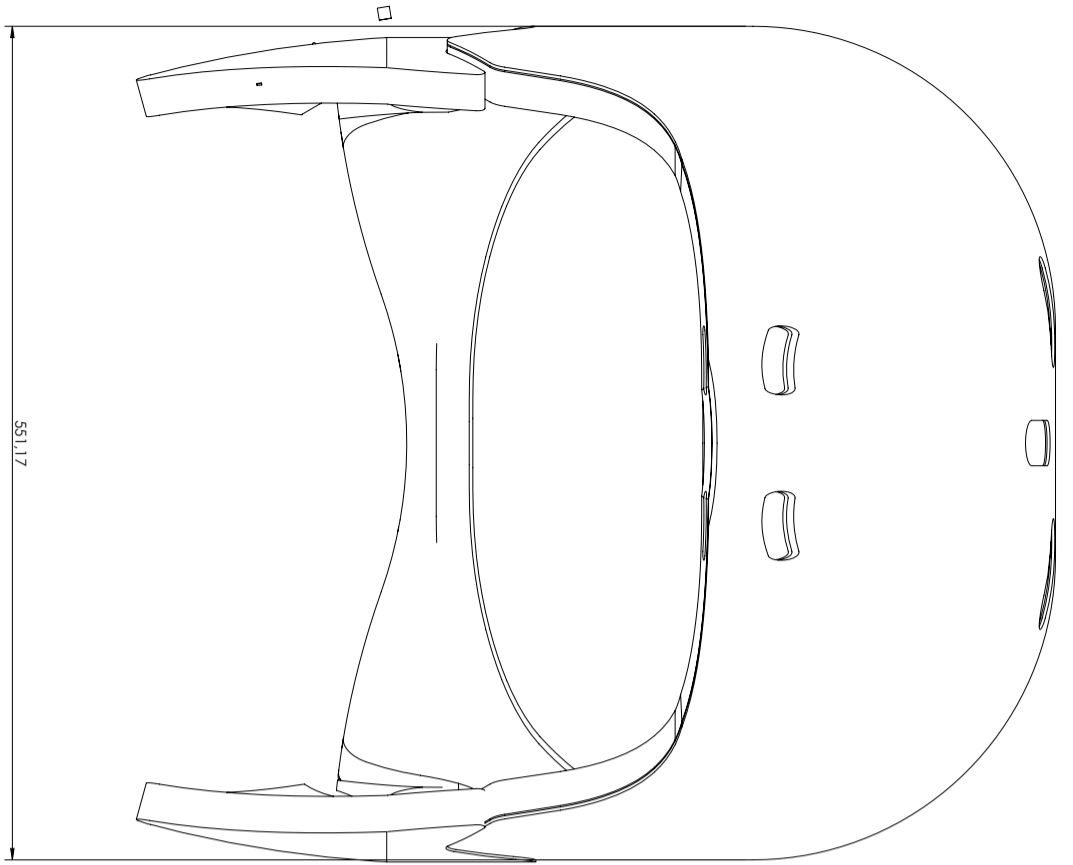
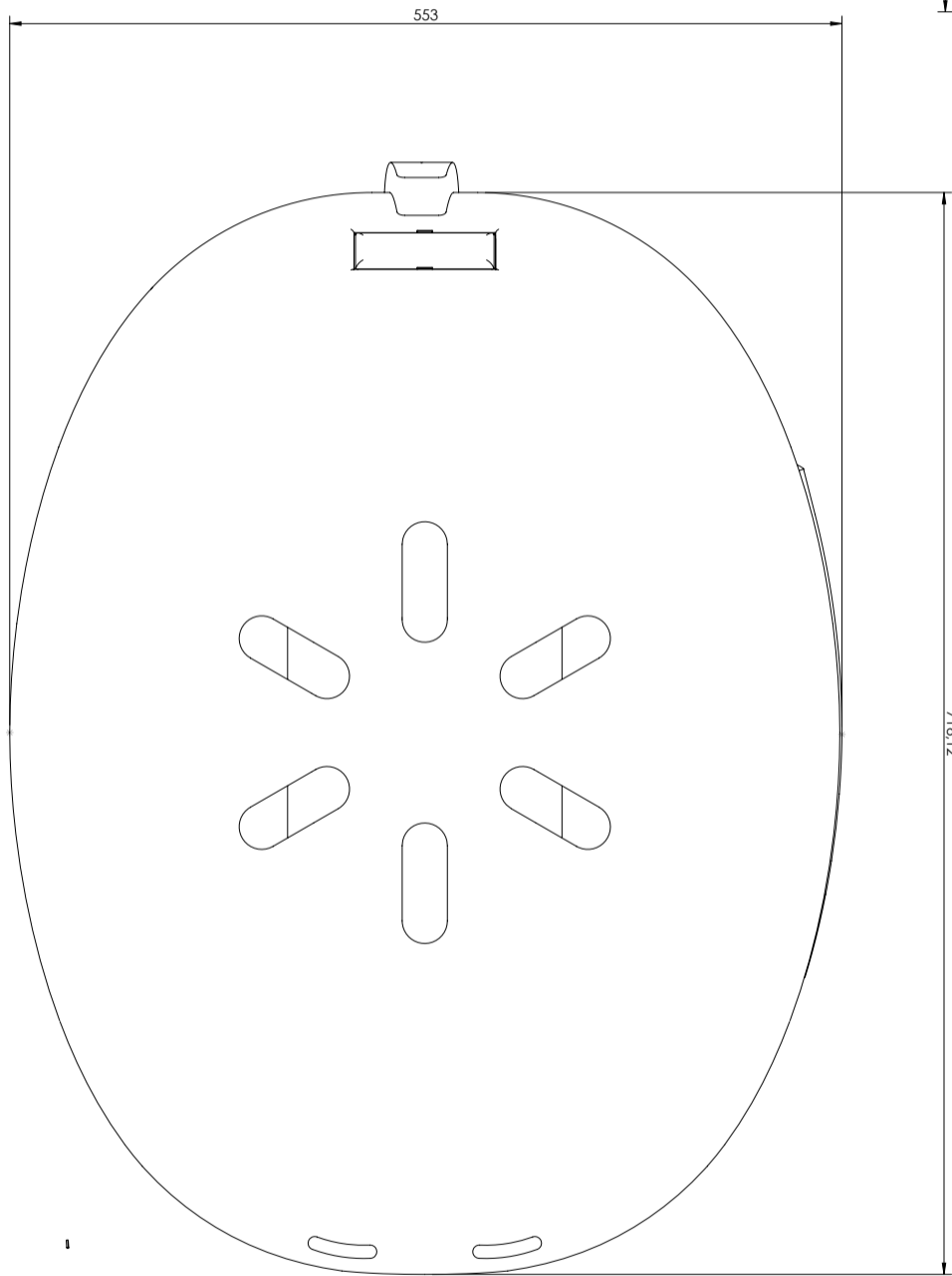

FOR MANUFACTURING

SCALE 1:5

1/5

Sheet:



POLITECNICO
MILANO 1863

Drawing number: AVB-10918840-DRW-SHD1120_1000_DFM

PROJECT NAME

SMART SKI HELMET: TECHNOLOGICAL
APPROACH TO WINTER SPORTS SAFETY

STUDENT: ANE VITERI BELZA

TUTOR: MATTEO ORESTE INGERAMO

1.0	2023-2024
Issue	ACADEMIC YEAR
Drawn: AVB	
Checked: MOI	
Approved: MOI	
Authorized: MOI	03/10/2024

UNLESS OTHERWISE SPECIFIED,
ALL DIMENSIONS ARE IN MM.

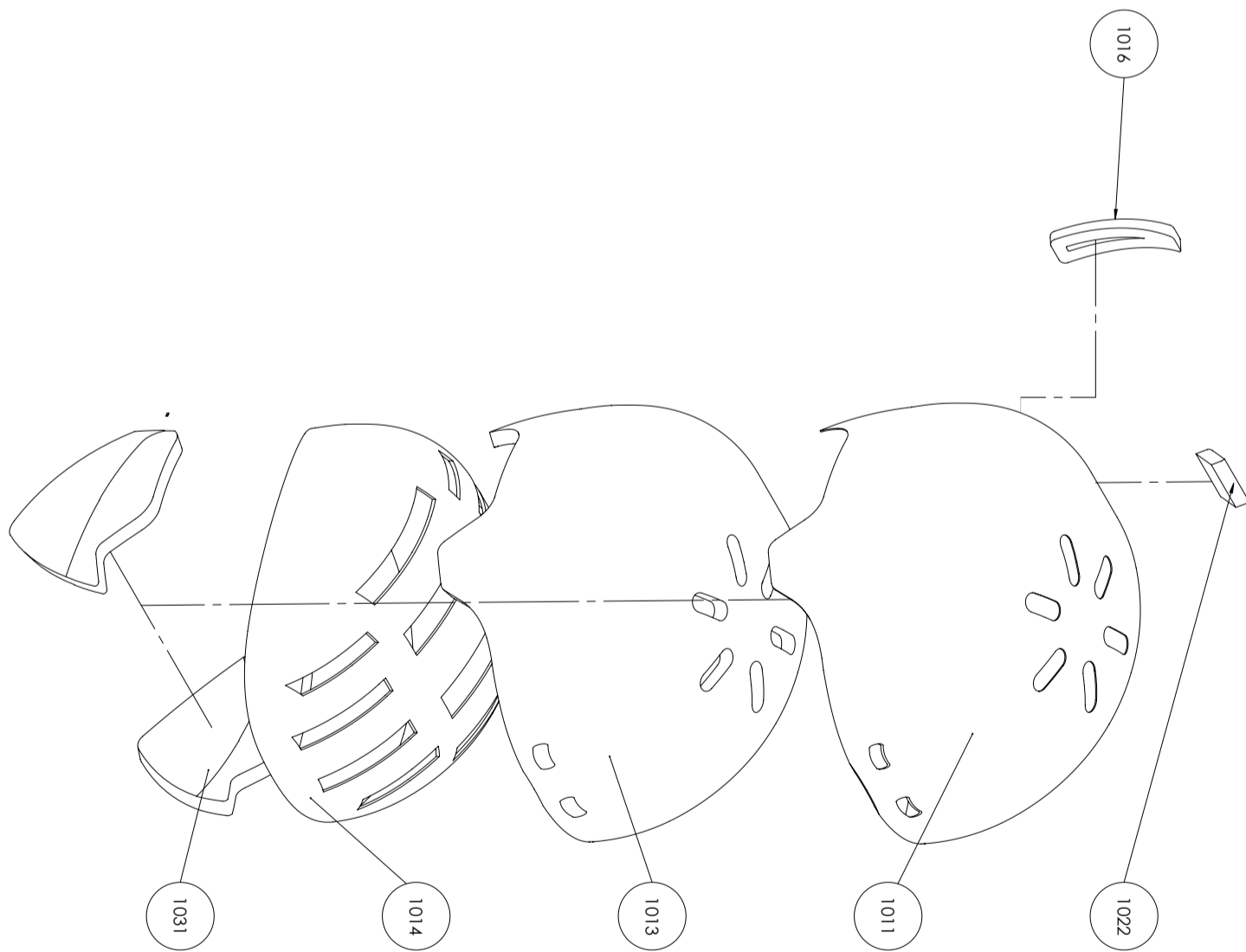
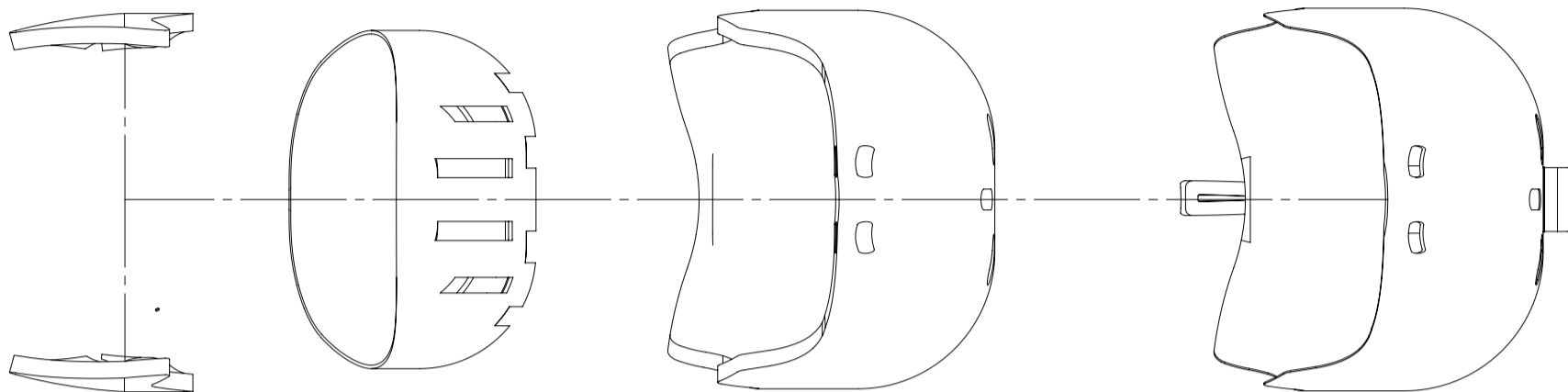

FOR MANUFACTURING

SCALE 1:10



POLITECNICO
MILANO 1863

Drawing number: AVB-10918840-DRW-SHD1120_1000_DFM

PROJECT NAME
SMART SKI HELMET: TECHNOLOGICAL
APPROACH TO WINTER SPORTS SAFETY

STUDENT: ANE VITERI BELZA
TUTOR: MATTEO ORESTE INGARAMO

1.0	2023-2024
Issue	ACADEMIC YEAR
Drawn: AVB	
Checked: MOI	
Approved: MOI	
Authorized: MOI	03/10/2024

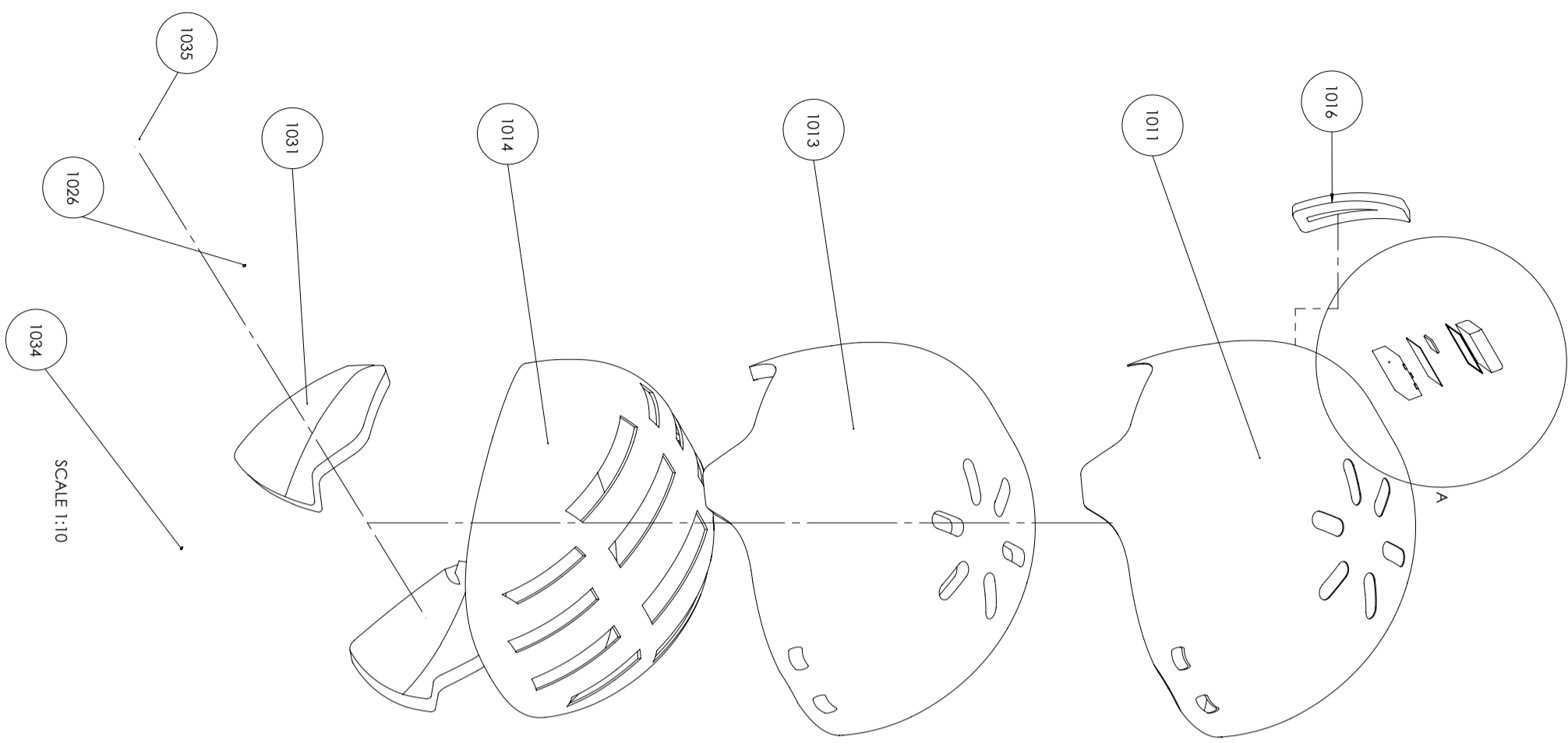

SCALE 1:10

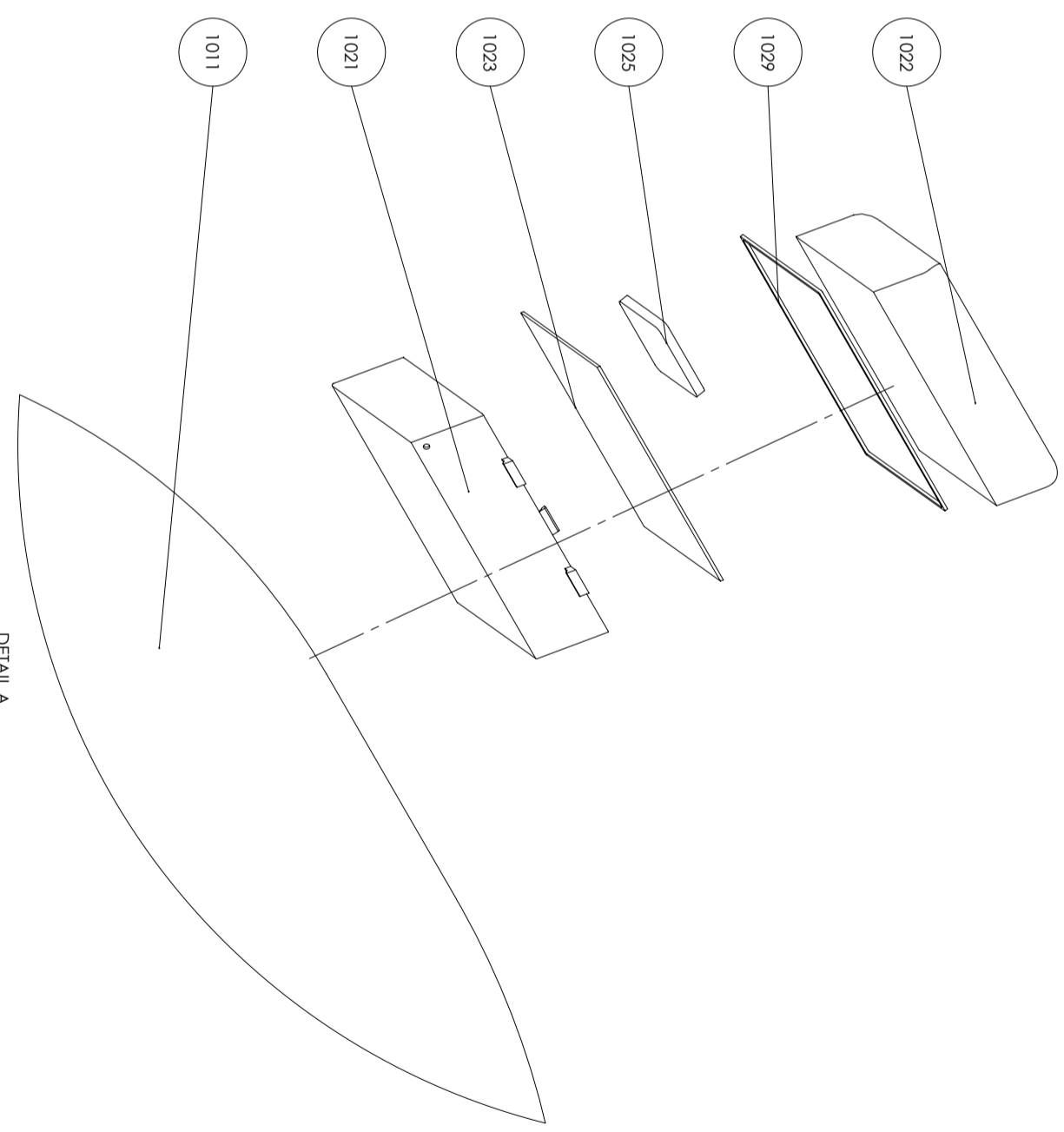

SCALE 1:2

DETAIL A

FOR MANUFACTURING



POLITECNICO
MILANO 1863

Drawing number: AVB-10918840-DRW-SHD1120_1000_DFM

PROJECT NAME
SMART SKI HELMET: TECHNOLOGICAL
APPROACH TO WINTER SPORTS SAFETY

STUDENT: ANE VITER BELZA
TUTOR: MATTEO ORESTE INGARAMO

1.0	2023-2024
Issue	ACADEMIC YEAR
Drawn: AVB	 <small>UNLESS OTHERWISE SPECIFIED, ALL DIMENSIONS ARE IN MM.</small>
Checked: MOI	
Approved: MOI	
Authorized: MOI	03/10/2024

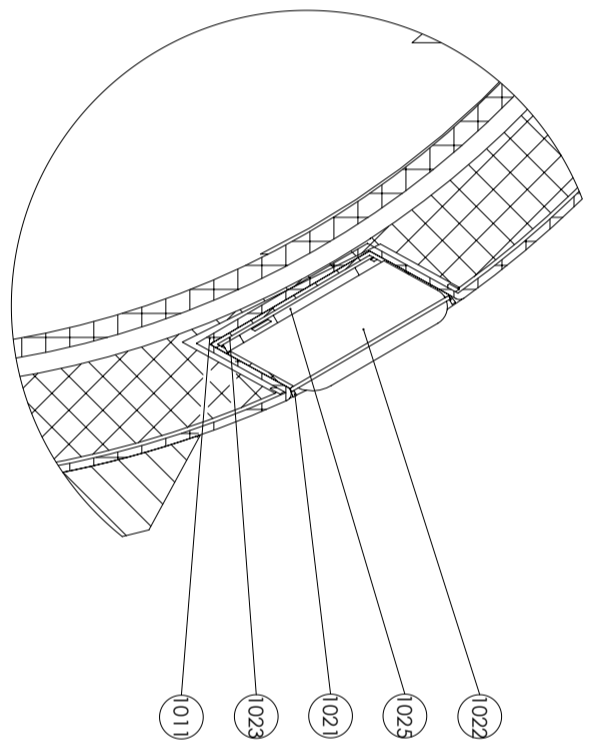
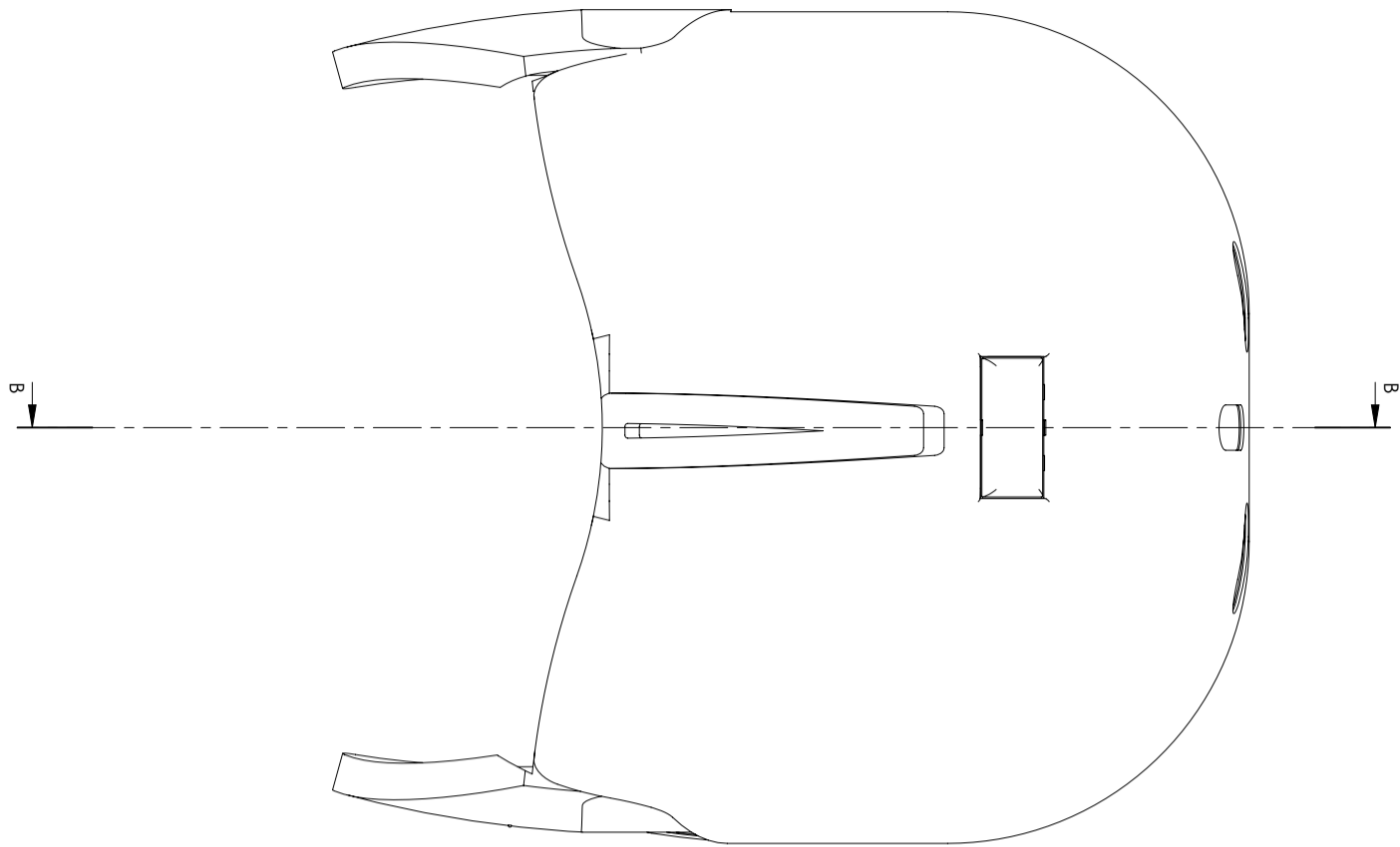

DETAIL C
SCALE 1:2

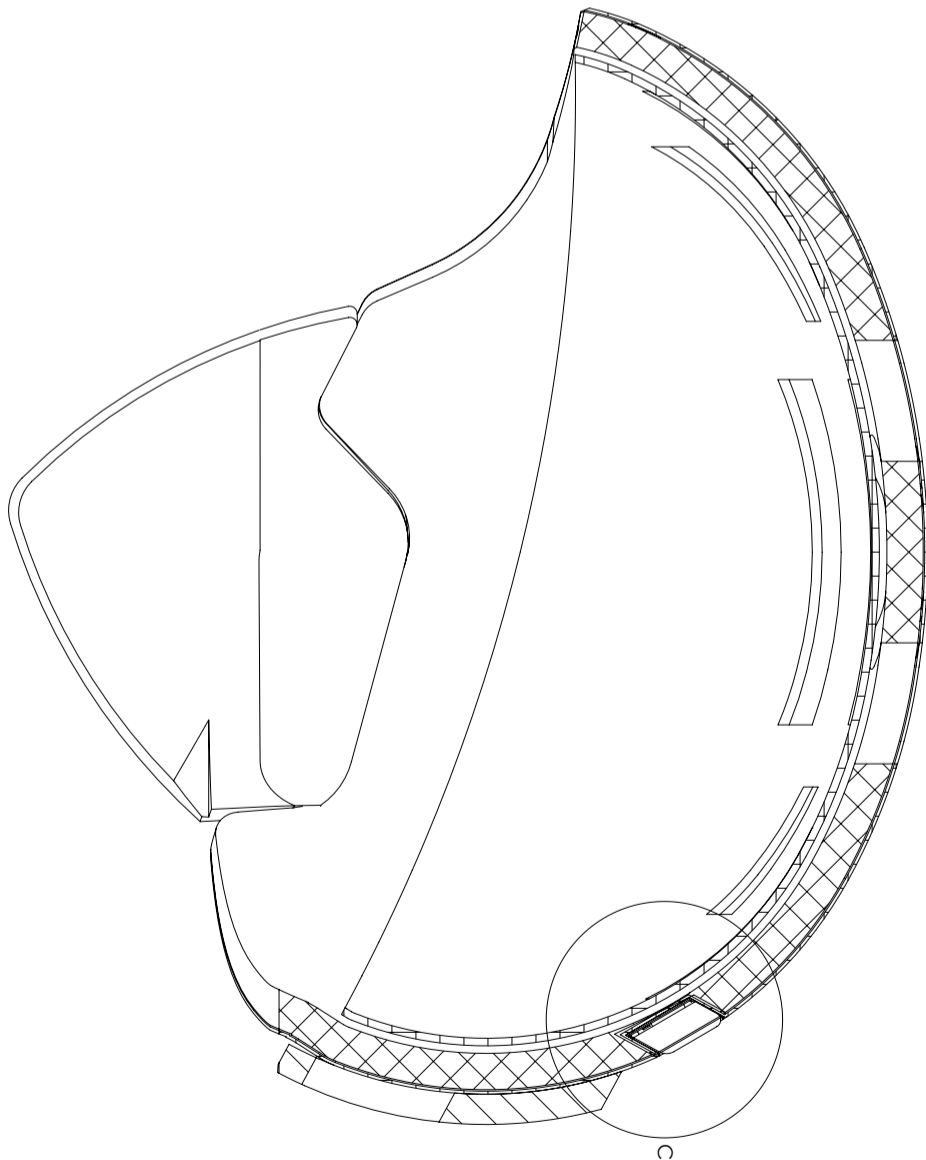

SECTION B-B

FOR MANUFACTURING

SCALE 1:5



1.0	2023-2024
Issue	ACADEMIC YEAR
Drawn: AVB	
Checked: MOI	
Approved: MOI	
Authorized: MOI	03/10/2024

ELEMENT NUM.	DESCRIPTION	MAKE OR BUY	DRAWING NAME	MATERIAL	QTY
1011	Helmet ABS/PC shell	MAKE	AVB-10918840-DRW-SHD1120_1011	ABS / PC	1
1013	Foam shell-MIPS	MAKE	AVB-10918840-DRW-SHD1120_1013	EPPS	1
1014	MIPS	MAKE	AVB-10918840-DRW-SHD1120_1014	PC	1
1016	Goggles arrangement	BUY	.	-	1
1021	LED light and electronics case	MAKE	AVB-10918840-DRW-SHD1120_1021	ABS / PC	1
1022	LED light	BUY	-	-	1
1023	PCB	BUY	-	-	1
1024	USB-C INPUT	BUY	.	-	1
1025	Rechargeable Battery	BUY	.	-	1
1026	IMPACT SENSOR	BUY	.	-	1
1028	Cable connector	BUY	.	-	2
1029	Rubber seal	BUY	-	-	1
1031	Earmuffs	MAKE	AVB-10918840-DRW-SHD1120_1031	PU	1
1033	MICROPHONE	BUY	.	-	1
1034	SPEAKER	BUY	.	-	1
1035	ON-OFF BUTTON	BUY	.	-	1

FOR MANUFACTURING

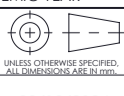
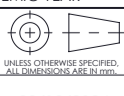
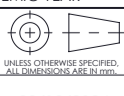
 POLITECNICO MILANO 1863	Drawing number: AVB-10918840-DRW-SHD1120_1000_DFM	STUDENT: ANE VITERI BELZA TUTOR: MATTEO ORESTE INGARAMO	<table border="1" style="width: 100%; border-collapse: collapse;"> <tr> <td style="text-align: center;">1.0</td> <td style="text-align: center;">2023-2024</td> </tr> <tr> <td style="text-align: center;">Issue</td> <td style="text-align: center;">ACADEMIC YEAR</td> </tr> <tr> <td>Drawn: AVB</td> <td rowspan="4" style="text-align: center;">  </td> </tr> <tr> <td>Checked: MOI</td> </tr> <tr> <td>Approved: MOI</td> </tr> <tr> <td>Authorized: MOI</td> </tr> <tr> <td colspan="2" style="text-align: right;"> <small>UNLESS OTHERWISE SPECIFIED, ALL DIMENSIONS ARE IN mm.</small> 03/10/2024 </td> </tr> </table>	1.0	2023-2024	Issue	ACADEMIC YEAR	Drawn: AVB		Checked: MOI	Approved: MOI	Authorized: MOI	<small>UNLESS OTHERWISE SPECIFIED, ALL DIMENSIONS ARE IN mm.</small> 03/10/2024	
	1.0		2023-2024											
Issue	ACADEMIC YEAR													
Drawn: AVB														
Checked: MOI														
Approved: MOI														
Authorized: MOI														
<small>UNLESS OTHERWISE SPECIFIED, ALL DIMENSIONS ARE IN mm.</small> 03/10/2024														
PROJECT NAME SMART SKI HELMET: TECHNOLOGICAL APPROACH TO WINTER SPORTS SAFETY	Sheet: 5/5													

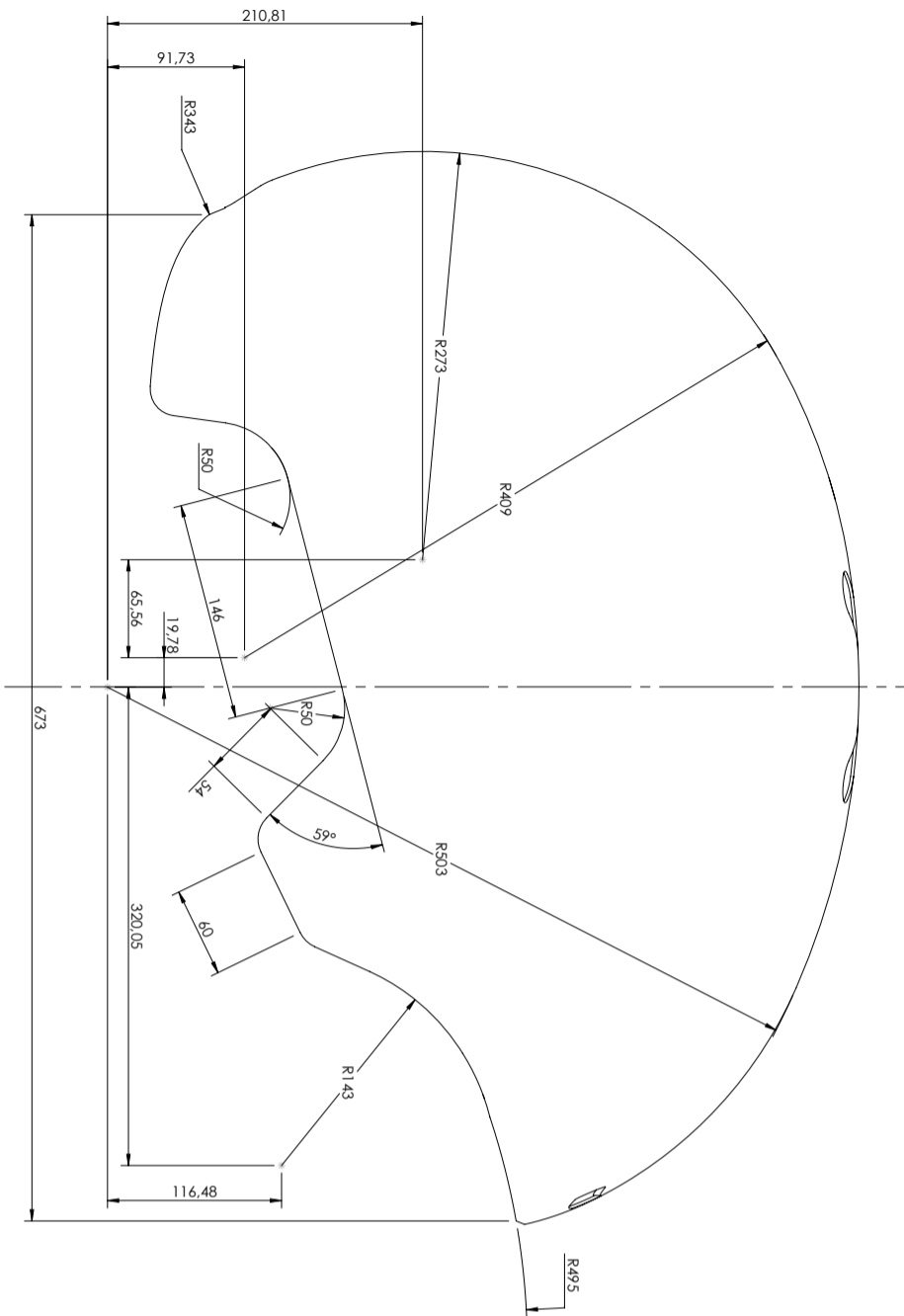

DETAIL B
SCALE 1:1

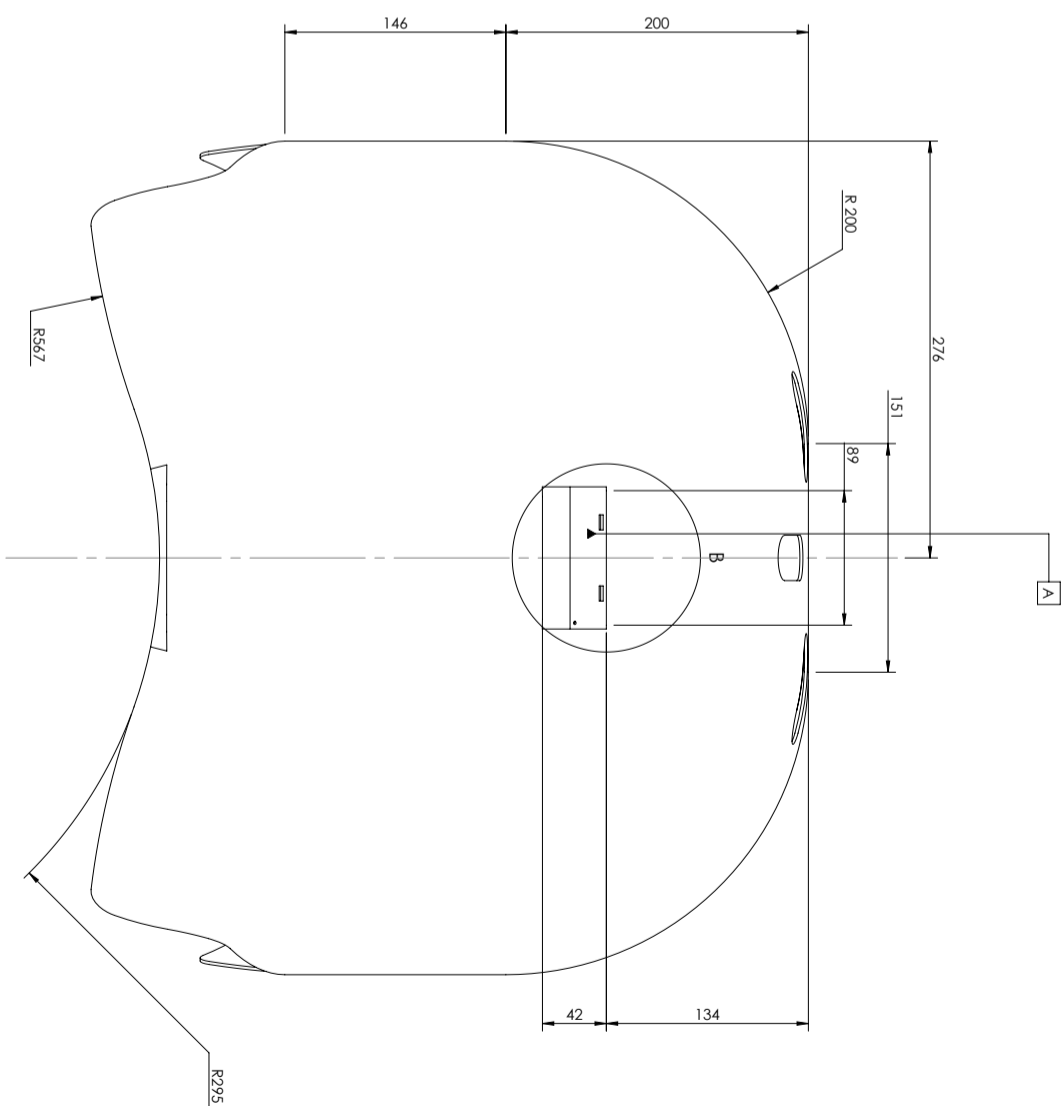
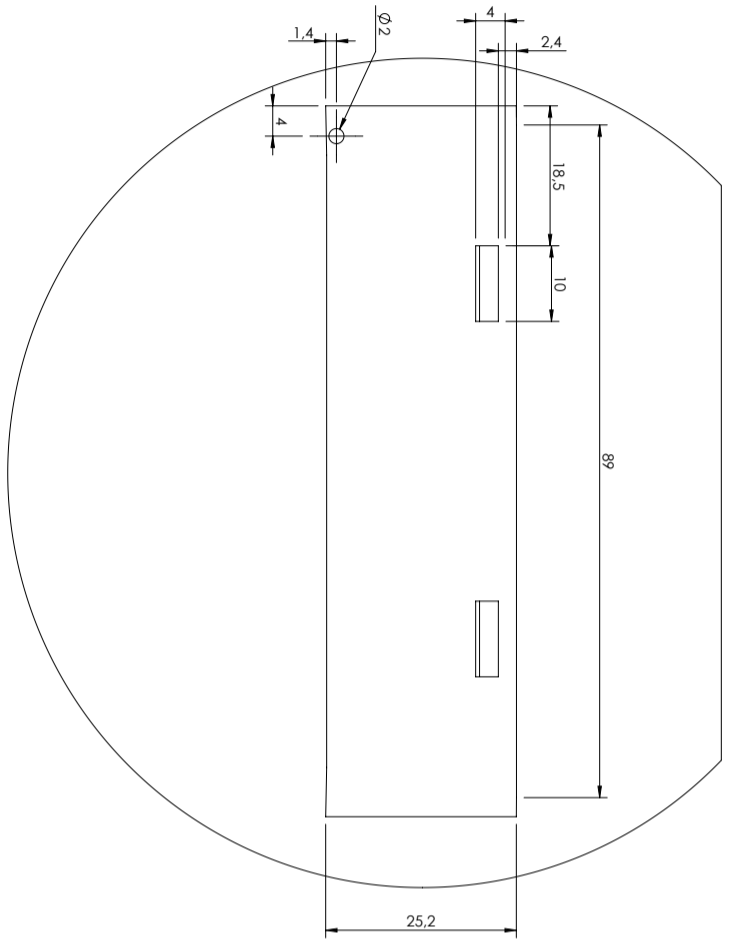

REFERENCE VIEW FROM A
SCALE 1:10

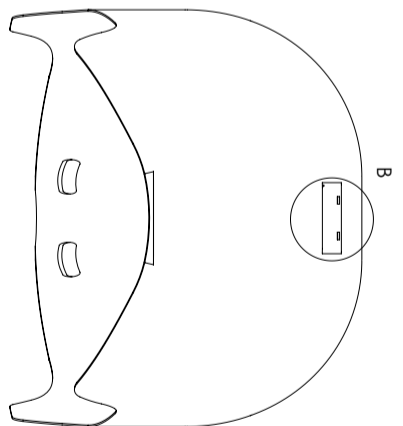

THICKNESS OF PART = 5MM
SCALE 1:5

FOR MANUFACTURING

Drawing number: AVB-10918840-DRW-SHD1120_1011

PROJECT NAME

**SMART SKI HELMET: TECHNOLOGICAL
APPROACH TO WINTER SPORTS SAFETY**

STUDENT: ANE VITERI BELZA
TUTOR: MATTEO ORESTE INGARAMO

1.0 2023-2024

Issue ACADEMIC YEAR

Drawn: AVB

Checked: MOI

Approved: MOI

Authorized: MOI



UNLESS OTHERWISE SPECIFIED,
ALL DIMENSIONS ARE IN MM.

03/10/2024



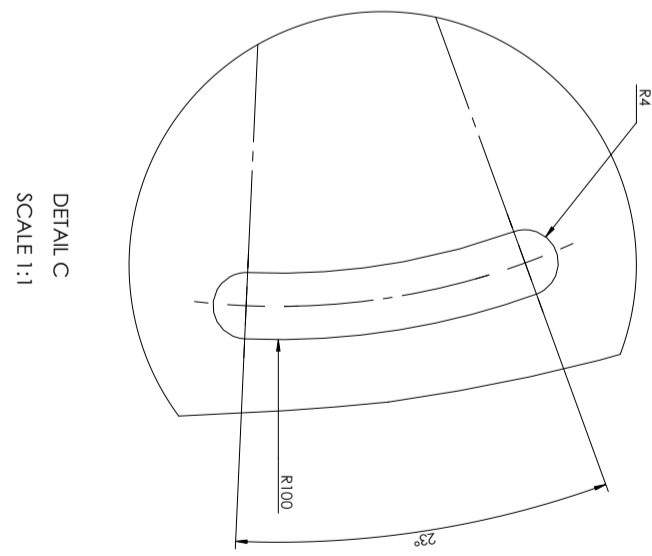
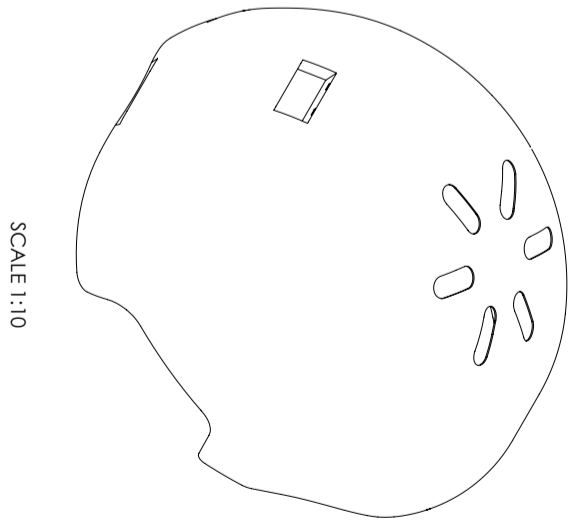
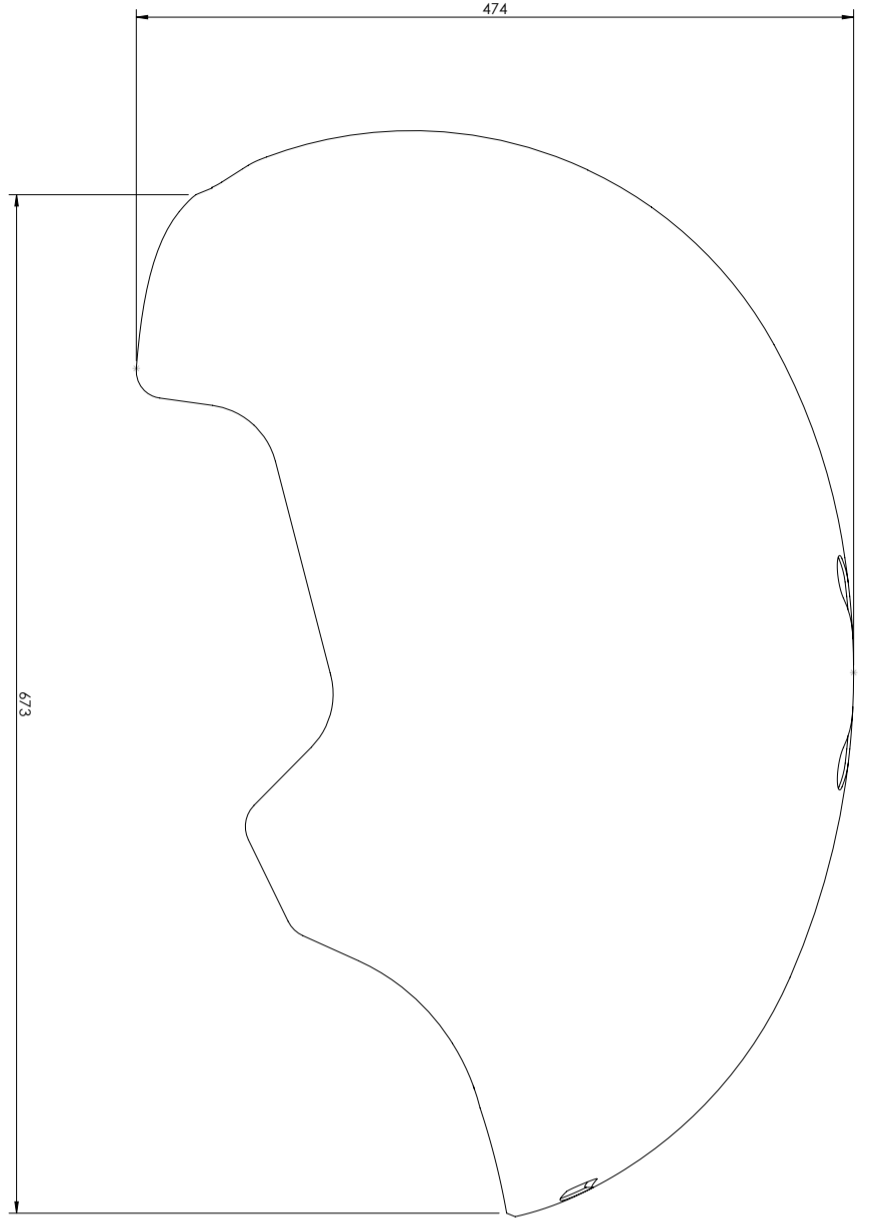
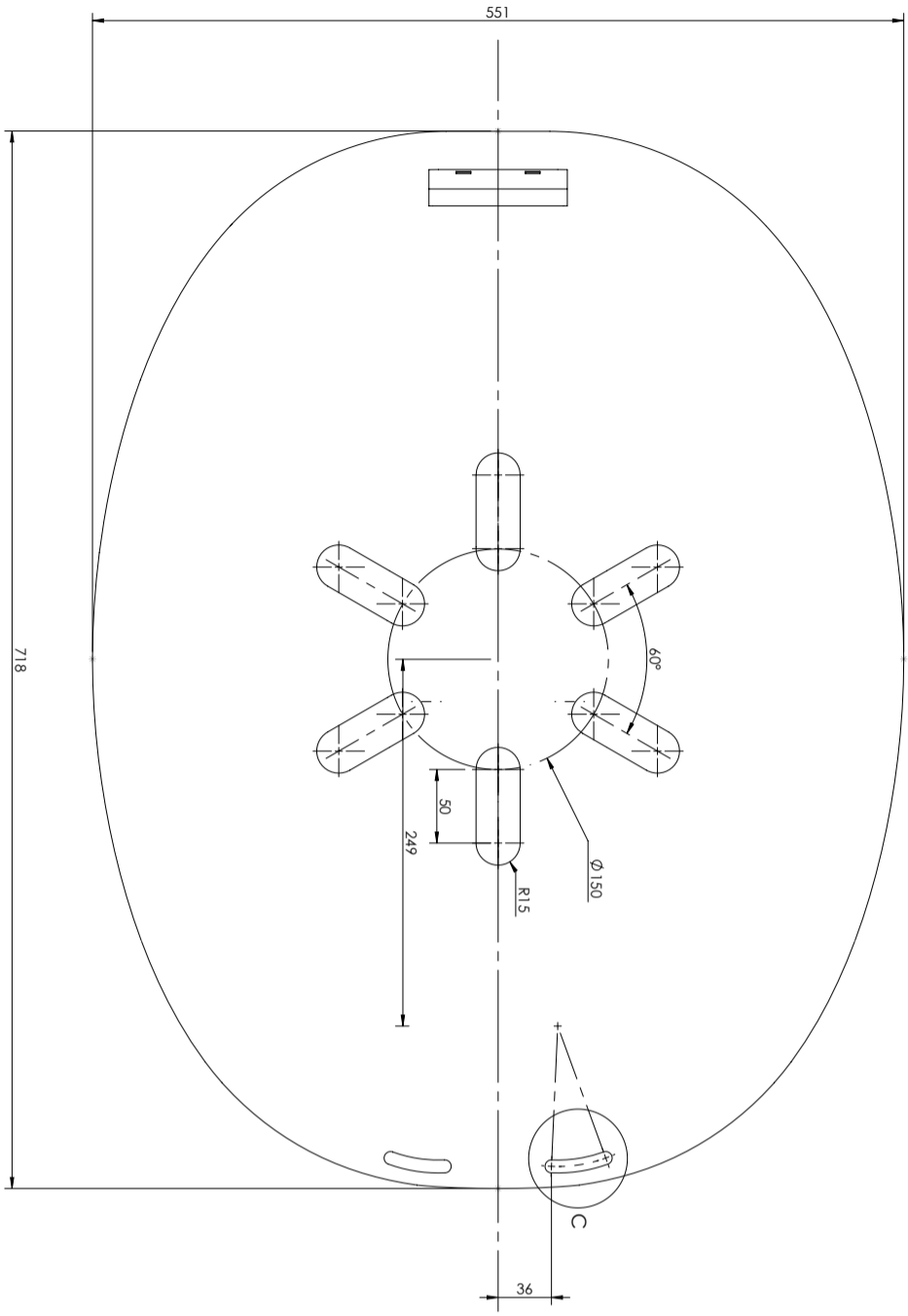

FOR MANUFACTURING

SCALE 1:5



POLITECNICO MILANO 1863

Drawing number: AVB-10918840-DRW-SHD1120_1011_DFM
DRAWING NUMBER
SMART SKI HELMET: A TECHNOLOGICAL APPROACH TO WINTER SPORTS SAFETY

STUDENT: AN VITERI BELZA
TUTOR: MATTEO ORESTE INGARAMO

1.0	2023-2024
Issue	ACADEMIC YEAR
Drawn: AVB	
Checked: MOI	
Approved: MOI	
Authorized: MOI	03/10/2024

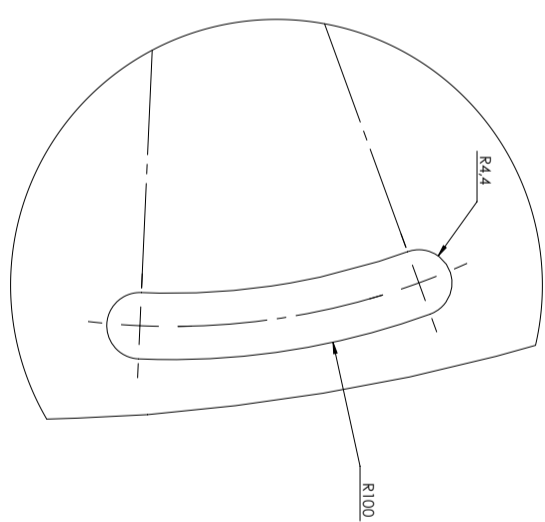
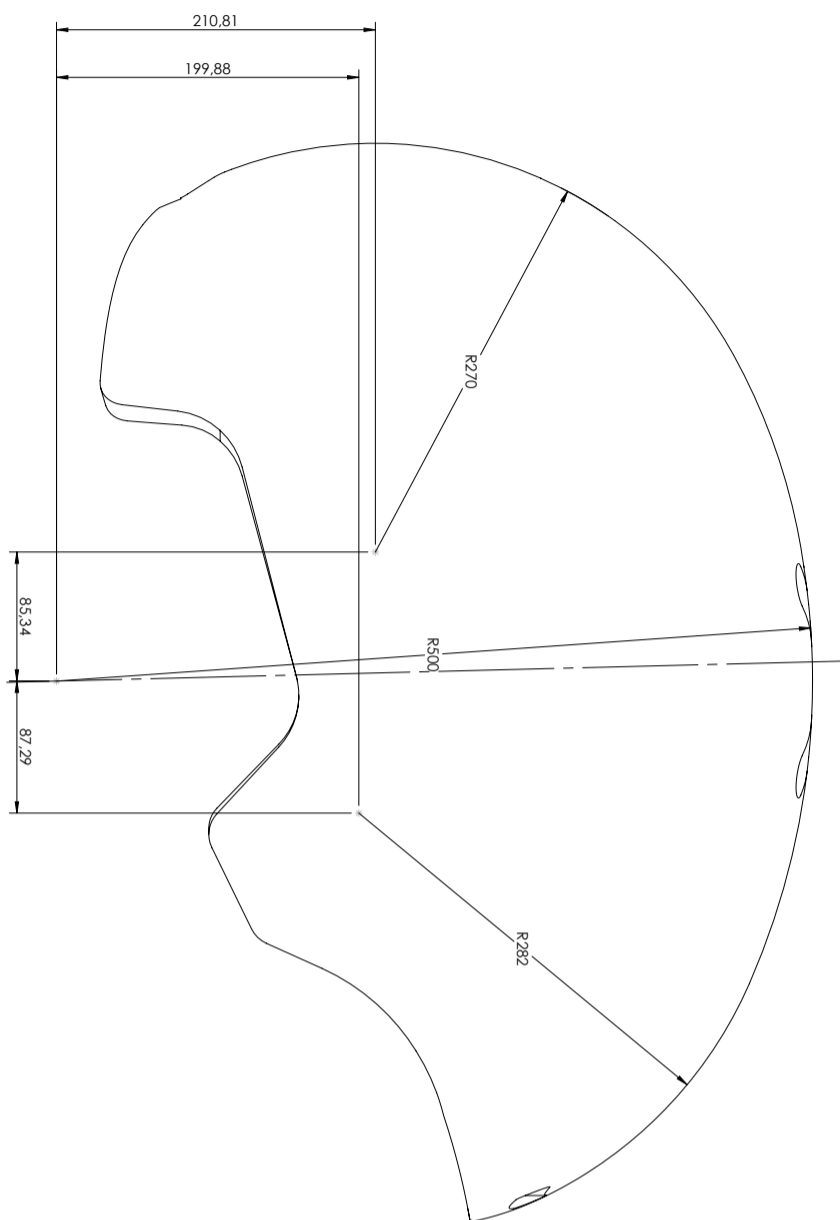
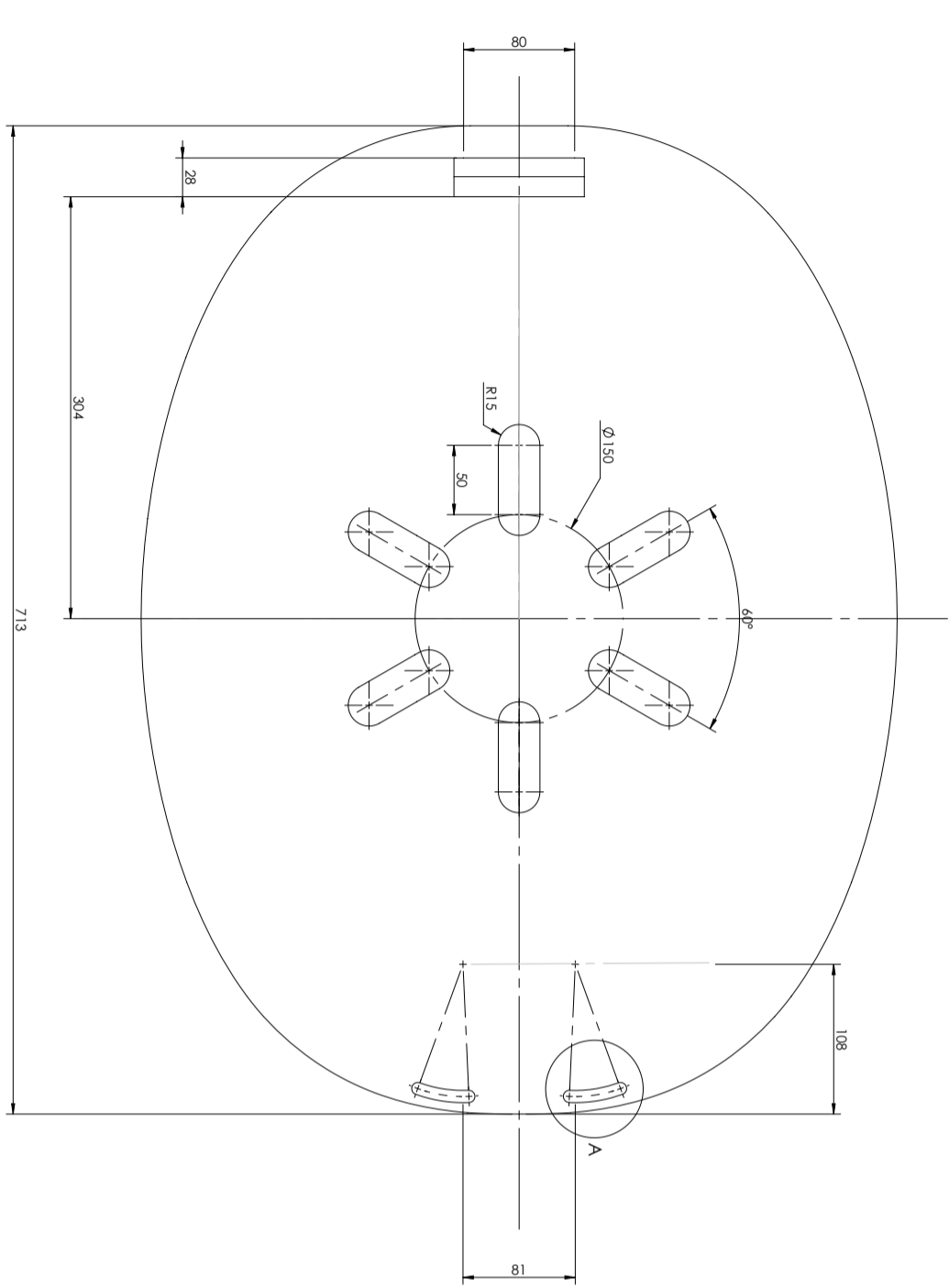

DETAIL A
SCALE 1:1

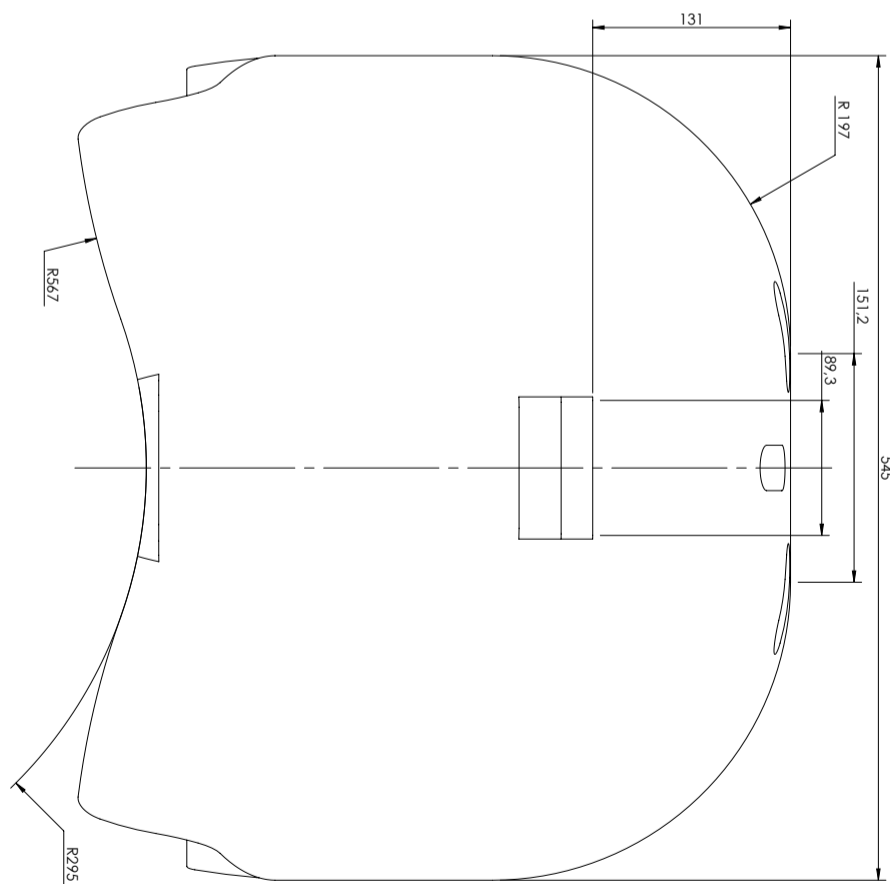

THICKNESS OF FOAM = 25MM
SCALE 1:5

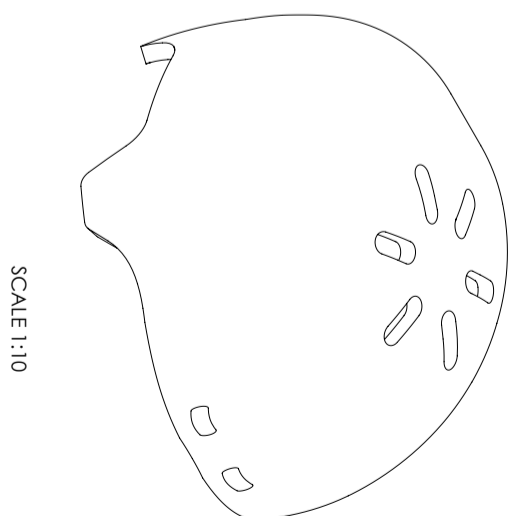

SCALE 1:10

FOR MANUFACTURING

Drawing number: AVB-10918840-DRW-SHD1120_1031_DFM

PROJECT NAME
SMART SKI HELMET: TECHNOLOGICAL APPROACH TO WINTER SPORTS SAFETY

STUDENT: ANE VITERI BELZA
TUTOR: MATTEO ORESTE INGARAMO

1.0	2024-2025
Issue	ACADEMIC YEAR
Drawn: AVB	
Checked: MOI	
Approved: MOI	
Authorized: MOI	03/10/2024



POLITECNICO
MILANO 1863

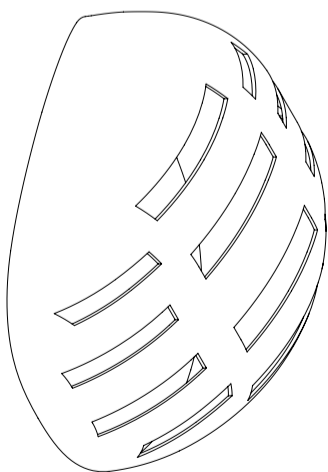
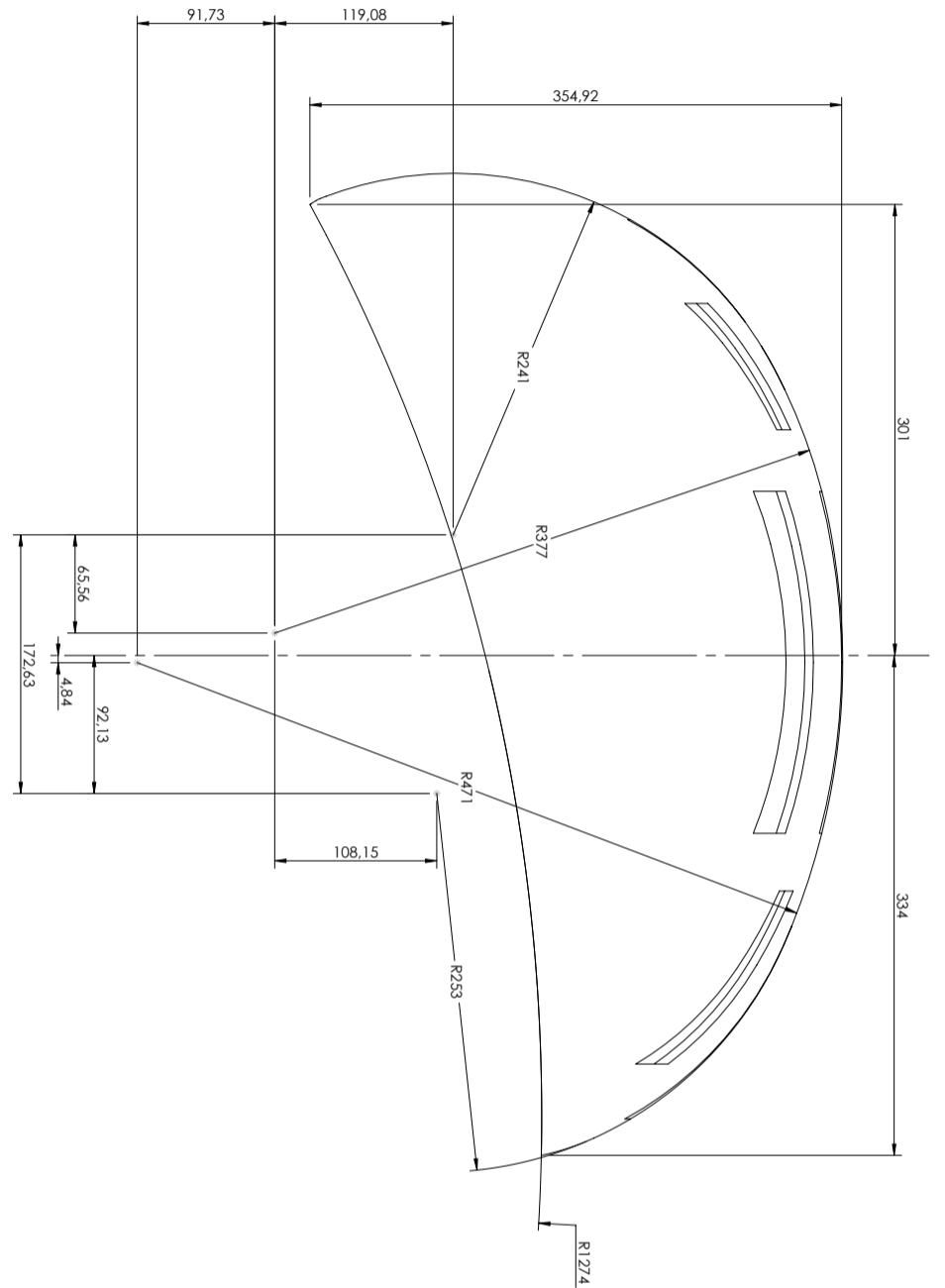
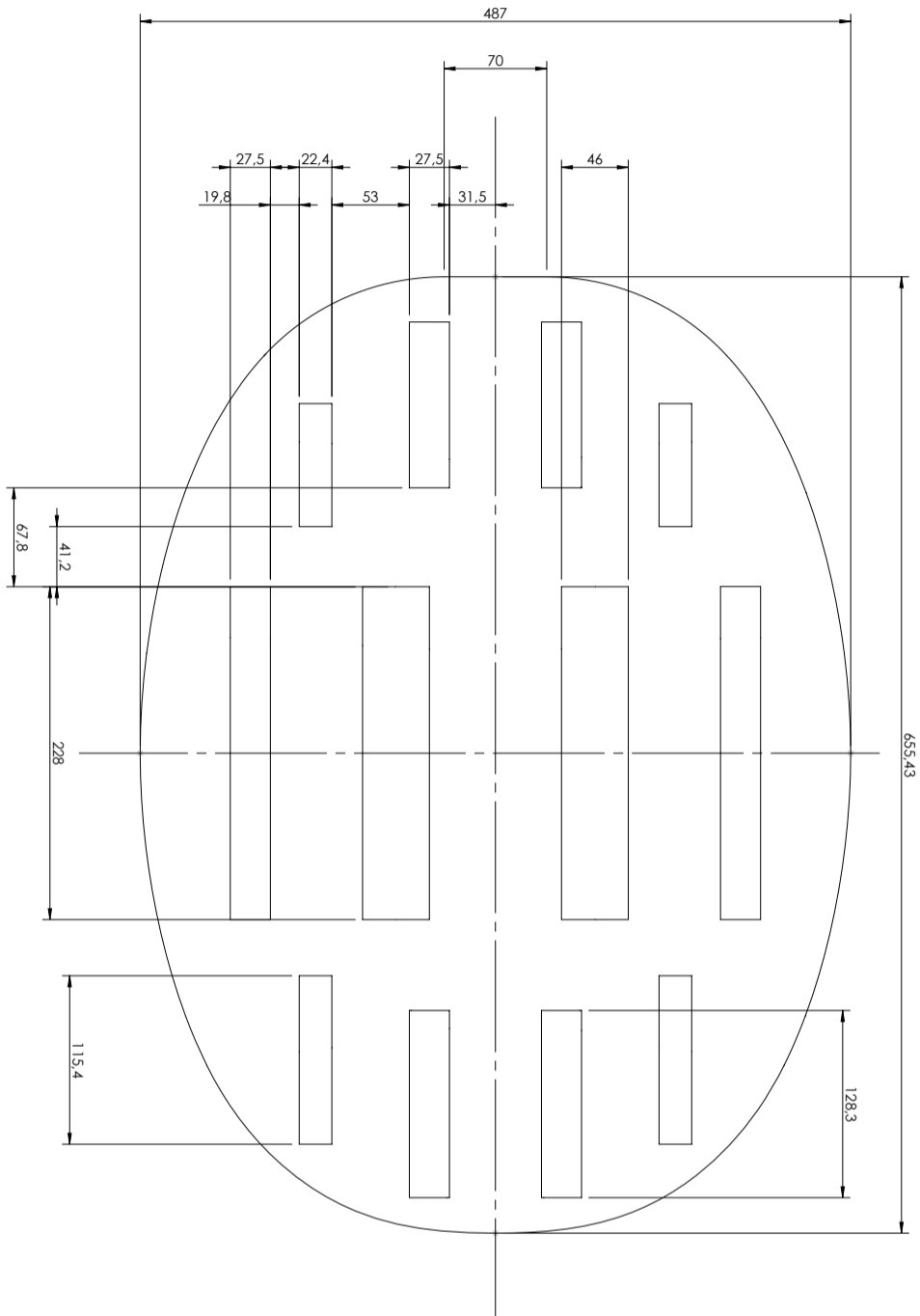

SCALE 1:10

FOR MANUFACTURING

THICKNESS OF MIPS SHELL = 5MM
SCALE 1:5

Drawing number: AVB-10918840-DRW-SHD1120_1014

PROJECT NAME

**SMART SKI HELMET: TECHNOLOGICAL
APPROACH TO WINTER SPORTS SAFETY**

STUDENT: ANE VITERI BELZA
TUTOR: MATTEO ORESTE INGARAMO

1.0	2023-2024
Issue	ACADEMIC YEAR
Drawn: AVB	
Checked: MOI	
Approved: MOI	
Authorized: MOI	03/10/2024



Sheet:
1/1

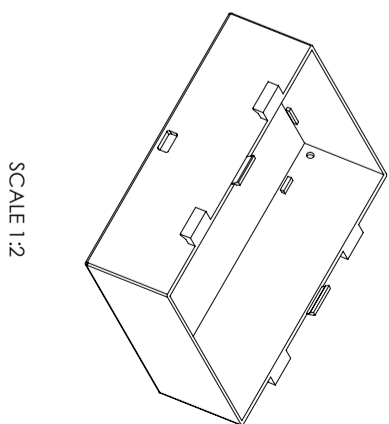
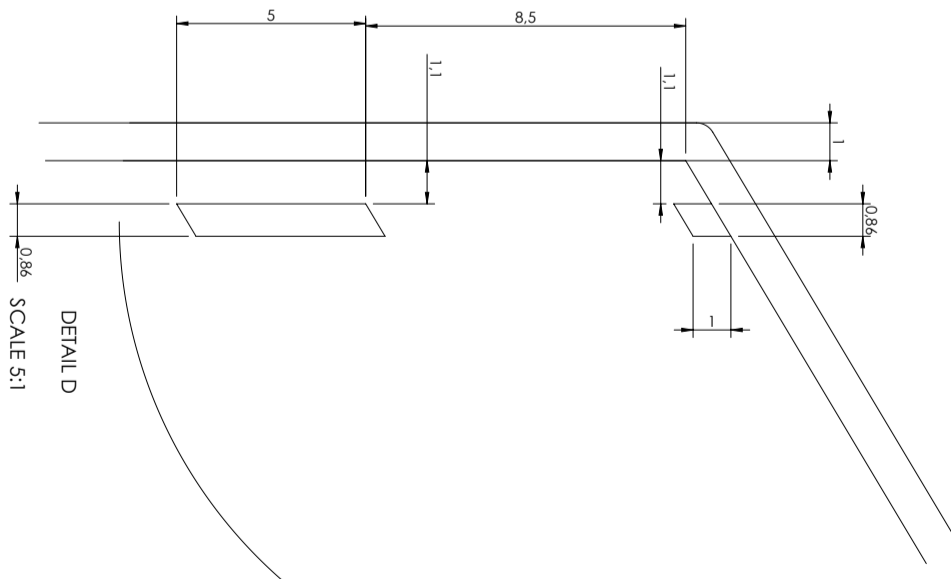
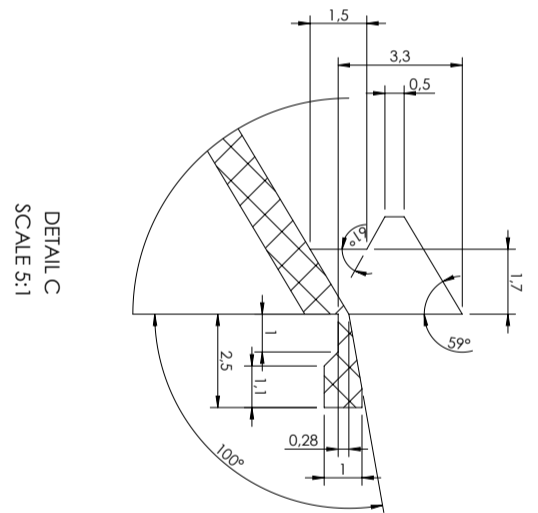
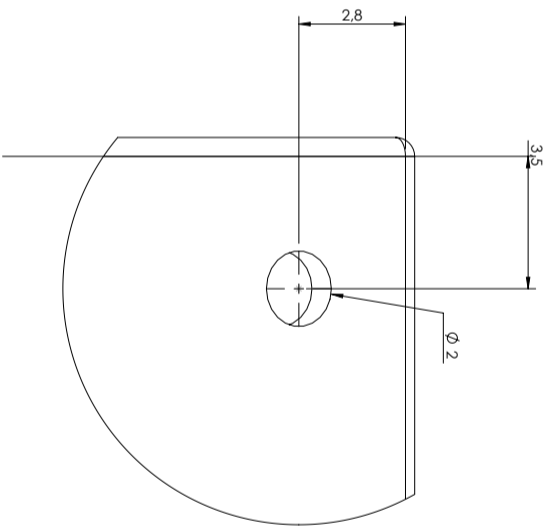
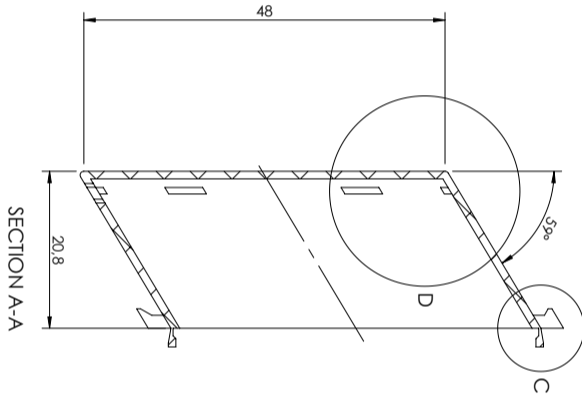
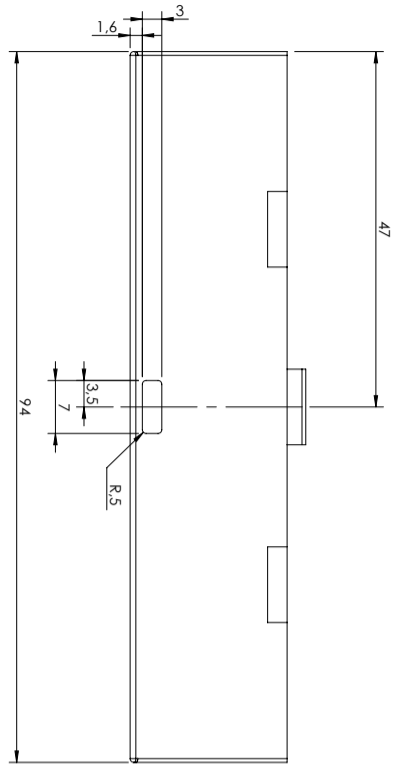
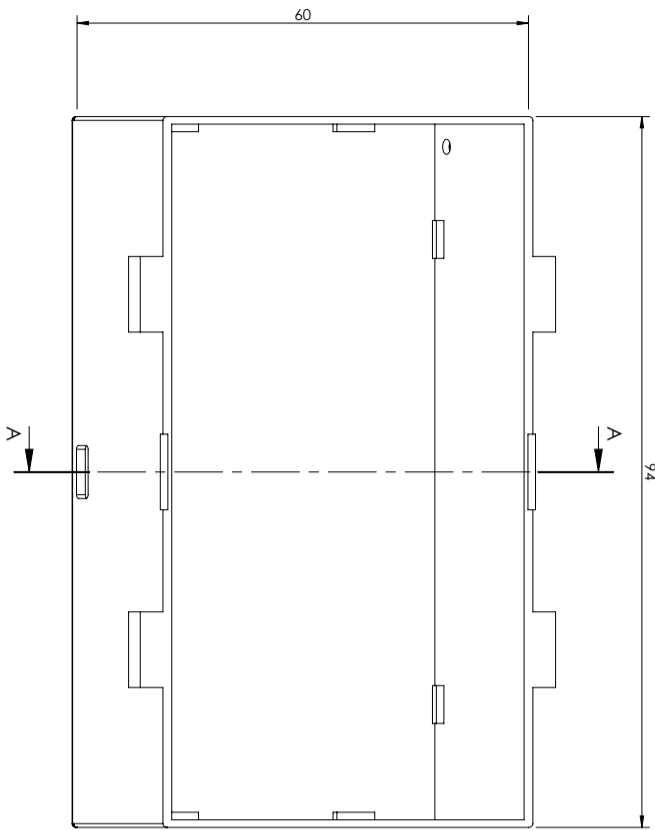
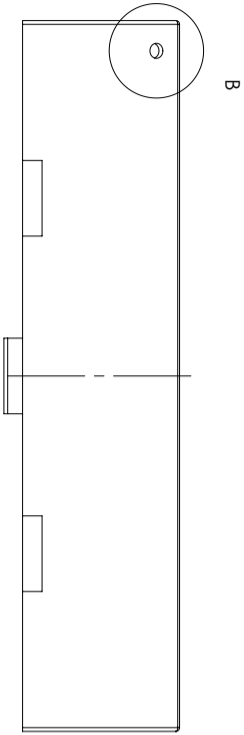

DETAIL B
SCALE 5:1

DETAIL C
SCALE 5:1

DETAIL D
SCALE 5:1

SCALE 1:1

FOR MANUFACTURING



POLITECNICO
MILANO 1863

Drawing number: AVB-10918840-DRW-SHD1120_1021_DFM

PROJECT NAME

SMART SKI HELMET: TECHNOLOGICAL
APPROACH TO WINTER SPORTS SAFETY

STUDENT: ANE VITERI BELZA
TUTOR: MATTEO ORESTE INGARAMO

1.0	2023-2024
Issue	ACADEMIC YEAR
Drawn: AVB	
Checked: MOI	
Approved: MOI	
Authorized: MOI	03/10/2024

UNLESS OTHERWISE SPECIFIED,
ALL DIMENSIONS ARE IN MM.

FOR MANUFACTURING

SCALE 1:2

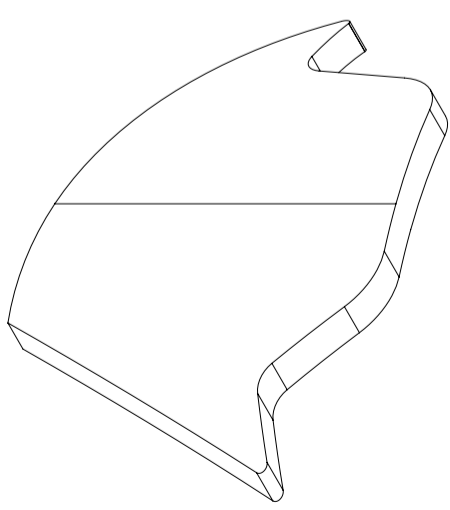
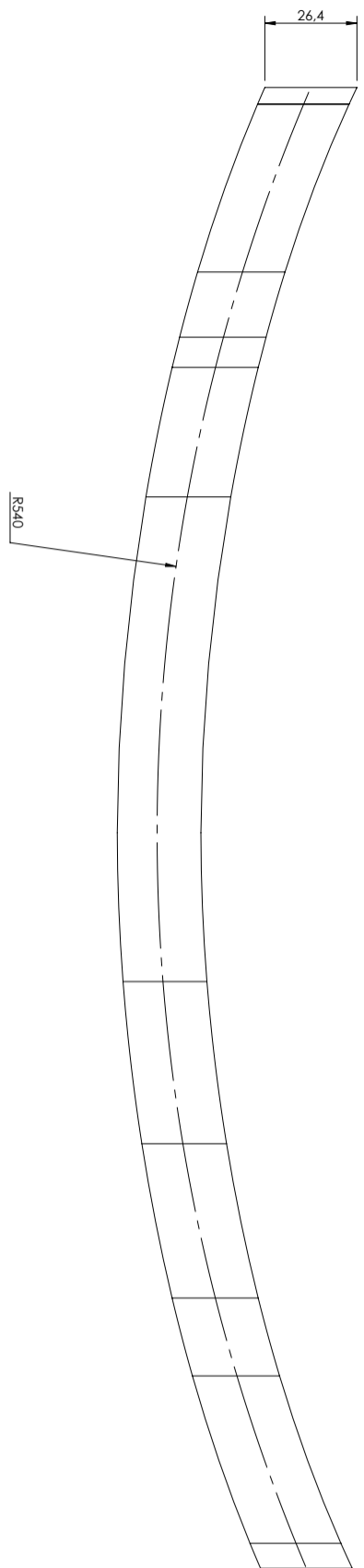
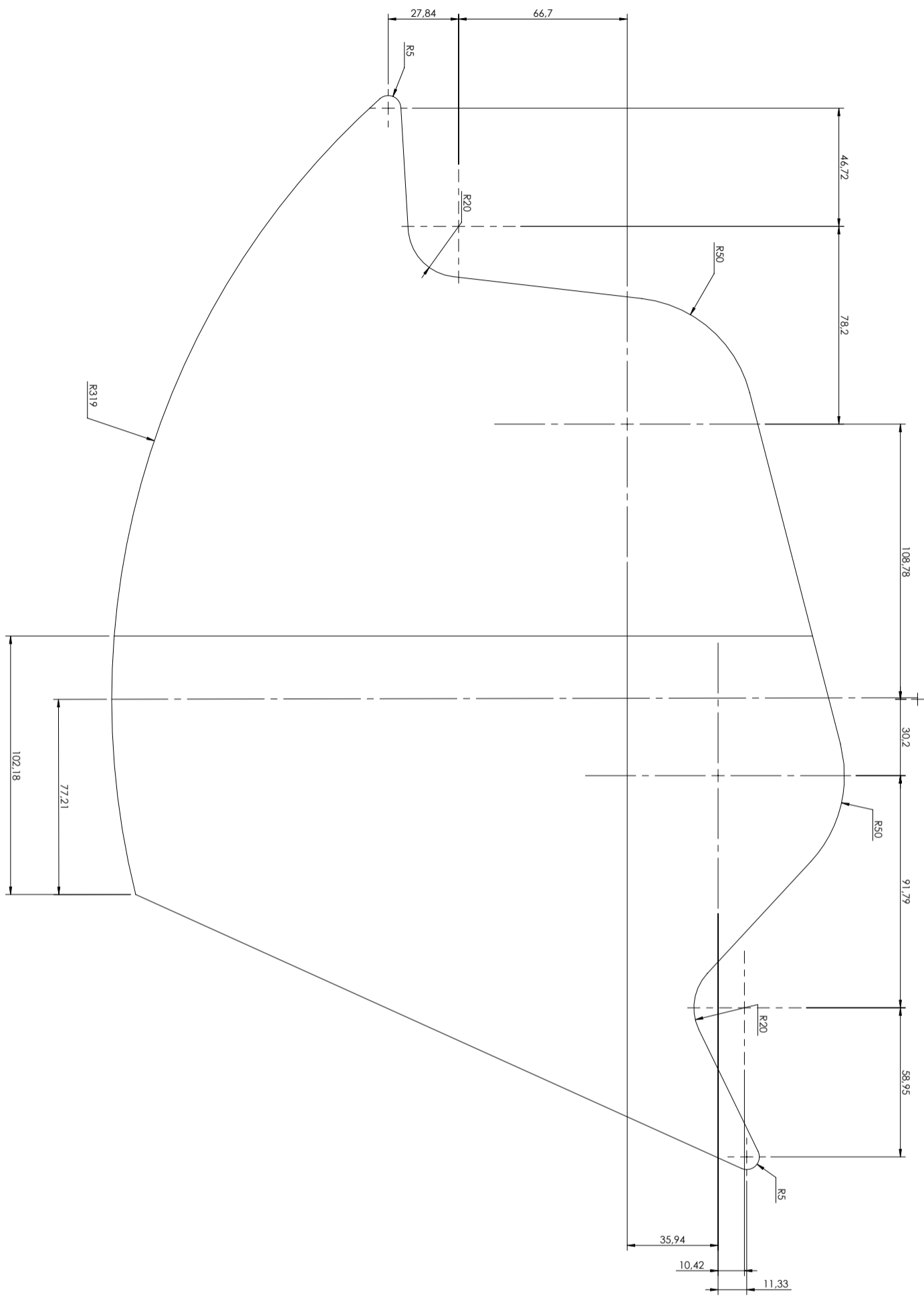

SCALE 1:5

1/1



POLITECNICO
MILANO 1863

Drawing number: AVB-10918840-DRW-SHD1120_1031_DFM

PROJECT NAME

**SMART SKI HELMET: TECHNOLOGICAL
APPROACH TO WINTER SPORTS SAFETY**

STUDENT: ANE VITERI BELZA
TUTOR: MATTEO ORESTE INGARAMO

1.0	2023-2024
Issue	ACADEMIC YEAR
Drawn: AVB	
Checked: MOI	
Approved: MOI	
Authorized: MOI	
<small>UNLESS OTHERWISE SPECIFIED, ALL DIMENSIONS ARE IN mm.</small>	
03/10/2024	

ANNEX 6. PROJECT GANTT

