

Board I Territorial Analysis of GANGTOU Village

Location and territorial

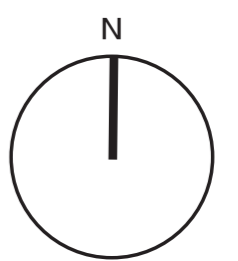

Legend:

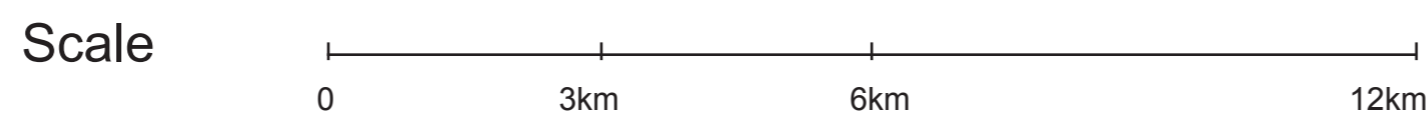
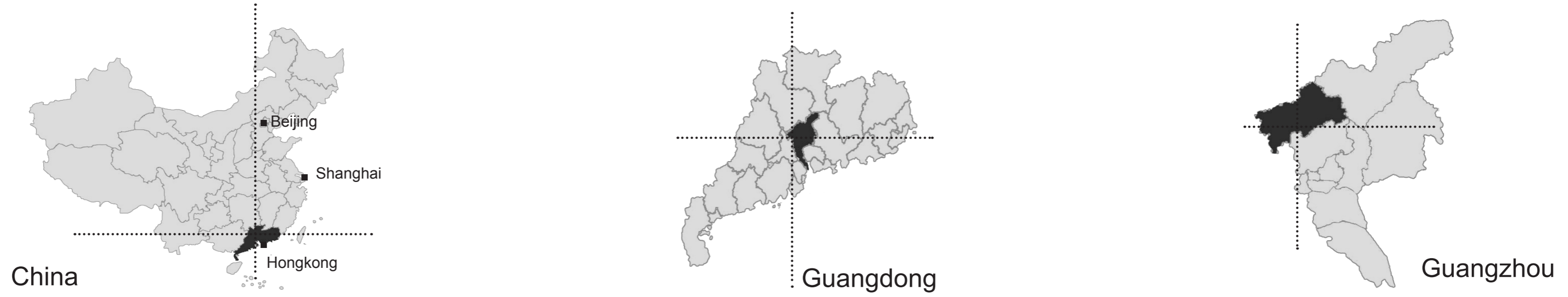
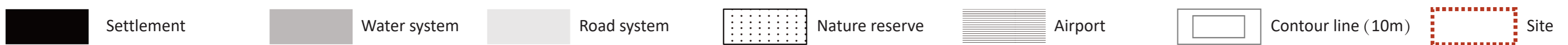

01 Terrain Analysis

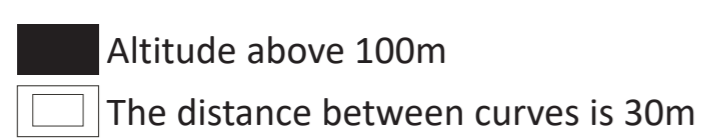
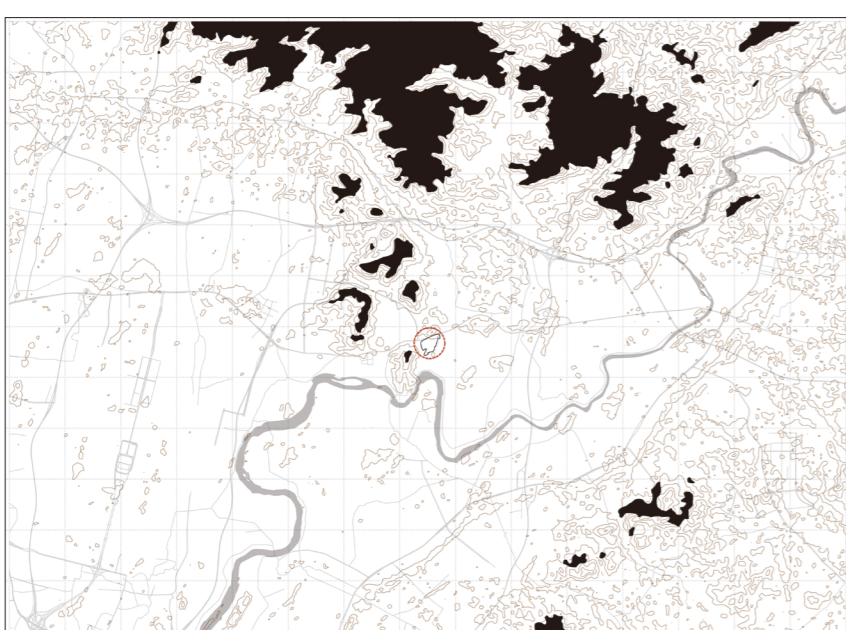

02 Natural Resources

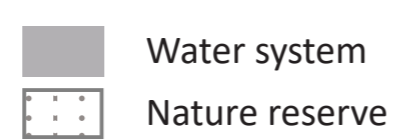

03 Transportation Network

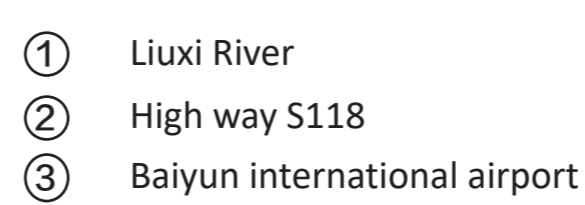
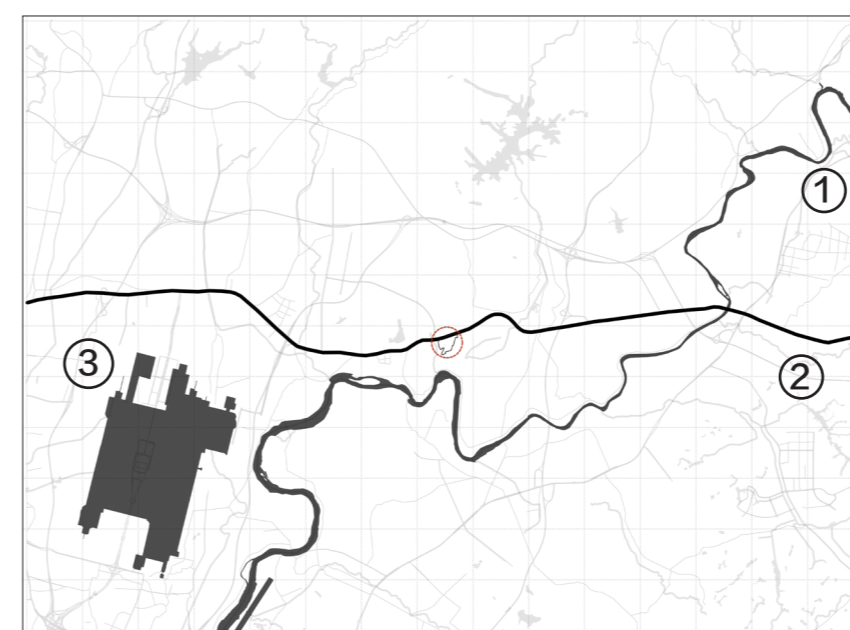

04 Settlement

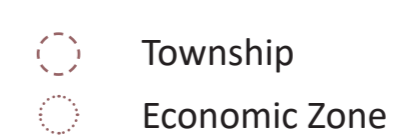

Gangtou Village has a unique geographical environment, which is very suitable for people to live in. This is why the ancestors of Gangtou Village chose this land. But now we enter the village, we find that the current situation of the village is not the same as we can imagine.

Board II Situation of Gangtou Village



Urban fabric



Open space



Road system

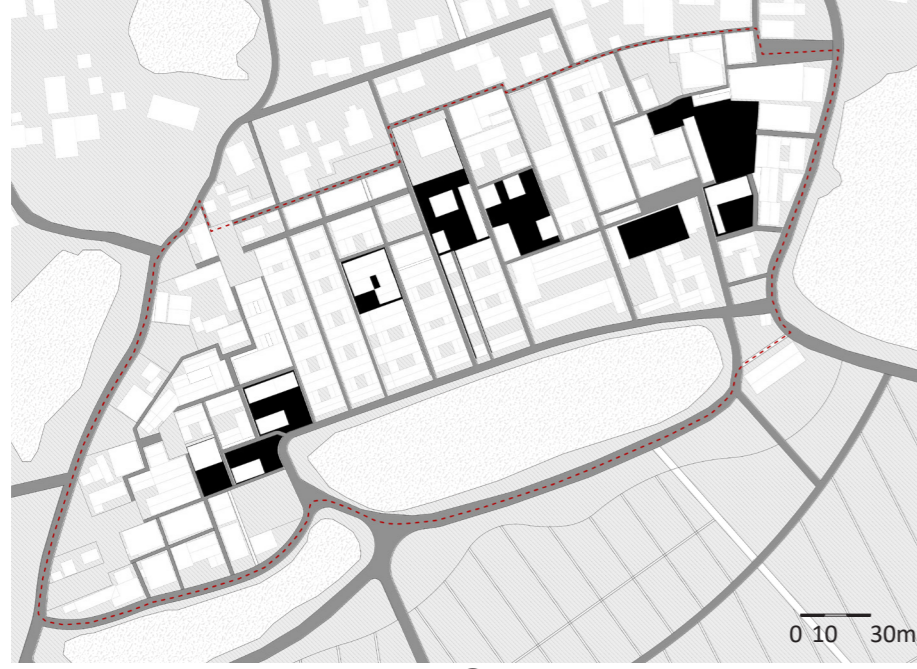

Abandoned Open spaces

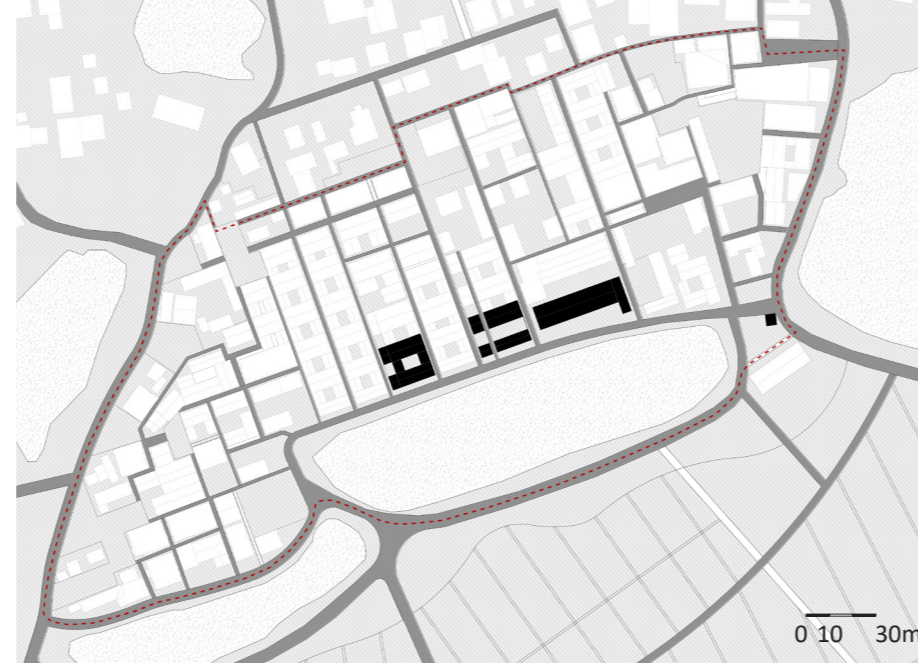

Historical recommended buildings



Abandoned buildings

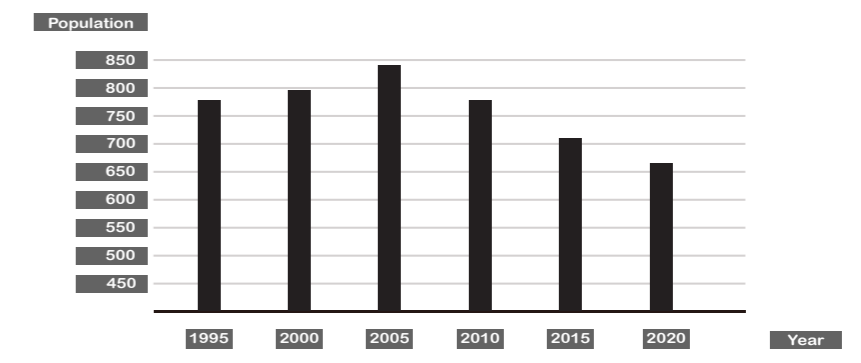

Changes in the total number of people in Gangtou Ancient Village

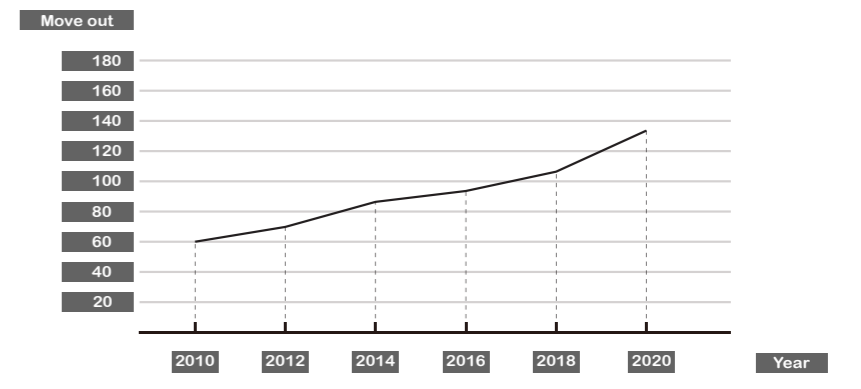

Change of the number of people moving out in Gangtou Ancient Village

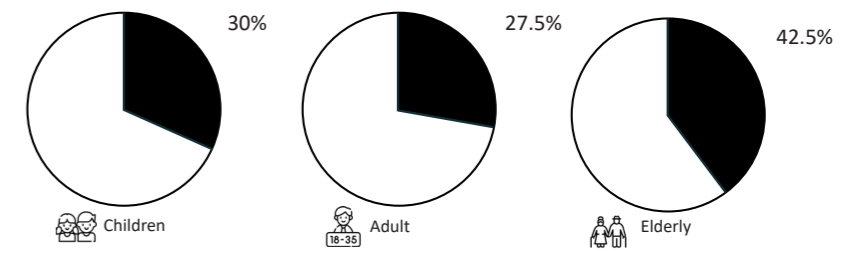

Proportion of different age groups

General Plan Analysis of Gangtou Village

Demographic analysis

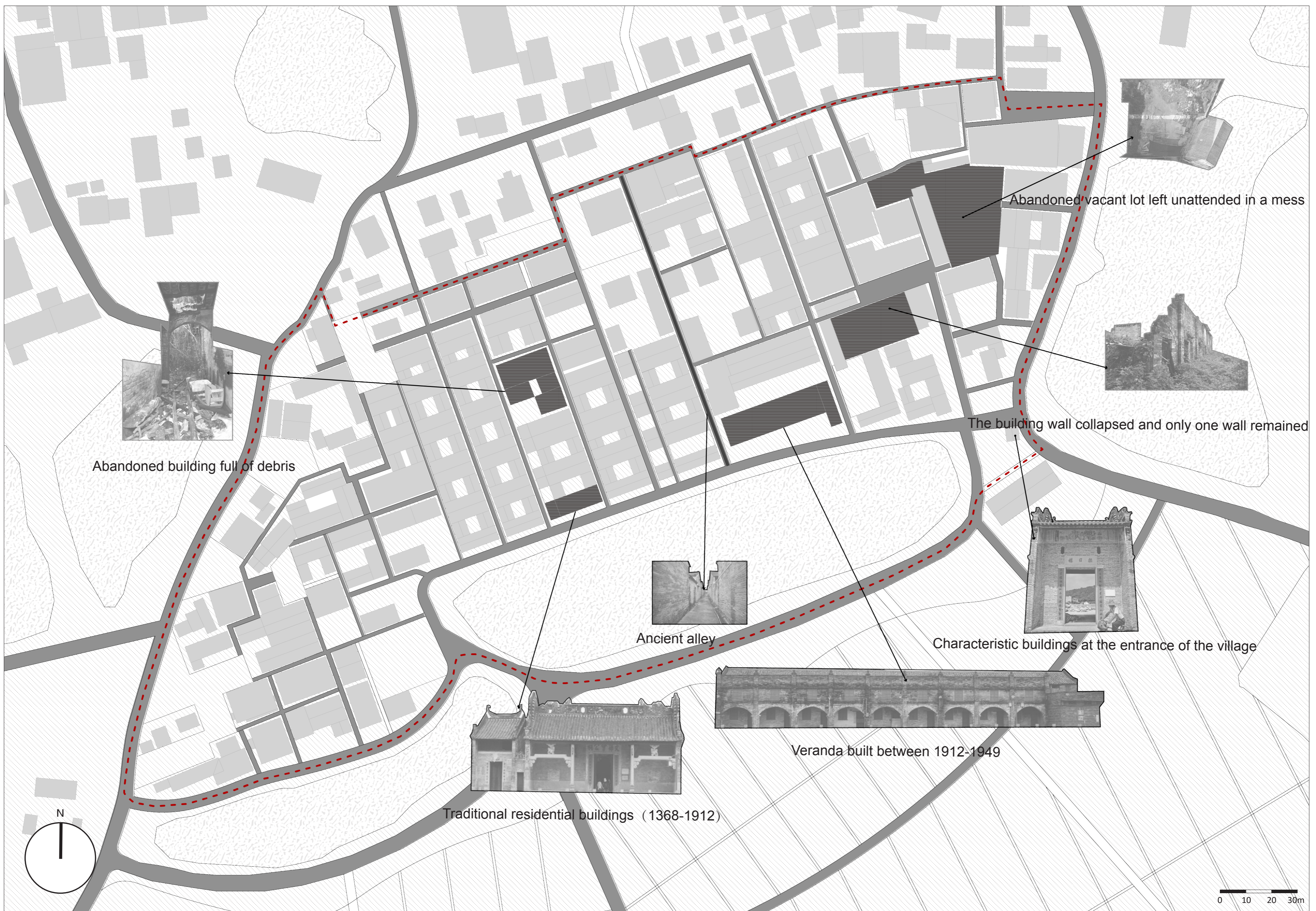

A heterogeneous situation

Agriculture and other low value-added industries



Left-behind elderly and children



Abandoned buildings and open spaces

Main issues



POLITECNICO MILANO 1863 AUC School A.Y. 2022-2023

Thesis title : Awakening Villages . Project by : Chen Jingxuan
 Supervisor : Luca Maria Francesco Fabris . Co-supervisor : Gerardo Semprebon

Board III The "O.V.O.P." strategy based on the lime modelling industry

Lime model on door frame



Lime model on roof

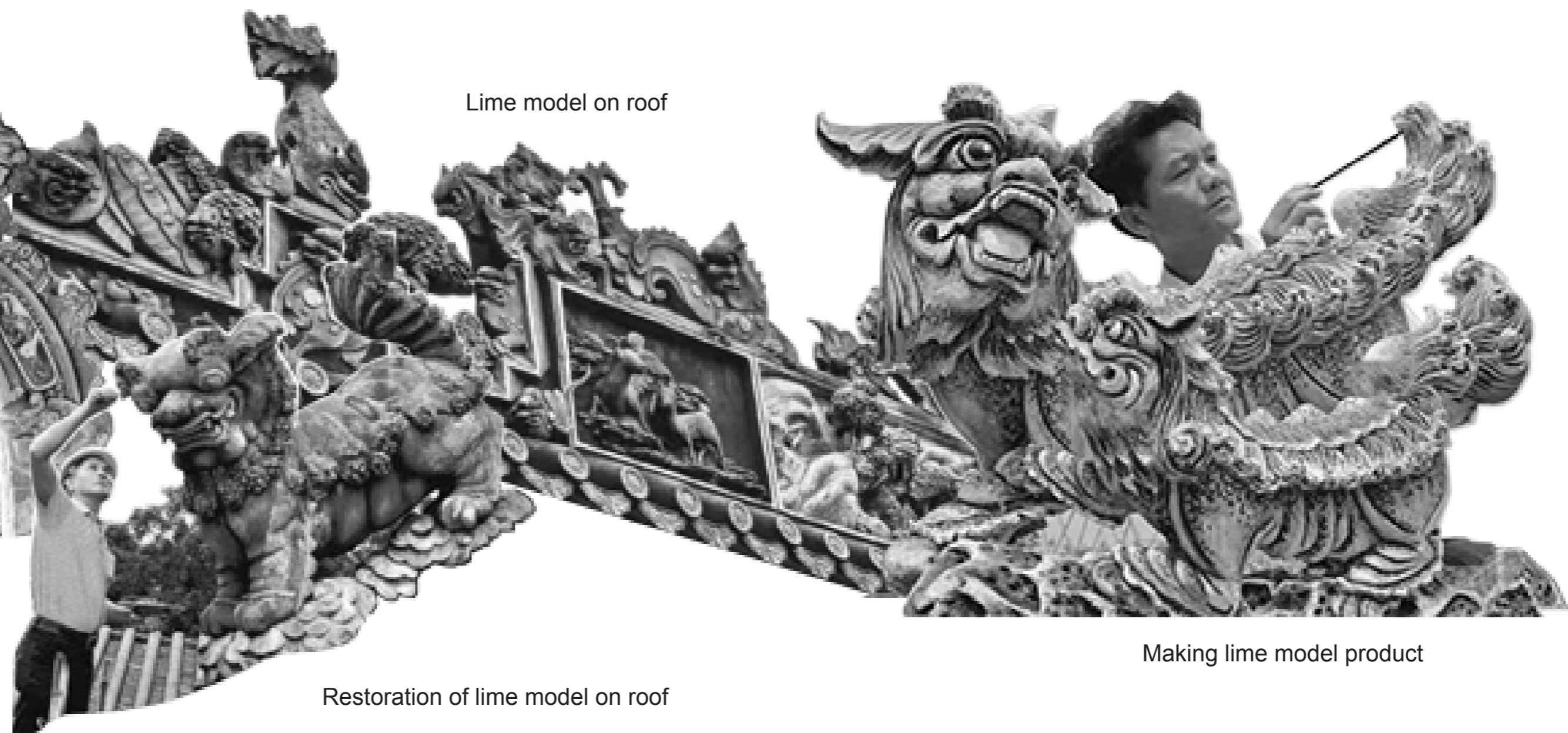

An economic opportunity

Making lime model product

Restoration of lime model on roof

From existing problem to a vision of future development

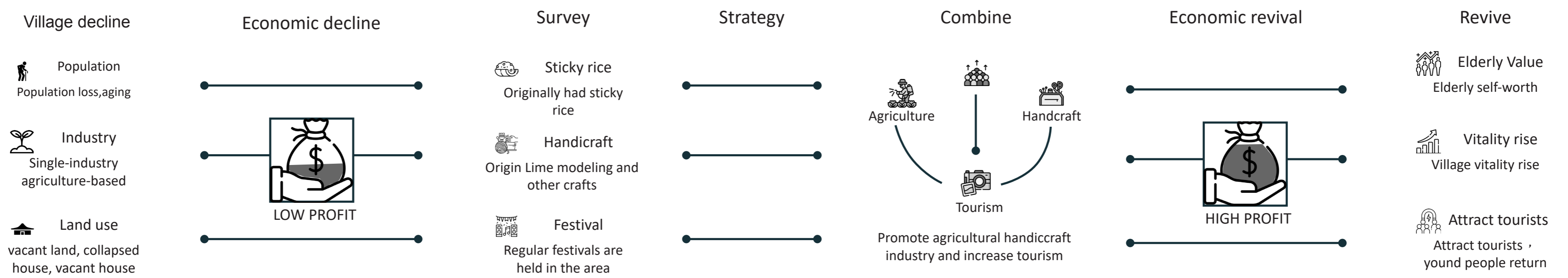

Lime model production process



Four Lime model-related themes

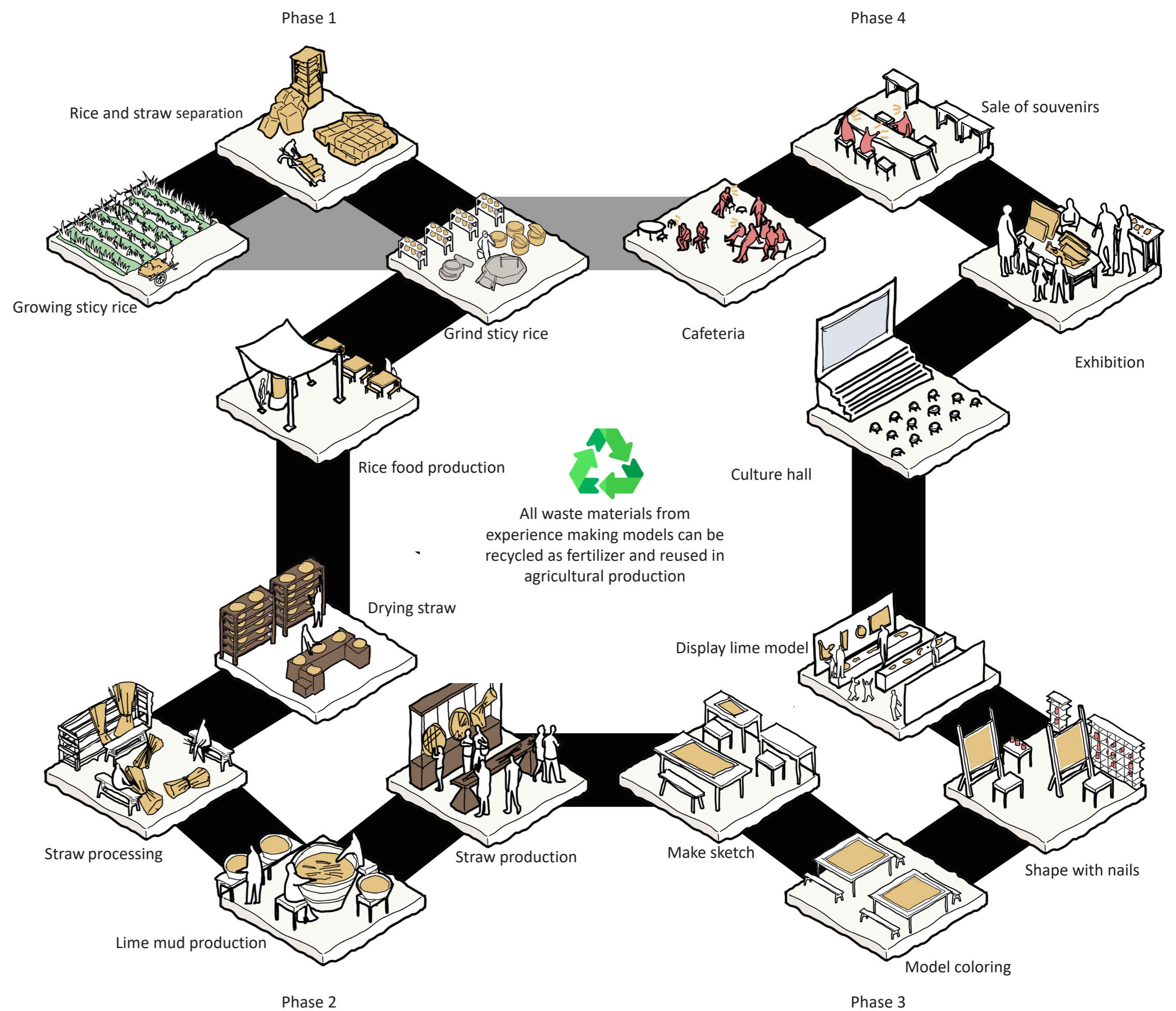

As an intangible cultural heritage with local characteristics, lime modelling can be used as a value to promote the village. The lime model industry will attract foreign tourists to come and study, and will create employment opportunities and will promote the return of the lost population in the village.

Board IV Acupuncture applied in Gangtou Village

Activate the village by renovating several abandoned buildings and open spaces in the village

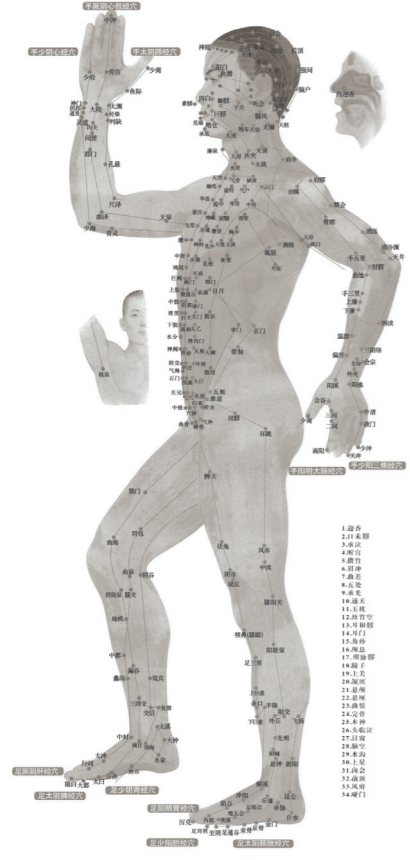

Acupuncture in Traditional Chinese Medicine



There are a lot of abandoned buildings and weedy open spaces in Gangtou Village.

- Step 1 ——— Problems found ——— The loss of population caused some buildings in the village to collapse, and some open spaces were covered with weeds, and the village lost its former vitality.
- Step 2 ——— Choose acupuncture points ——— Select uninhabited abandoned buildings and open spaces in villages
- Step 3 ——— Treatment Insert functions ——— The previous site was selected as a carrier to incorporate the function of lime modelling industry.
- Step 4 ——— Unblocked the "Meridians" ——— Connect all the acupoints to form a tourism loop, which not only attracts tourists but also creates jobs and promotes population return.

Renovation spaces

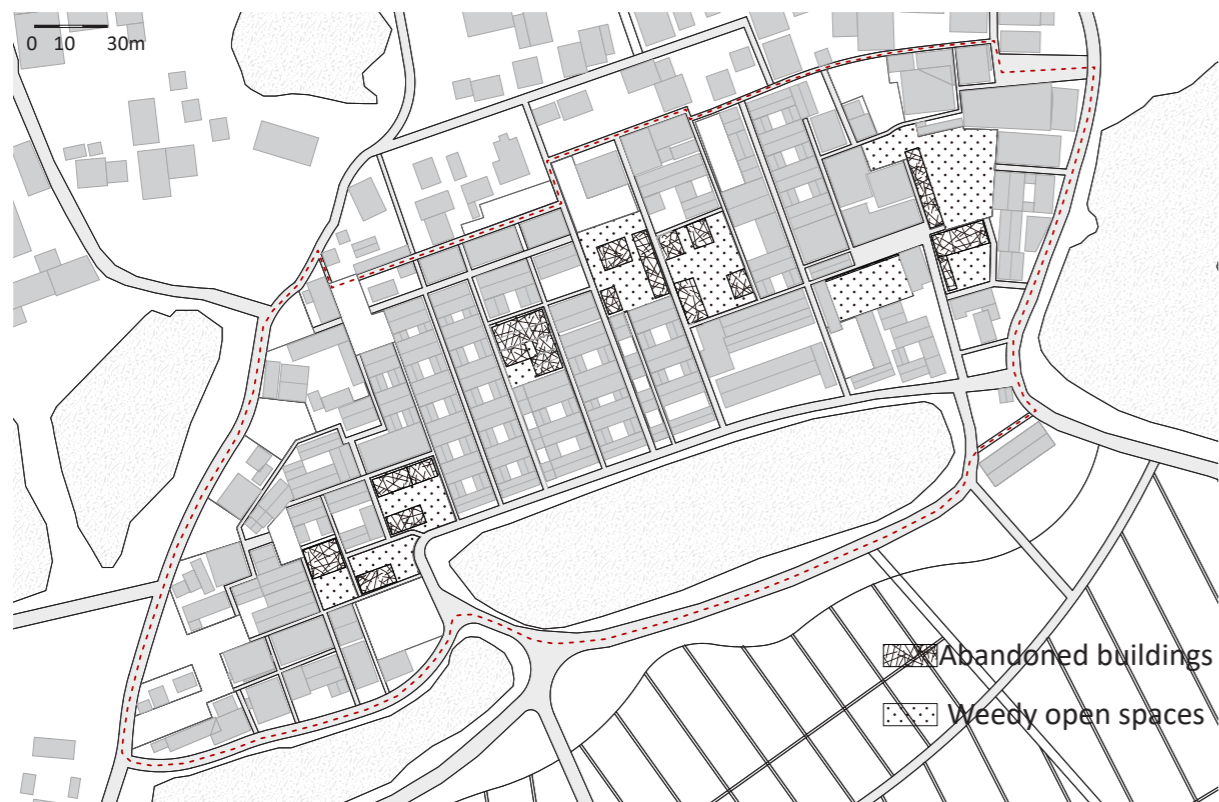

There are a lot of abandoned buildings and weedy open space in Gangtou Village

Industry convergence



Incorporate the lime modelling industry into the previous site

Recommended route

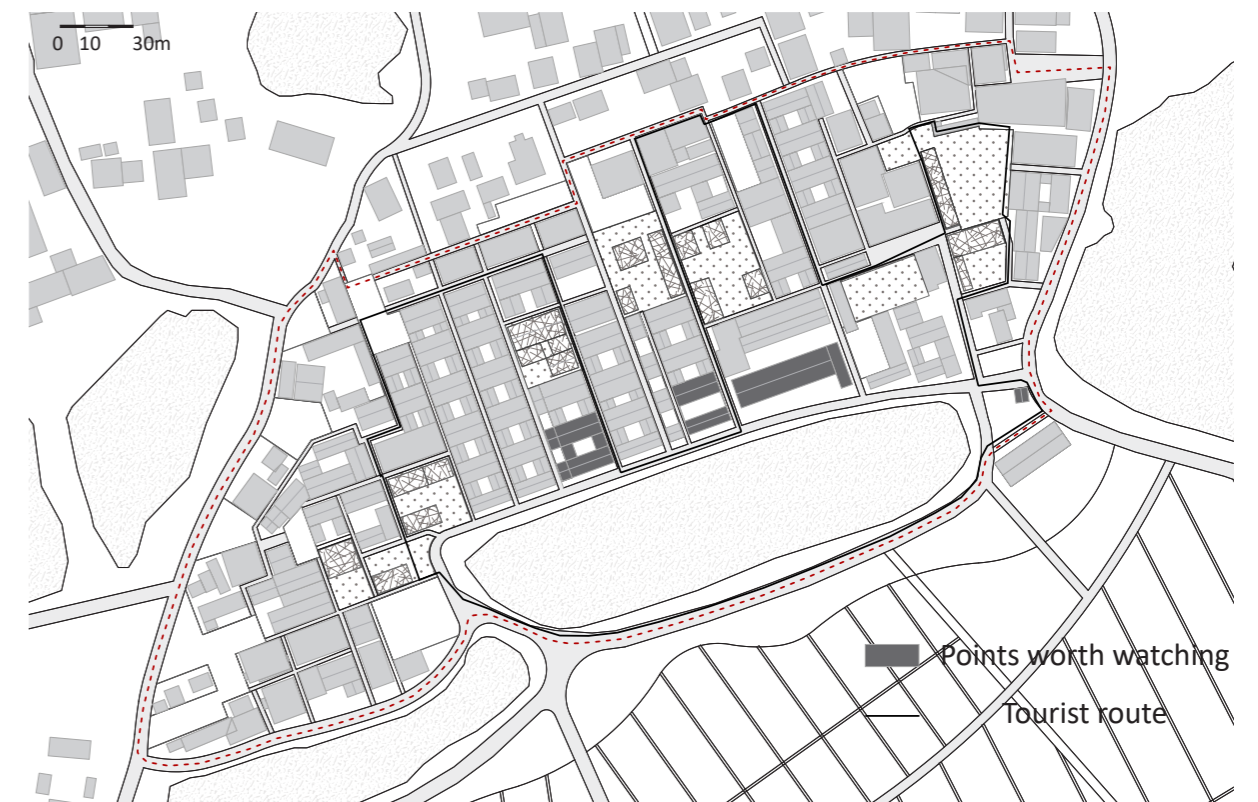

Combining industries, ancient buildings and ancient alleys, a recommended route is formed.

Masterplan analysis of Gangtou village

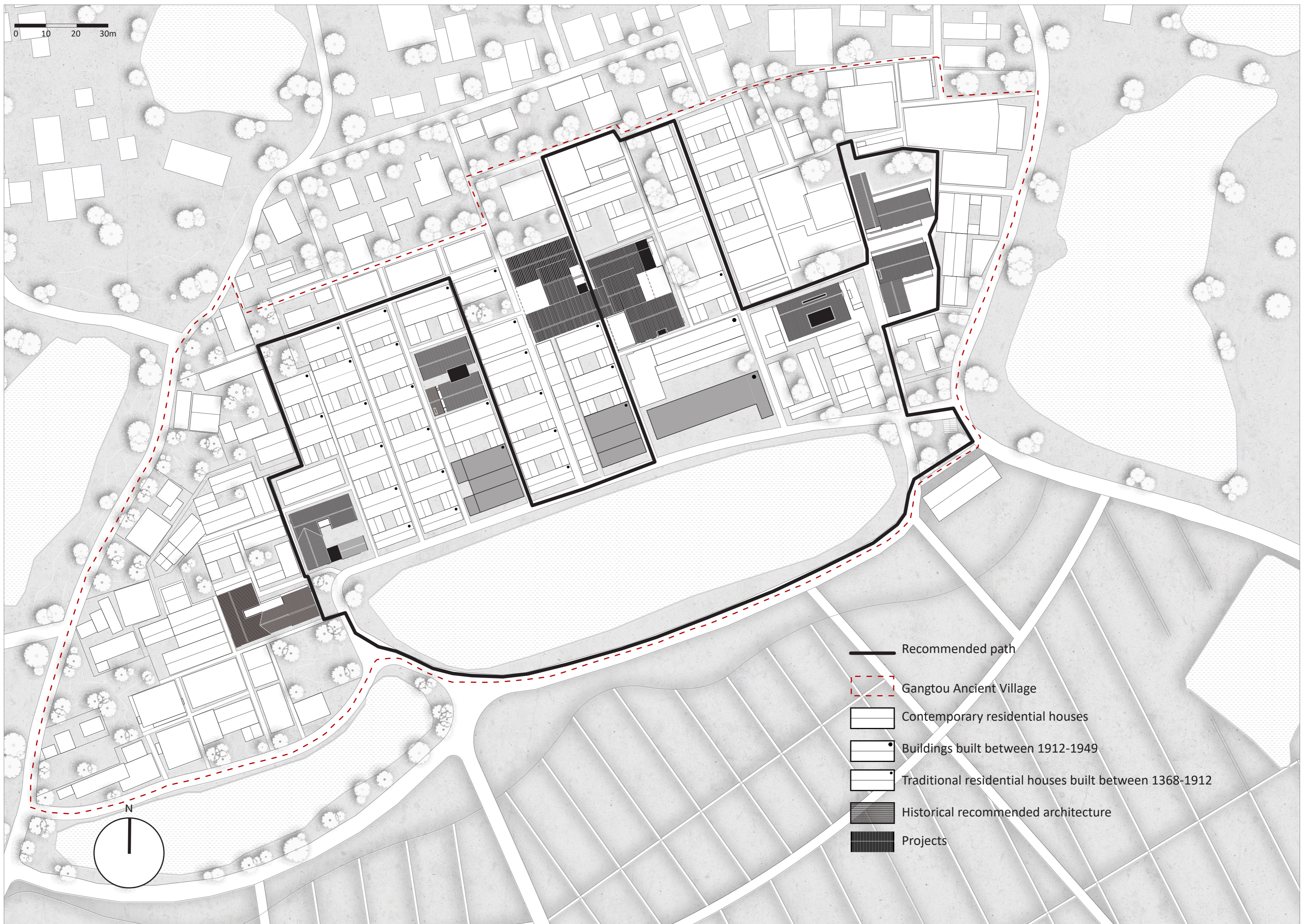

Through acupuncture and moxibustion therapy, the abandoned buildings and open spaces in the village will fully utilize. The loop formed by these small renovations will become an important part of the tourism development. This is to achieve the greatest impact on the village through the transformation of key buildings.

Board V Focus project area

Geographic center of the village

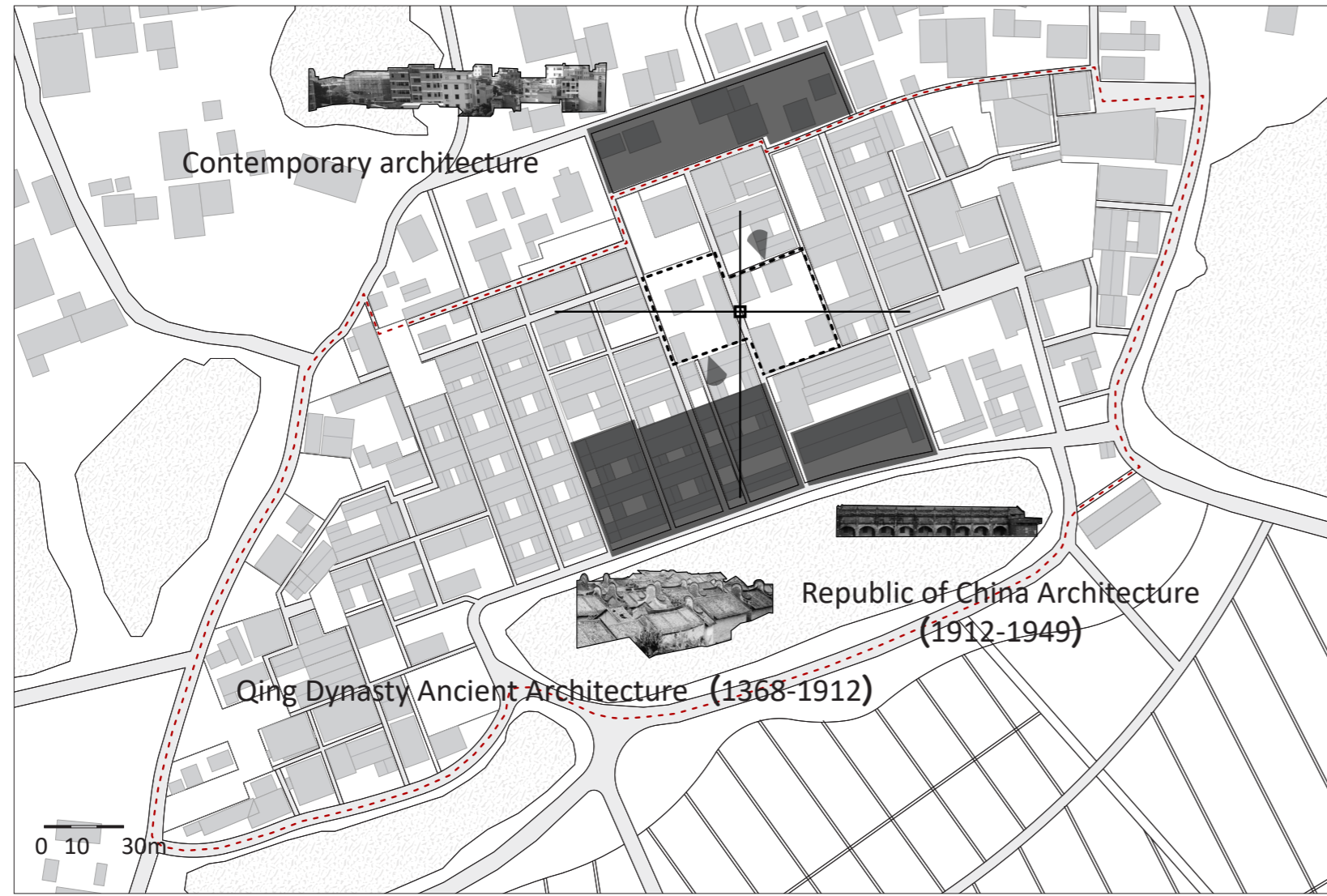

Industrial center of Lime modelling

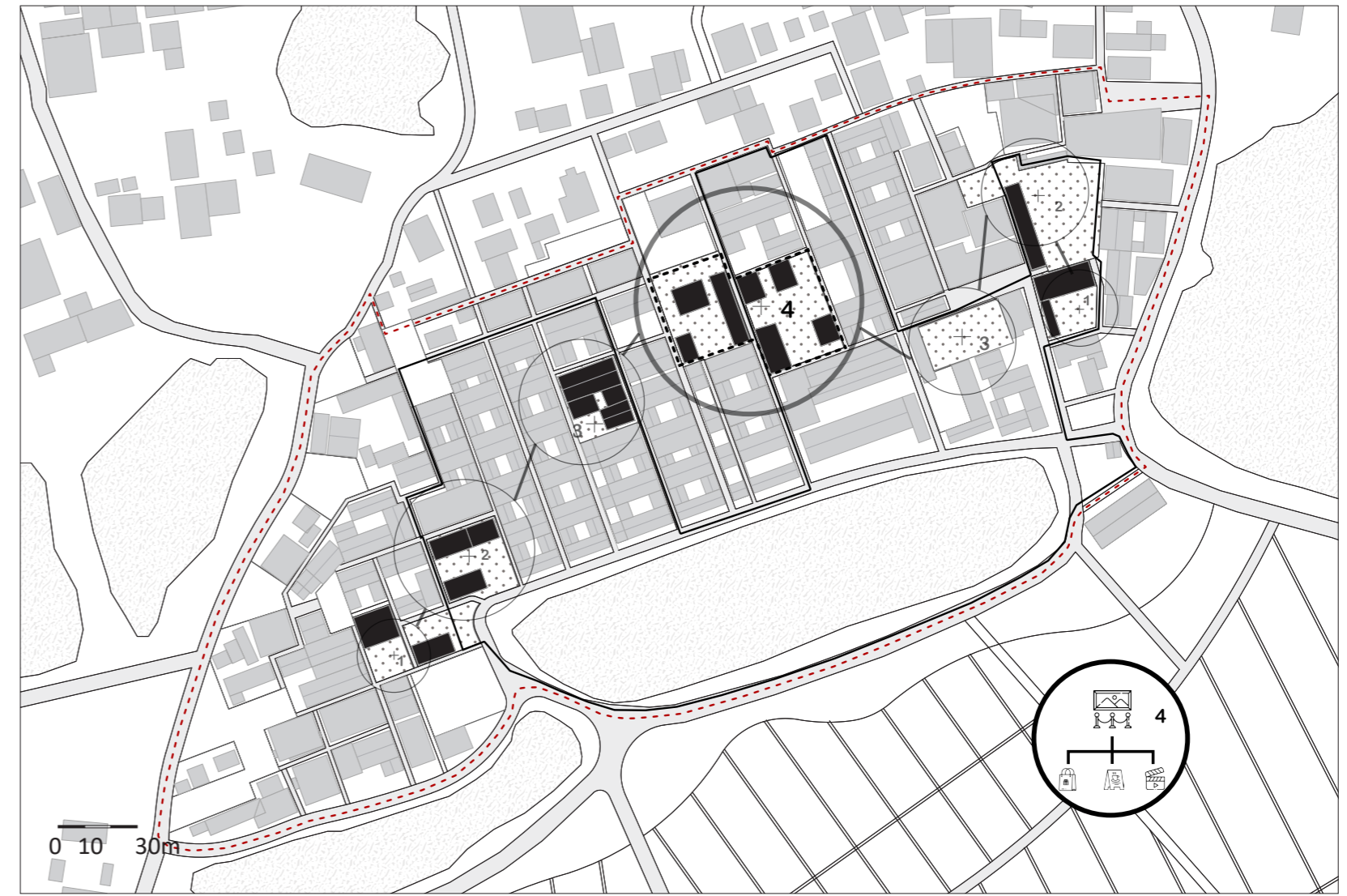

Current situation



Building condition



Part of the roof collapsed, with tiles strewn across the ground



Part of the wall collapsed and the load-bearing structure of the building was damaged



The building is abandoned, no one tidying up, and the interior of the building is full of debris

Green area condition



Plants have flooded the building, affecting building lighting.



Plants grew into the interior of buildings, seriously affecting the use of the buildings



Plants left unattended, growing in entrances and exits of abandoned buildings.

Materials

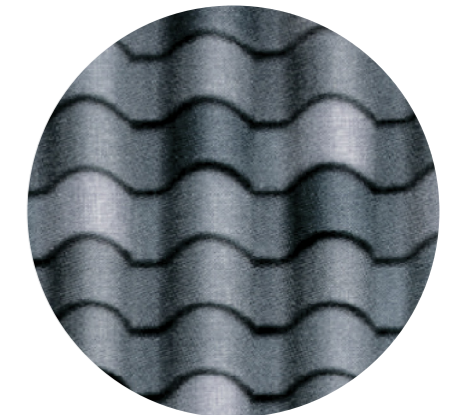

Gray roof tiles



Local characteristic gray brick wall



Wooden materials in the interior

Building condition

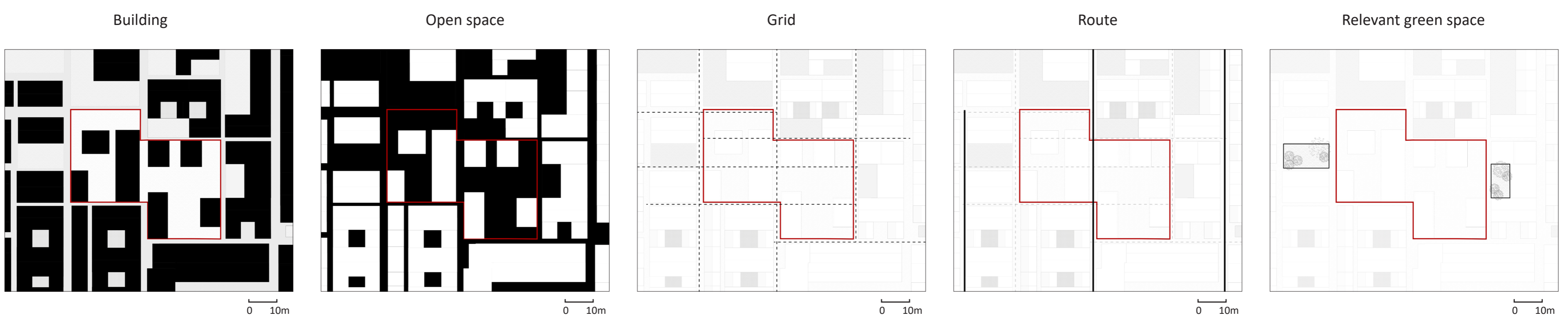

Site schematic sections

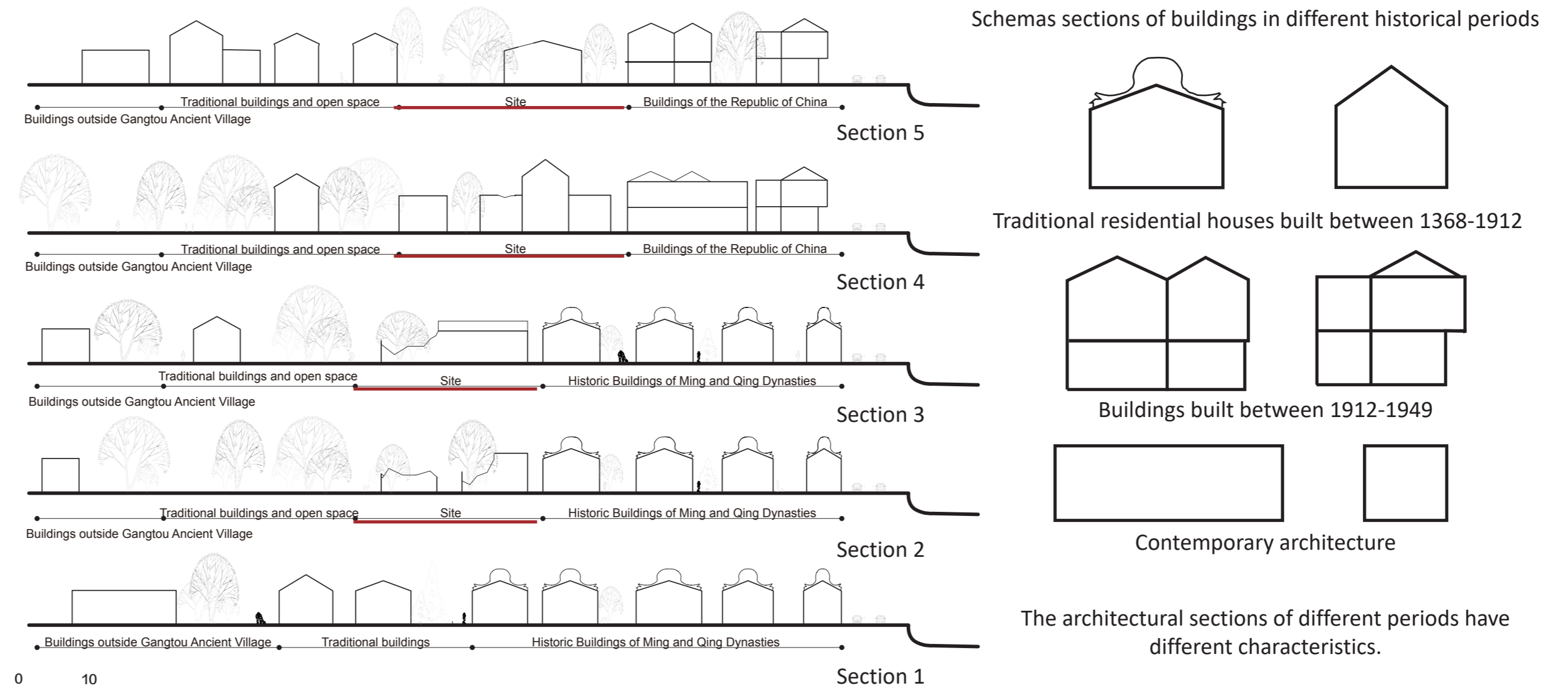

Board VI Reinterpreting the historic built fabric

Volume generation logic

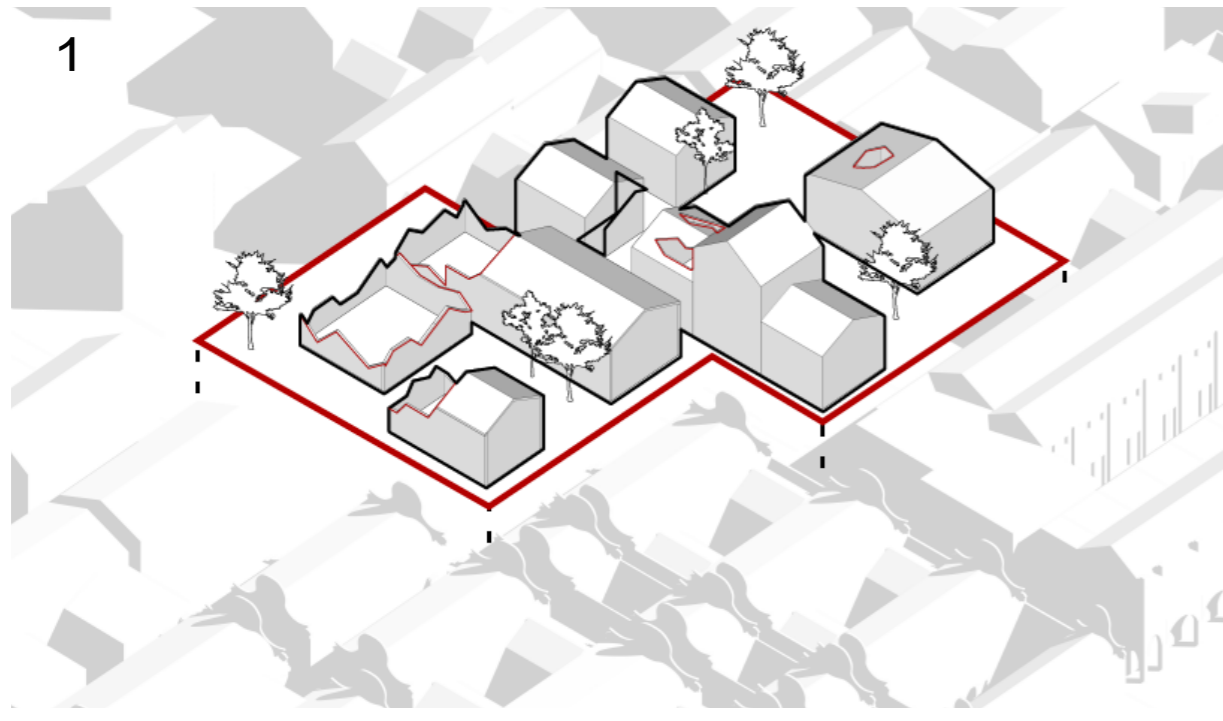

Abandoned buildings and landscapes on site

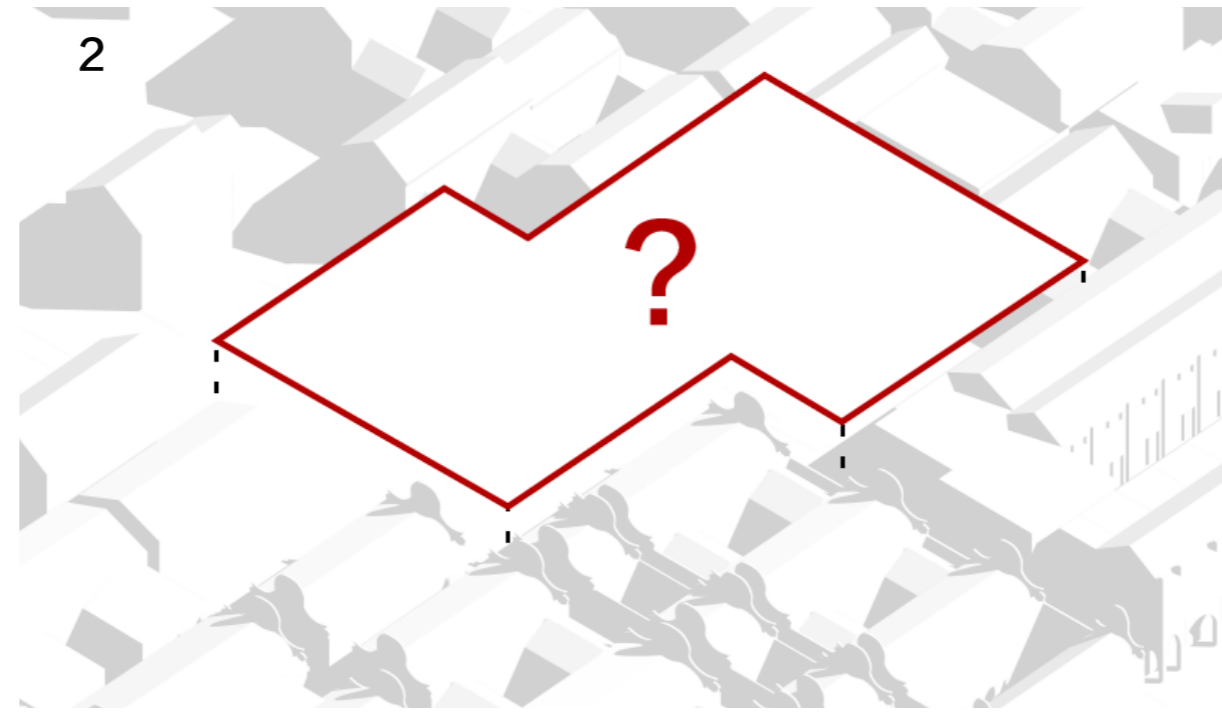

Site reconstruction, New and old?

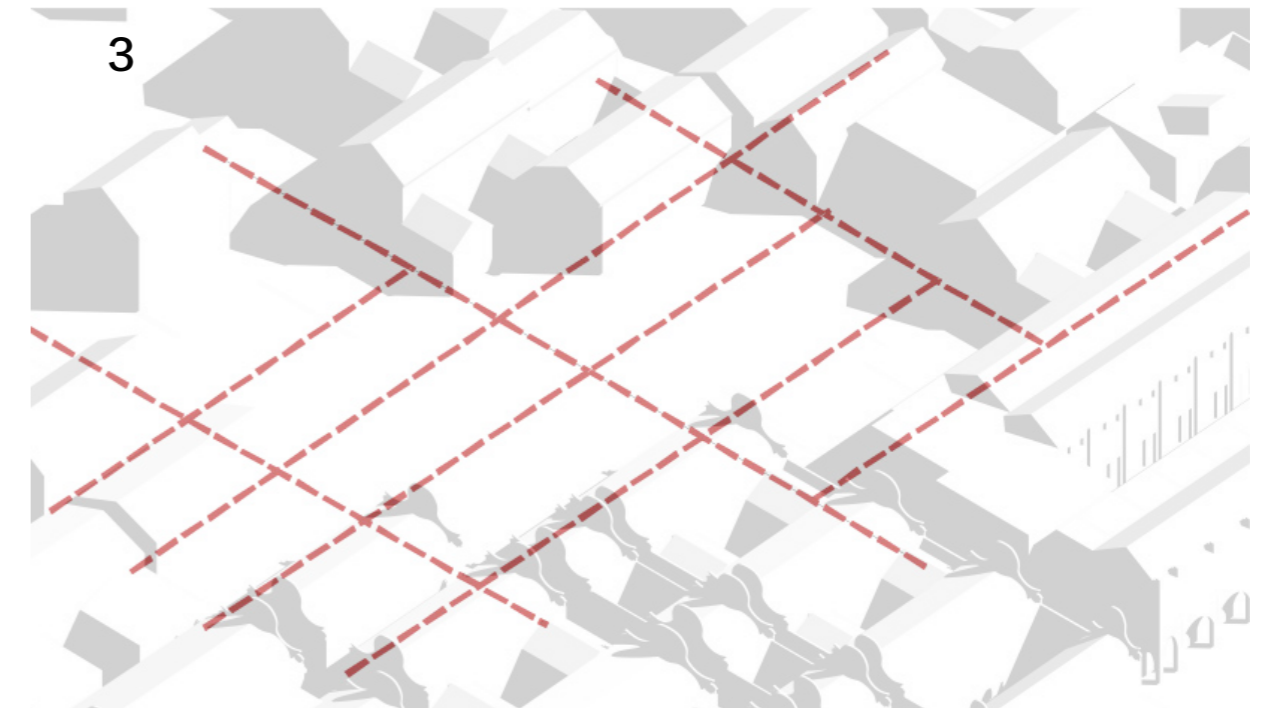

Ancient alley as a grid

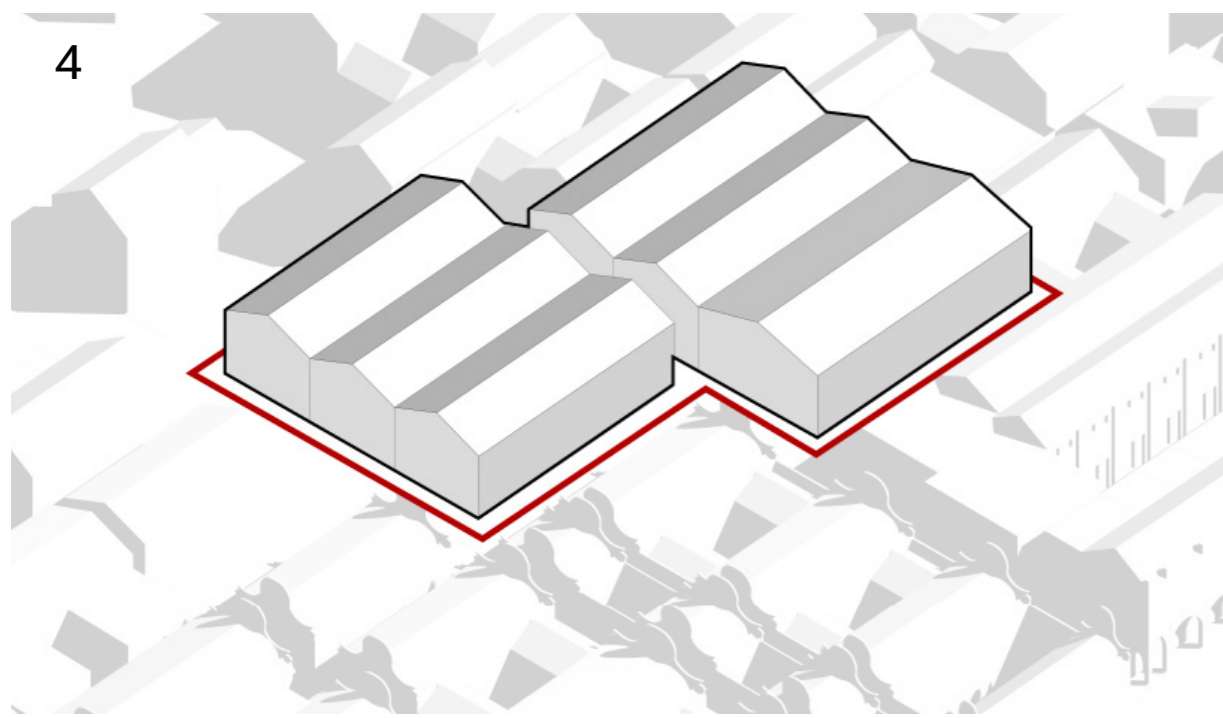

Original form

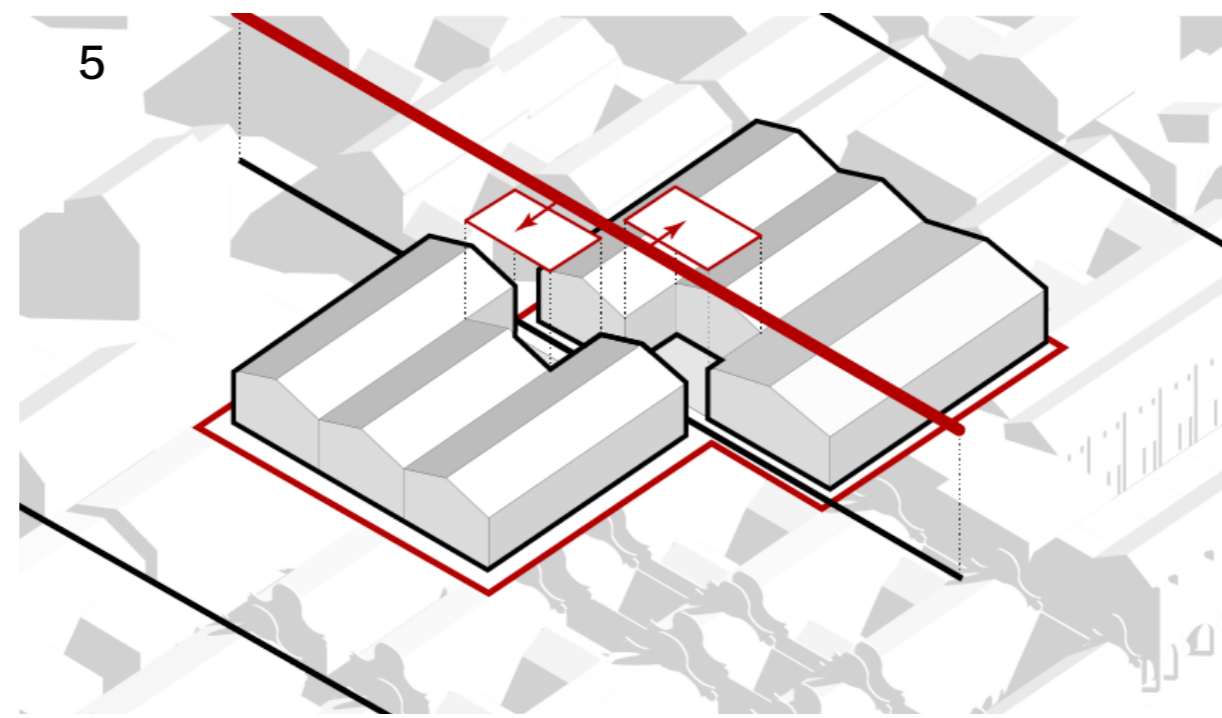

The main entrance is placed on the main route

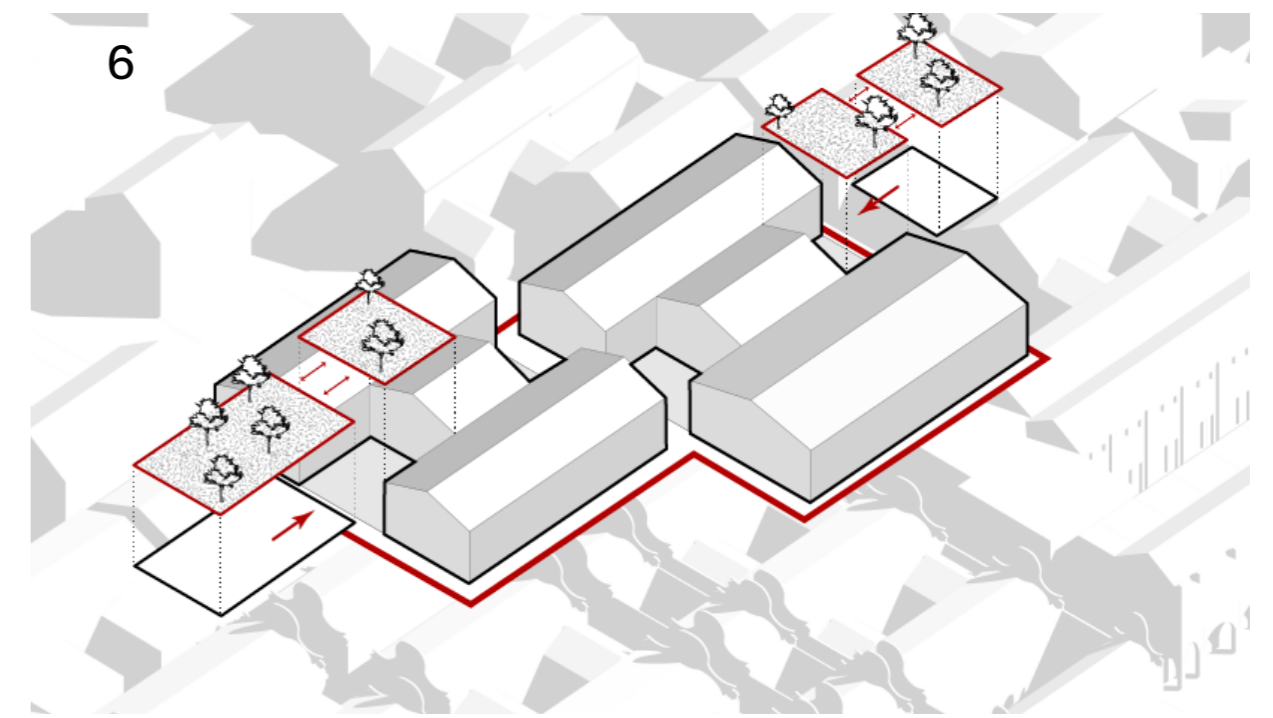

Echoing the surrounding landscape of the site

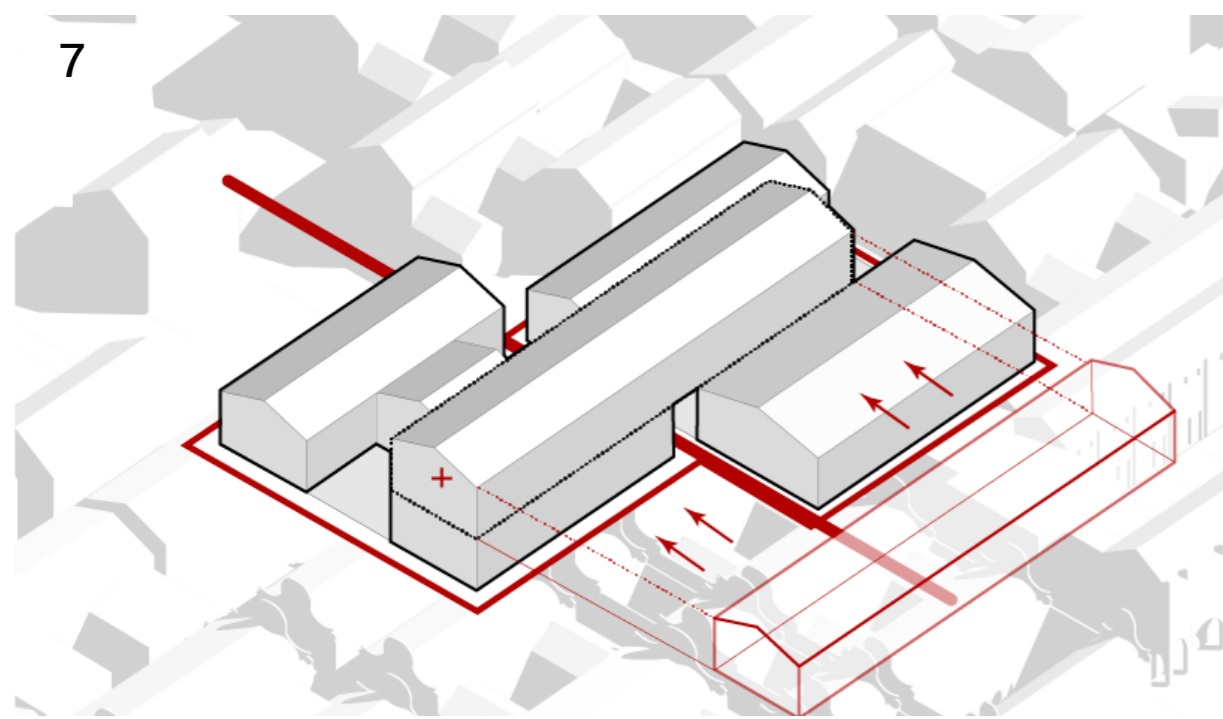

Use a volume to connect the two parts of the site and keep the sight line of the main route unobstructed

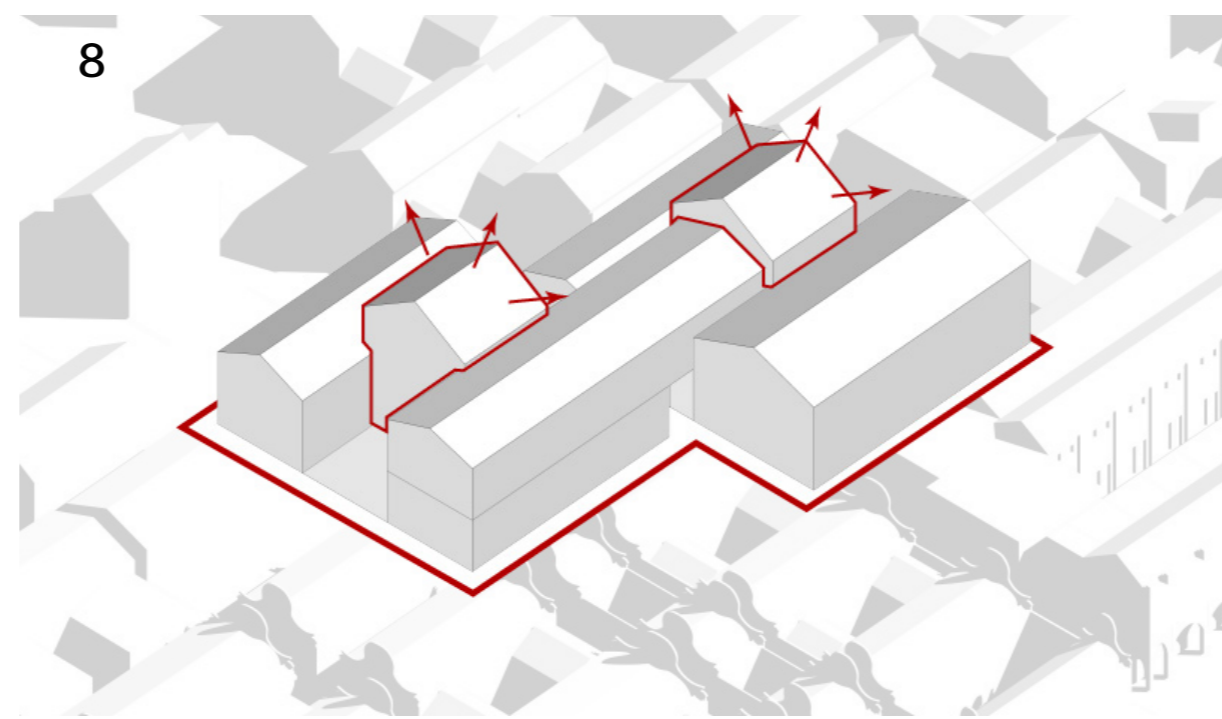

Expand connection space

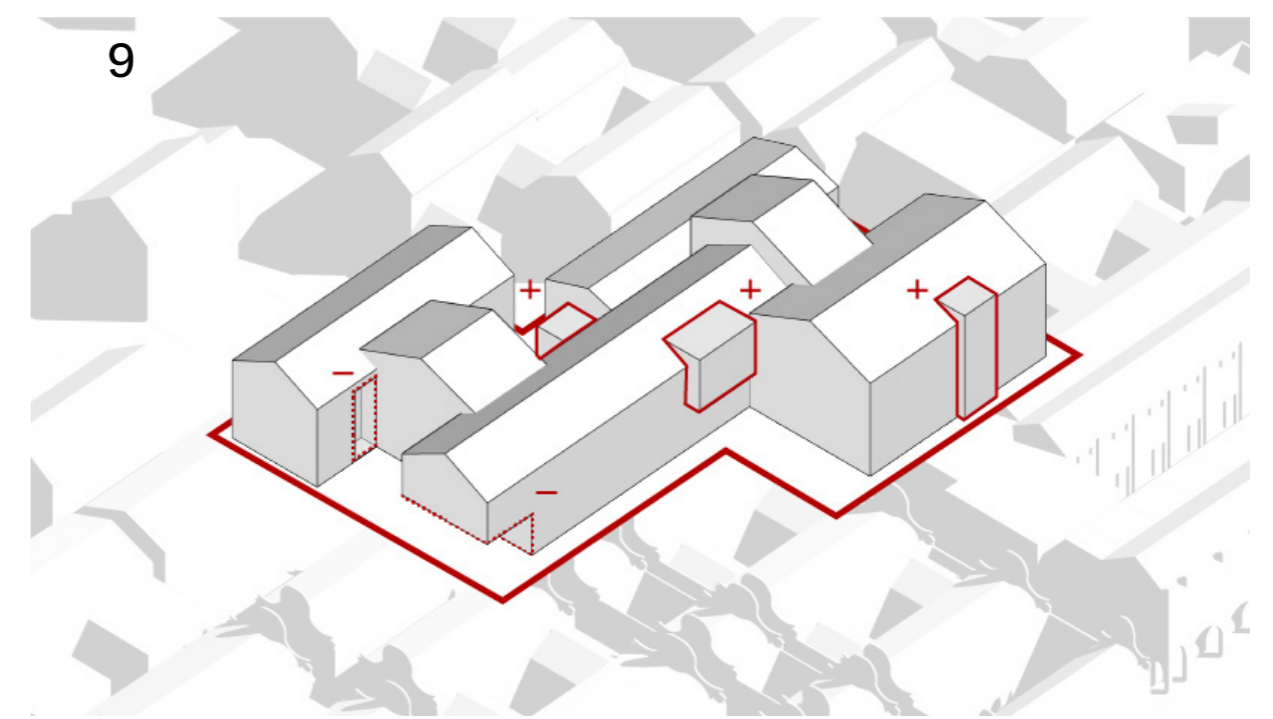

Adding square blocks to increase spatial diversity

Due to the low quality of buildings and greenery in the site, the design intends to build a new building on the site. The overall architectural shape is formed according to the original village texture, echoing the original village texture.

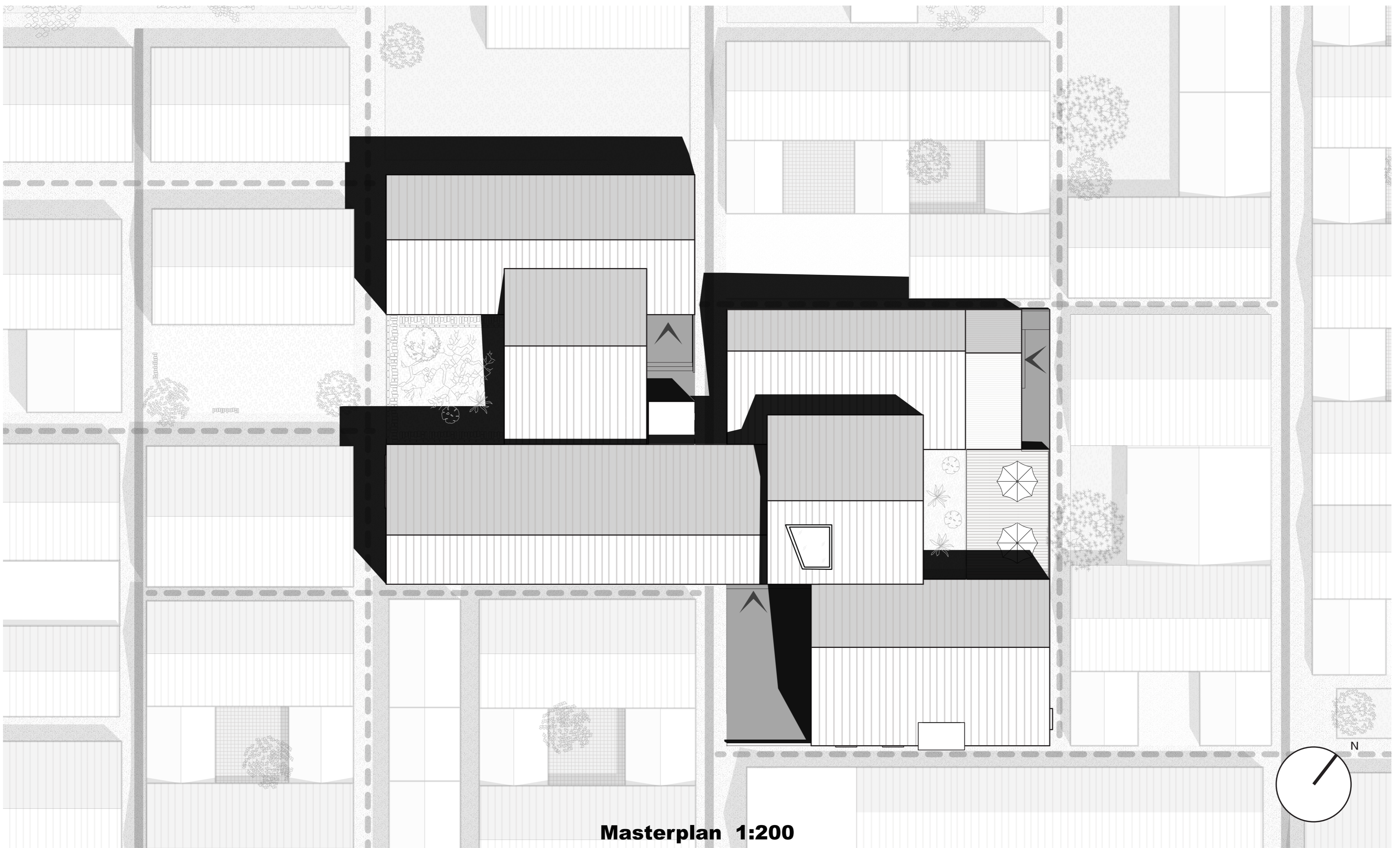

Masterplan 1:200

Board VII Inheriting the site culture

Ground floor 1:200

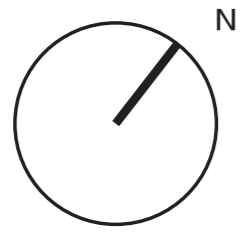

- 1. Entrance plaza
- 2. Tourist Information
- 3. Lime model history exhibition
- 4. Office
- 5. Roof lime model exhibition
- 6. Lime model tools exhibition
- 7. Lime model raw material
- 8. Entrance plaza
- 9. Toilet
- 10. Cafe
- 11. Outdoor dining area
- 12. Gift Shop
- 13. Cultural Salon Area

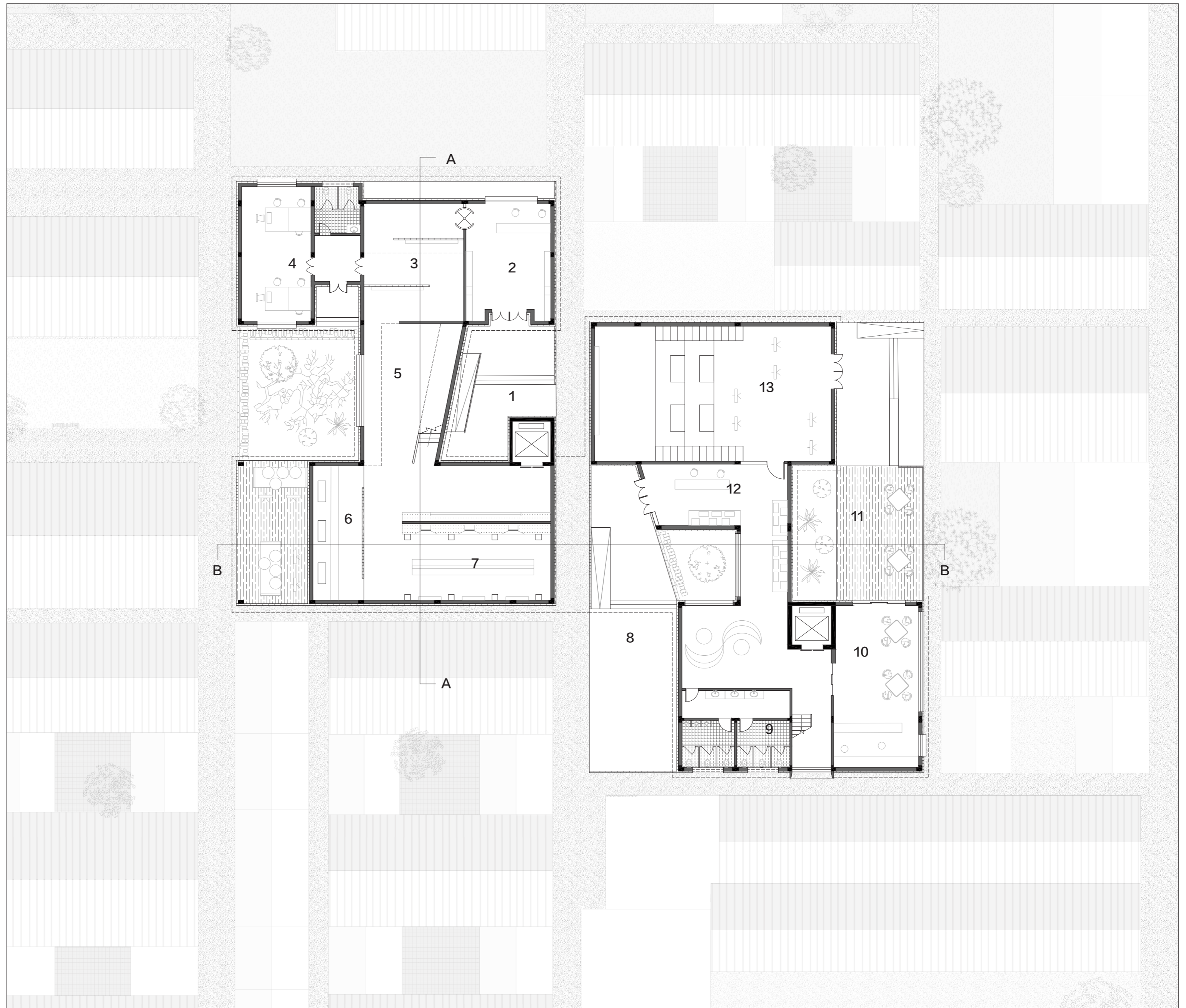

First floor 1:200

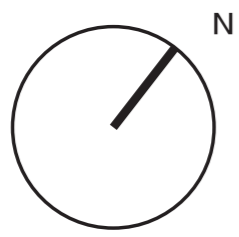

- 1. Leisure
- 2. Lime model history exhibition
- 3. Roof lime model exhibition
- 4. Door lime model exhibition
- 5. Viewing platform for traditional buildings
- 6. Viewing platform for contemporary buildings
- 7. Toilet
- 8. Leisure

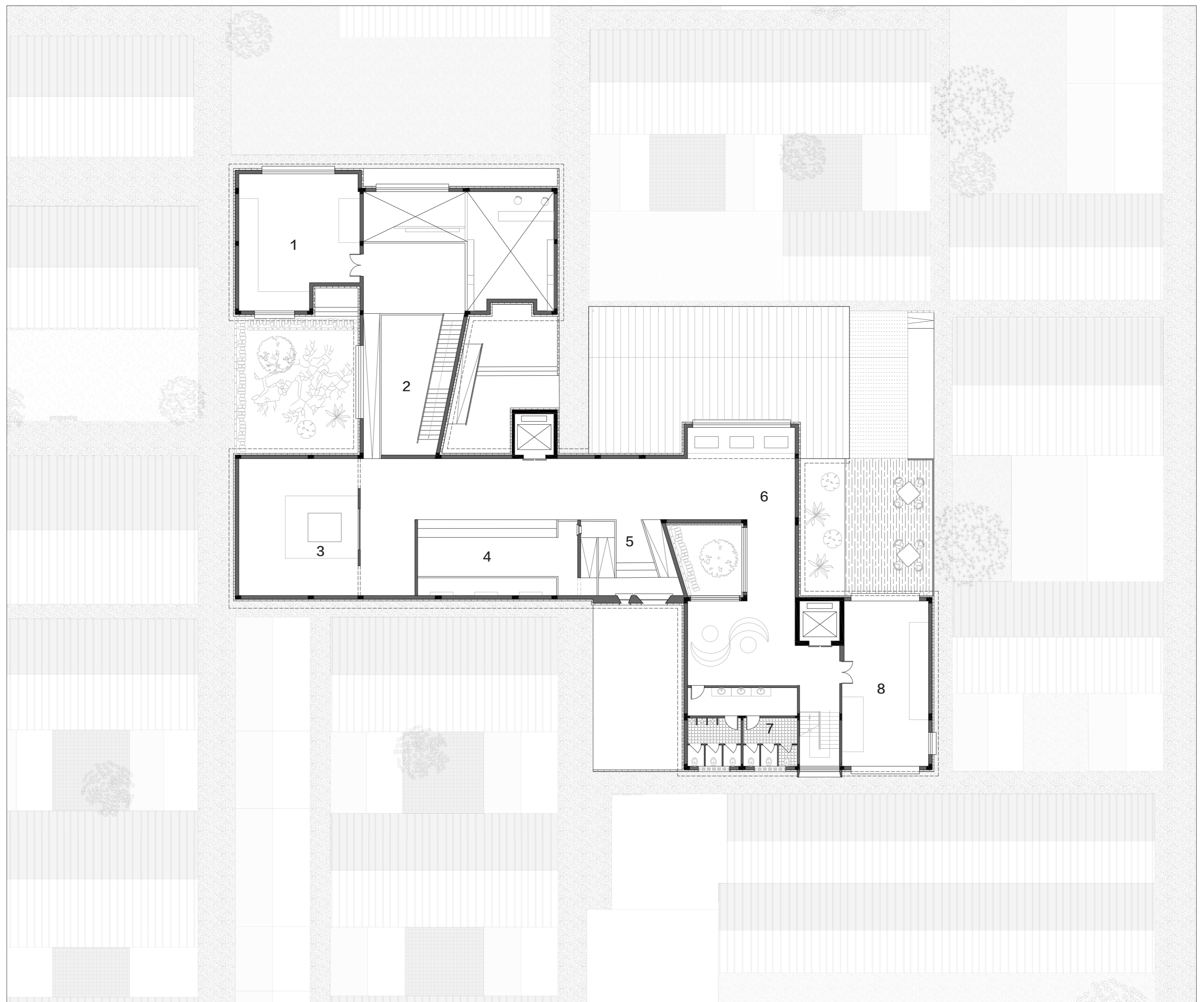

By visiting the entire building, people can systematically understand the lime modelling industry. Popularizing the lime modelling industry is conducive to the continuation of traditional culture.

Board VIII Working on the Spatial relationships

Single space concept

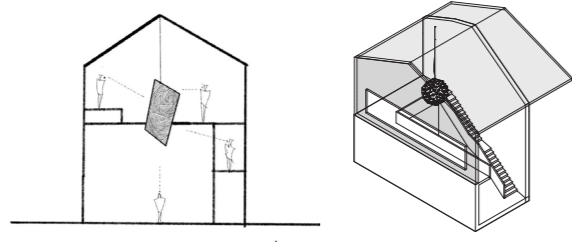
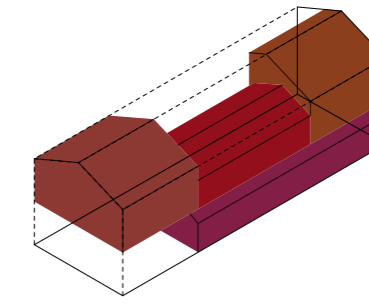
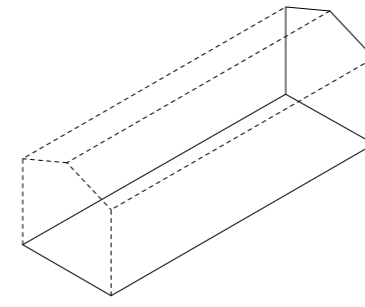
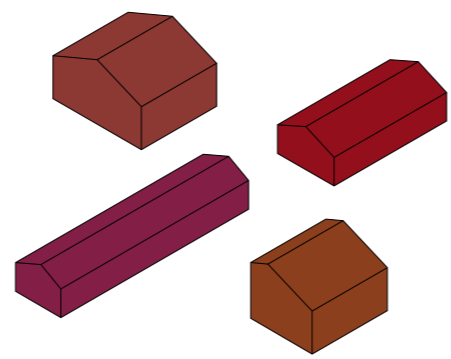
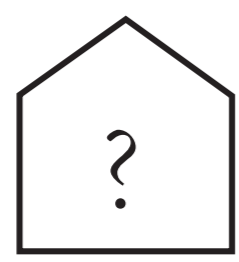

Display Area I – Multiple angle views

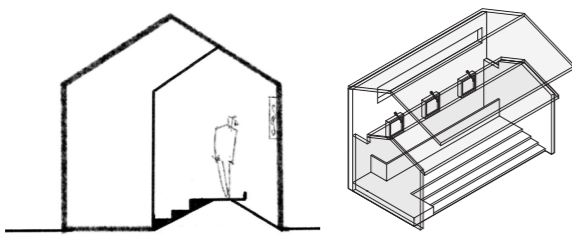

Display Area III – Focus views

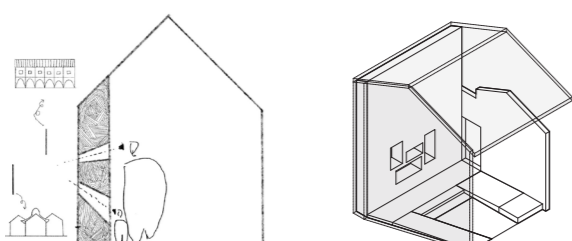

Viewing platform I – Historic buildings

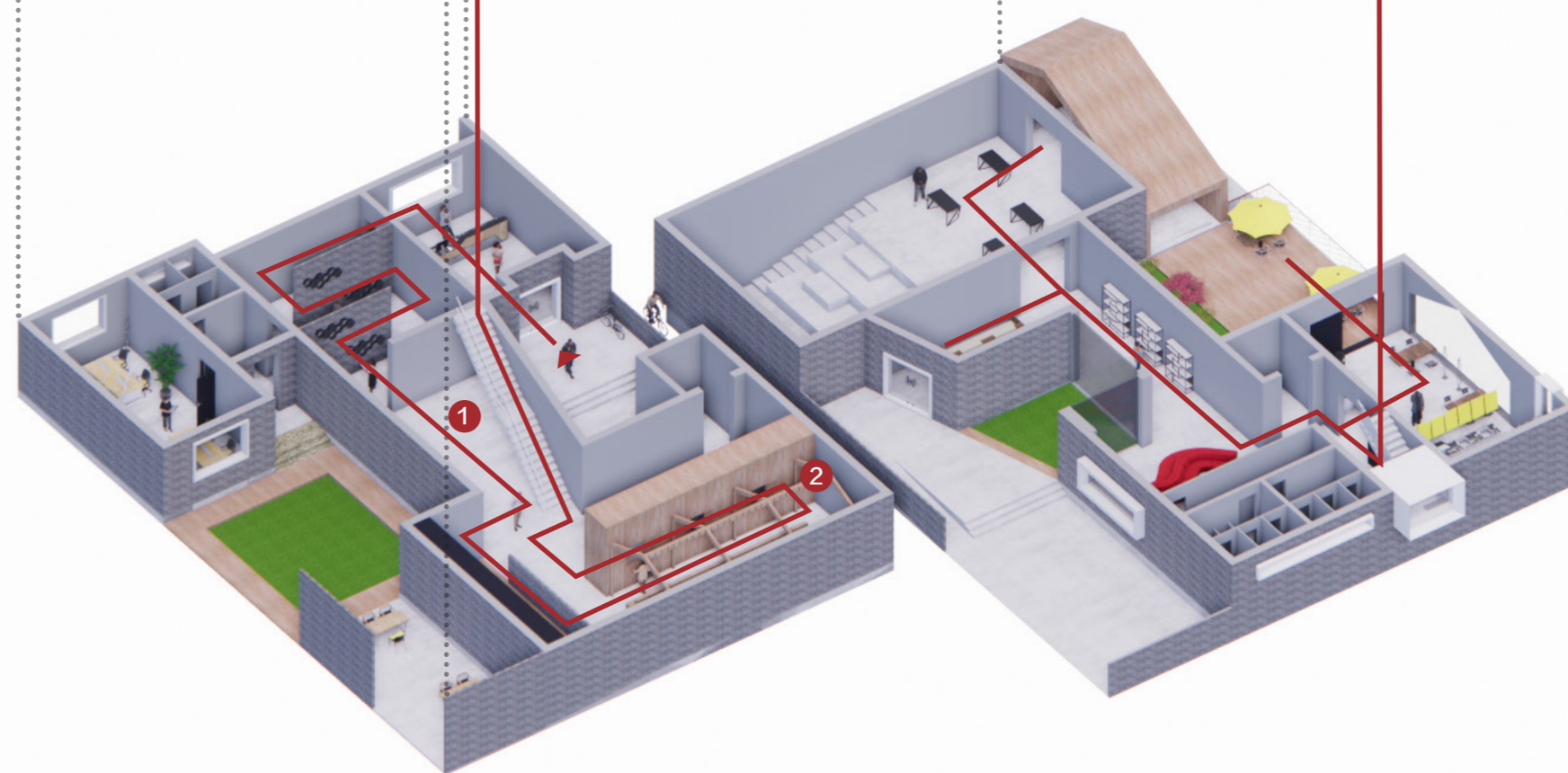
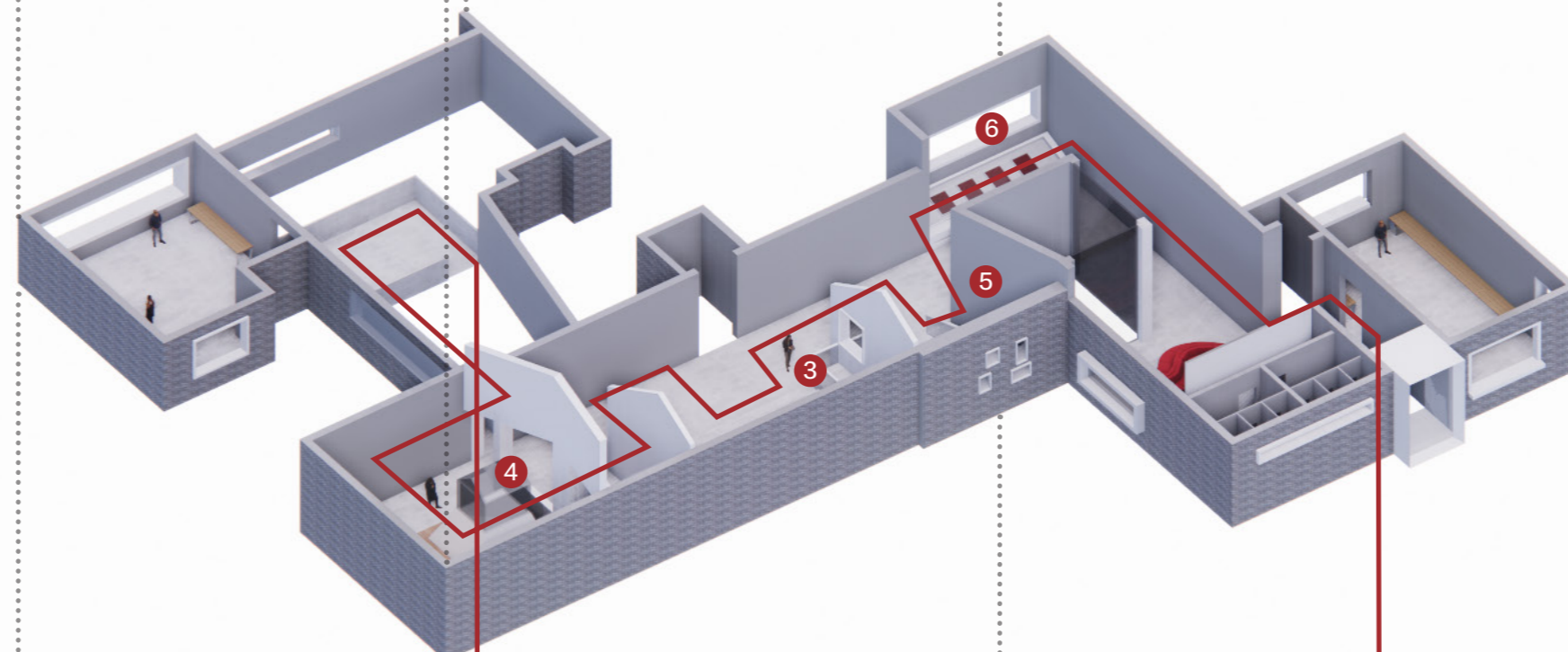
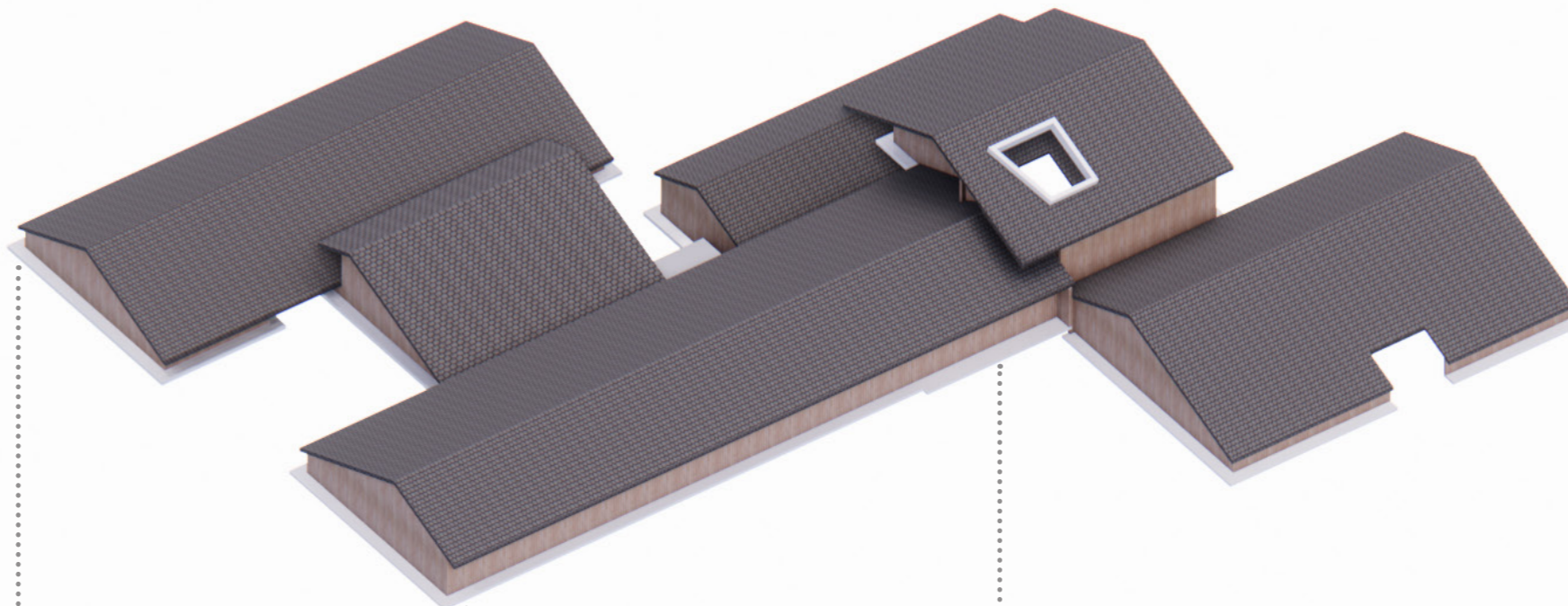

— Exhibition route

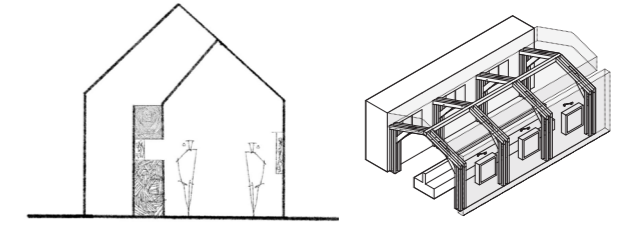

Display Area II – Closer and Wider views

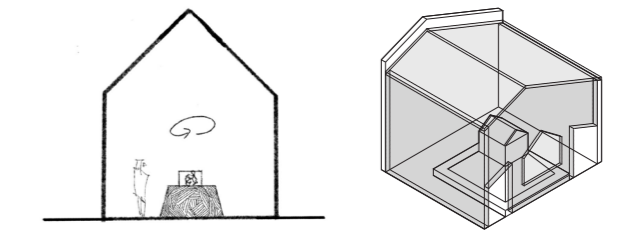

Display Area IV – 360° views

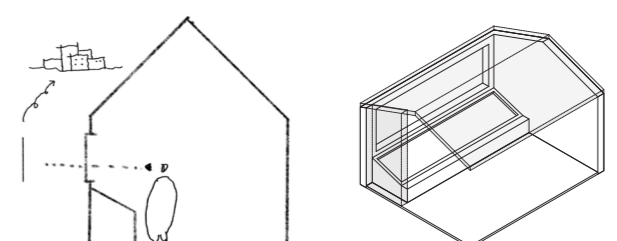

Viewing platform II – Contemporary architectures

Space combination concept

Republic of China era architecture

Architectural prototype

Subtraction

Architectural prototype

Subtraction

Final shape

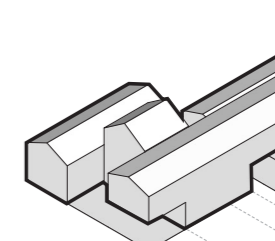
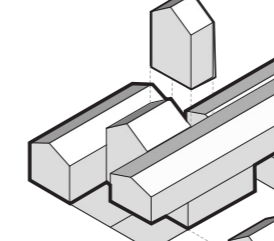
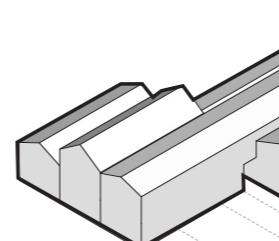
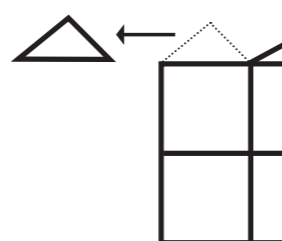
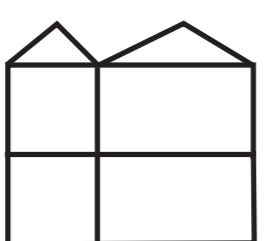
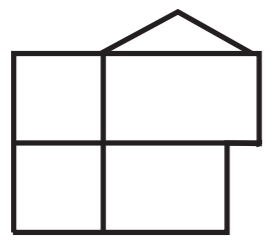

Continuous sections

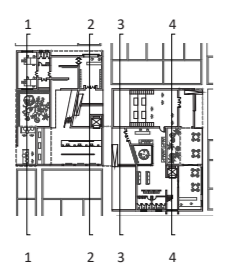

Section 1-1

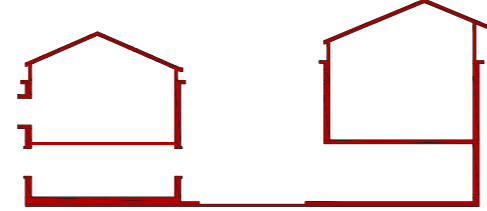

Section 2-2

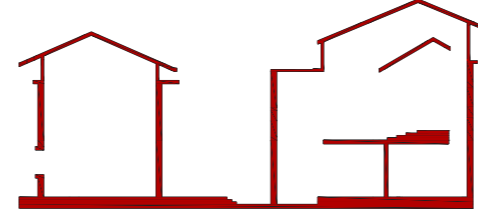

Section 3-3

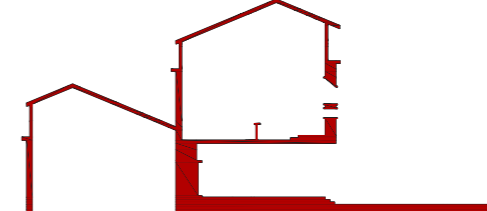

Section 4-4

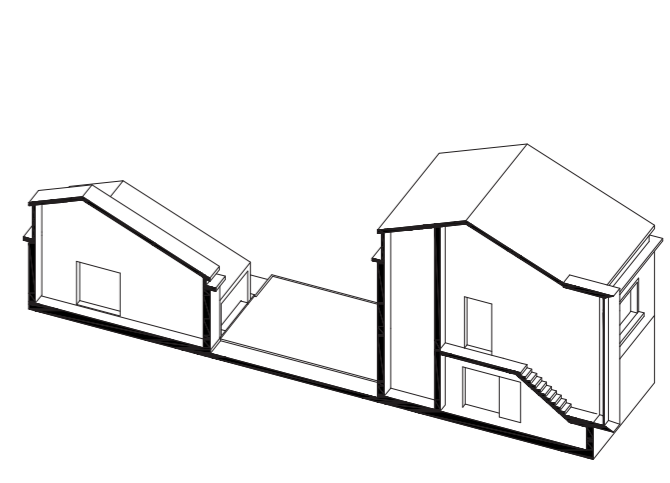
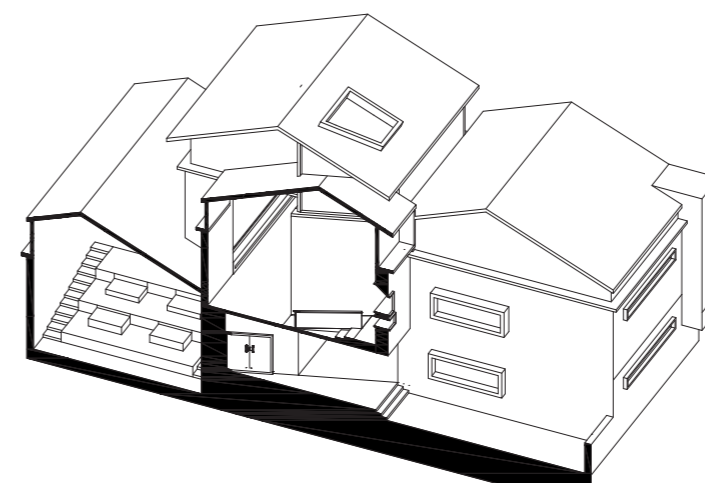
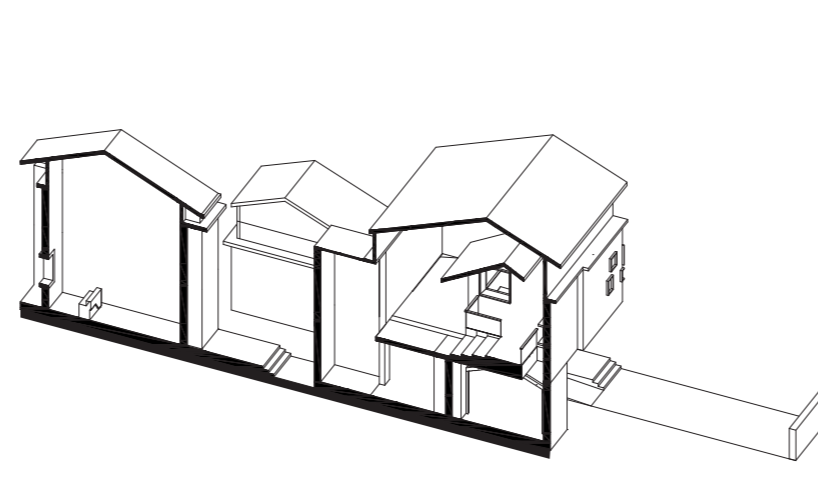
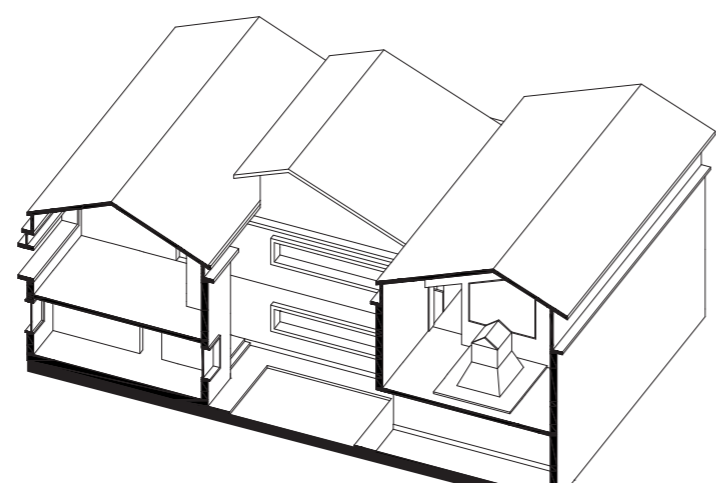
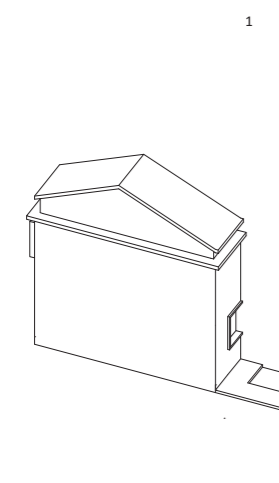
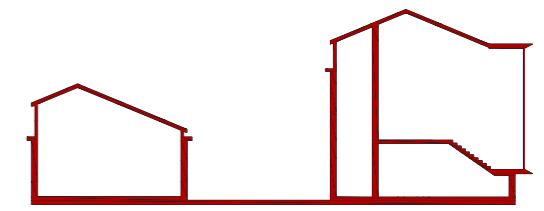

Board IX Contemporary use of traditional materials



Used as a roofing material



The color of the wooden material is more vivid than that of the gray bricks. The design places it at a high place on the facade to connect the gray bricks and tiles. The wooden material placed on a high place can attract the sight of surrounding tourists. Because the price of wood is relatively low, most of the interior furniture is also made of wood.

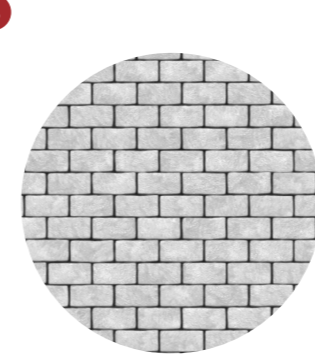

Used as the main material for the facade walls and a small number of internal non-load-bearing walls.

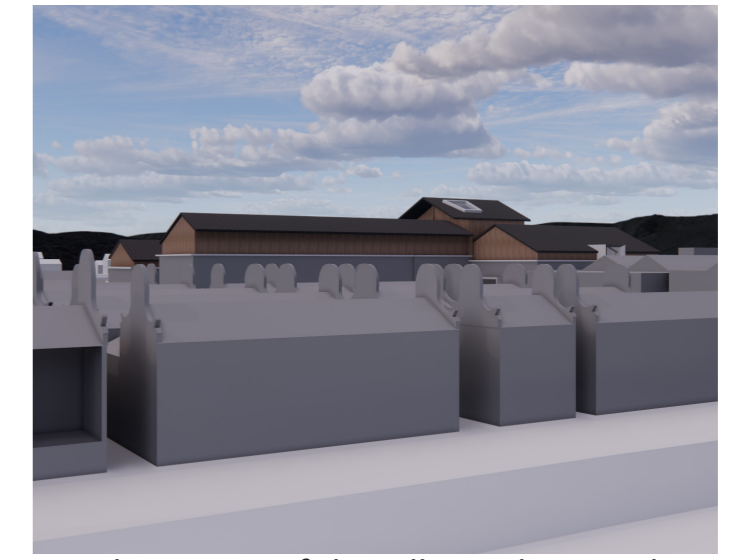

As the center of the village, the wooden facade can be seen in every corner of the village, attracting tourists.



When approaching the building, it is found that the wall material is gray brick like the surrounding buildings. This building can be integrated into the existing building complex.

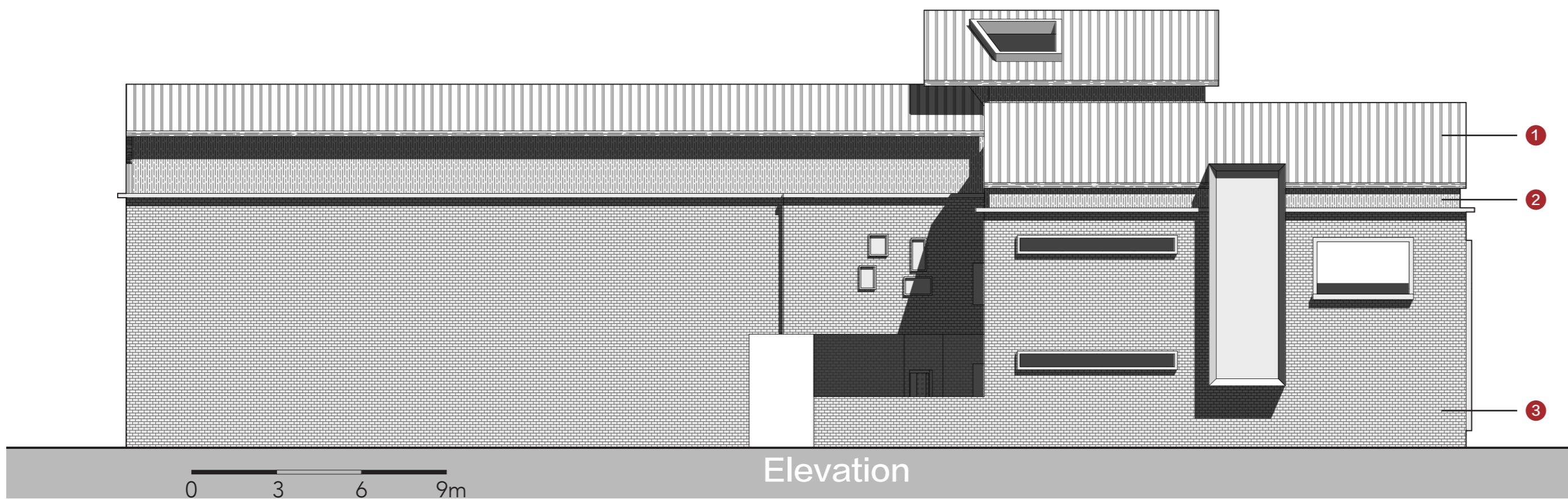

Elevation

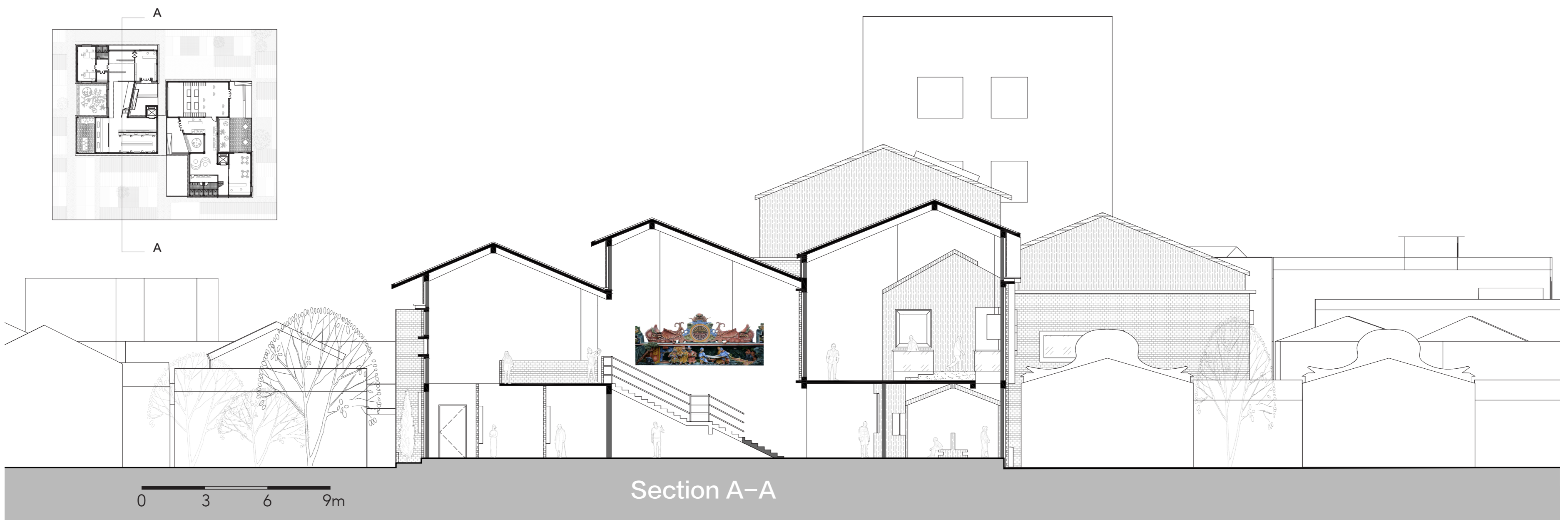
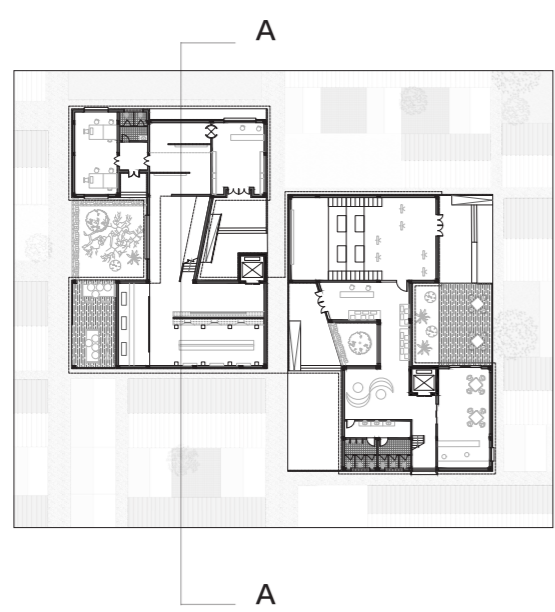

Section A-A

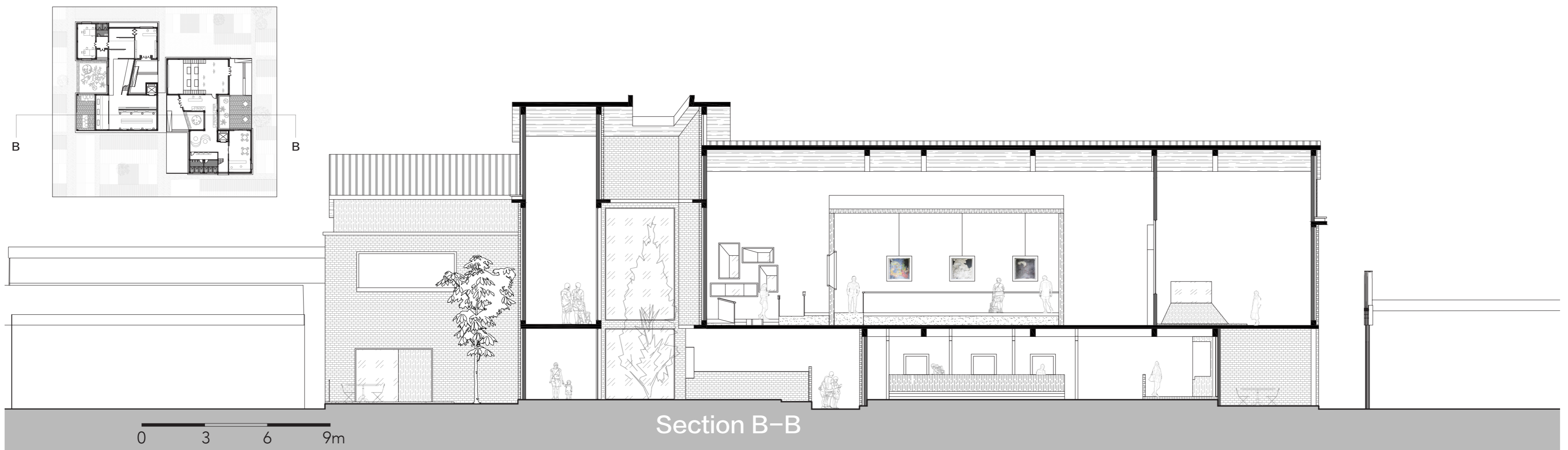

Section B-B

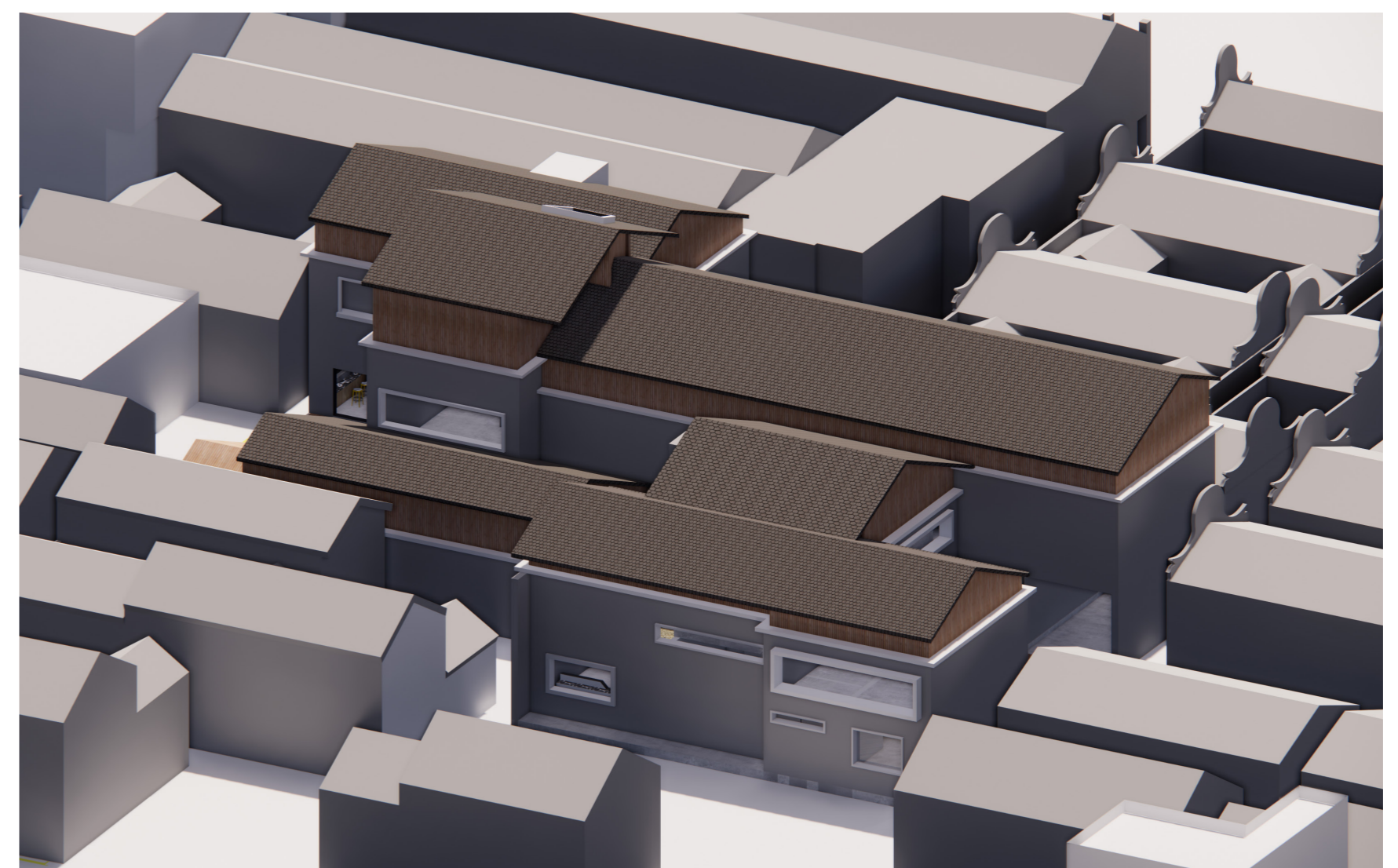
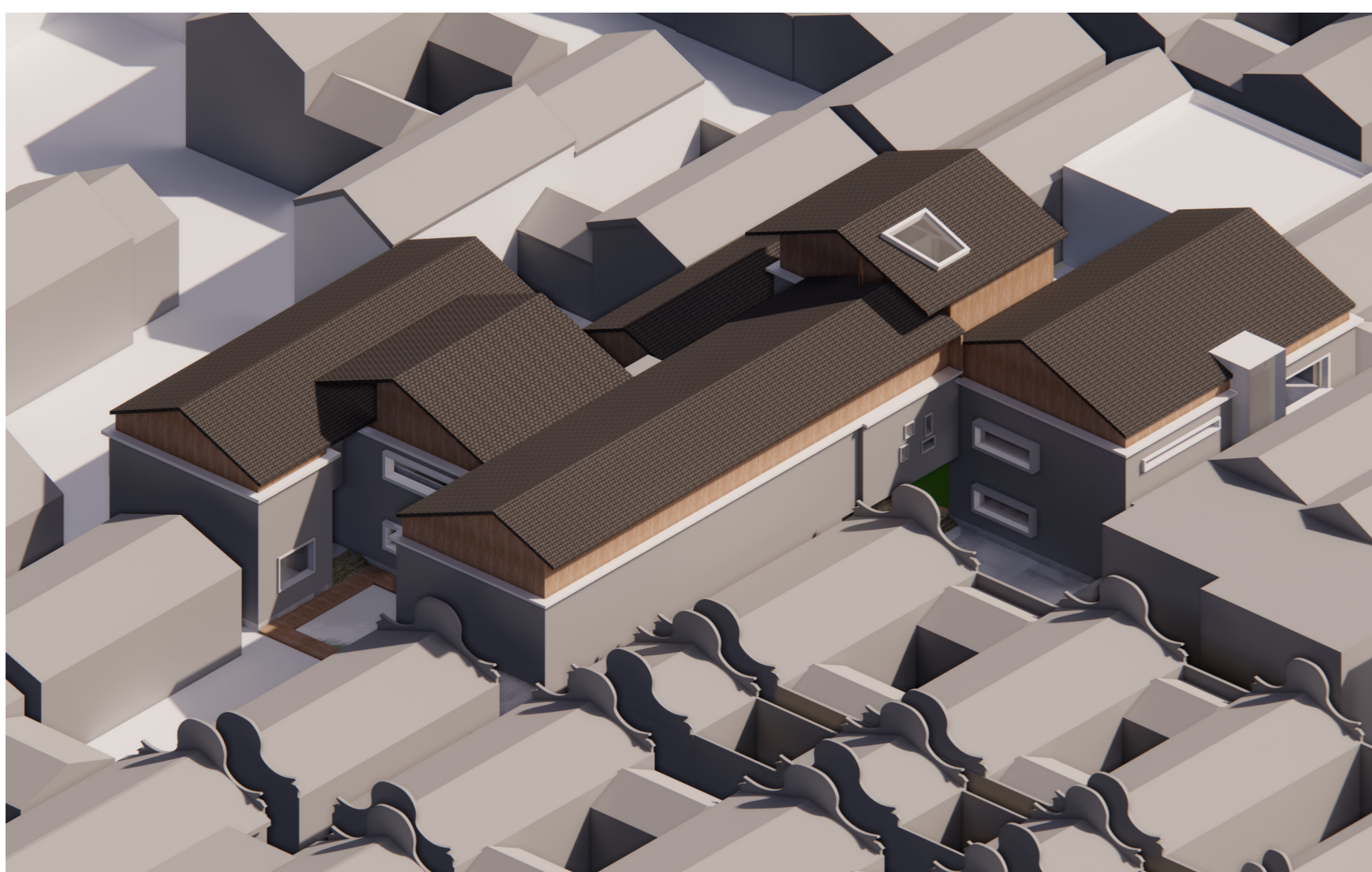

POLITECNICO MILANO 1863

AUIC School A.Y. 2022-2023