

THE HISTORICAL IDENTITY OF VILASSAR DE MAR

Urban development of a city in close relationship with its rural context

Cases de cos

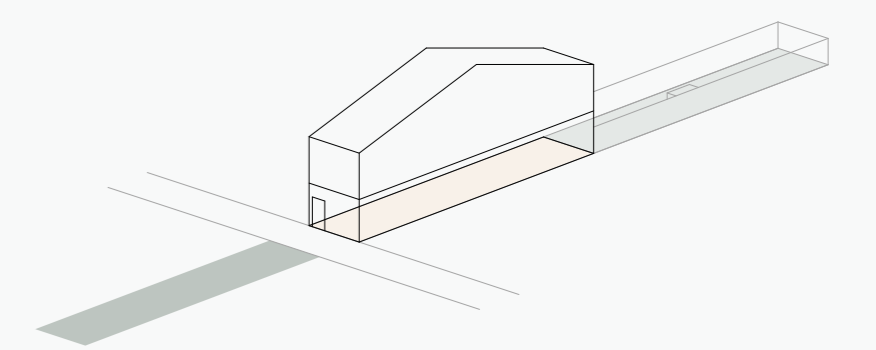
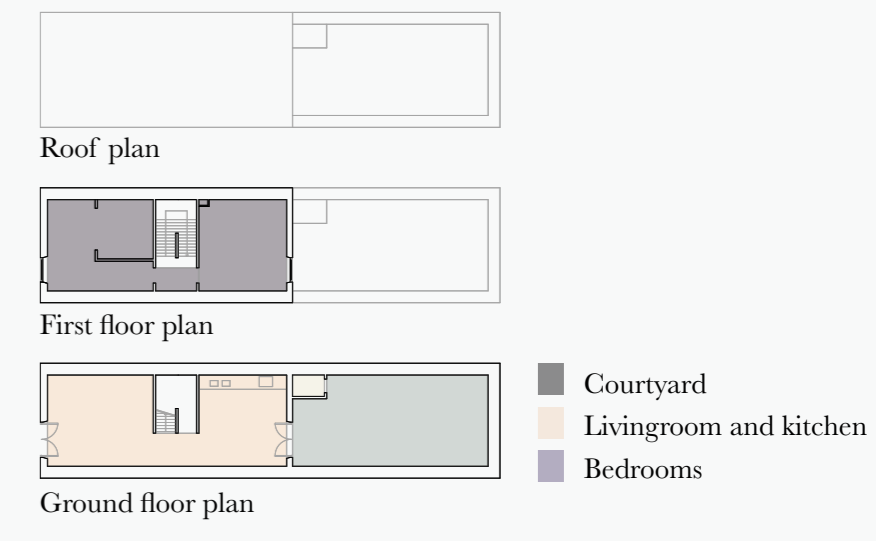

1. Typological diagrams of a *casa de cos*, typical house constituting the historic centre of Vilassar de Mar
2. Riera (torrent) of Cabrils: connecting the historic towns of Vilassar de Mar and Cabrils (until 1750)

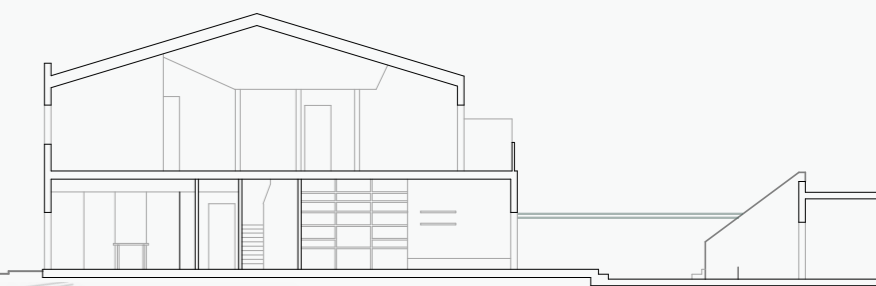
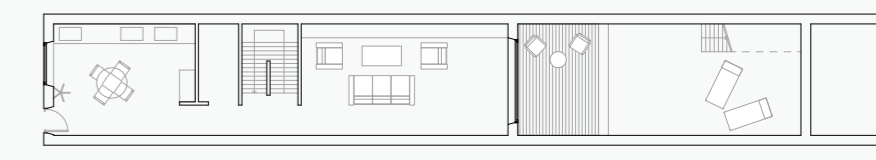

2

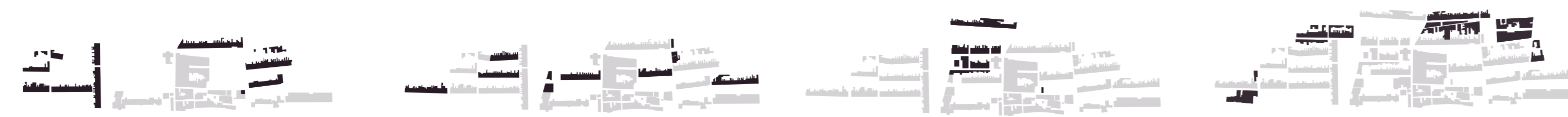

First constructive phase
1750-1814

Second constructive phase
1814-1836

Third constructive phase
1836-1848

Fourth constructive phase
1848-1860

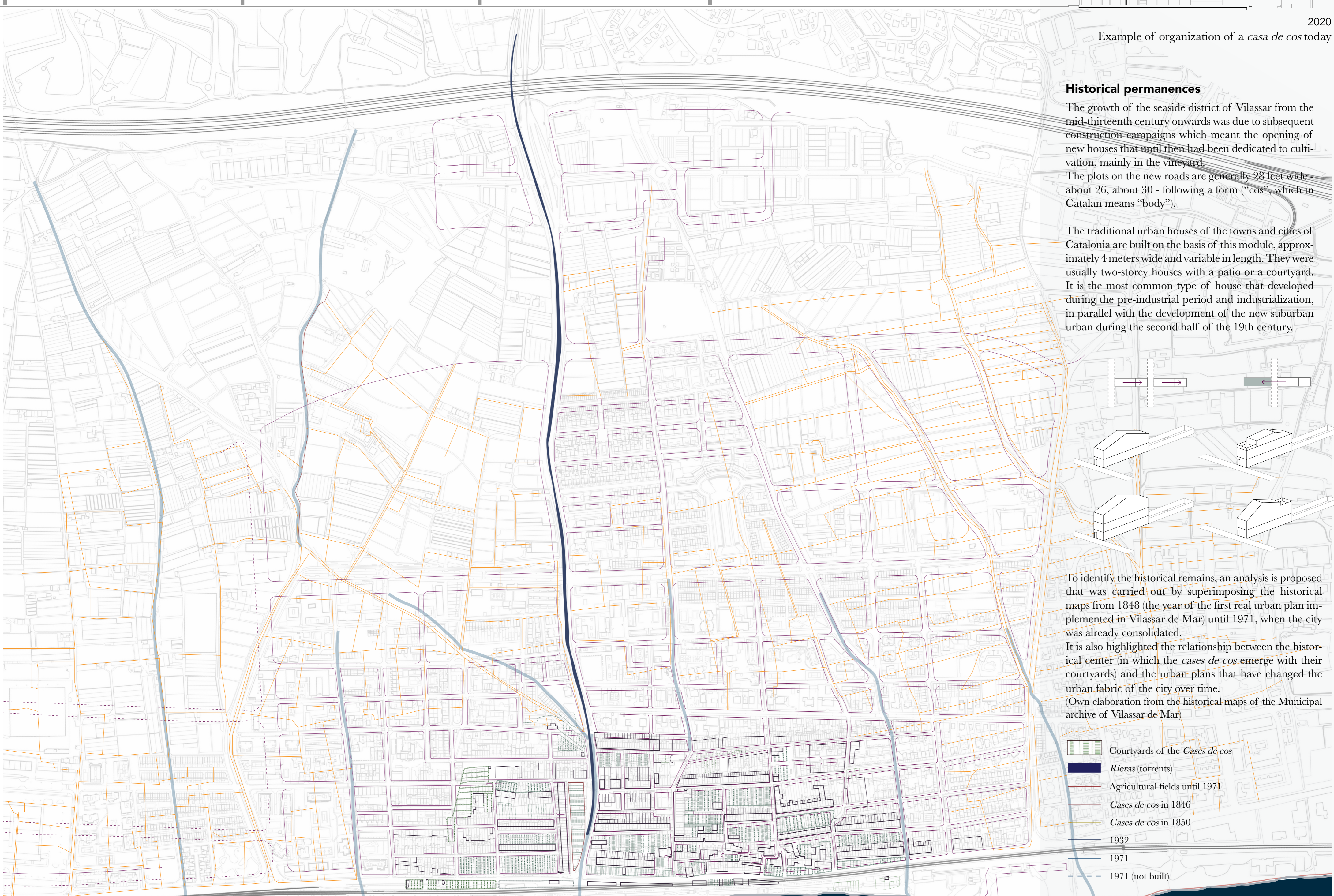

2020
Example of organization of a *casa de cos* today

Historical permanences

The growth of the seaside district of Vilassar from the mid-thirteenth century onwards was due to subsequent construction campaigns which meant the opening of new houses that until then had been dedicated to cultivation, mainly in the vineyard.

The plots on the new roads are generally 28 feet wide about 26, about 30 - following a form ("cos", which in Catalan means "body").

The traditional urban houses of the towns and cities of Catalonia are built on the basis of this module, approximately 4 meters wide and variable in length. They were usually two-storey houses with a patio or a courtyard. It is the most common type of house that developed during the pre-industrial period and industrialization, in parallel with the development of the new suburban urban during the second half of the 19th century.

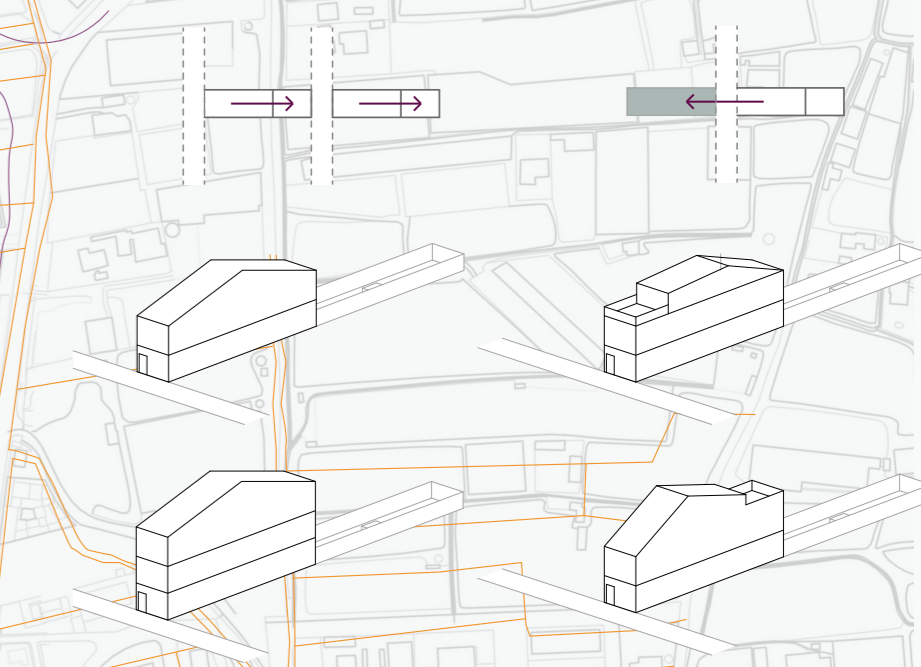

To identify the historical remains, an analysis is proposed that was carried out by superimposing the historical maps from 1848 (the year of the first real urban plan implemented in Vilassar de Mar) until 1971, when the city was already consolidated.

It is also highlighted the relationship between the historical center (in which the *cases de cos* emerge with their courtyards) and the urban plans that have changed the urban fabric of the city over time.

(Own elaboration from the historical maps of the Municipal archive of Vilassar de Mar)

