

**The First Action.**  
The founding act of the composition of Hadrian's Villa.

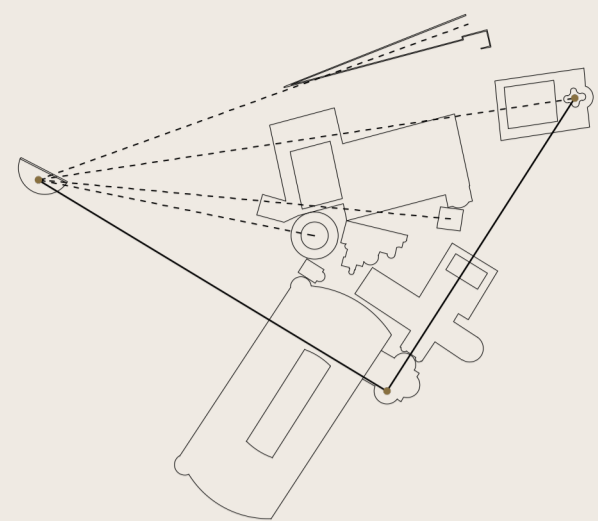

**The Second Action.**  
Displacement of the main hypocaustic center from Temple of Venus Caidia at the Golden Square.

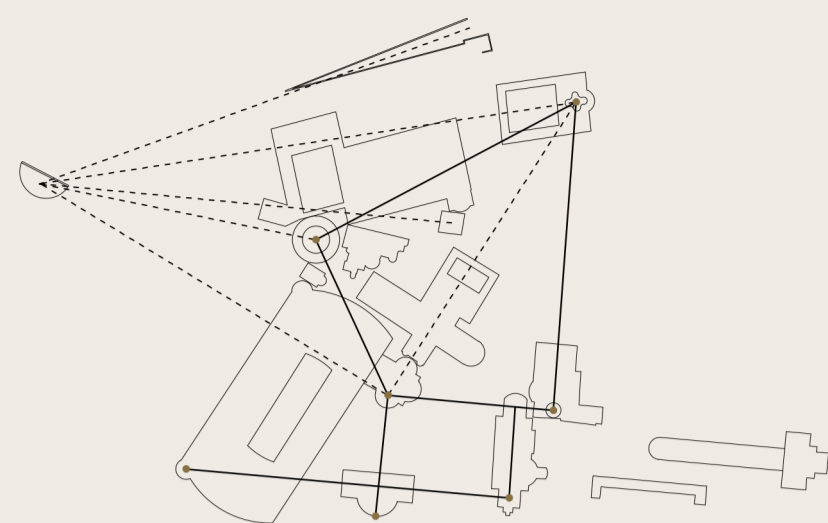

**The Third Action.**  
Introduction of the Axis of symmetry of the Great Baths and activation of the perspective of the Canopo and the Great Vestibule.

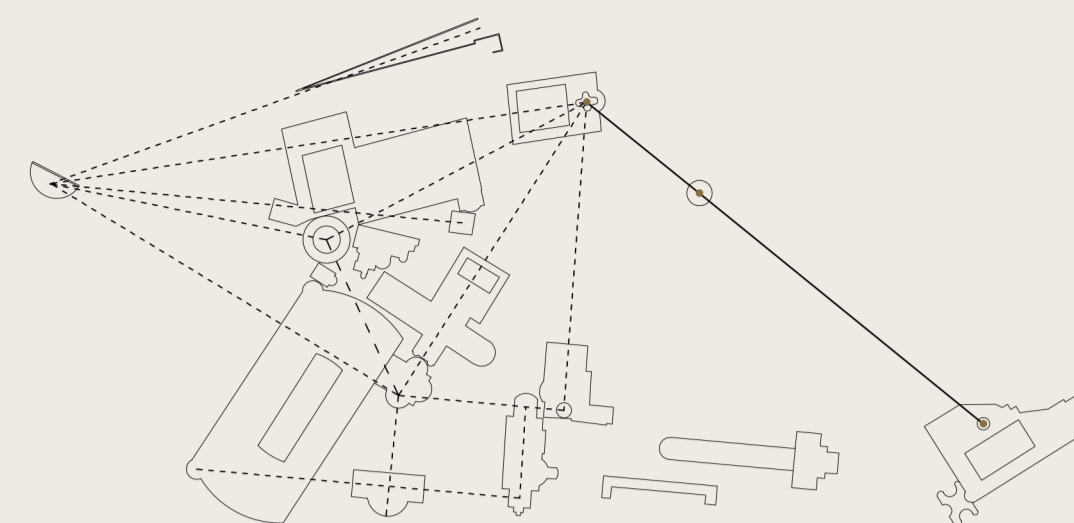

**The Fourth Action.**  
Introduction of the polycentric axis passing through the Rotunda in the Park and centered on the so-called Temple of Apollo.

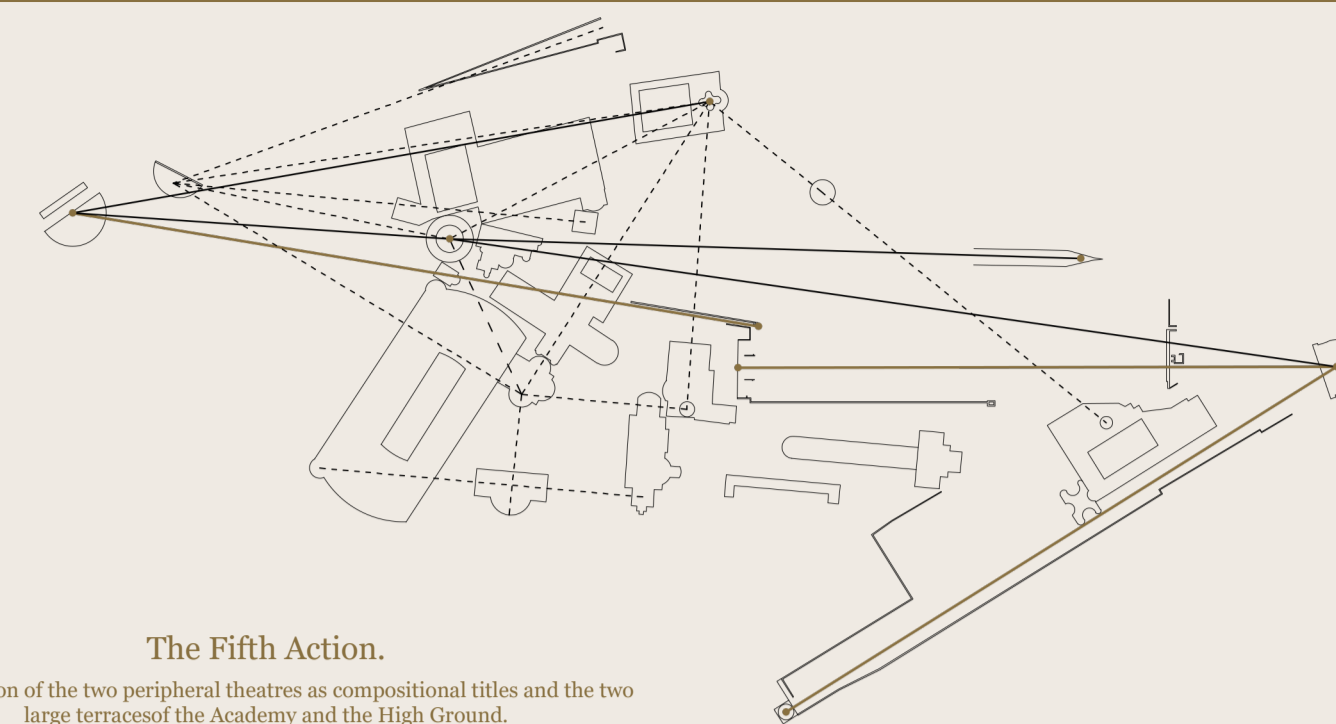

**The Fifth Action.**  
Introduction of the two peripheral theatres as compositional titles and the two large terraces of the Academy and the High Ground.

