



# Project Index

---

Project aim

Page 1- 8

Inspiration

Page 9 - 12

Line development

Page 13 - 77

Logo and Packaging Design

Page 78 - 84

Product shot

Page 85 - 86

Showroom design

Page 87 - 88



The Project of MahaRatu...



## Project Aim

I choose to develop this project in many several purposes. My first purpose is to bring parts of my culture to be known in the foreign western world. The culture of balanced and patience and as well to develop beauty from the simplest thing you can find in life. I found that to emerge this beautiful culture that produces beautiful textile that are capable to be used in the fashion industries and as well will be nicely welcomed by the eastern world. My second purpose is to create a project that meshes both fashion and the compact ability of fashion travelling. There are so many fashion travelers nowadays that want to travel in chicness and comfort. It is very common also nowadays they that they bring gadgets with them to communicate as well along with them to communicate with their clients, friends or family. With this say the demand of gadget bags and accessories are as well booming in the fashion world



I am developing this project as not only as my dissertation thesis projects but also a start of my career as a young independent designer creating my own small fashion company. The starting collections will start on a series of bags that I hope it will be accepted well in fashion industries. As a starting designer I will open my first showroom in Bali Indonesia, in which closer to my resources from the local weavers, and also to my other resources of material and labor to create this bag. I choose to base my showroom in Bali not only because of the closeness of my resources, but also to the fact that Bali is one of the most visited vacation spots. I believe that setting my showroom here could attract tourists (International, and domestic) to view the merchandise that I have to offer for them to travel in style.

# Folklore



## Brand knowledge

The name of the brand that I chose to start this project is MahaRatu. Consists of two different Indonesian words which means “Maha” as the highest and “Ratu” which means queen, If we put these words together It is means The Highest Queen. I chose this name for the brand because from the first process of developing these bags I handpicked from the beginning of the yarns that are used to weave the motifs of the patches, the material that is use to develop the bags such as the high quality of leather and good quality canvas. I as well handpicked each accessory to adorn these lines of bags to be developed from the metal foot, selections of chains and buckles as well for closure and zippers to complete the collections.

I would like my customer whom purchase this line of merchandise to have the fine’ qualities from these bags and to feel satisfy as they purchase these bags, as they are the “MahaRatu”. For the first launching of the series lines of Folklore from MahaRatu I am introducing the series of bags that is inspired from the folklore of the Hinduism of Bali, for this reason I call my first collections of bags with the name Folklore. These bags will tell the folklore that I have learned from the priestess during my weaving session and my meditation in Sidemen Village Bali.



To expand the customer brand knowledge about the new upcoming project, for starter I will only set up one showroom in Bali for starters and hopefully will add more as the company will grow forwards. As to market the company to be more well known I will use the technology of the latest social media. By creating a profile page in facebook and allowing to accepts merchandise orders from the internet orders. Another way to promote the company is to join fashion exhibitions that are held around the world (as a starter I will join the ones that are occurred in Indonesia). The most important Fashion exhibitions and arts and craft exhibitions are held around 4 times a year in Indonesia, which most of them are held in Jakarta the capital of Indonesia. Other smaller fashion exhibitions are as well held in the hotels with higher class in Indonesia which most of them are took place in Bali. Joining these kinds of events will not only make the brand better known but as well to finance the company. One of my biggest goals is to have these bags at Milan Design Week and during fashion week around the world in the biggest fashion city in the world. To promote my brand is not only to promote me as a young independent designer, but also to promote my culture to be more acknowledge more than its beautiful vacation spots, but as well to be acknowledge for its craft and creative artworks that i offer to the fashion world.







### **Strength:**

- new creative invention
- a one of a kind line of merchandise
- well made in good qualities
- offering custom made product,
- As for the location of the work shop, closer to the resources as the main supplier and it will make it easier to communicate with them



### **Weakness:**

- A long time length to develop the merchandise,
- A higher price range which might not be accept to the market
- A smaller target market in range



### **Opportunities**

- The availability to expand more about the brand to go international because of its uniqueness
- A good responds from the market in term of its Design and aesthetics



### **Threats:**

- A knock off copy industry which are common in south east Asia to imitate the ideas and design of the bag
- The high price of Beurocracy of the export policy to expand the company outside of Indonesia



## Target Market

### Demographics

- Gender: Women
- Age: 25 50 years old
- Race: All race of women
- Geographical living: Big cities in the world that accepts fashion involvement
- Profession: Working in a Creative work industry (Designers, fashion travelers, and fashion Practicers)
- Income: 60.000 euro and higher per year

### Psychographics

- Personality: Confidence, Adventurist, creative, and Independent
- Hobby: Traveling, Shopping, Designing, and art related activities
- Style: Glamorous, chic, loves fashion products that combines fashion meets functions.

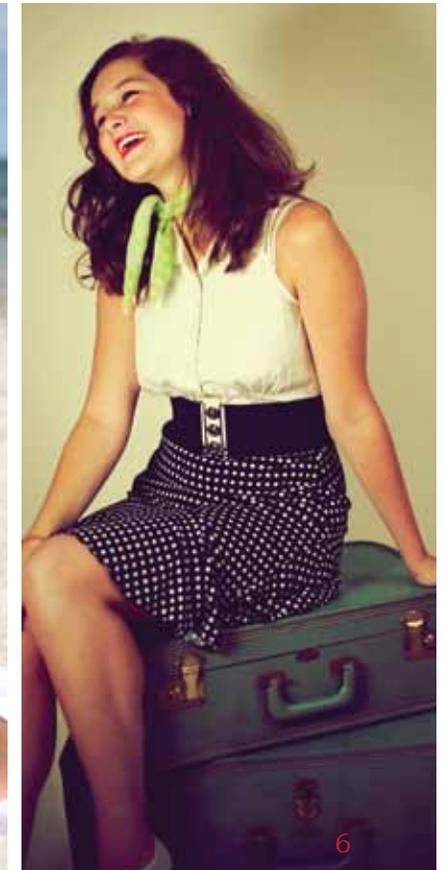

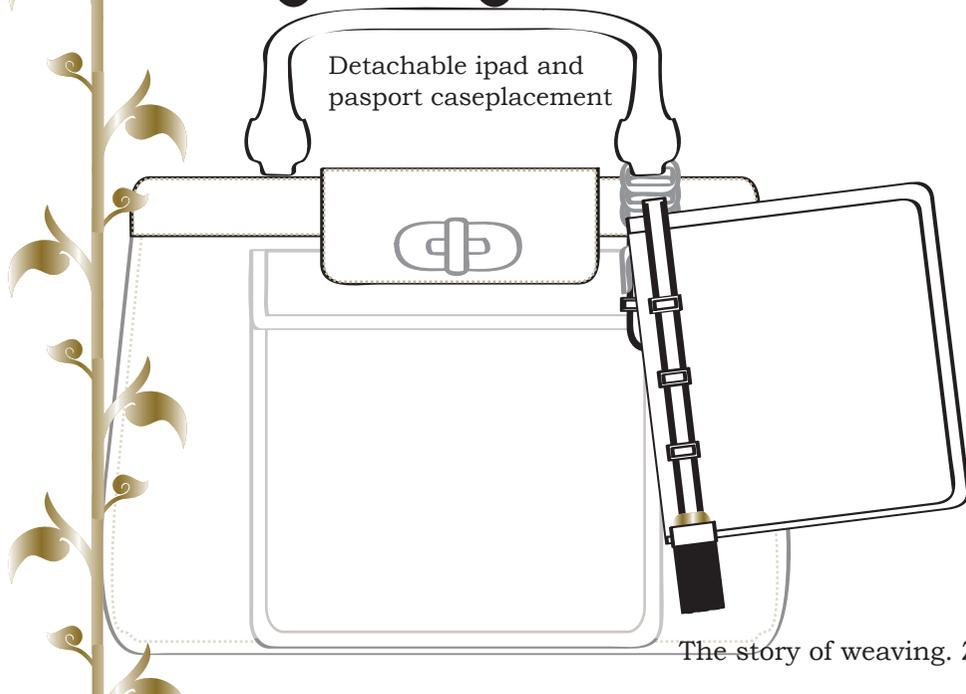
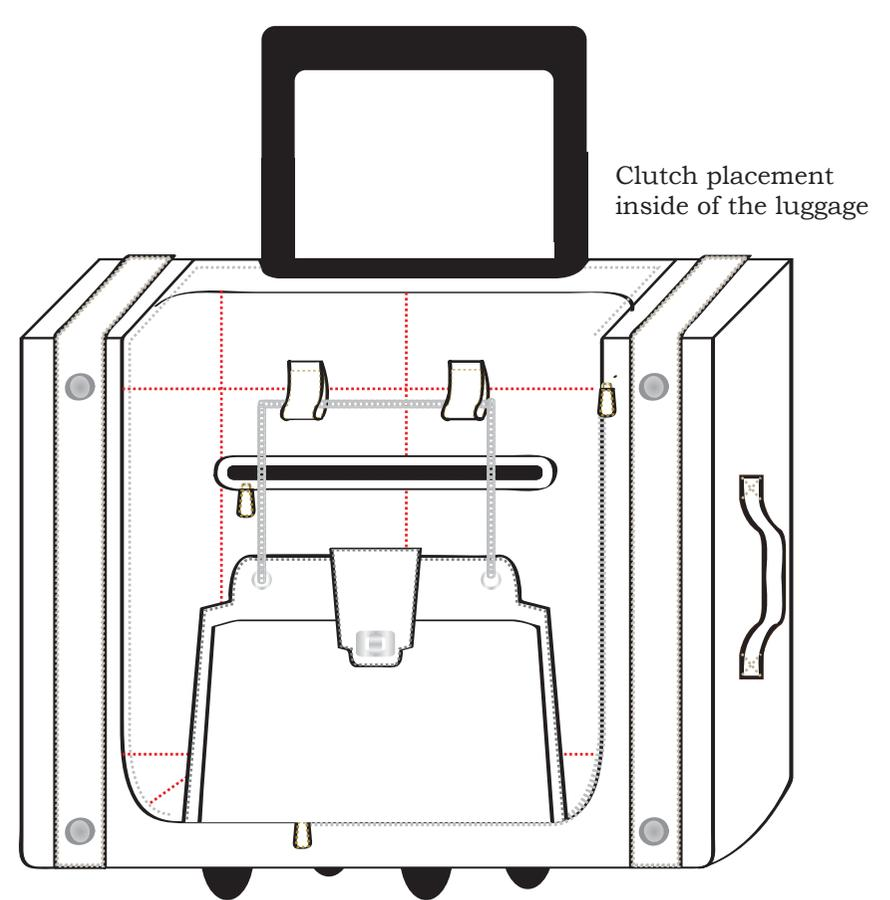

## Project Plan

The lines of bags that I create are in synch with each other and it starts by offering a luggage stroll that can be stored in the luggage or in the cabin area, a shoulder bag that has a compartment inside connected with a hook to attach the detachable I pad bag. A detachable I pad bag that has a storage as well for its charger, and a fancy fashionable clutch that can be attached from its detachable chain to the inside front of the luggage bag. The chain on the clutch is detachable so the clutch itself can be carried without the chain or can be use as a little sling clutches that are also very much trendy nowadays in the fashion world. These series of bags are also will come along with a Passport cover.

Interesting facts about these bags are the ability for it to be worn in a different way. The closure part of the luggage can be flip and use as two ways. One way is to attach the detachable woven patches, and one way where the folklore itself is embroidered on the other side. The customer could choose on which way they want to use this cover. The cover can be detachable by using a detachable zipper that makes it possible to be use this way. For the design of the Hand bag it is as well quite unique. The hand bag will have a zipper on the side part that could be able to open and change to its reversible side. For the handle of the bag I am using buckles as a media for it's to be attached and detach on both main and the reversible side. For the closure of the hand bag it could be attach and detach as well using snap buttons on both main and reversible sides. I added another snap button in the middle part to attach the detachable belt to connect between the bag with the I pad case.

On the I pad case the front part will as well be reversible. As the same as both the hand bags and luggage on the main part the customer will be able to attach the magnetic patches, and on the reversible part it will told the story of the folklore. For the clutch I am making the front part to be the part in which they can detach and attach the patches, as the back part it will show the embroidered story of the folklore. The clutch is completed with a detachable chain that could be use or not. The chain is also created as a connector with the inner fabric loop that I create on the luggage. As for the last merchandise I created a passport holder with a detachable strap that could be attach or detach to the chain part of the hand bag.

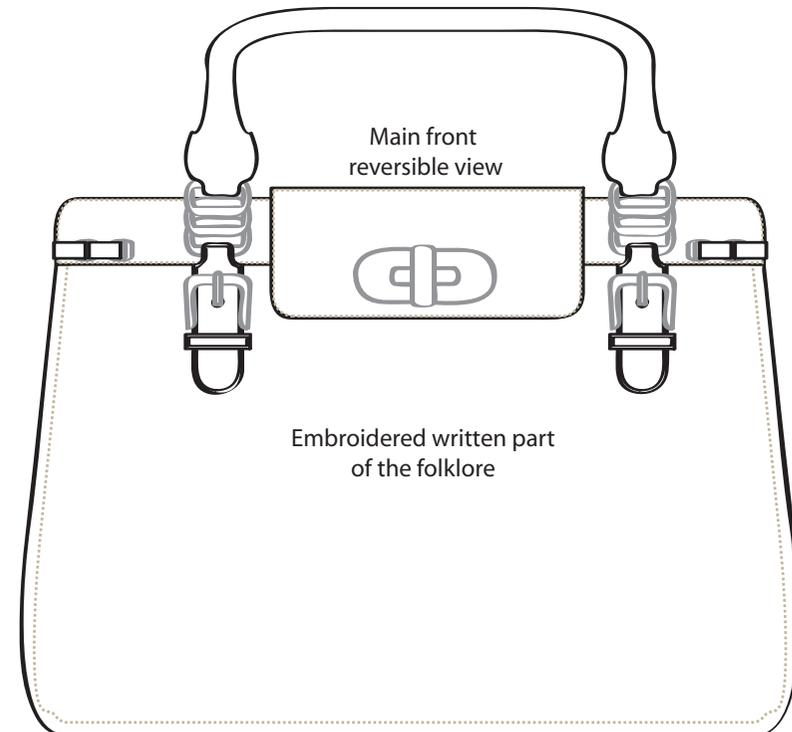
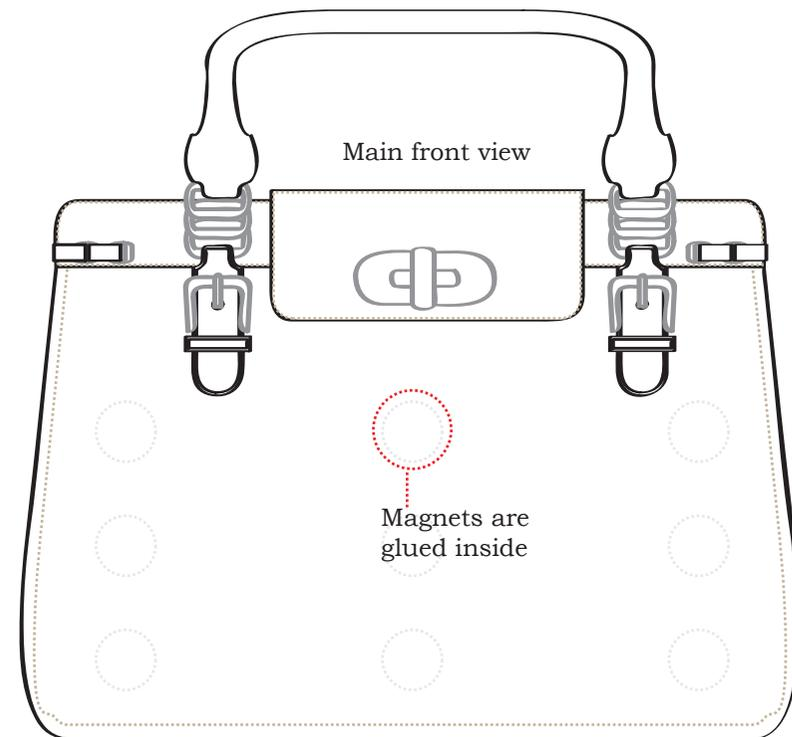

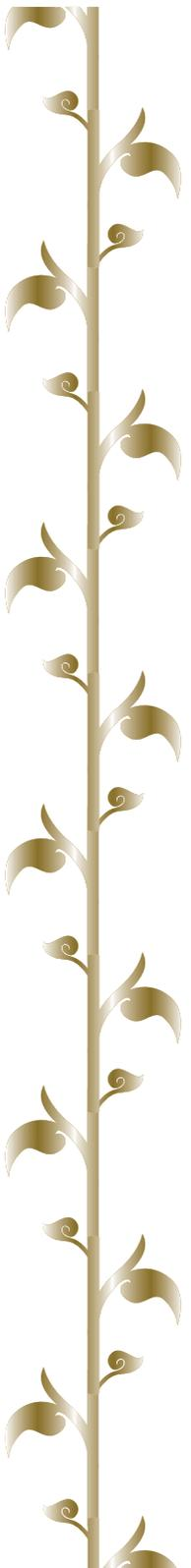

Inspirations...

## Inspiration

Inspired by the closeness of the priestess's family here in sidemen village, Bali, by the humble and simple life style that the thought me through balanced and patience to create an elaborate beautiful songket, I focused my thesis projects on developing more on how to make the motifs they use on their songket more well known to the western world. As I stated on my previous research that the songket in Bali is the only songket that actually has an articulate motifs of the gods with the story of epics Hinduism folklore. Using these bags as a frame of part of the scene that was told in the Hinduism folklore that I was told during my stay with the priestess, I choose the motif that connect them together and try to show them in one line of bags as their media to tell these stories. I chose the folklore of Ramayana, Batarayudha, and Nagatoya. As for my other two lines of bags I chose the theme of Sesajen which means the offerings in Hinduism, and Puresuci which means the sacred temple.

Starting from the inspiring lesson of patience and balance I combine two colors of yarns together to create different effect to the woven base before the woven patches is added with the various decorative yarns to shape the motif I choose. The two interweaving yarns together will create another new color signified the combinations of how patience and balance can create intricate beauty. I handpicked the 14 different color yarns inspired by the everyday life I see here in Bali from its arts and craft intricacy, from the beauty of their landscape and from the beautiful cloth that they produce here.

To start developing these lines of bags my idea was, Instead of using the whole cloth of the songket I am using cuts of the motifs that are meaningful and weave them separately. Later on these motifs will be cut as patches that can be attached and detachable. The cut patches of motifs will be covered and stitch with genuine leather and at the back of these patches I will attach an invisible magnets on both part of the bag and the patches as devices for them to be detached and attached. To complete the placement of these beautiful patches I am designing a series of bags. I am developing a fashionable line of all in one travel bags. These bags are consist of a strolling carryon luggage, a shoulder bag, and I pad bag, and a clutch that we can wear to carry only the things we need to go out at a night life in a town. Inspire by the closeness from Mrs dayu purniari's family that lives in the same compounds with her, I designed The placement of these bags to be clustered in side of the strolling carryon luggage. As I am also inspire by the simplicity of comfort of their life I believe that as a fashion traveler that will use these bags they want both in terms of beauty meets with functions with the bags that I created. These bag are very comfortable to bring and very easy to store as well.



Culture

Reversability

Leisure

Folklore Mood 10





Gold  
Pantone 8644 C



Light brown  
Pantone 732 C



Dark Yellow  
Pantone 703 C



Blue  
Pantone 2758 U

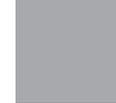

Silver  
Pantone 877 C



Grey  
Pantone black 7 U

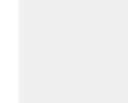
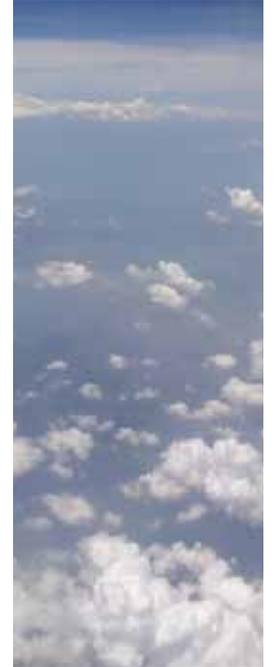

White  
Pantone cool  
grey 1 C



Cream  
Pantone 100 U



Dark Brown  
Pantone DS 324-1 C



green  
Pantone 370 U



Black  
Pantone black C



Dark Pink  
Pantone rubine  
red C



Red  
Pantone 188 C



Dark Red  
Pantone 195 U

**Yarn colors**  
12



Line developement  
and Technical sketches...

Main front view



Reversible front view

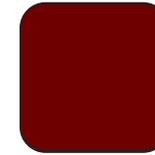

Genuine leather  
Maroon

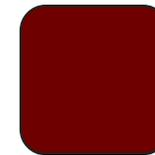

Canvass  
100% Cotton  
Maroon



Canvass  
100% Cotton  
Creme

Right side view

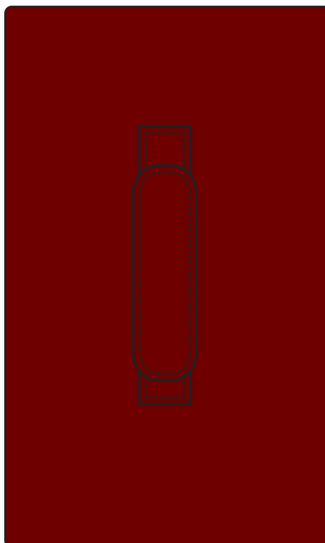

Left side view

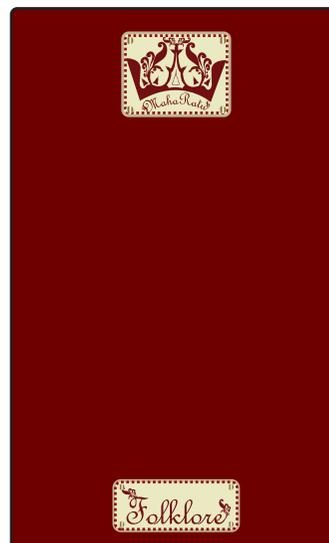

Back View

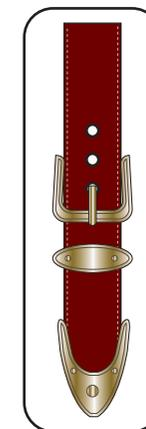

Buckle  
conector

# Ramayana

Main front view



Reversible front view

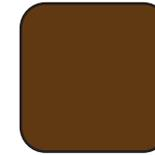
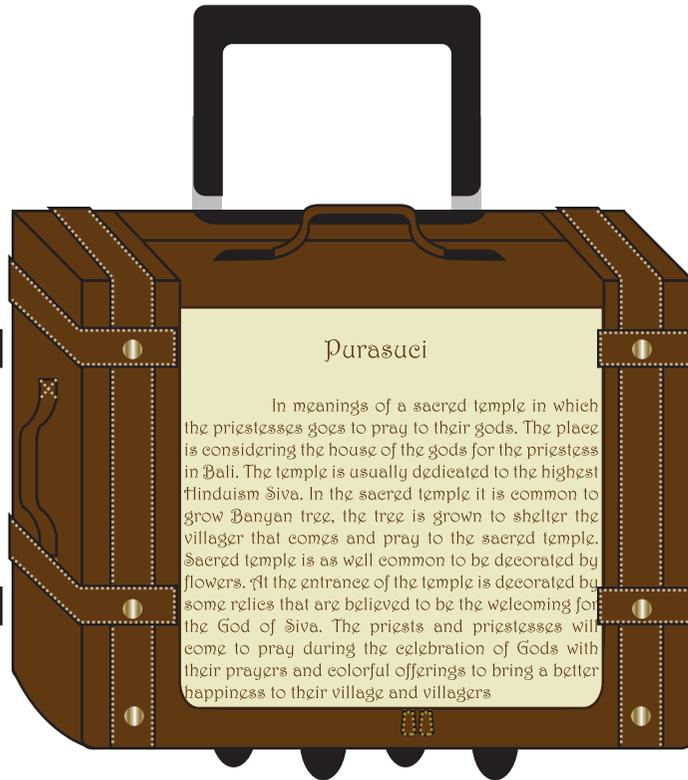

Genuine leather  
Brown



Canvass  
100% Cotton  
Creme

Right side view

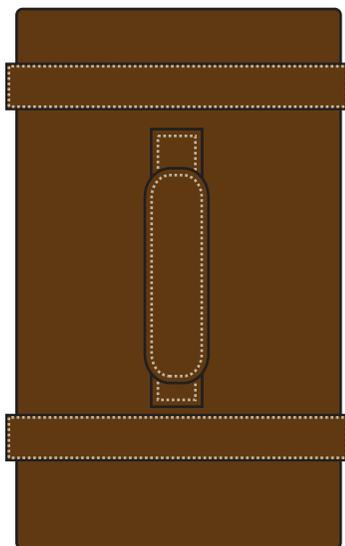

Left side view

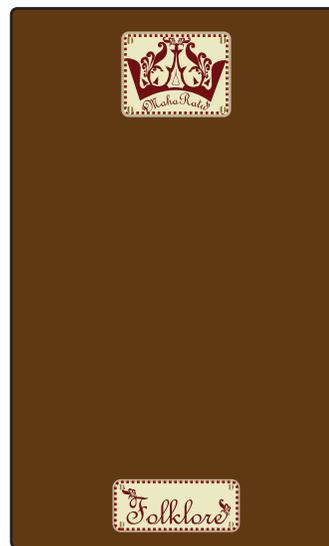

Back View

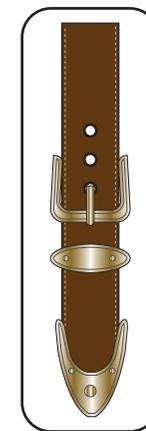

Buckle  
conector

Purasuci

Main front view



Reversible front view

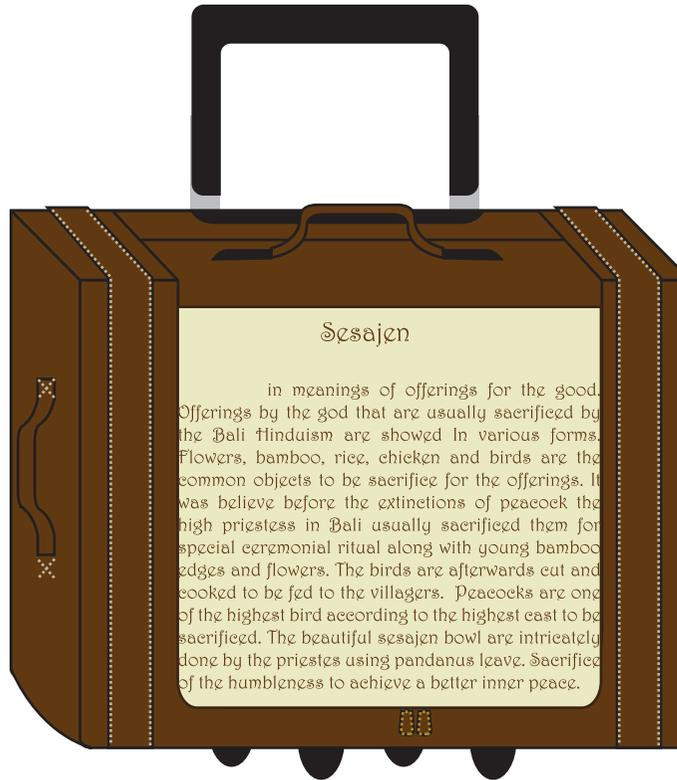

Genuine leather  
Brown



Canvass  
100% Cotton  
Creme

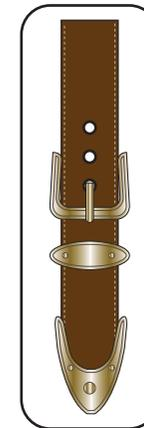

Buckle  
conector

Right side view

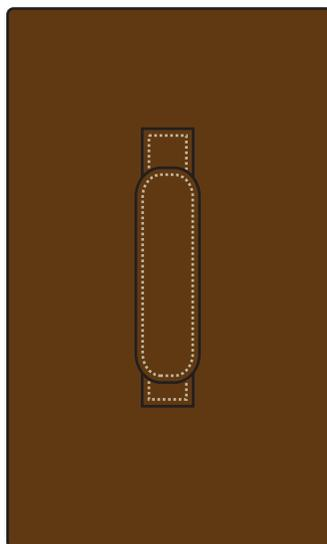

Left side view

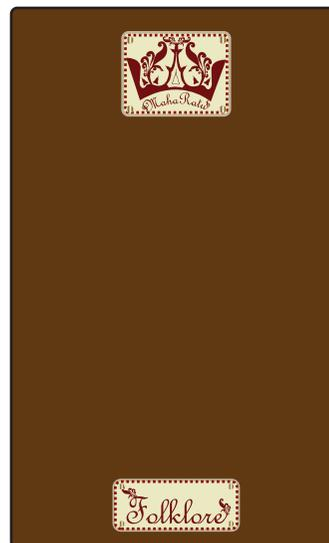

Back View

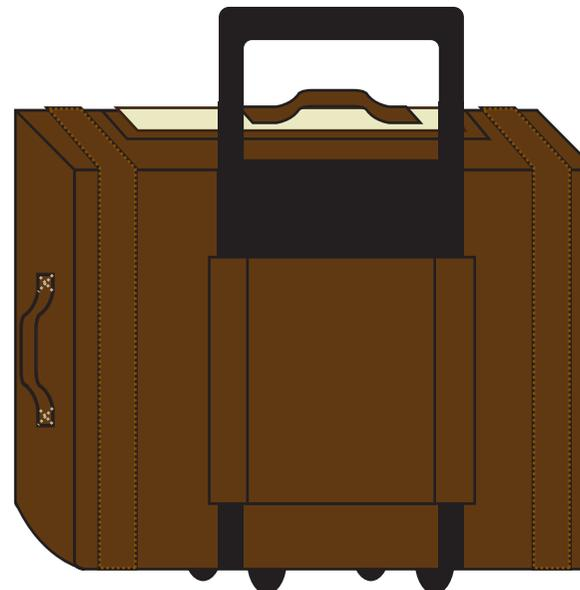

Sesajen

Sesajen  
in meanings of offerings for the good. Offerings by the god that are usually sacrificed by the Bali Hinduism are showed in various forms. Flowers, bamboo, rice, chicken and birds are the common objects to be sacrificed for the offerings. It was believe before the extinctions of peacock the high priestess in Bali usually sacrificed them for special ceremonial ritual along with young bamboo edges and flowers. The birds are afterwards cut and cooked to be fed to the villagers. Peacocks are one of the highest bird according to the highest east to be sacrificed. The beautiful sesajen bowl are intricately done by the priestes using pandanus leave. Sacrificed of the humbleness to achieve a better inner peace.

Main front view

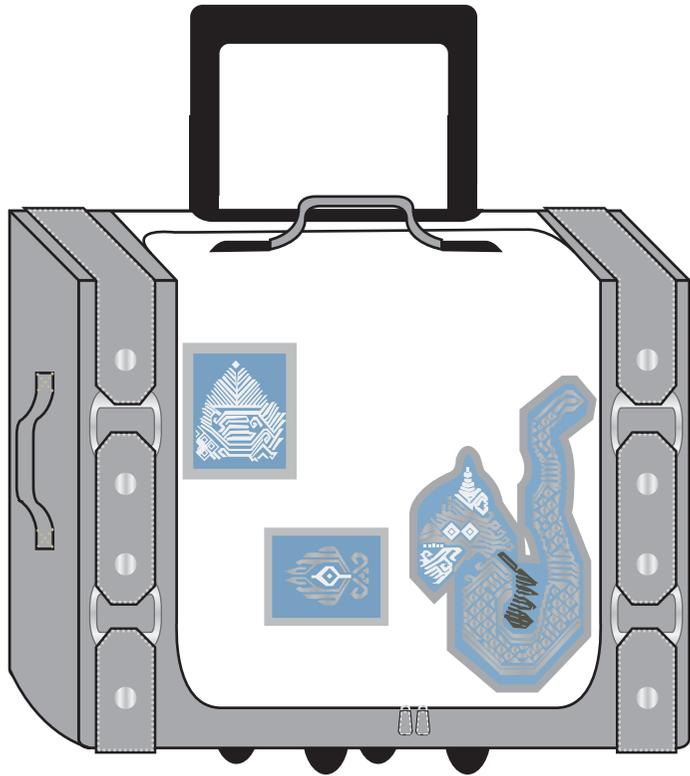

Reversible front view

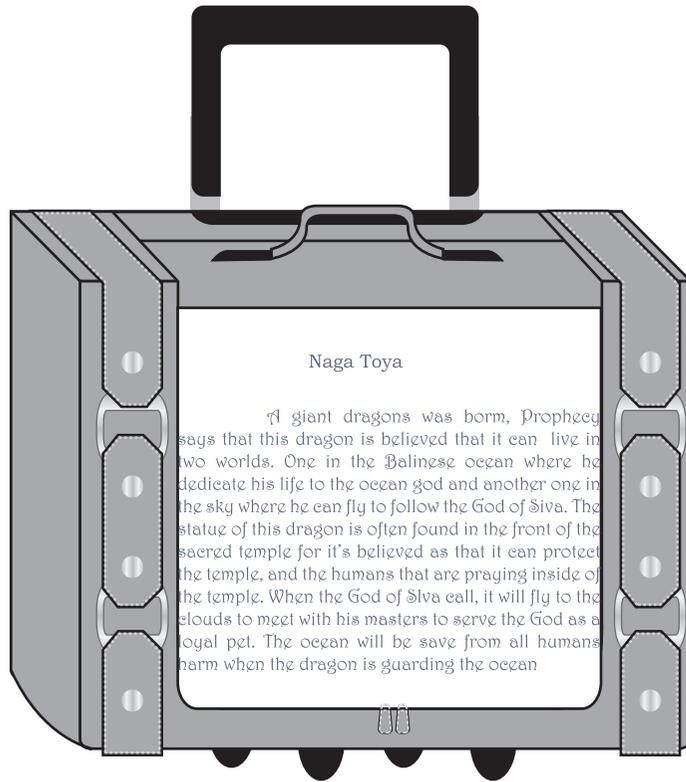

Genuine leather  
Light grey



Canvass  
100% Cotton  
White



Buckle  
conector

Right side view

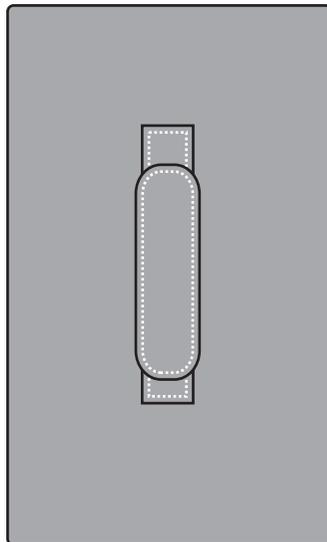

Left side view

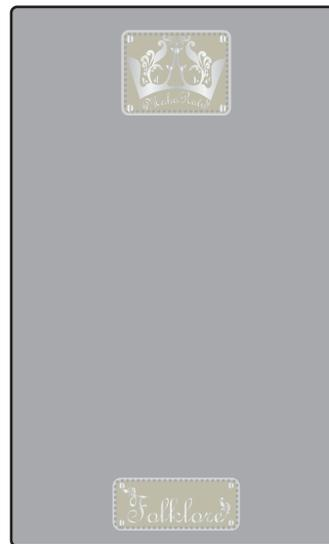

Back View

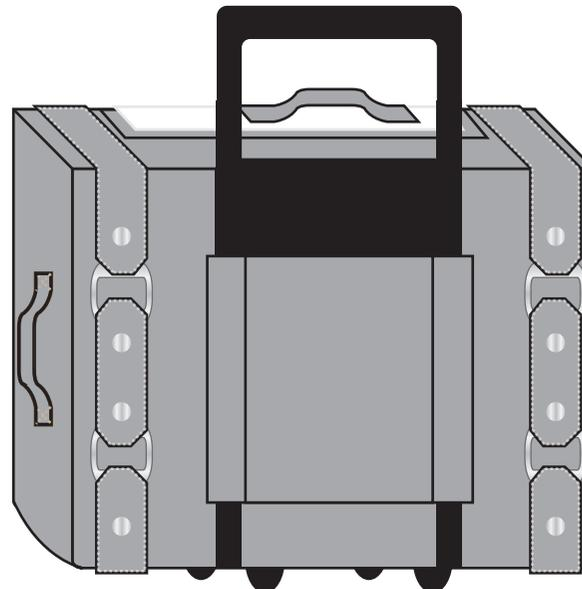

# Naga Toya



Main front view



Reversible front view

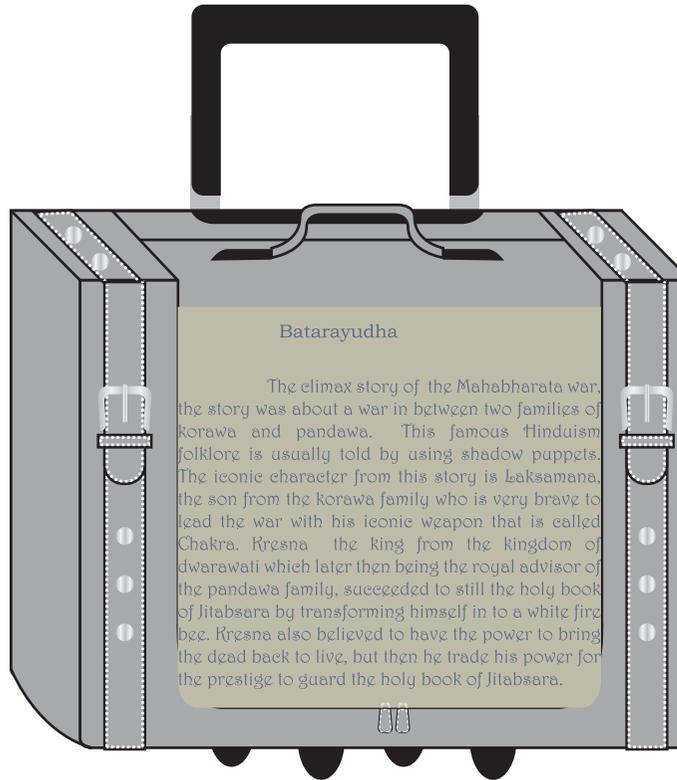

Genuine leather  
Maroon

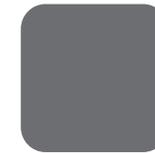

Canvass  
100% Cotton  
Grey



Canvass  
100% Cotton  
Creme

Right side view

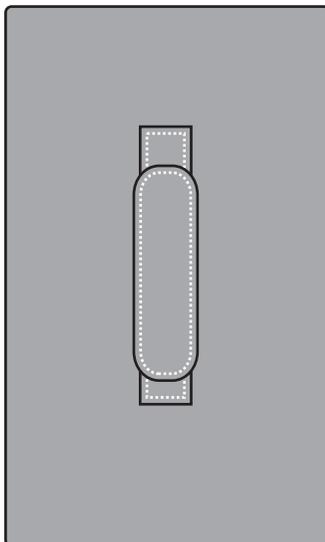

Left side view

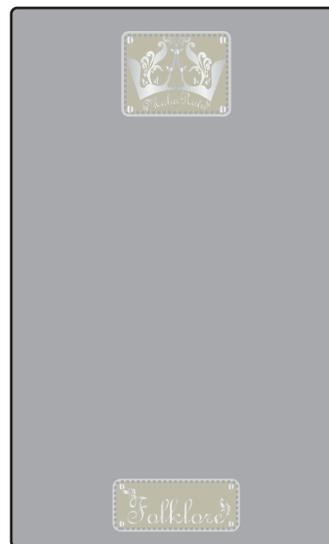

Back View

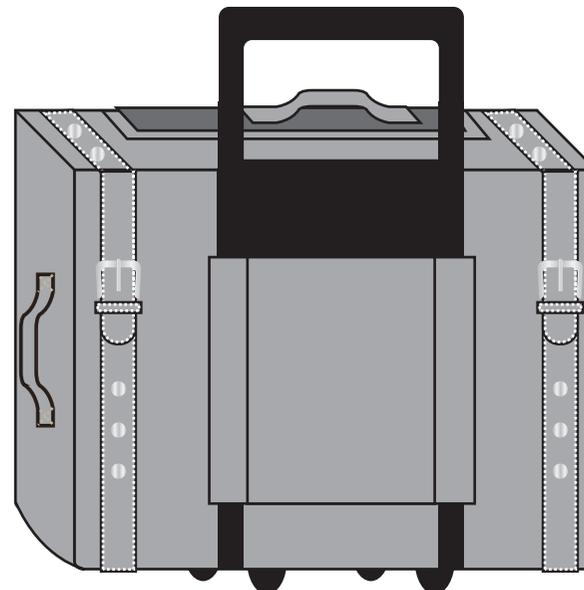

Buckle  
conector

# Batarayudha





Main front view

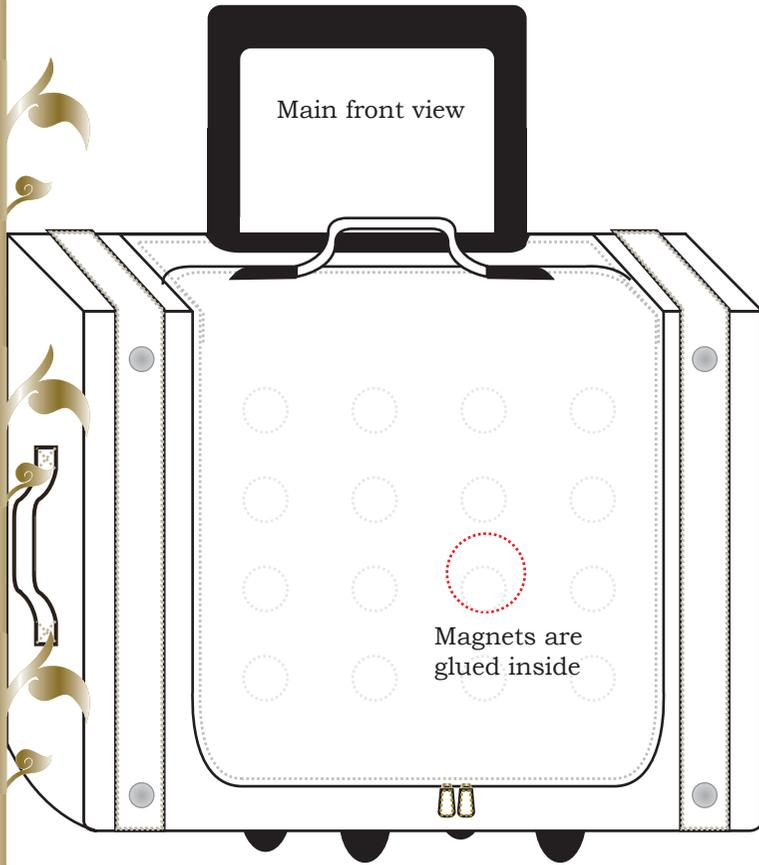

Back View

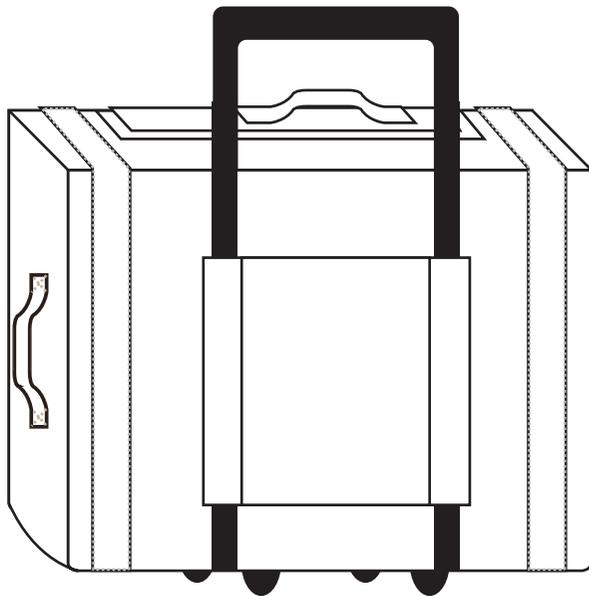

Embroidered reversible side

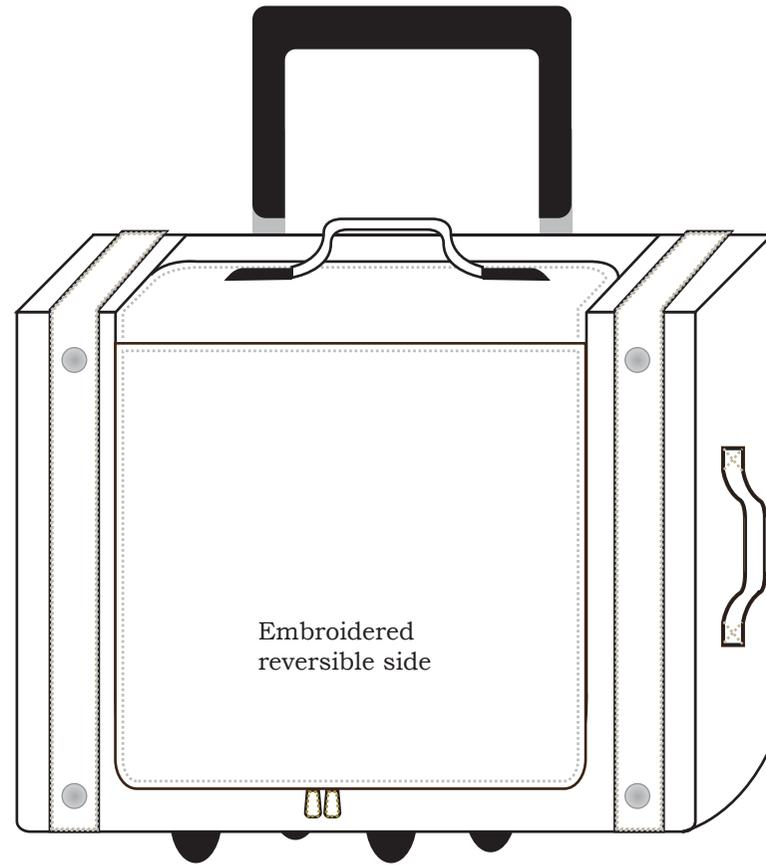

Right side view

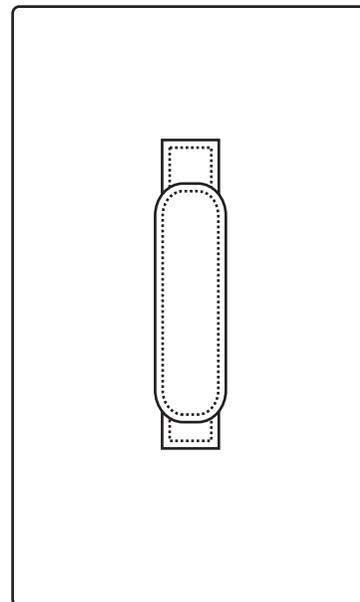

Left side view

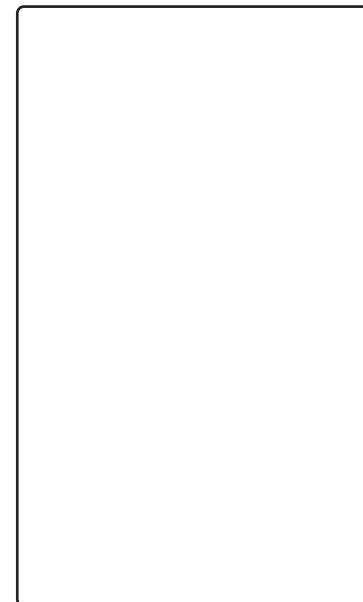

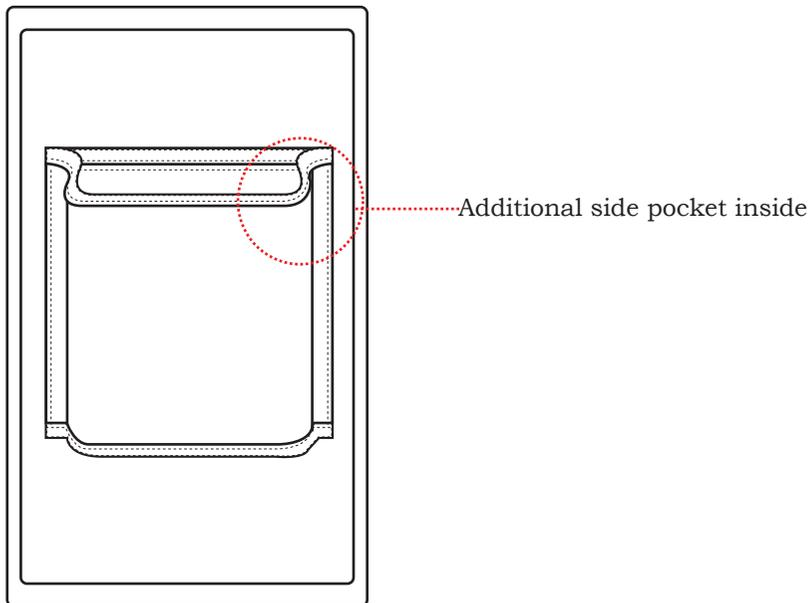
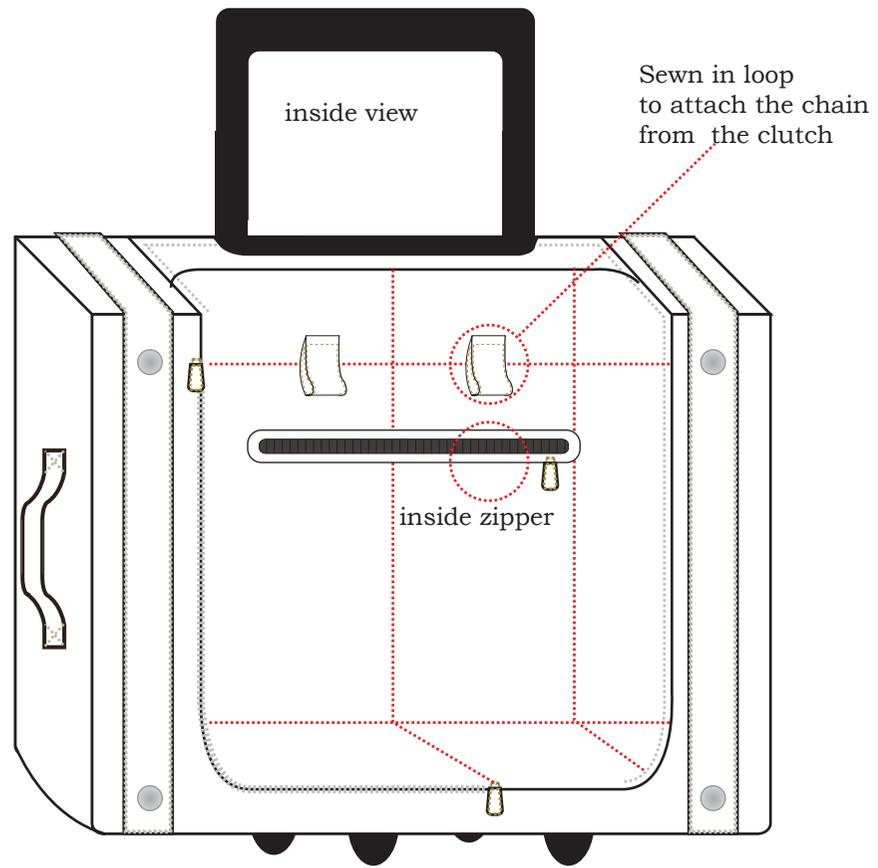
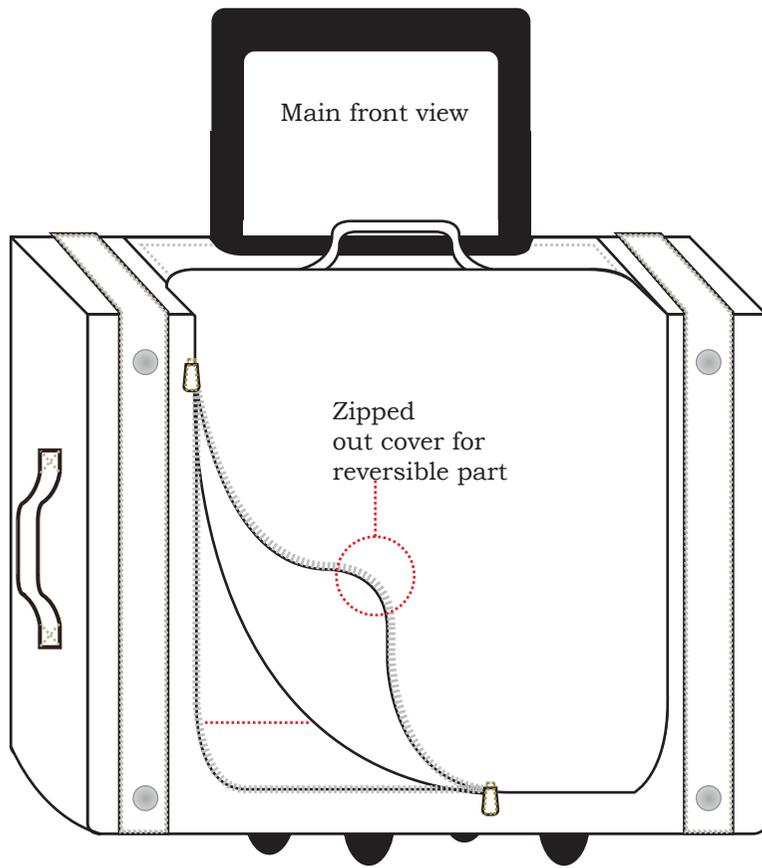

a small belt is use as a connector between one bag to another.

The connector is placed on the inside top handlepart to connect between the hand bag and the luggage by using snap button as a media to attach and detach it.

Main body Size

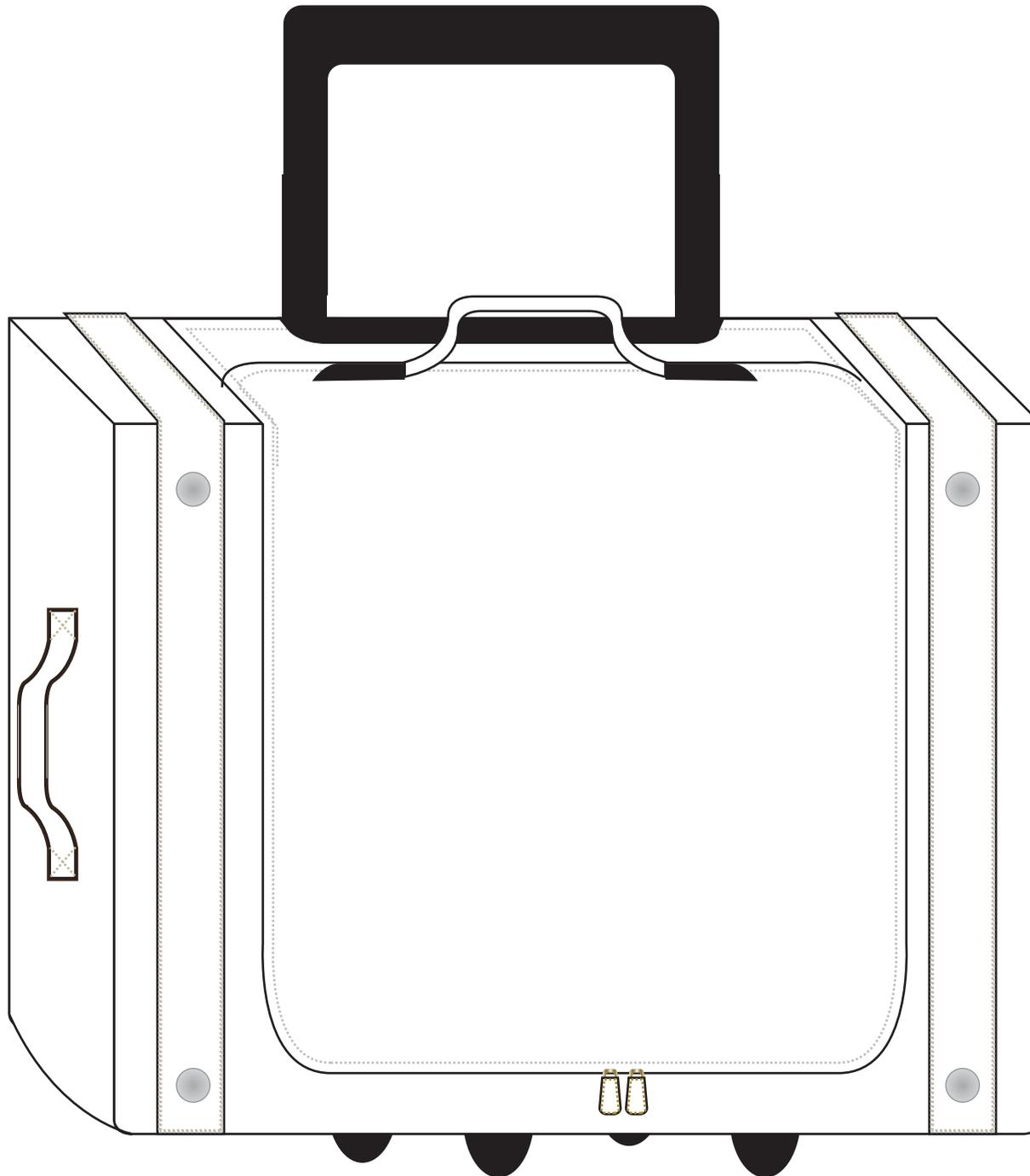

Height: 38 cm  
Widht: 50 cm  
Depth: 23 cm



Main front view



Main back view



Main inside view



Main side view



Buckle conector

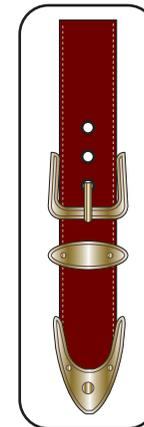

Tassle

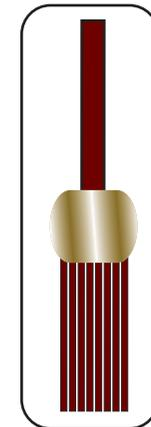

Reversible front view

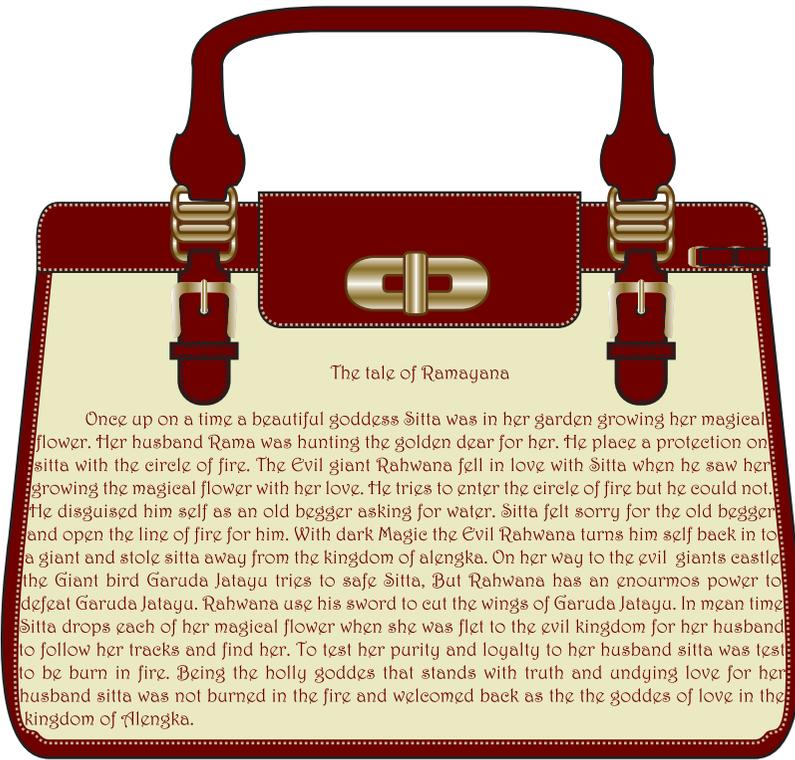

Reversible back view



Reversible side view



Reversible Inside view

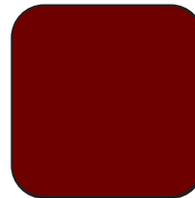
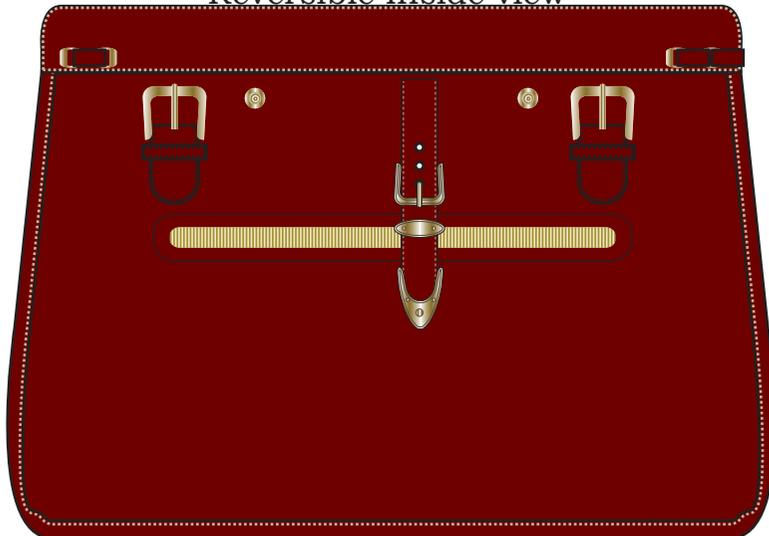

Genuine Leather  
Maroon

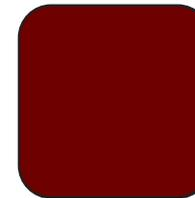

Canvass  
100% cotton  
Maroon



Canvass  
100% cotton  
Creeme

Ramayana



Main front view



Main back view



Main inside view



Main side view



Buckle conector

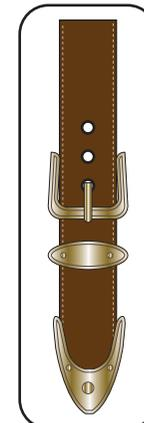

Tassle

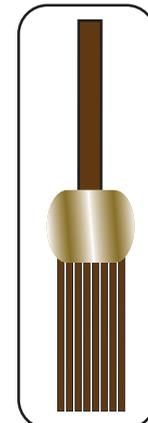

Reversible front view



Reversible back view



Reversible side view



Reversible Inside view

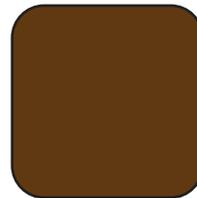
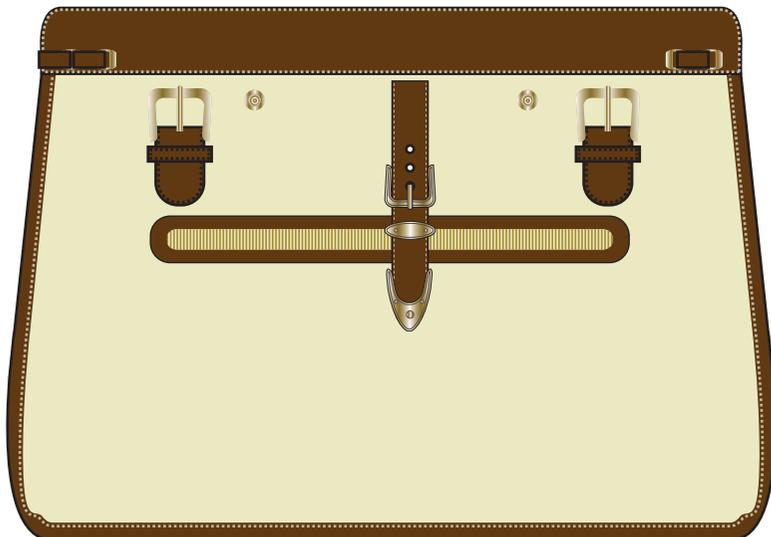

Genuine Leather  
Maroon



Canvass  
100% cotton  
Creeme

# Purasuci

Main front view



Main back view

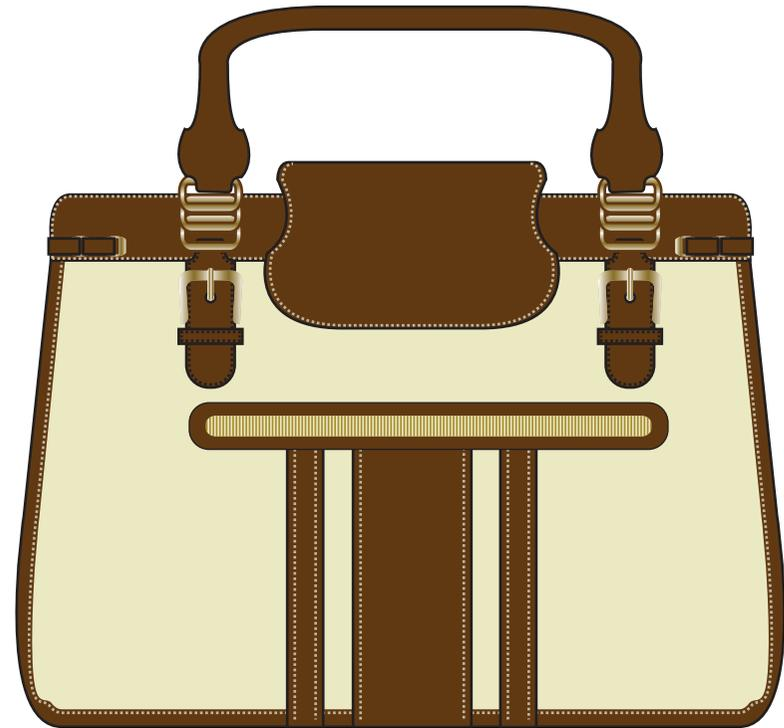

Main inside view



Main side view



Buckle conector

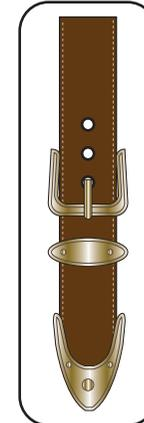

Tassle

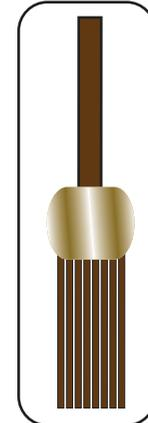

Reversible front view



Reversible back view



Reversible side view



Reversible Inside view

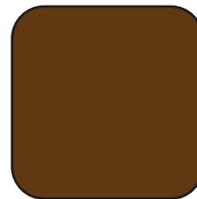
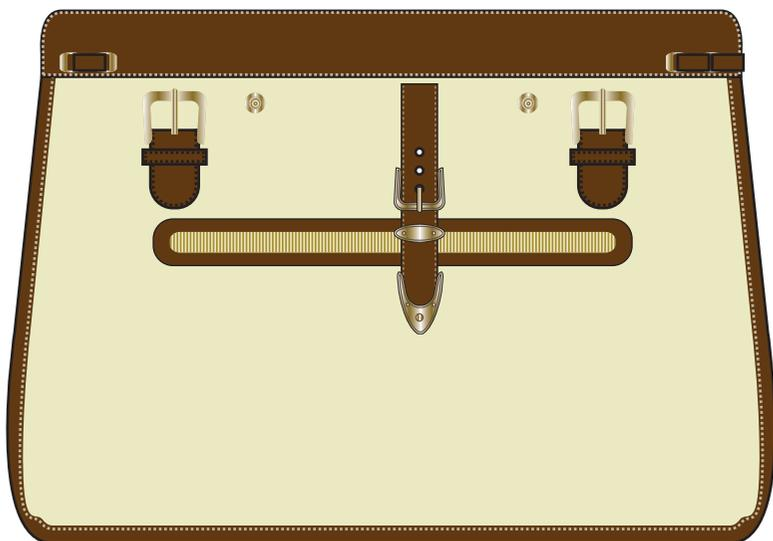

Genuine Leather  
Maroon



Canvass  
100% cotton  
Creeme

# Sesajen

Main front view

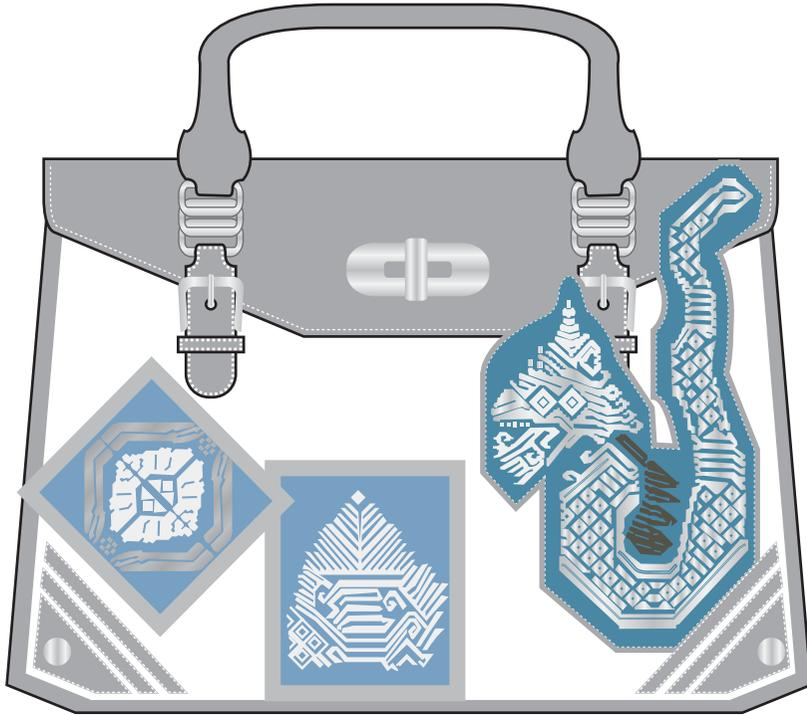

Main back view

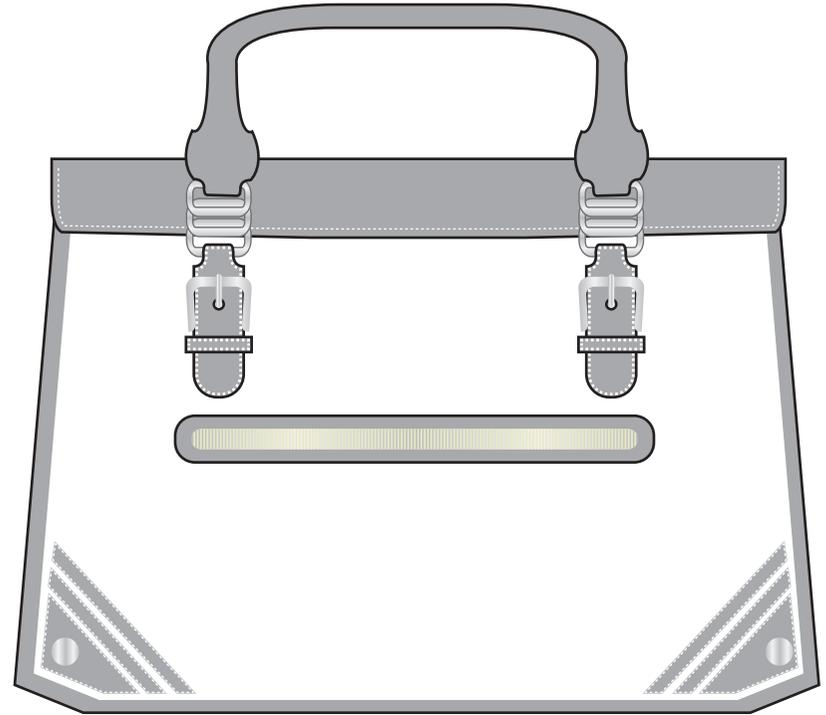

Mai inside view

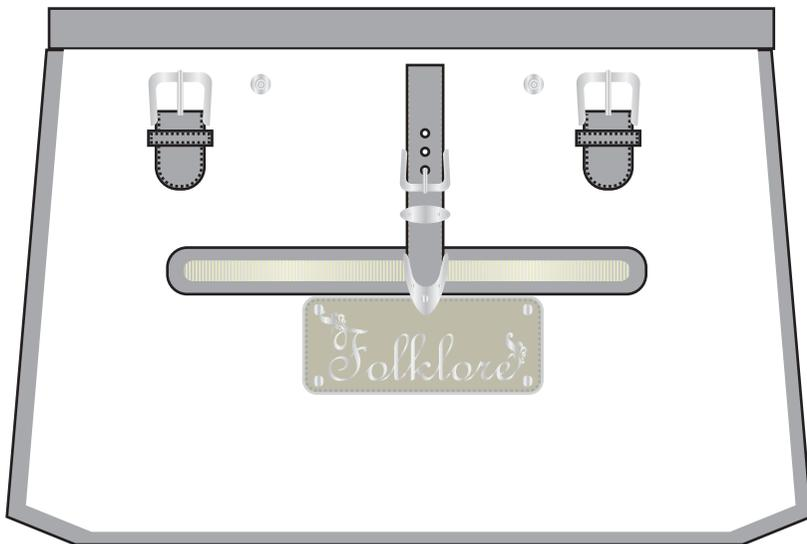

Main side view

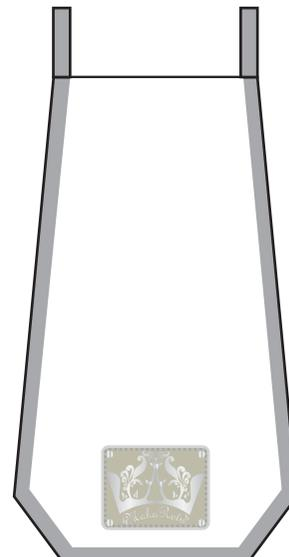

Buckle conector

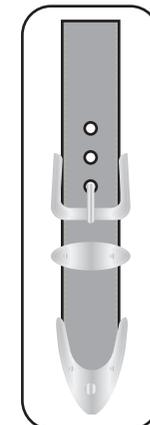

Reversible front view

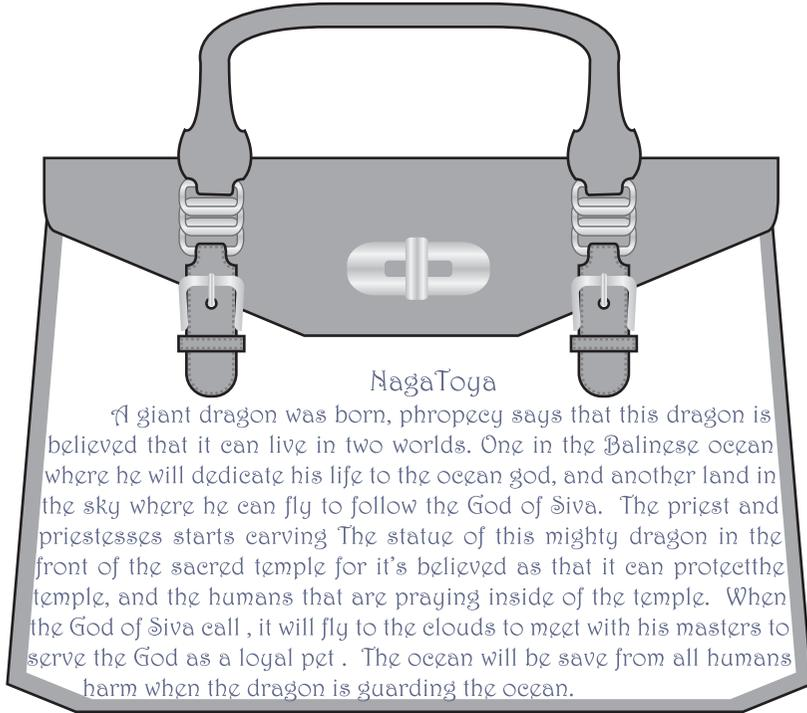

Reversible side view

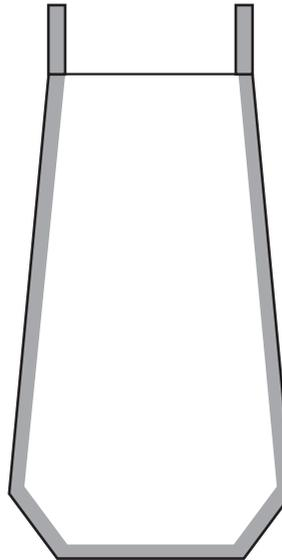

Reversible back view



Reversible Inside view

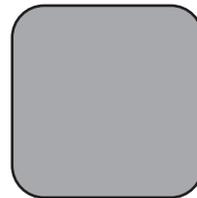
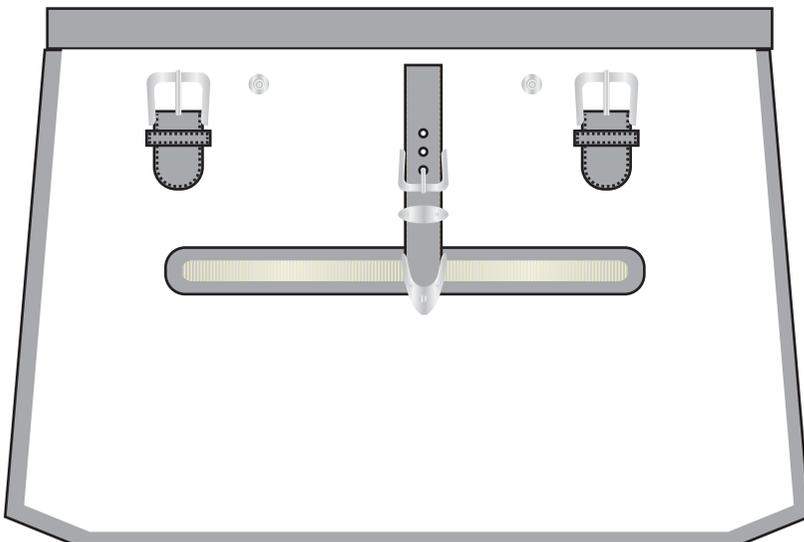

Genuine Leather  
Light Grey



Canvass  
100% cotton  
White

# Naga toya

Main front view



Main back view

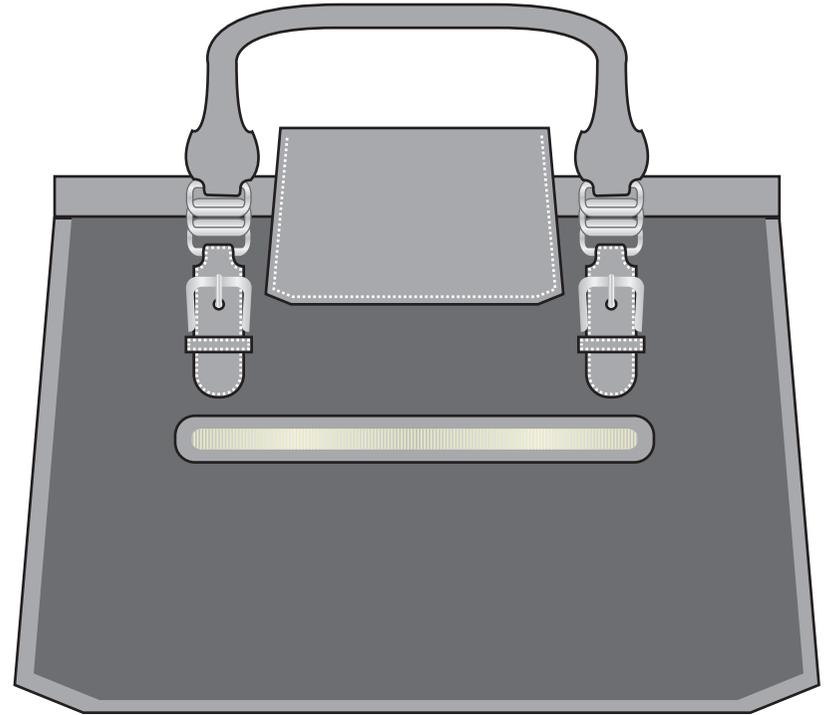

Mai inside view

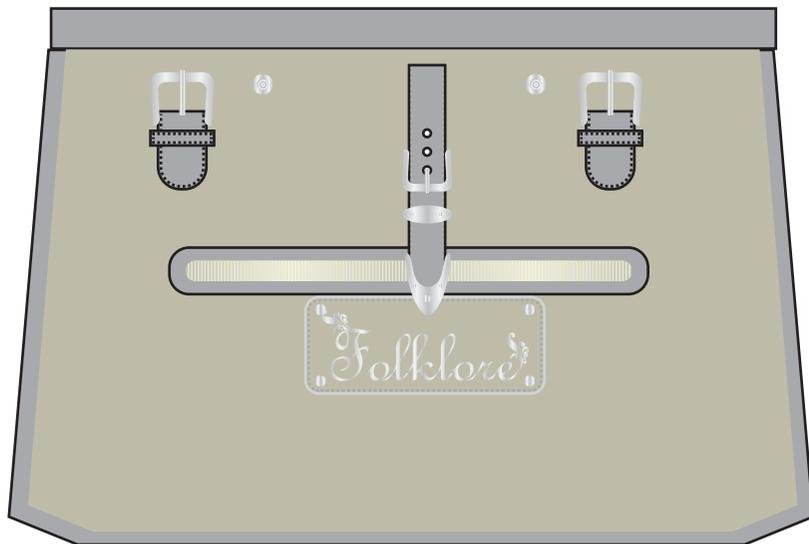

Main side view

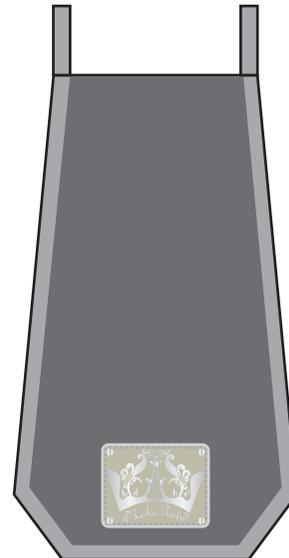

Buckle conector



Reversible front view

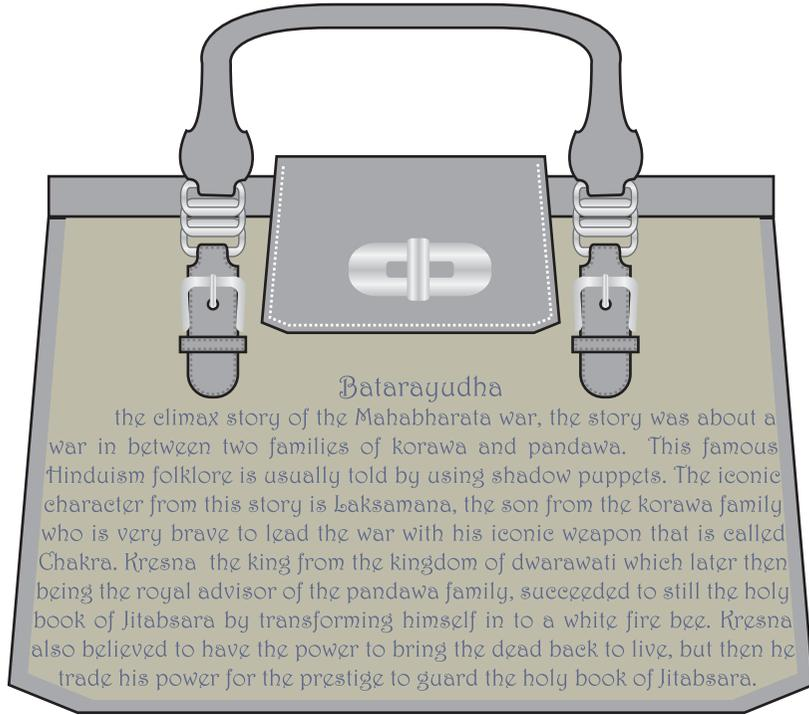

Reversible side view

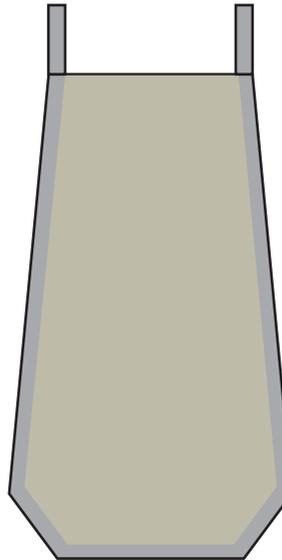

Reversible back view



Reversible Inside view

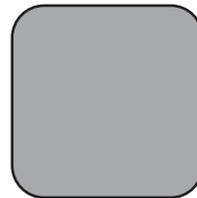
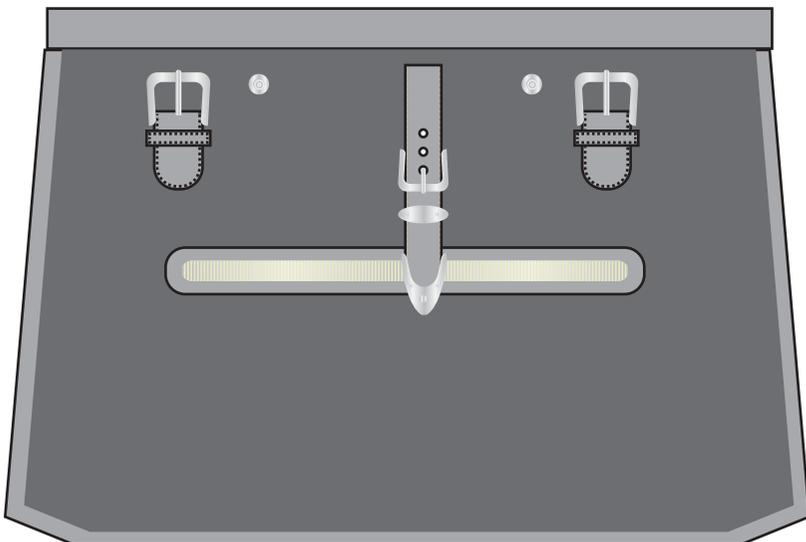

Genuine Leather  
Light Grey



Canvass  
100% cotton  
Warm grey



Canvass  
100% cotton  
grey

Barata yuda



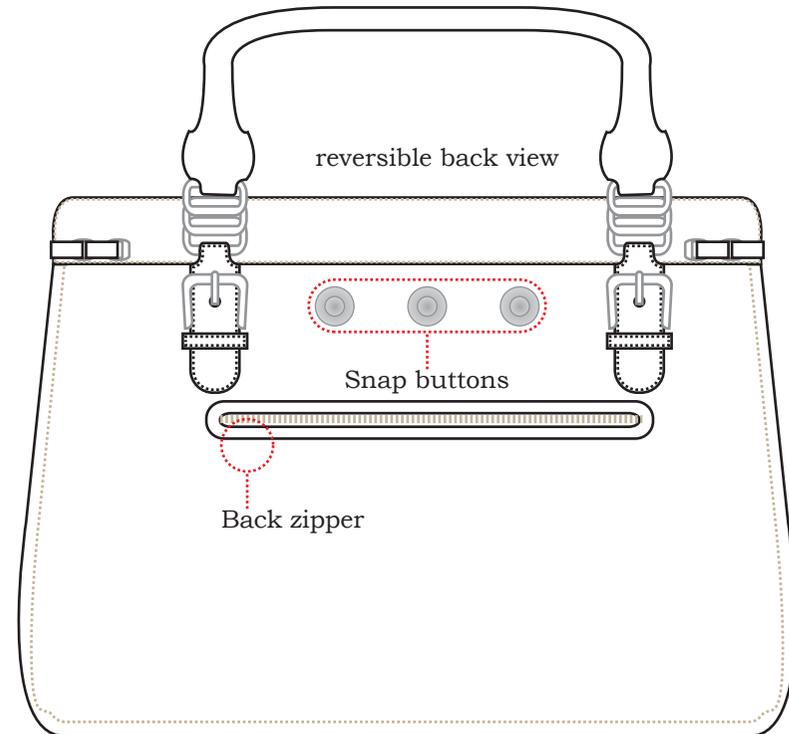
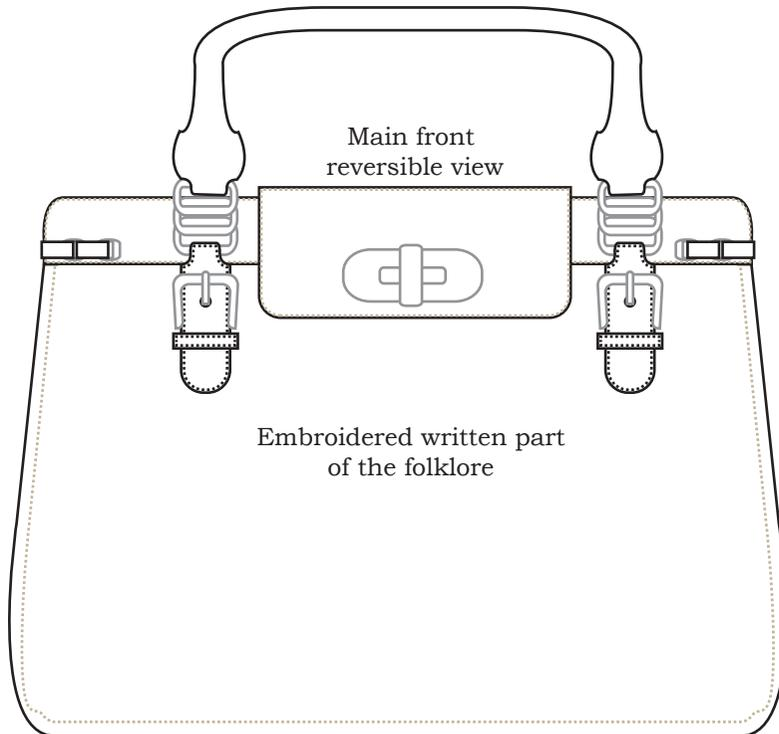
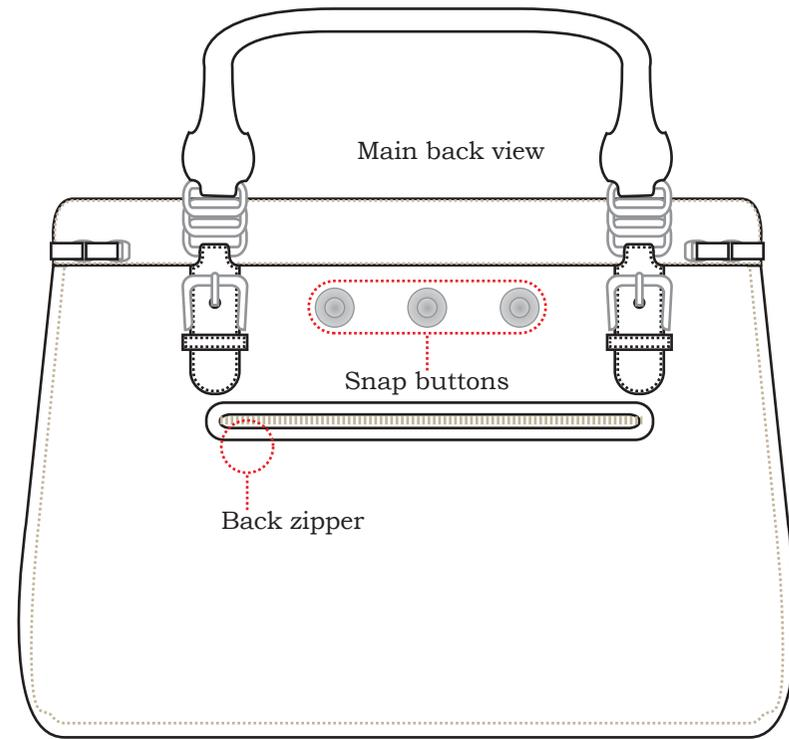
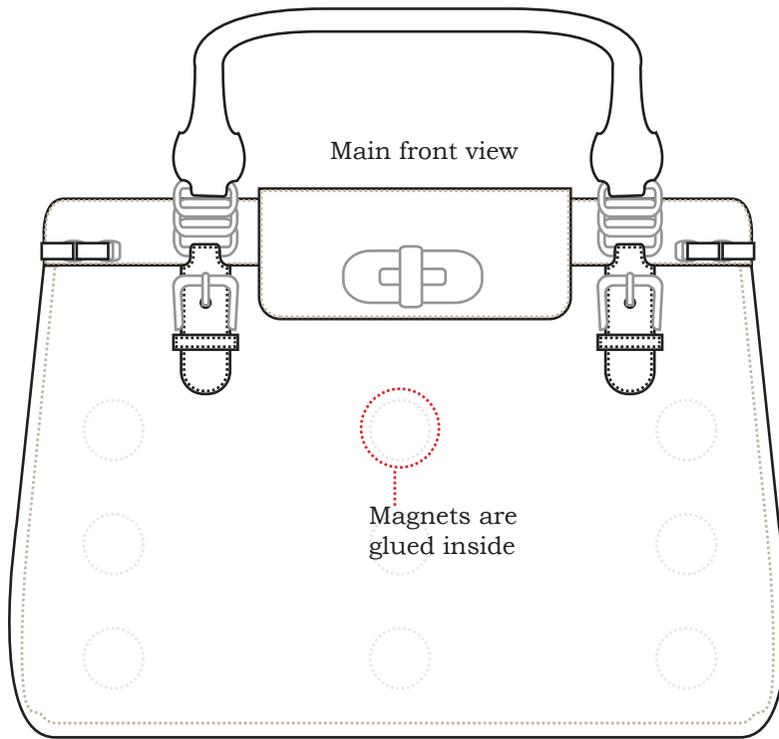

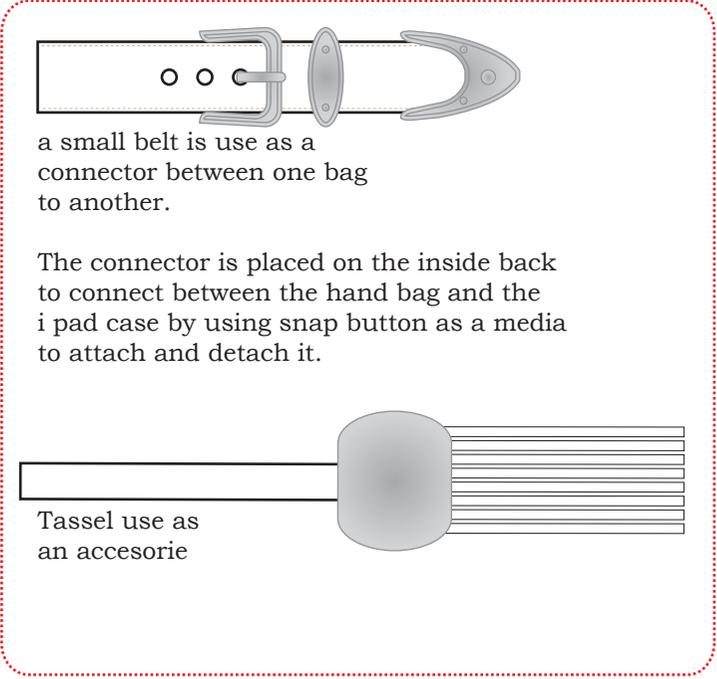
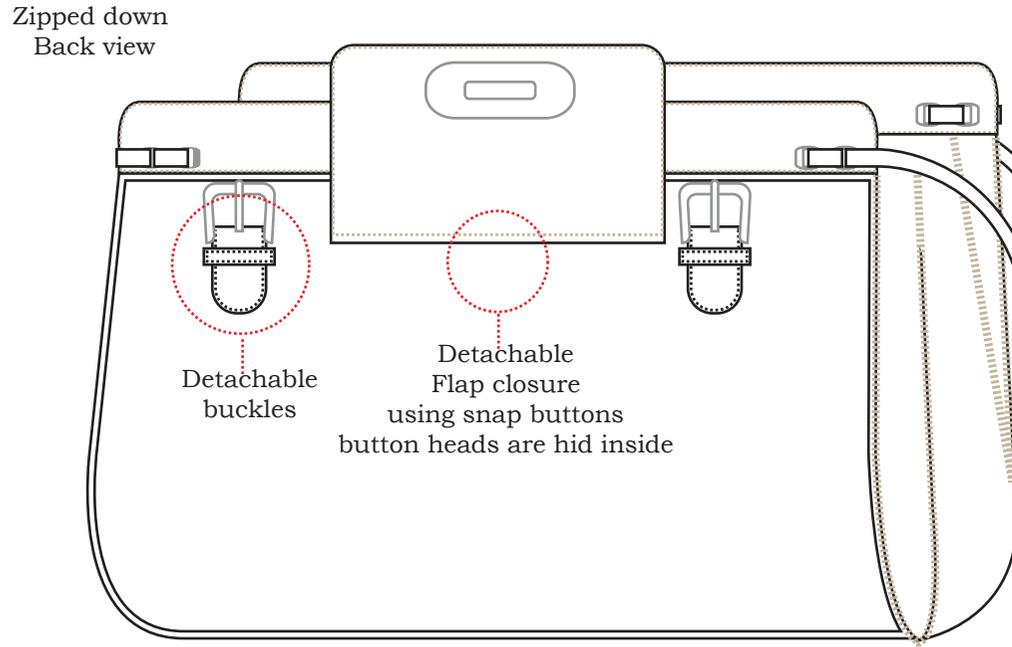
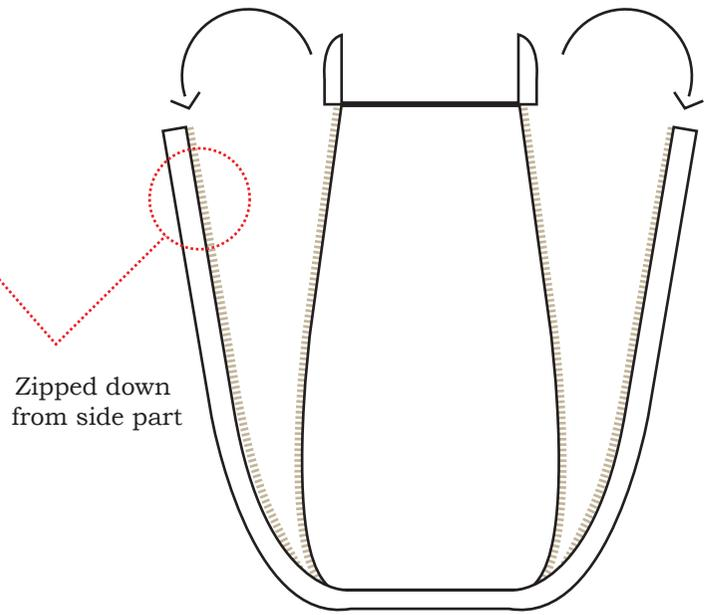
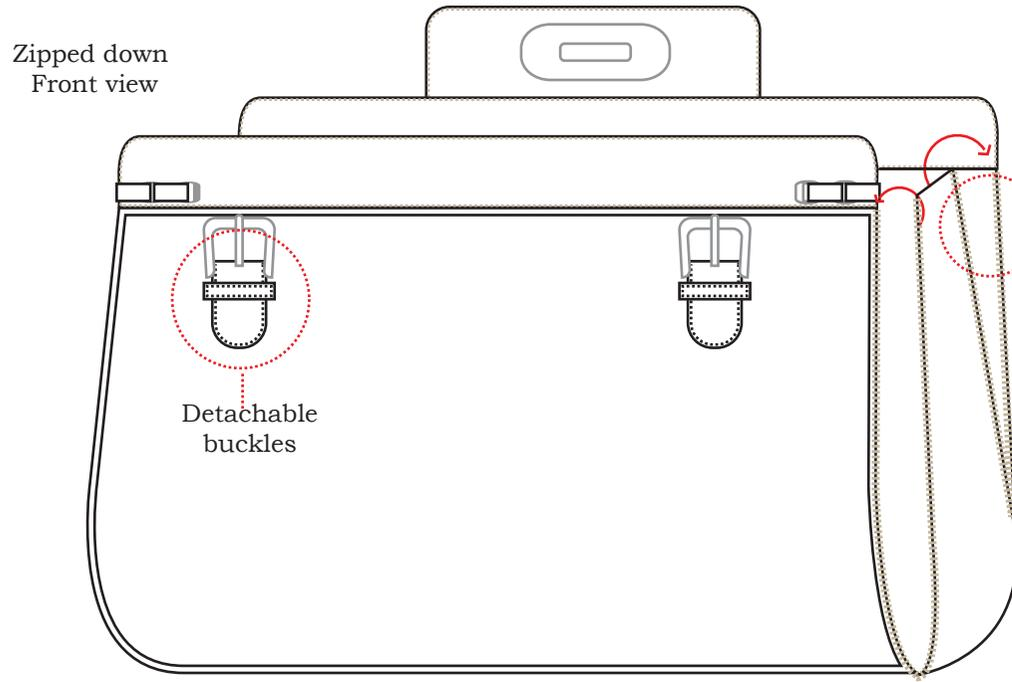

Inside view of the bag  
after being flatt opened

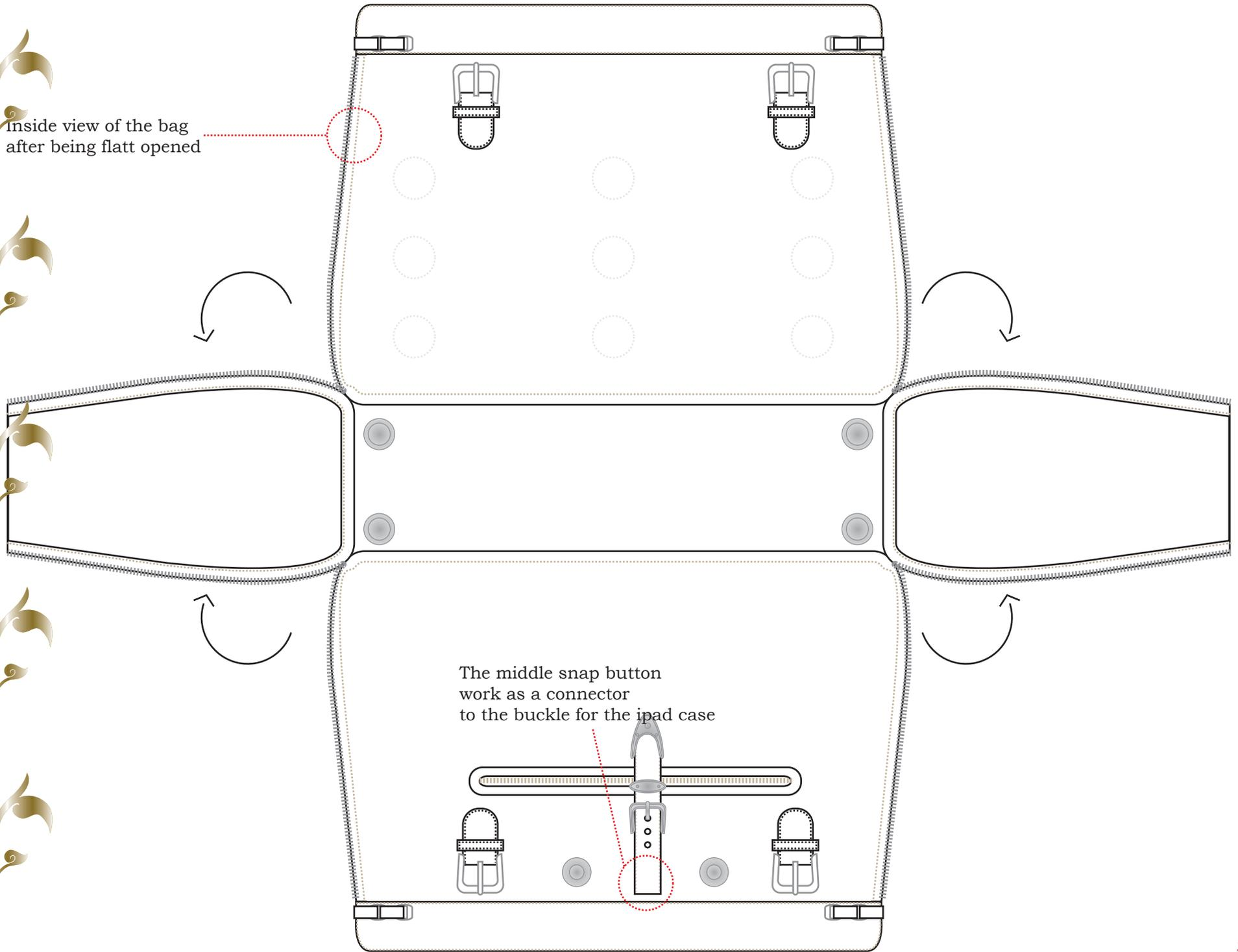

# Main body Size

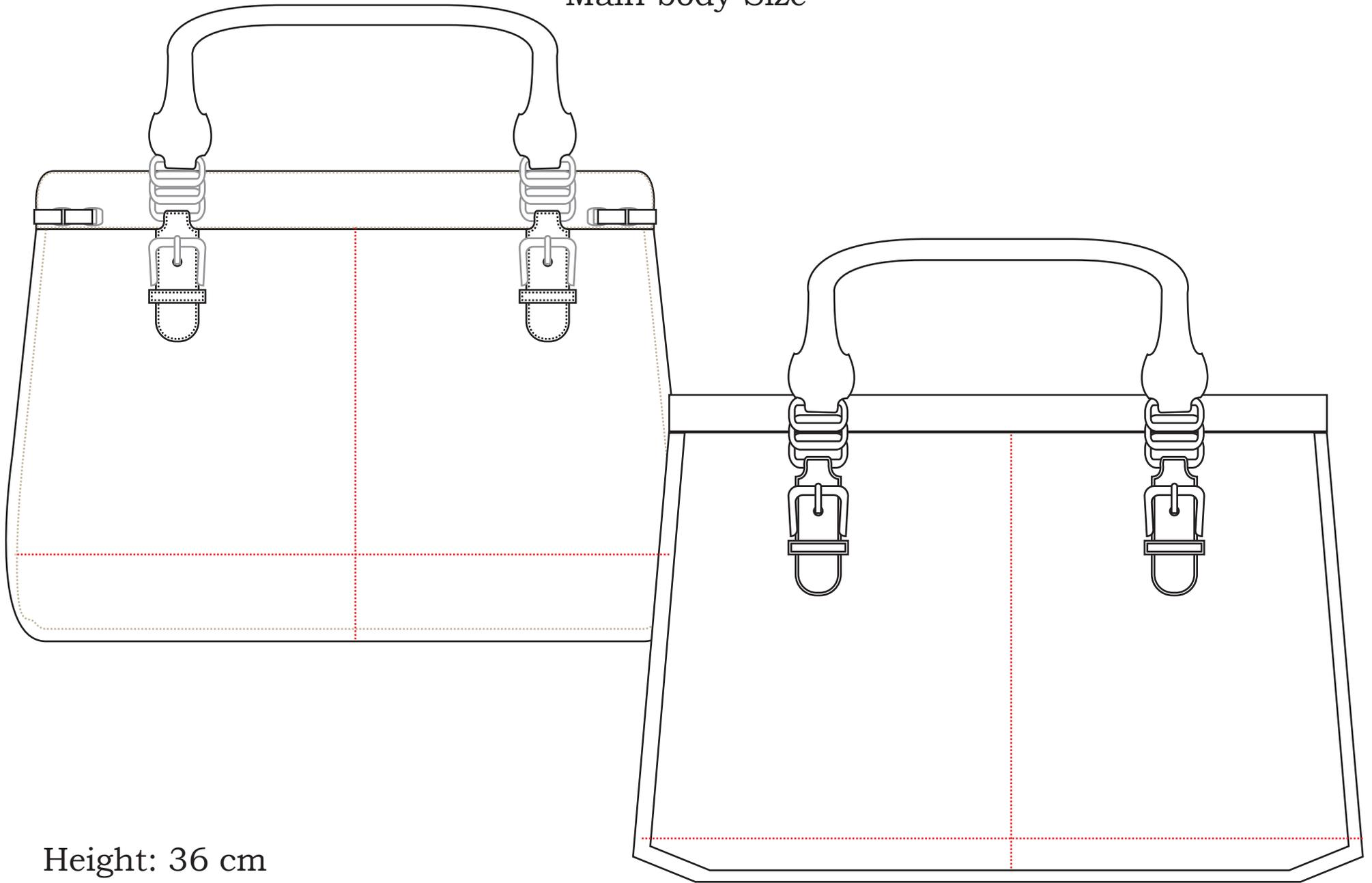

Height: 36 cm

Width: 29 cm

Depth: 14cm

# Flap detail sizes

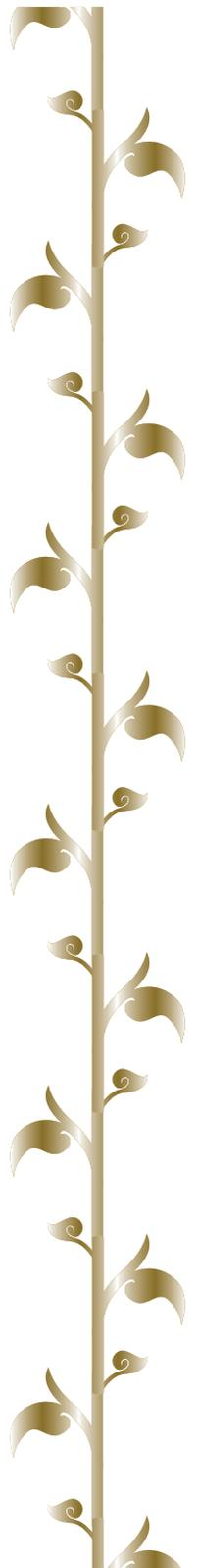
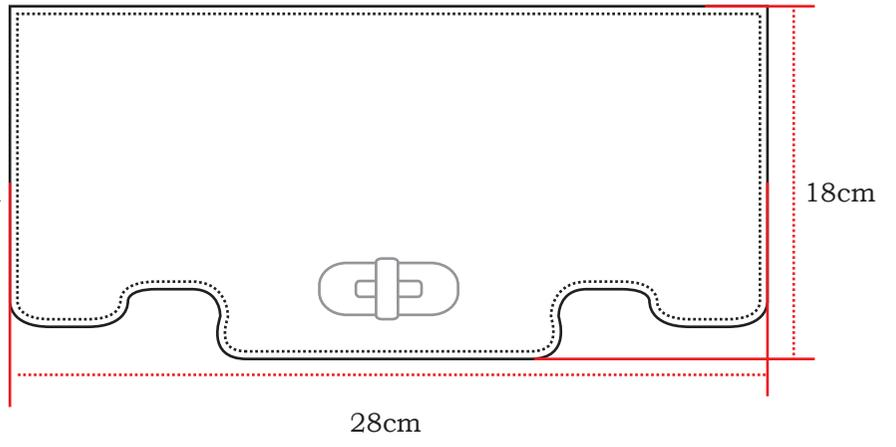
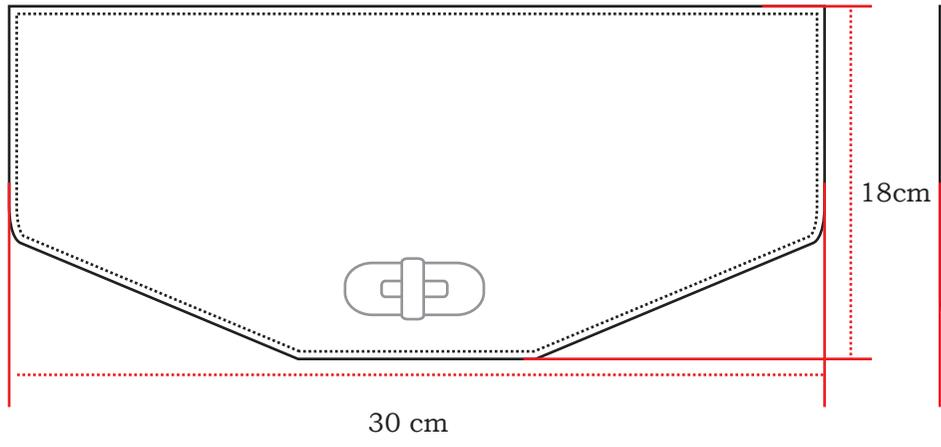
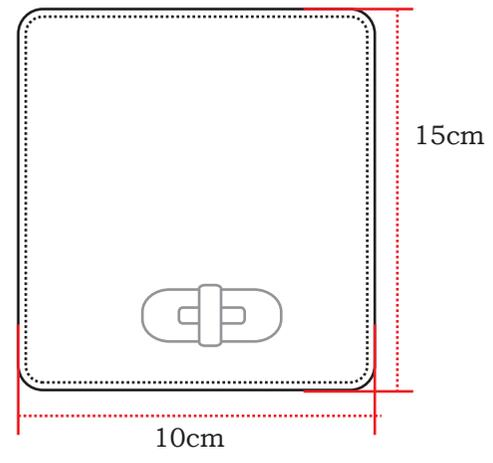
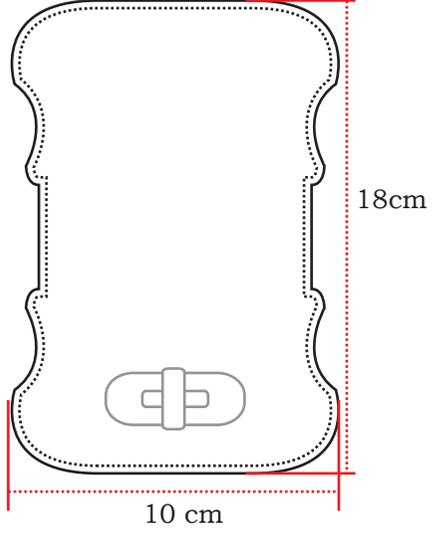
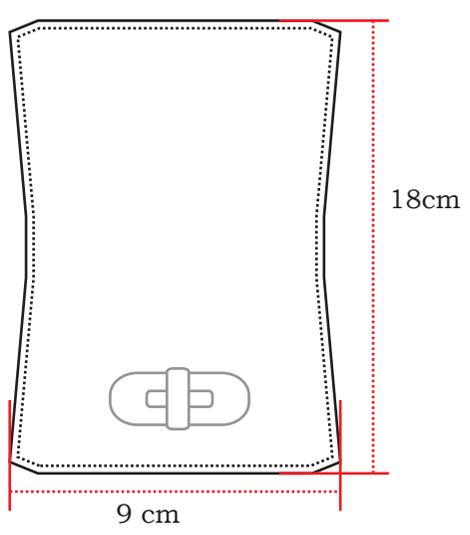



Main front view



Reversible front view

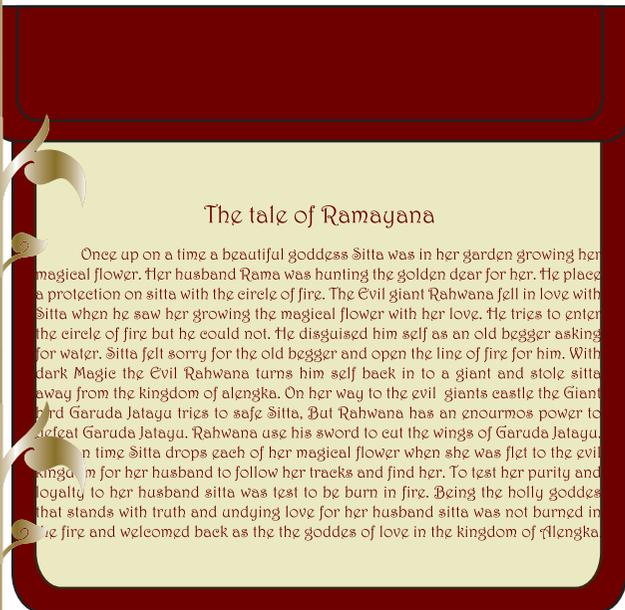

Main back view



side view



Inside main view



Genuine leather  
Maroon

Canvass  
100% Cotton  
Maroon

Canvass  
100% Cotton  
Creme

# Ramayana

Main front view



Main back view



Genuine leather  
Brown



Canvass  
100% Cotton  
Creme

Reversible  
front view

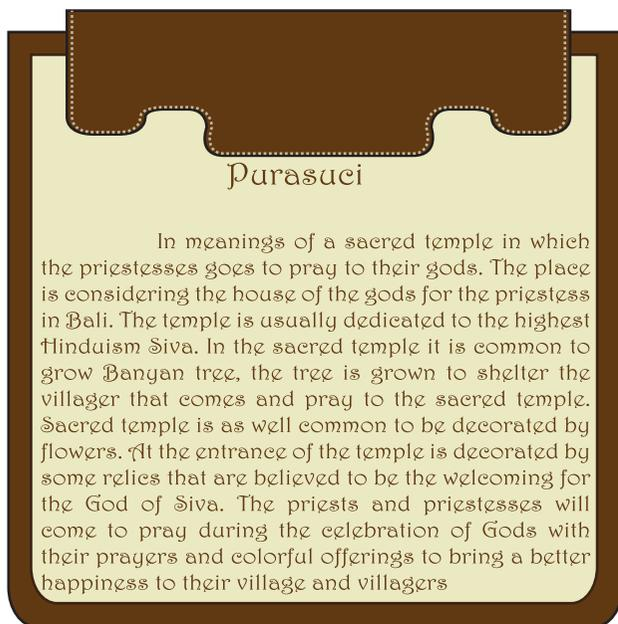

side view



Inside main view



# Purasuci



Main front view

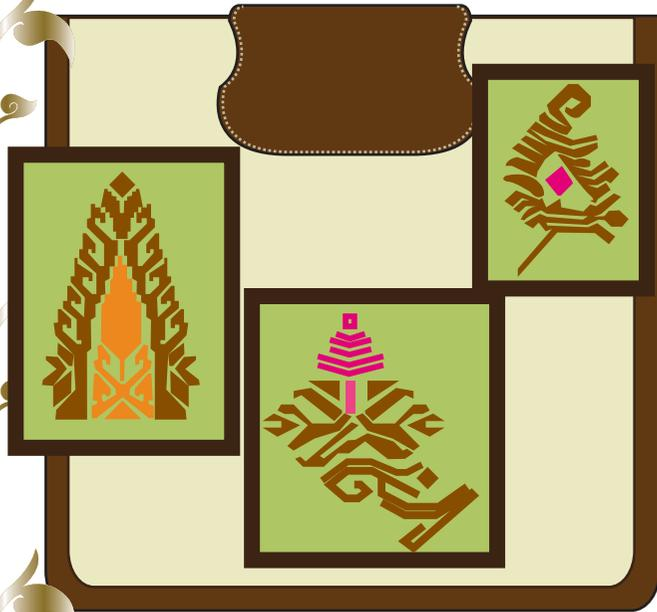

Main back view

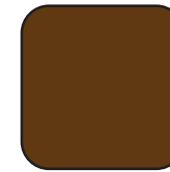

Genuine leather  
Brown



Canvass  
100% Cotton  
Creme

Reversible front view

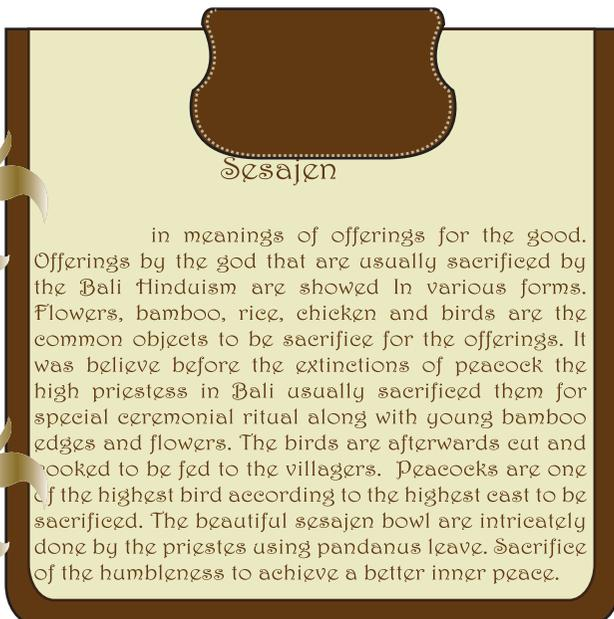

side view



Inside main view



# Sesajen

Main front view

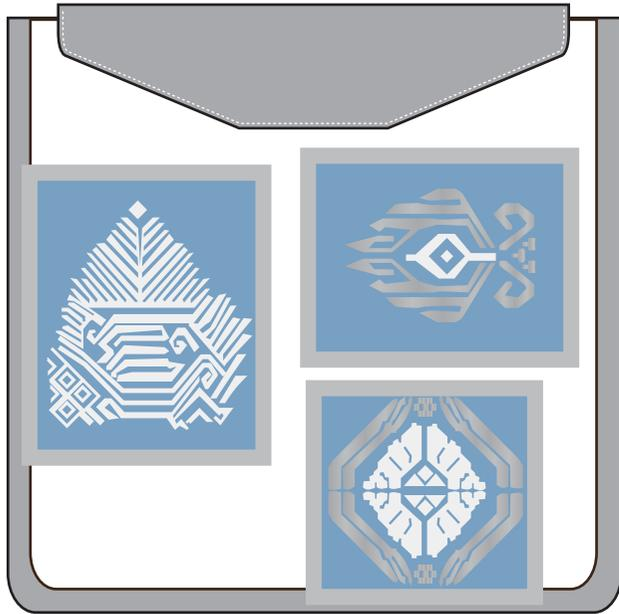

Main back view

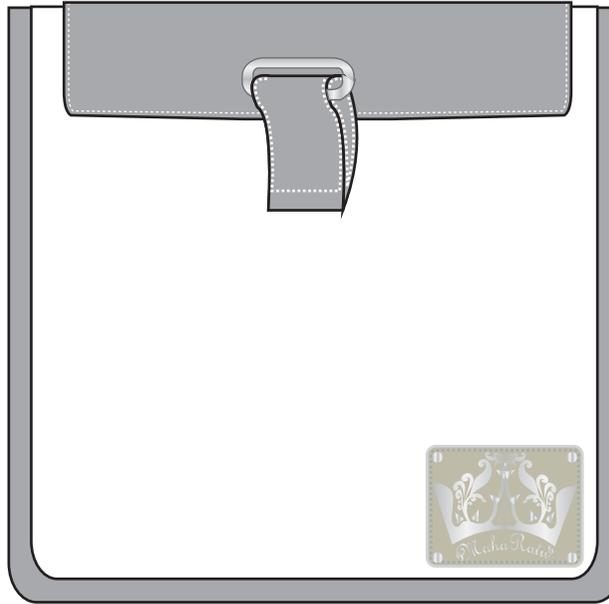

Canvass  
100% Cotton  
White

Genuine leather  
Grey

Reversible front view

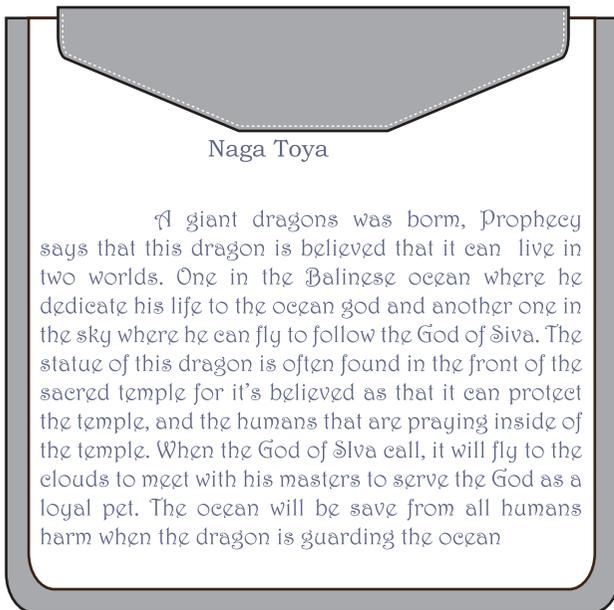

side view

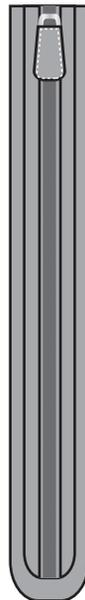

Inside main view



Naga Toya

Main front view



Main back view

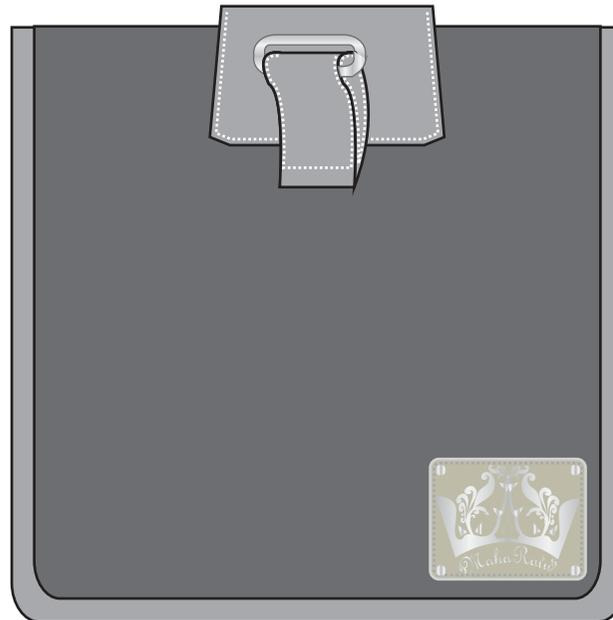

Genuine leather  
Light grey

Canvass  
100% Cotton  
Warm grey

Canvass  
100% Cotton  
Grey

Reversible front view

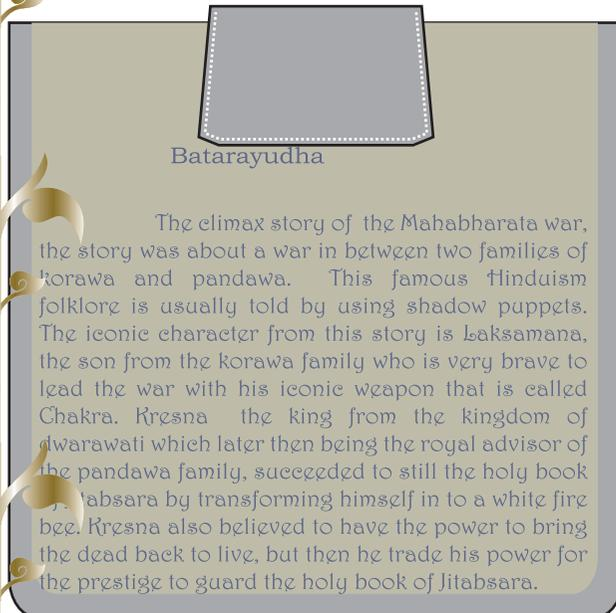

side view

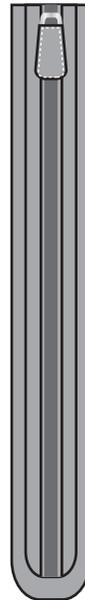

Inside main view

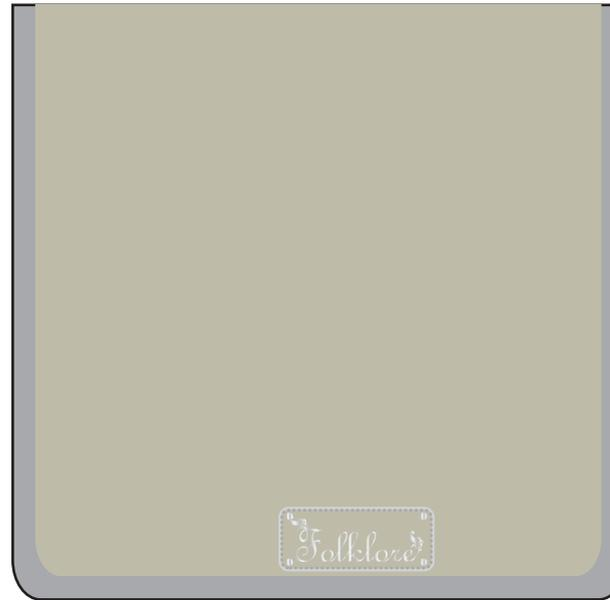

# Batarayudha





Main front view

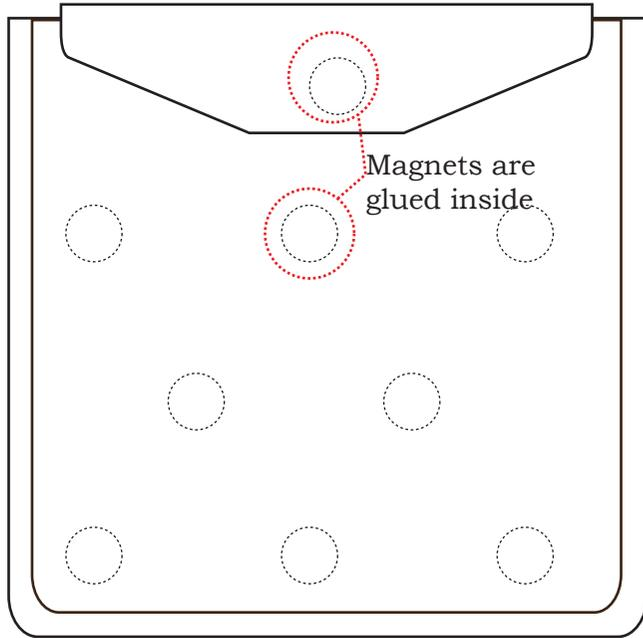

back view

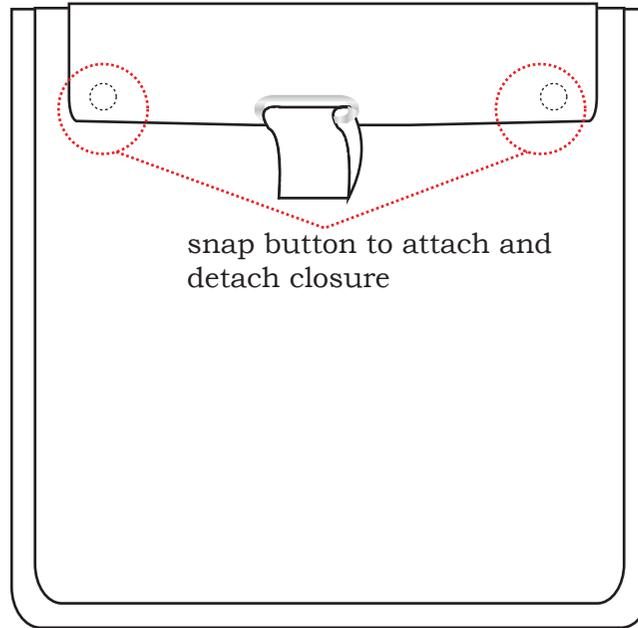

side view

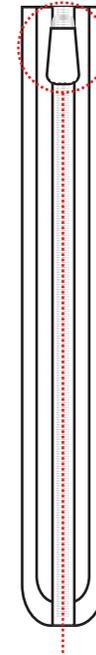

Reversible front view

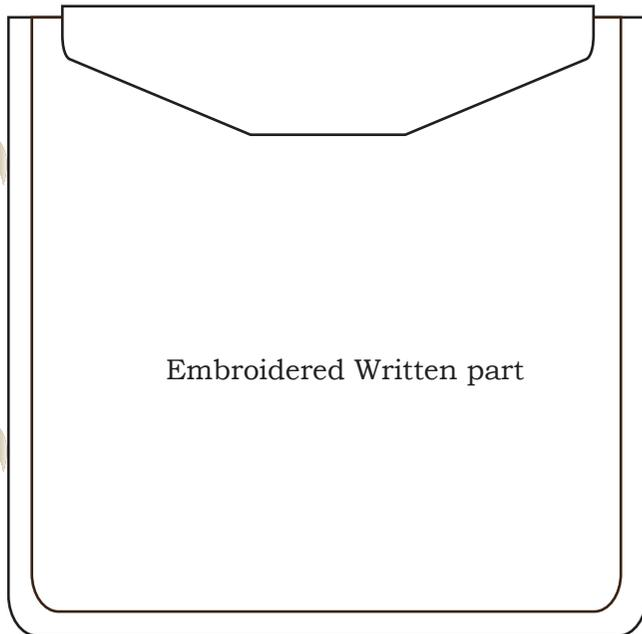

Inside view

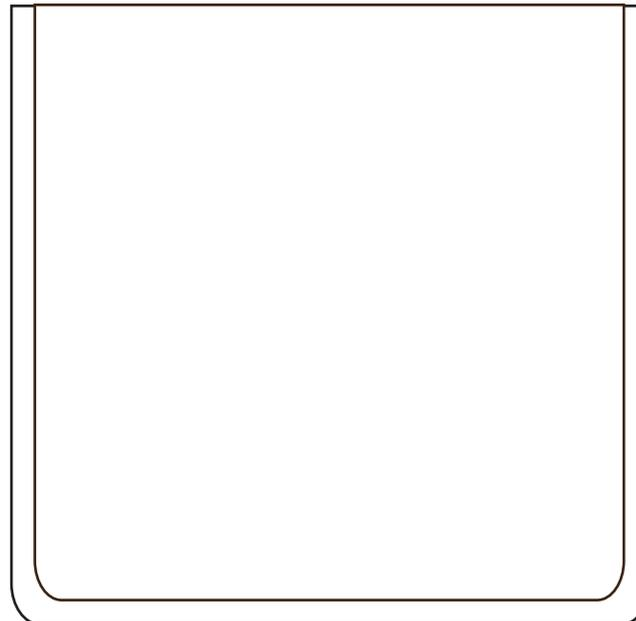

Zipped out

Flatt open view

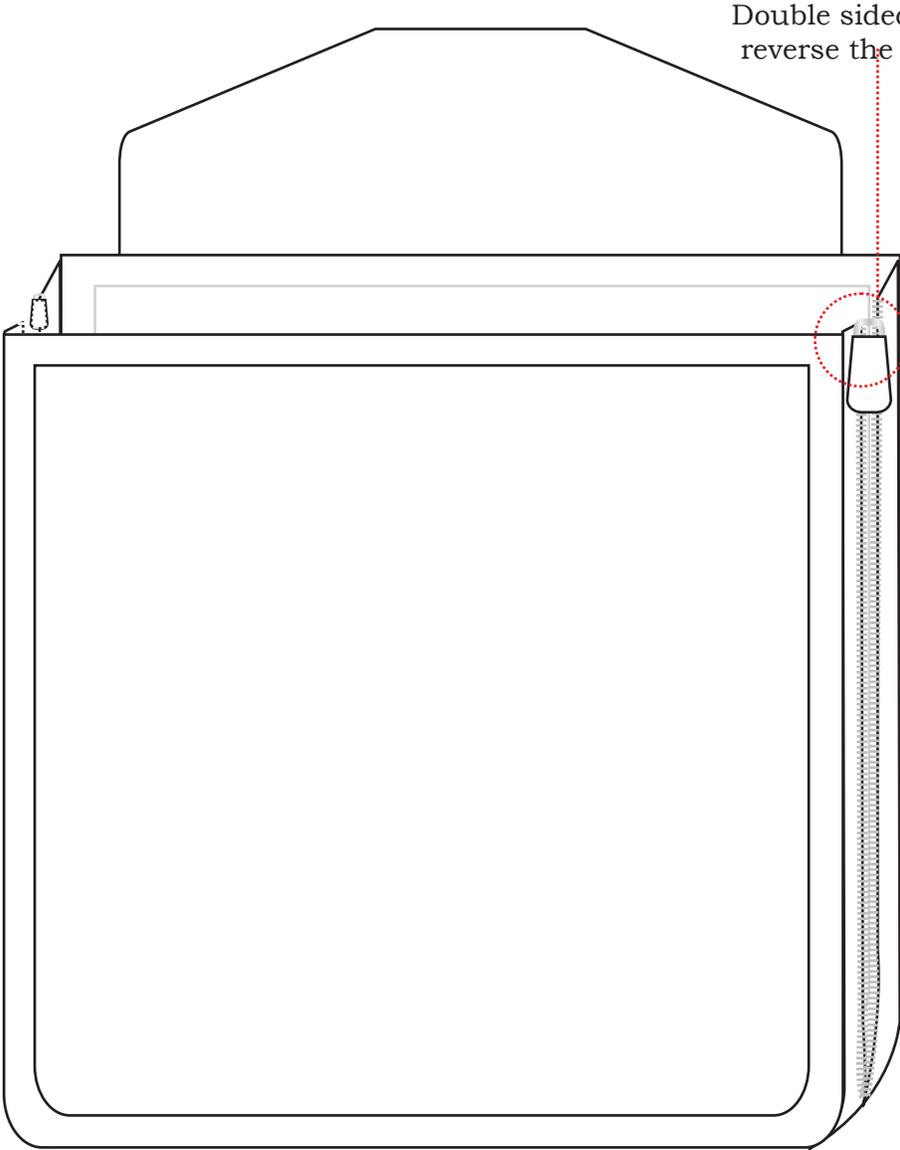

Double sided zipper to open and reverse the i pad case

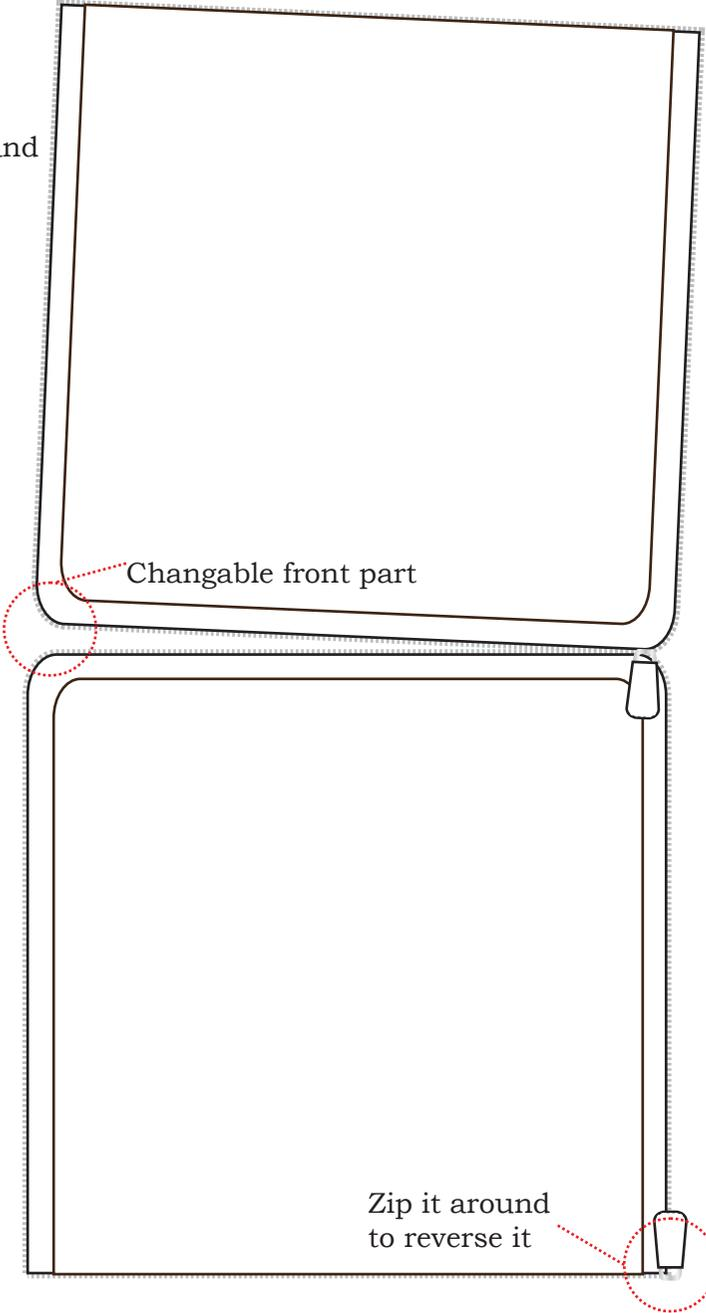

Changable front part

Zip it around to reverse it

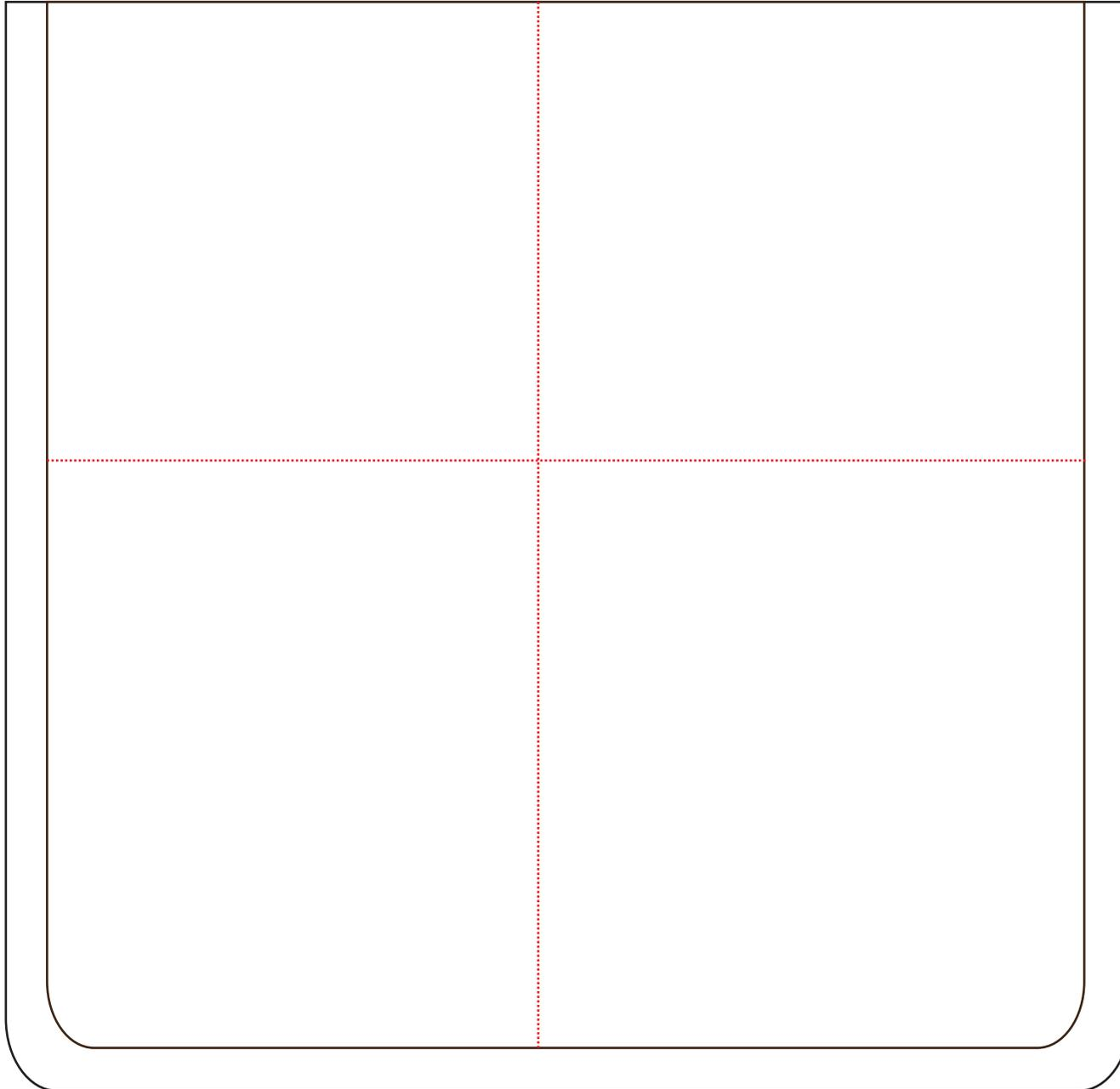

Height: 26 cm  
Widht: 25 cm  
Depth: 3 cm

# Flap detail sizes

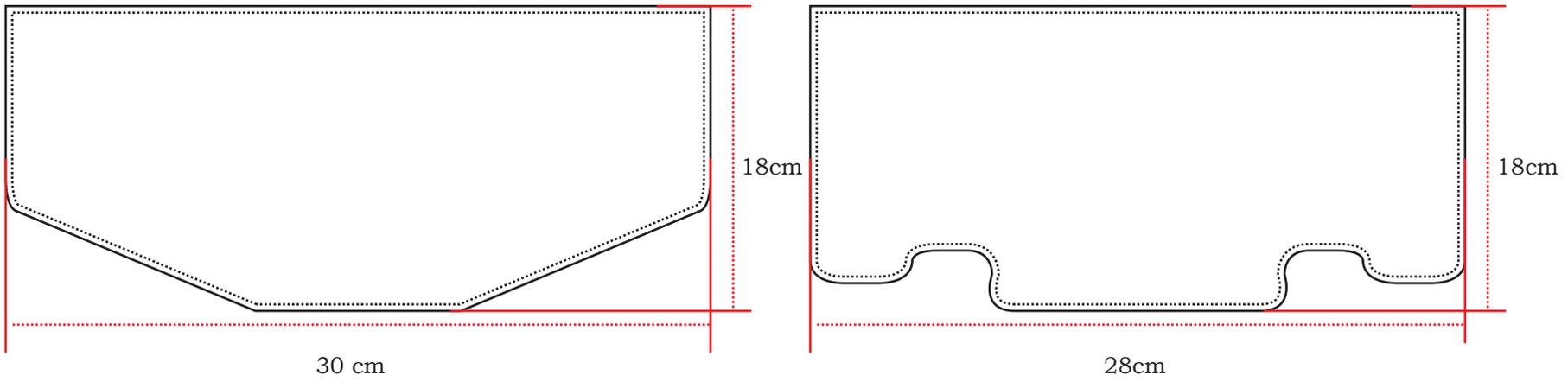
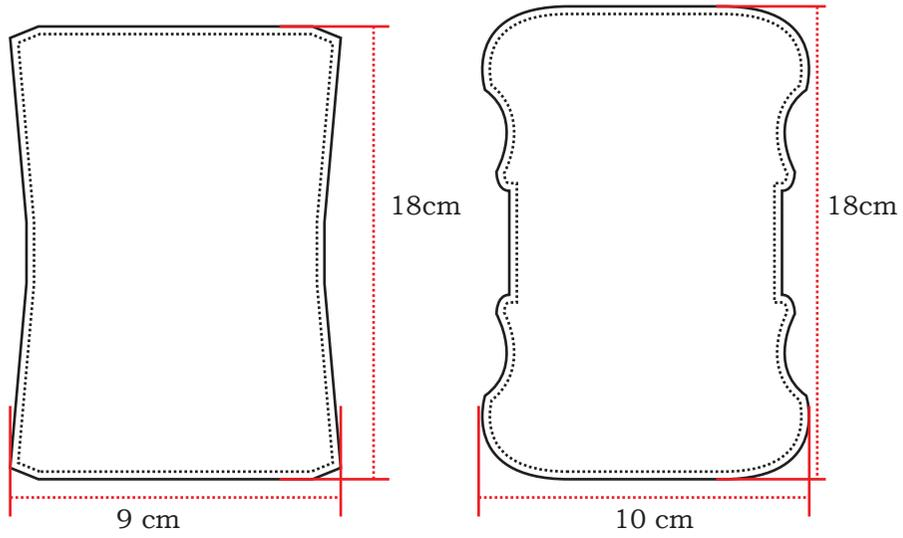



Front View



Back View

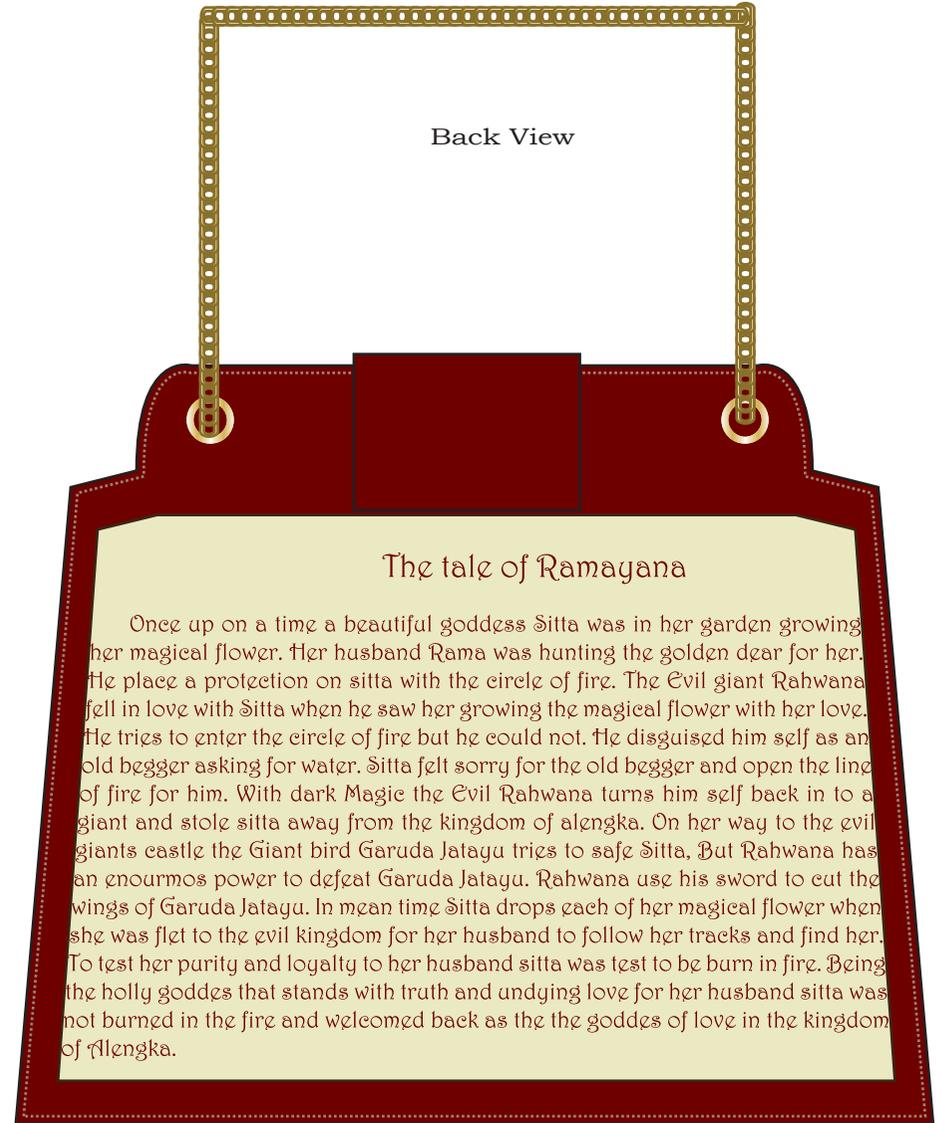

Genuine leather  
Maroon



Canvass  
100% Cotton  
Maroon



Canvass  
100% Cotton  
Creme

# Ramayana

Front View



Back View

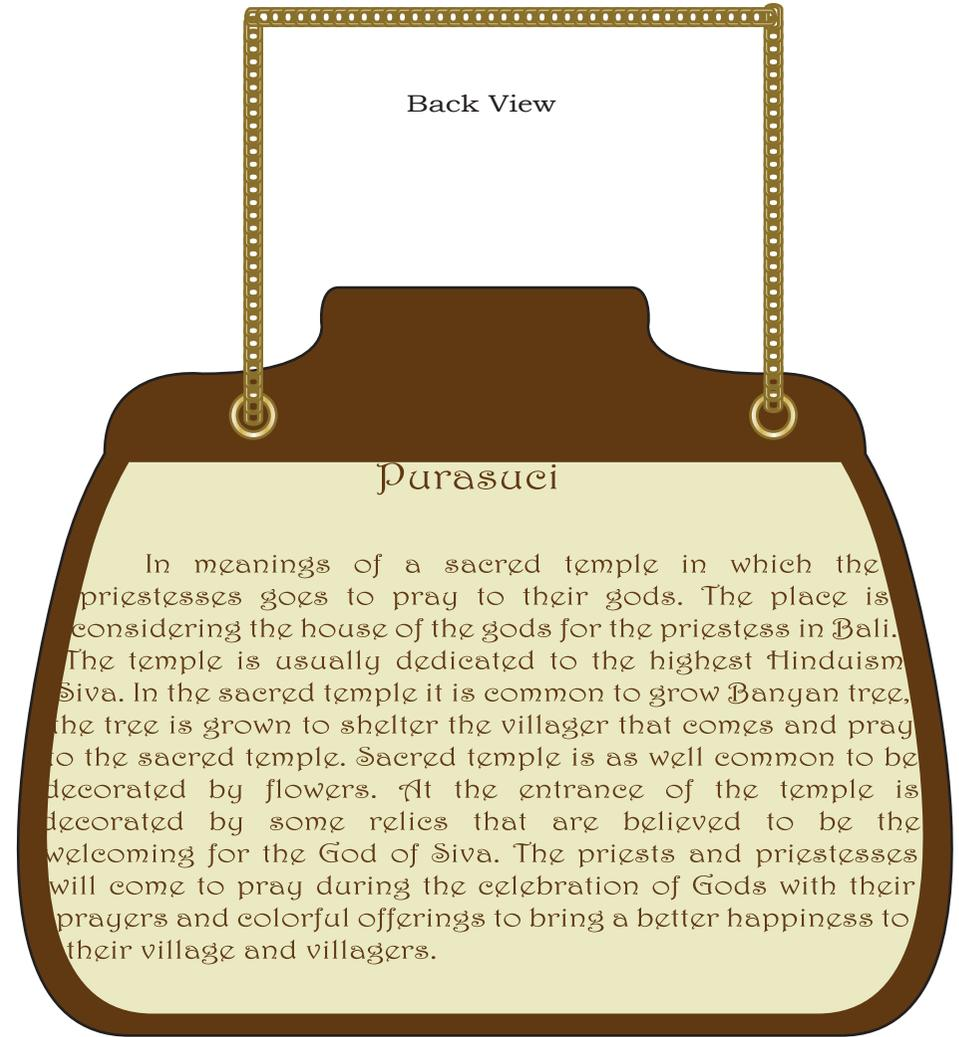

### Purasuci

In meanings of a sacred temple in which the priestesses goes to pray to their gods. The place is considering the house of the gods for the priestess in Bali. The temple is usually dedicated to the highest Hinduism Siva. In the sacred temple it is common to grow Banyan tree, the tree is grown to shelter the villager that comes and pray to the sacred temple. Sacred temple is as well common to be decorated by flowers. At the entrance of the temple is decorated by some relies that are believed to be the welcoming for the God of Siva. The priests and priestesses will come to pray during the celebration of Gods with their prayers and colorful offerings to bring a better happiness to their village and villagers.



Genuine leather  
Brown



Canvass  
100% Cotton  
Creme

## Purasuci



Front View



Back View



Genuine leather  
Brown



Canvass  
100% Cotton  
Creme

# Sesajen

offerings for the good. Offerings by the god that are usually sacrificed by the Bali Hinduism are showed in various forms. Flowers, bamboo, rice, chicken and birds are the common objects to be sacrifice for the offerings. It was believe before the extinctions of peacock the high priestess in Bali usually sacrificed them for special ceremonial ritual along with young bamboo edges and flowers. The birds are afterwards cut and cooked to be fed to the villagers. Peacocks are one of the highest bird according to the highest east to be sacrificed. The beautiful sesajen bowl are intricately done by the priestes using pandanus leave. Sacrifice of the humbleness to achieve a better inner peace.

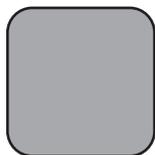
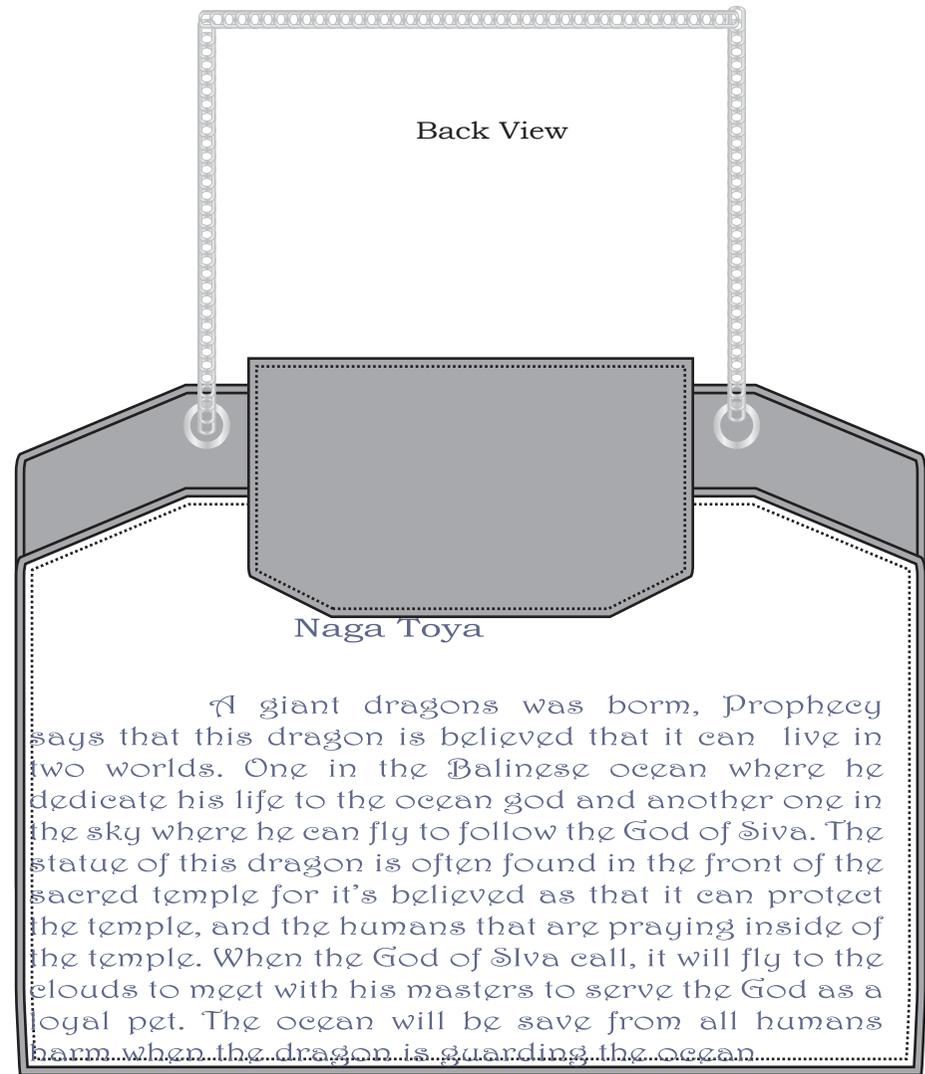
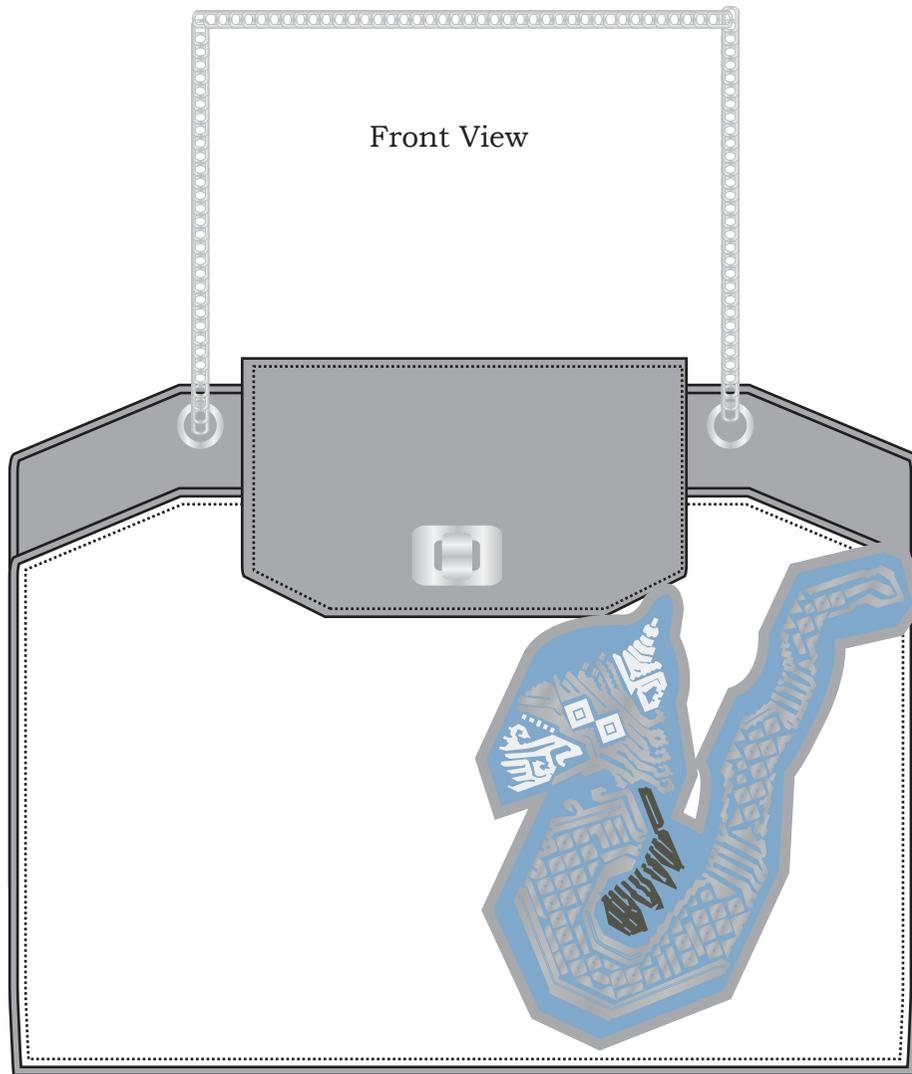

Genuine leather  
Light Grey



Canvass  
100% Cotton  
White

# Nagatoya

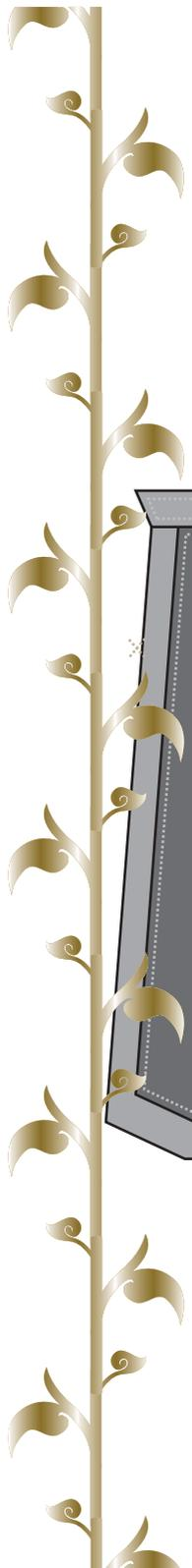

Front View

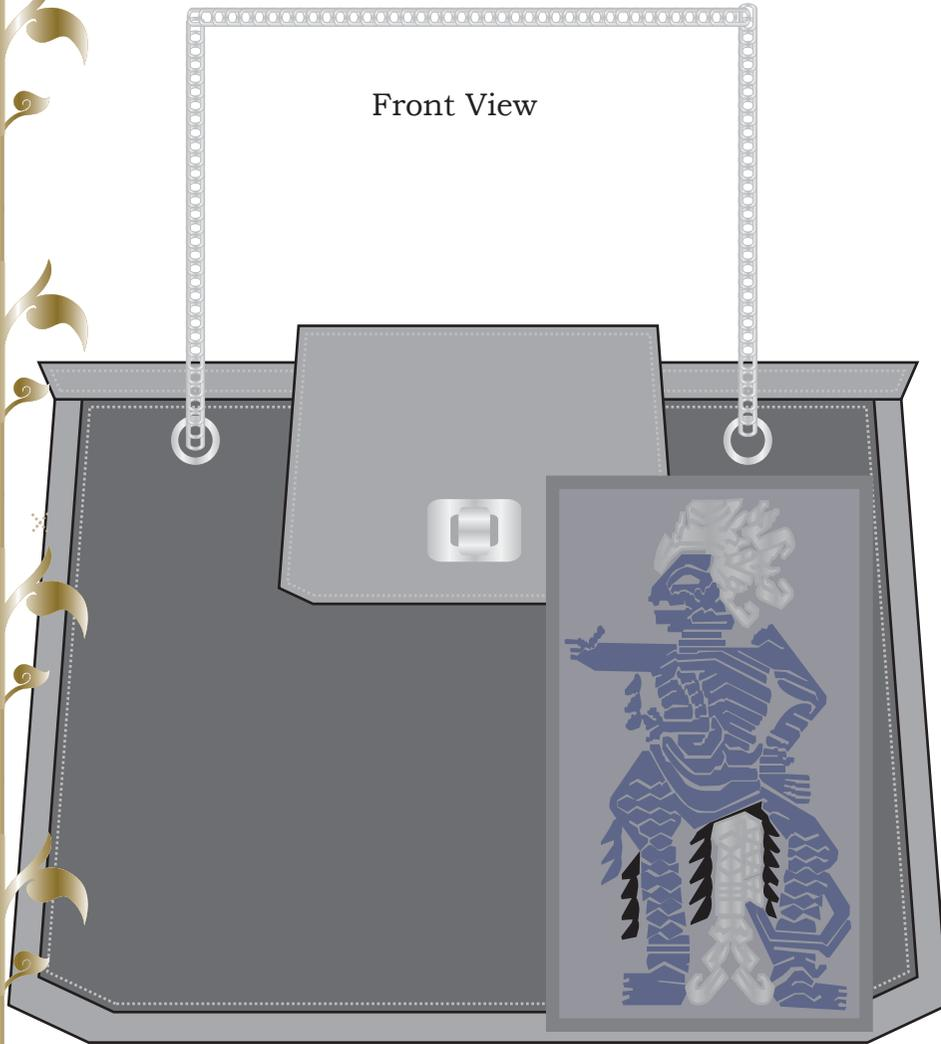

Back View

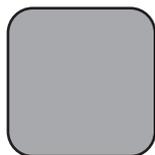
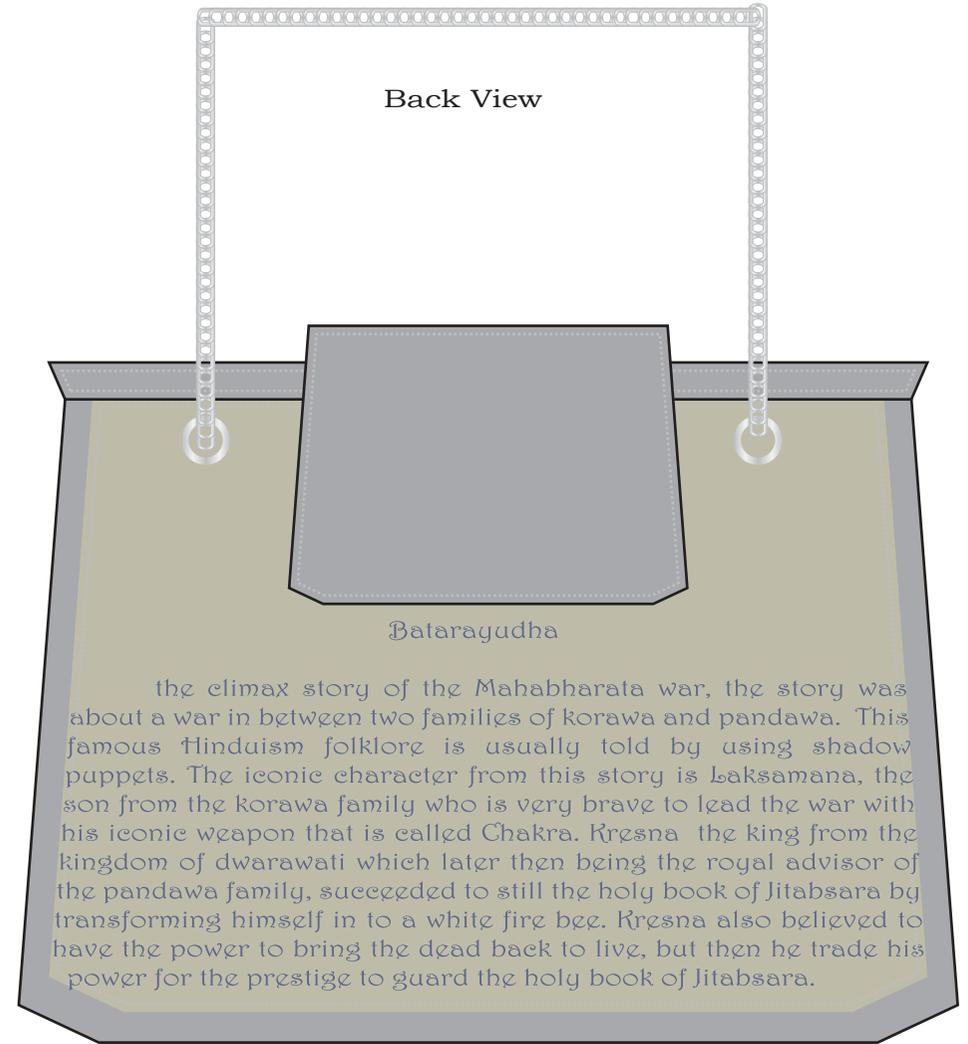

Genuine leather  
Light grey



Canvass  
100% Cotton  
Grey



Canvass  
100% Cotton  
Warm grey

# Batarayudha



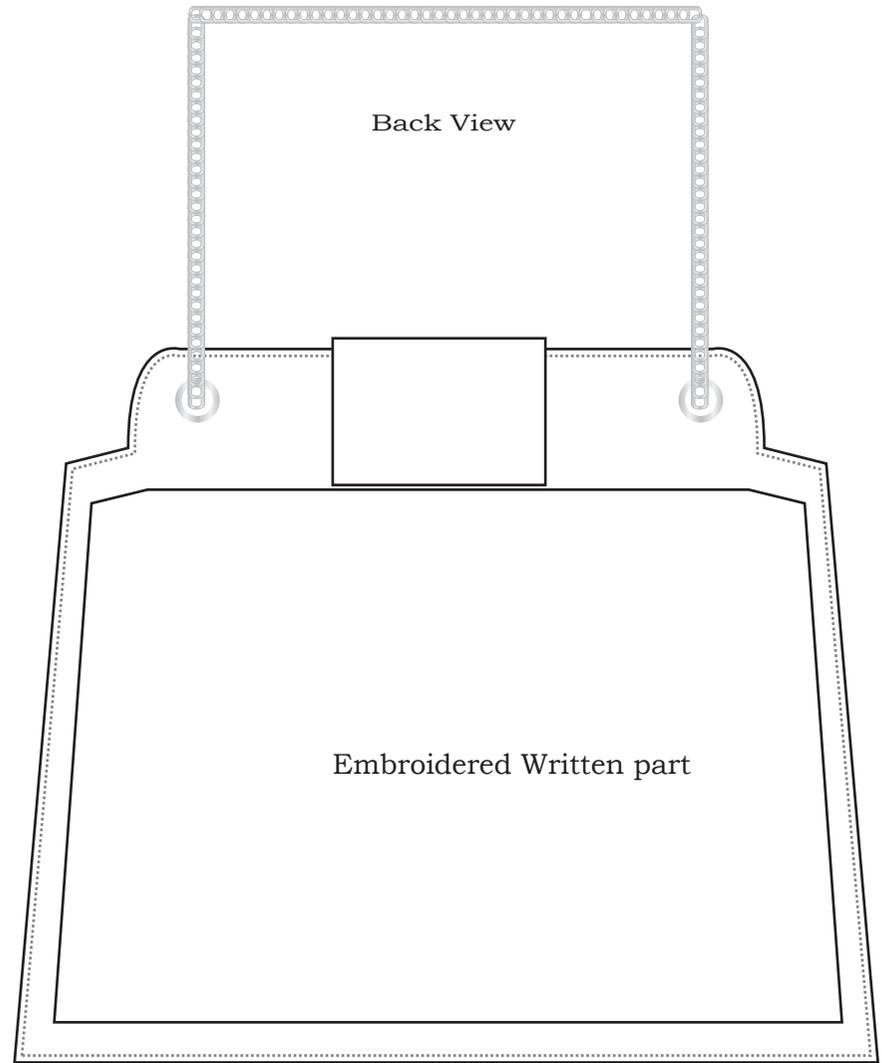
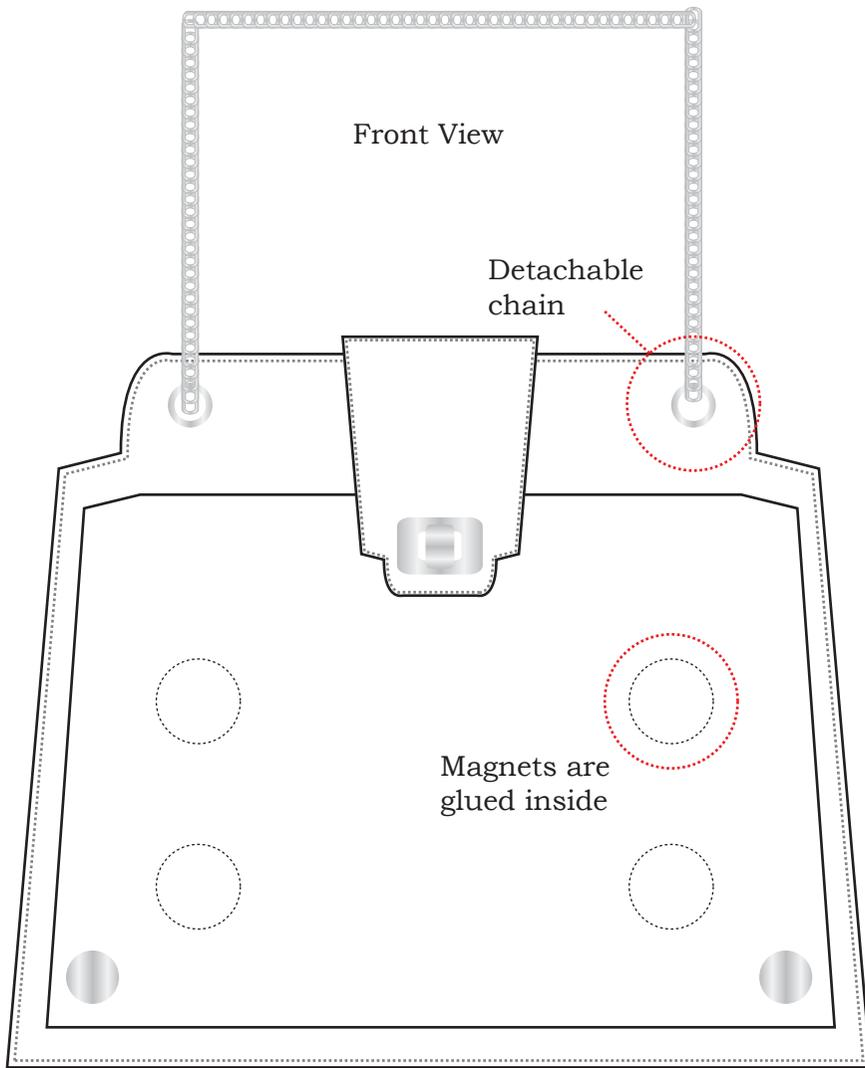

Height: 26 cm  
Widht: 25 cm  
Depth: 3 cm

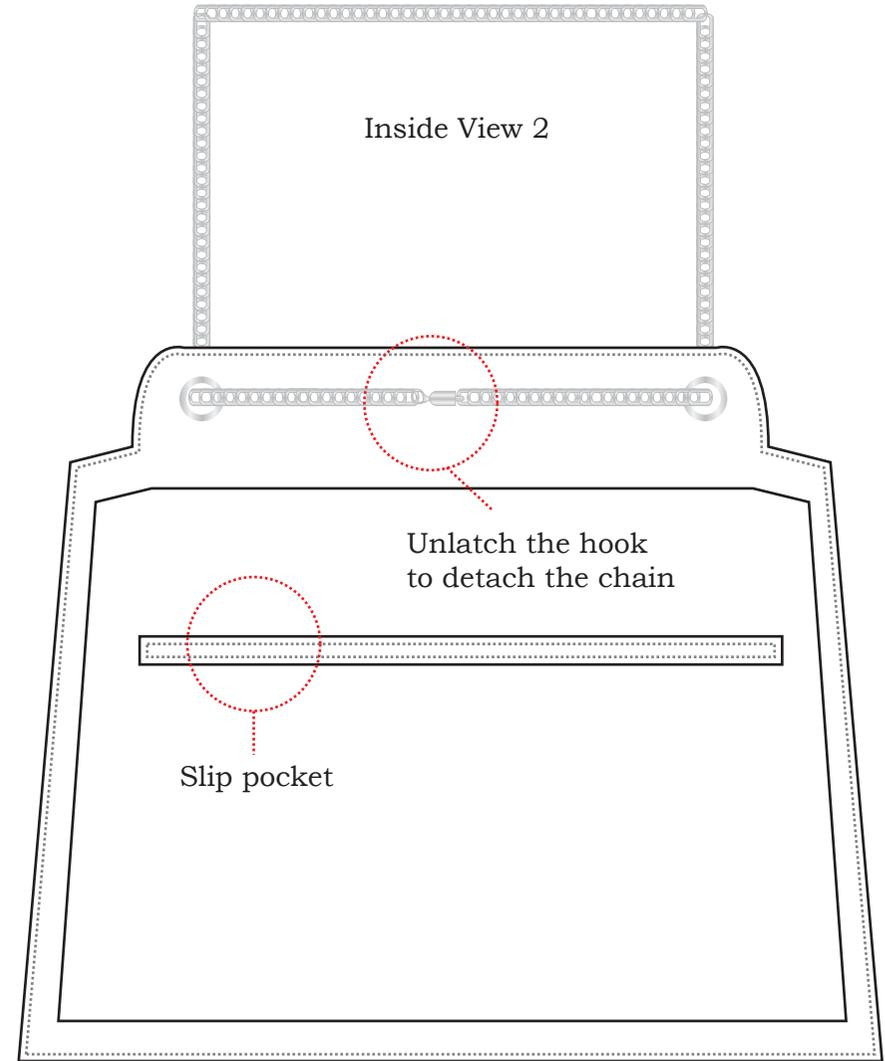
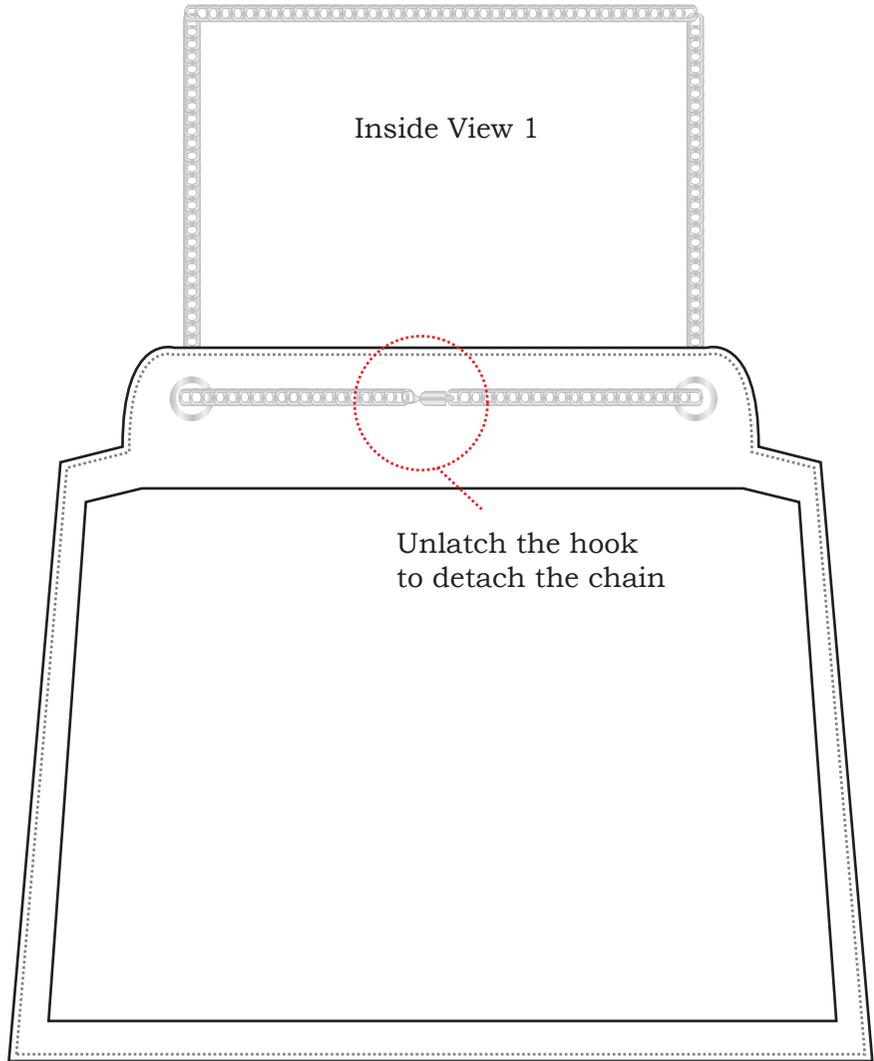





Out side opened view

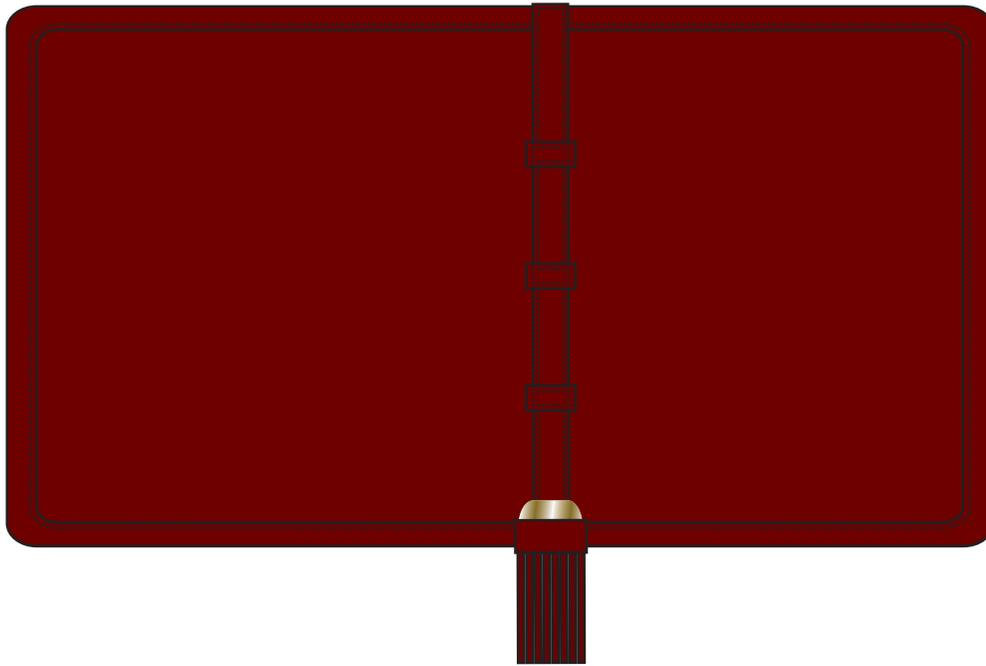

Front



tasle

inside opened view

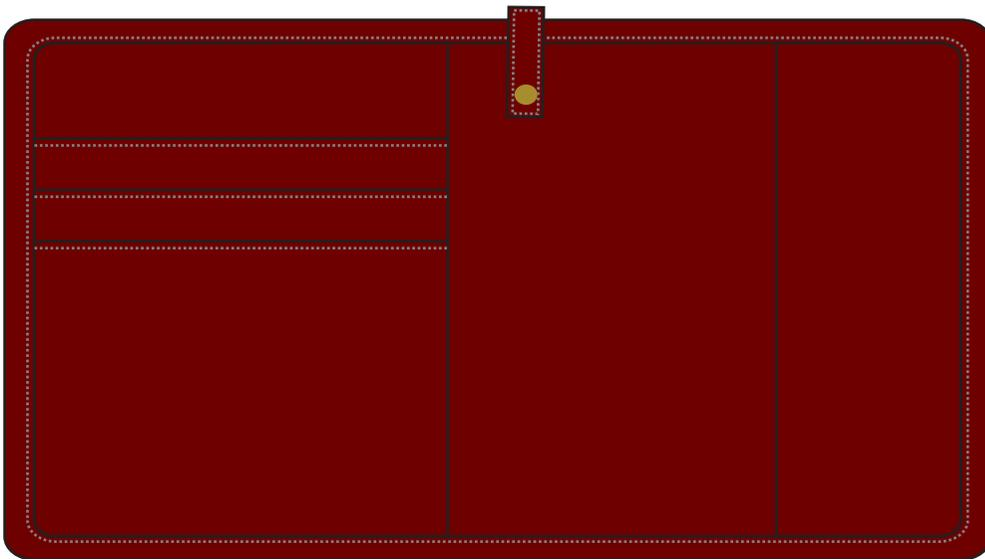

Back

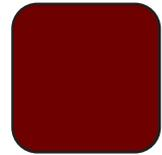

Genuine leather  
Maroon

Ramayana

Out side opened view



Front

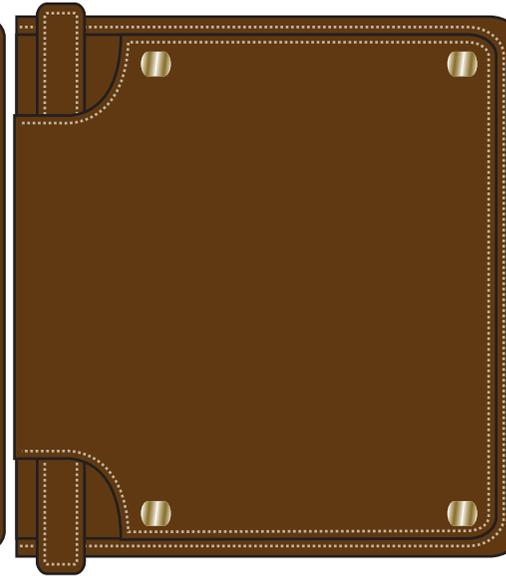

inside opened view

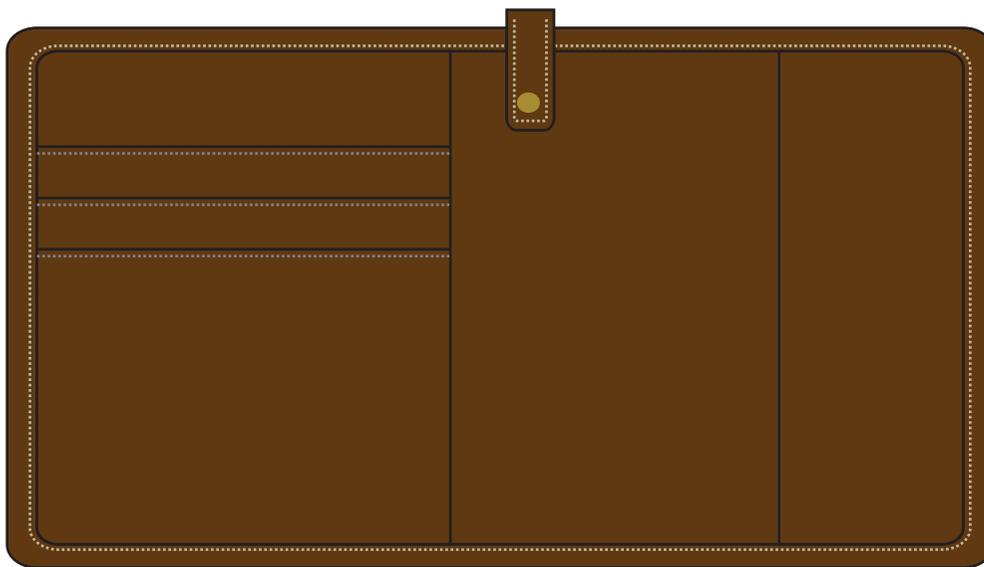

Back

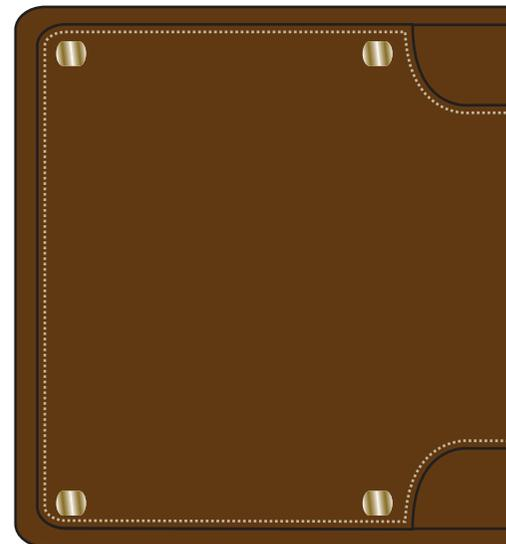

Genuine leather  
Brown

Purasuci



Out side opened view

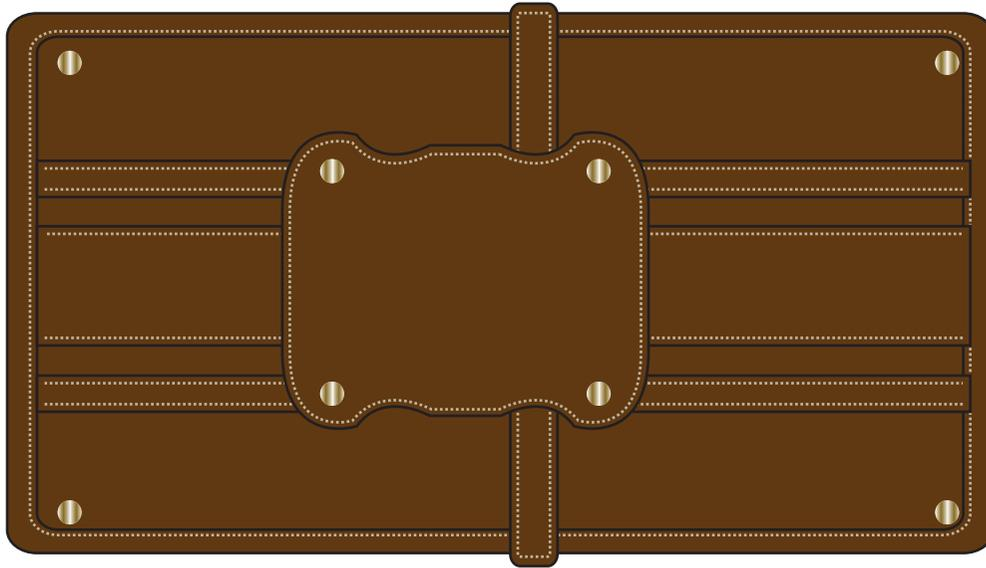

Front



inside opened view

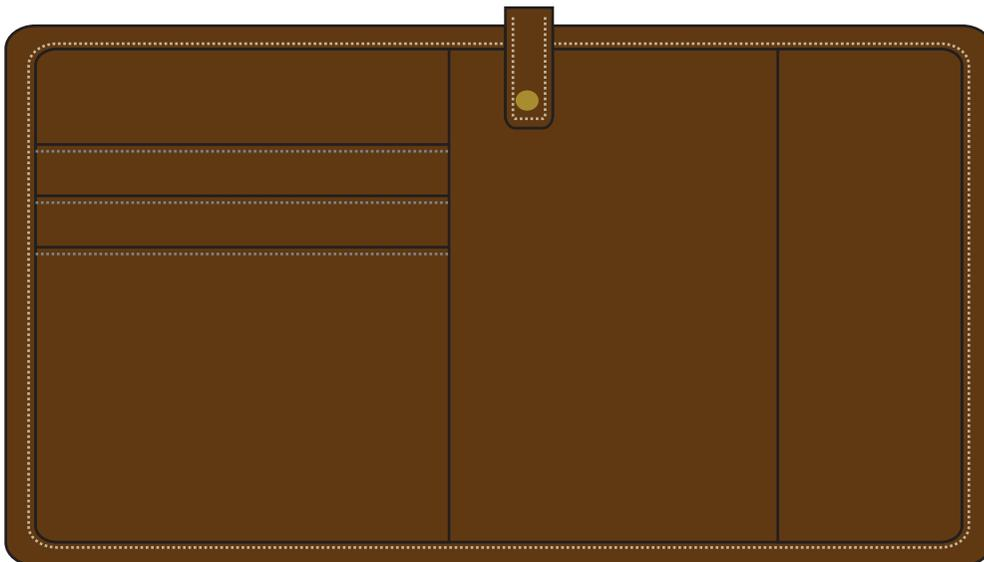

Back

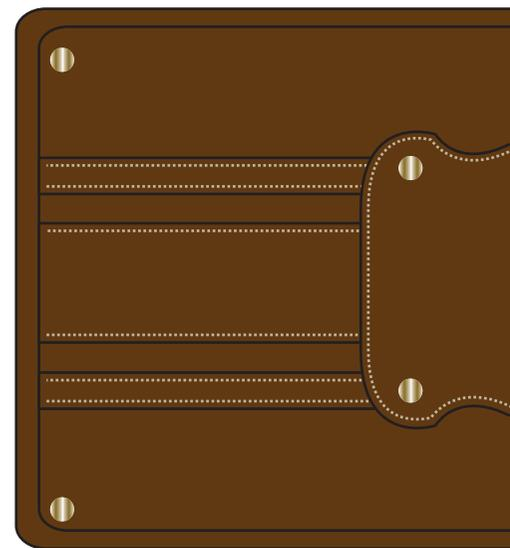

Genuine leather  
Brown

Sesajen

Out side opened view

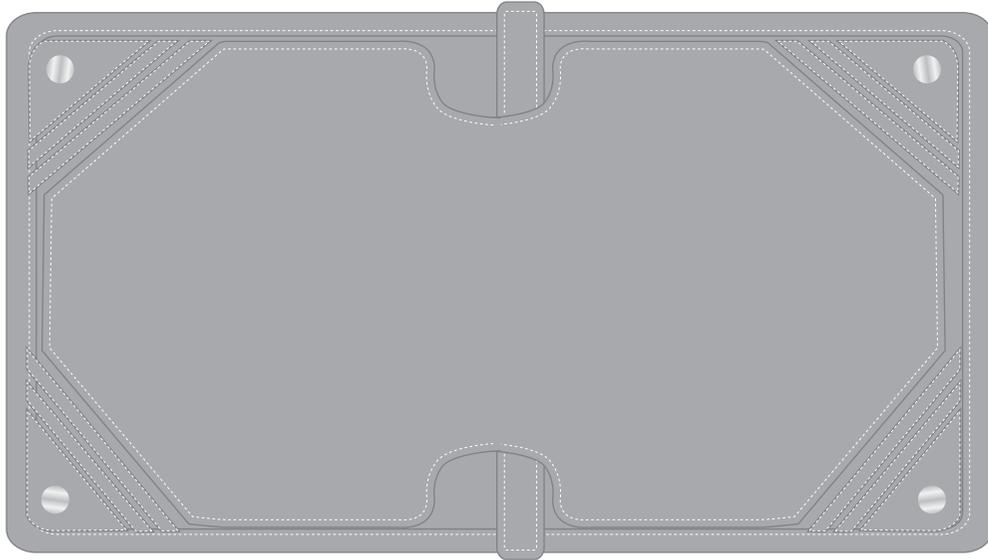

Front

Front

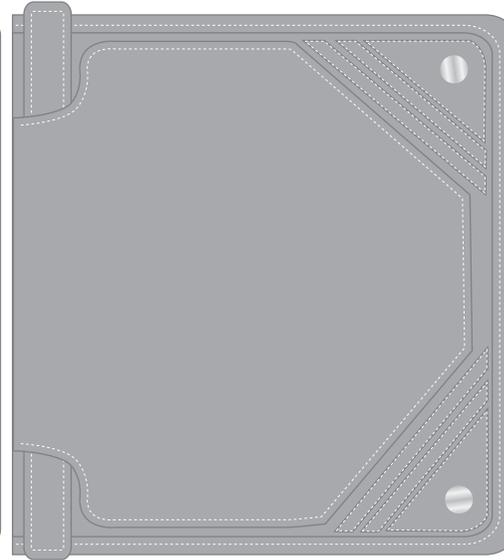

inside opened view

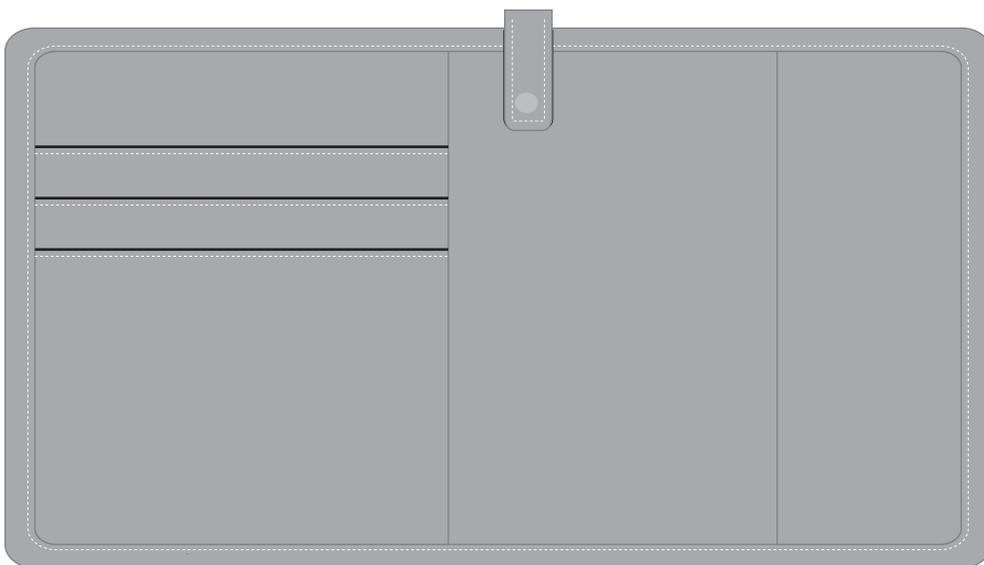

Back

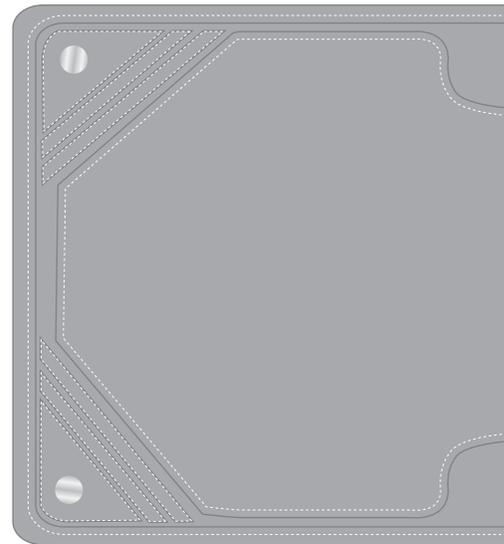

Genuine leather  
Light grey

# Nagatoya



Out side opened view

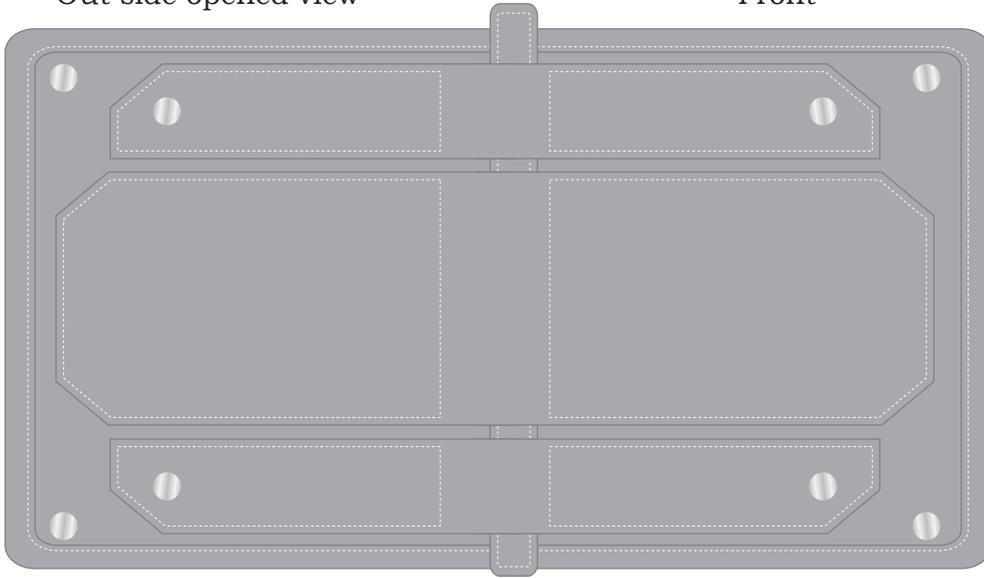

Front

Front

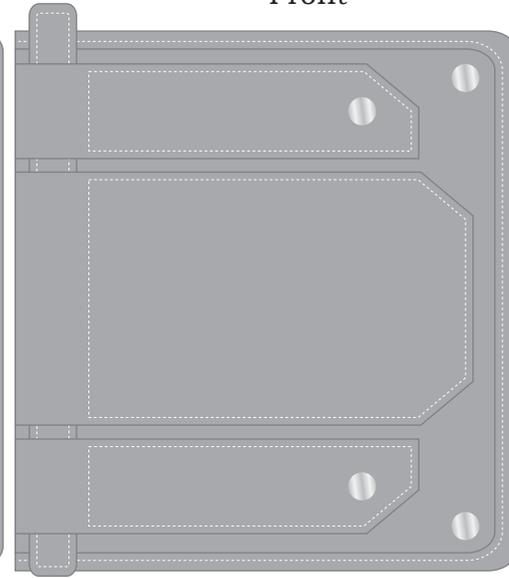

inside opened view

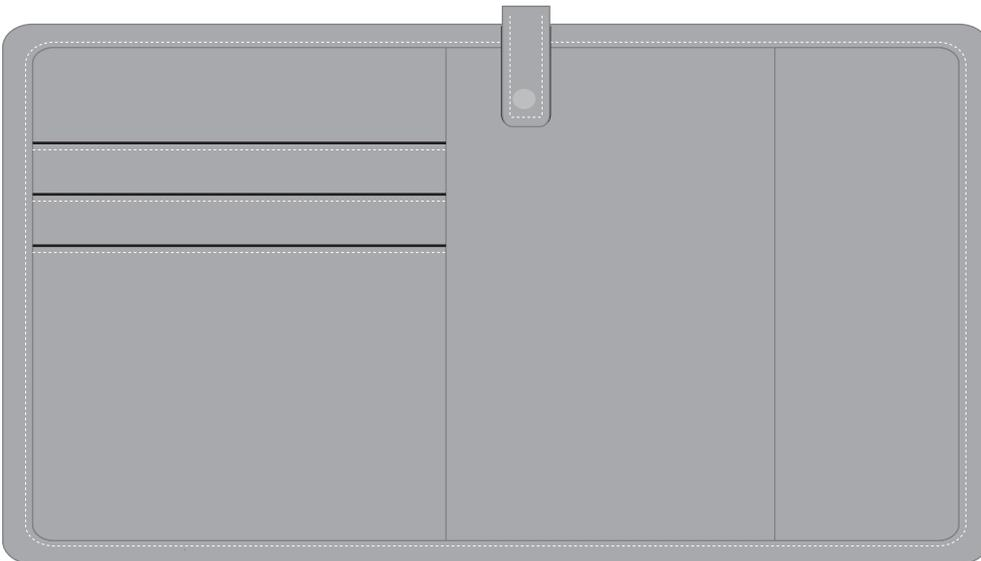

Back

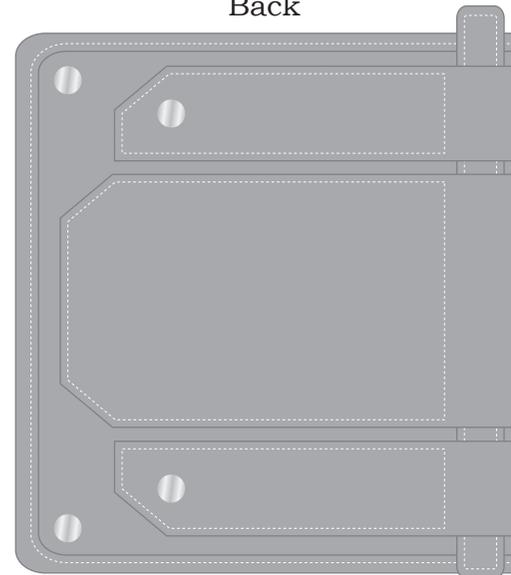

Genuine leather  
Light grey





Front

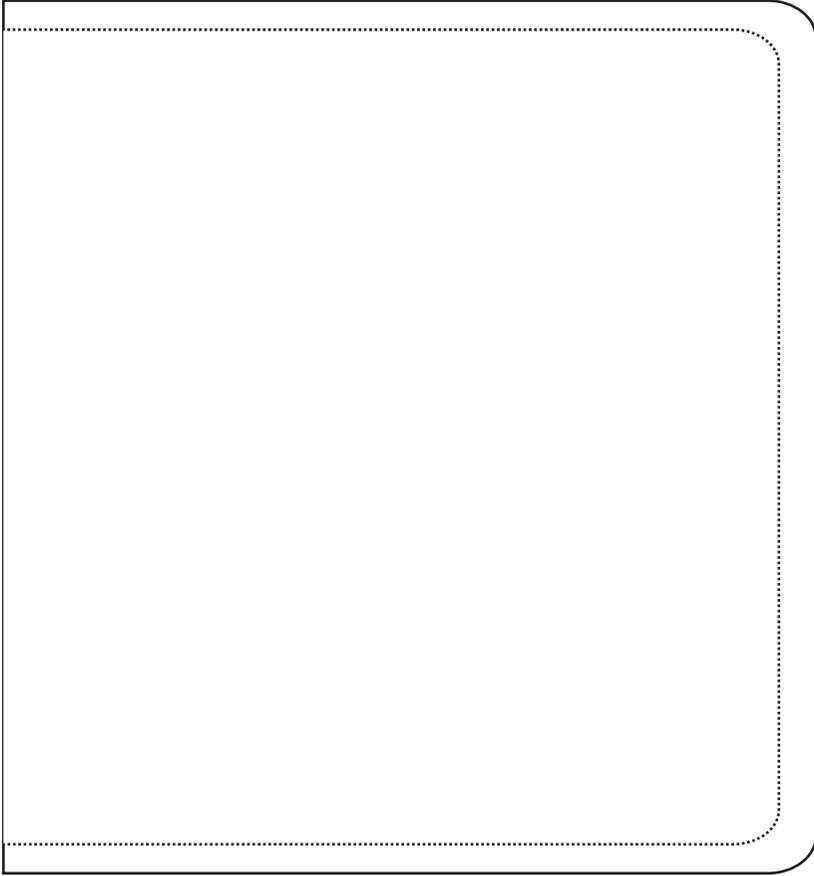

Back

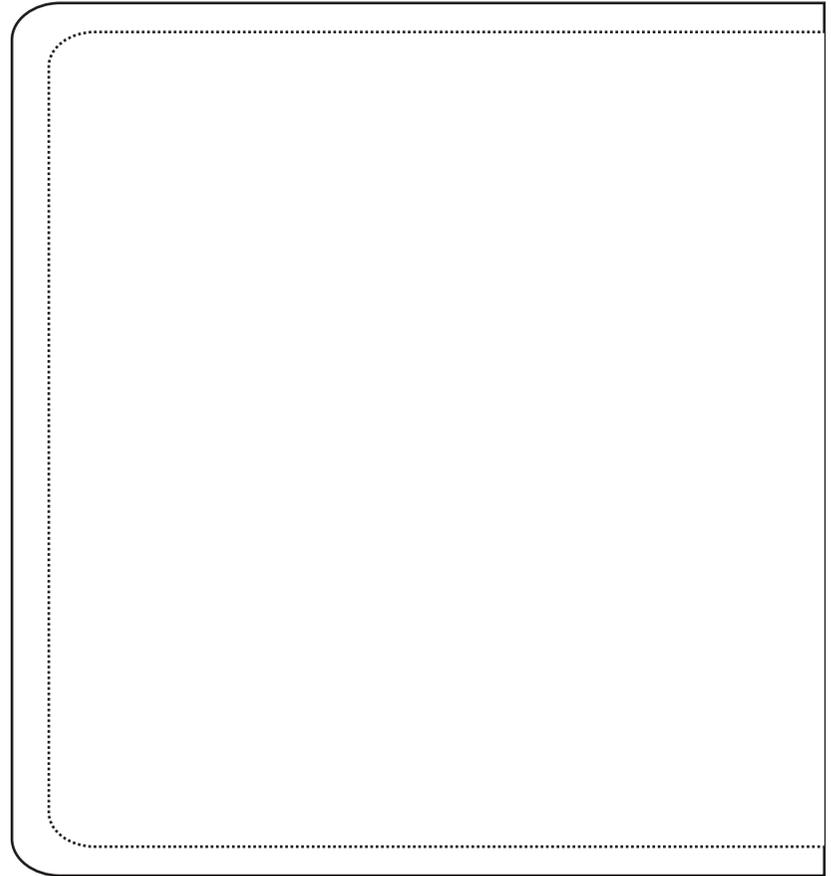

Out side opened view

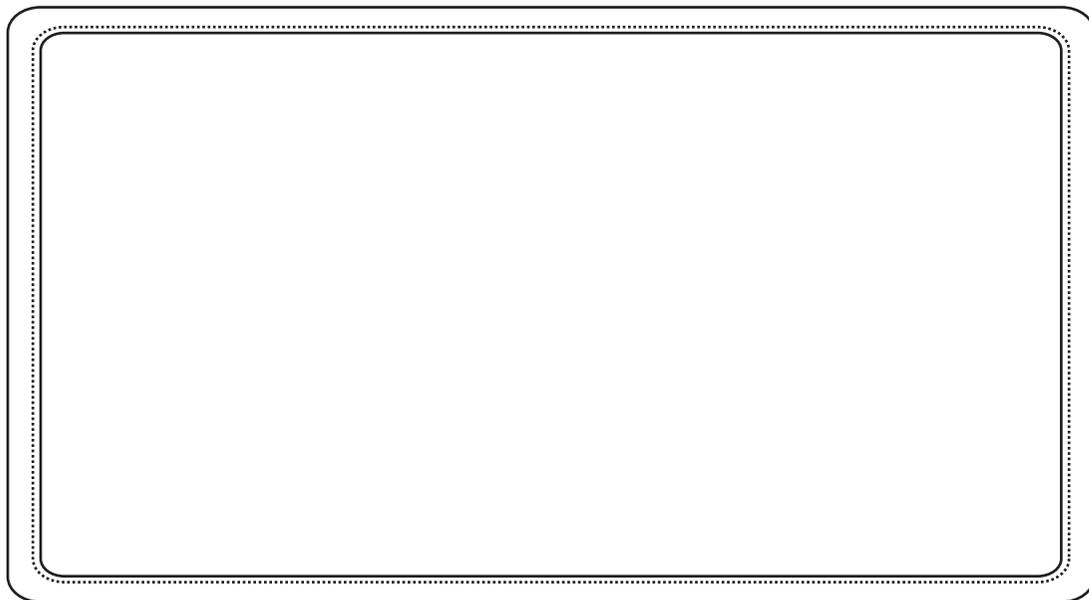

inside opened view

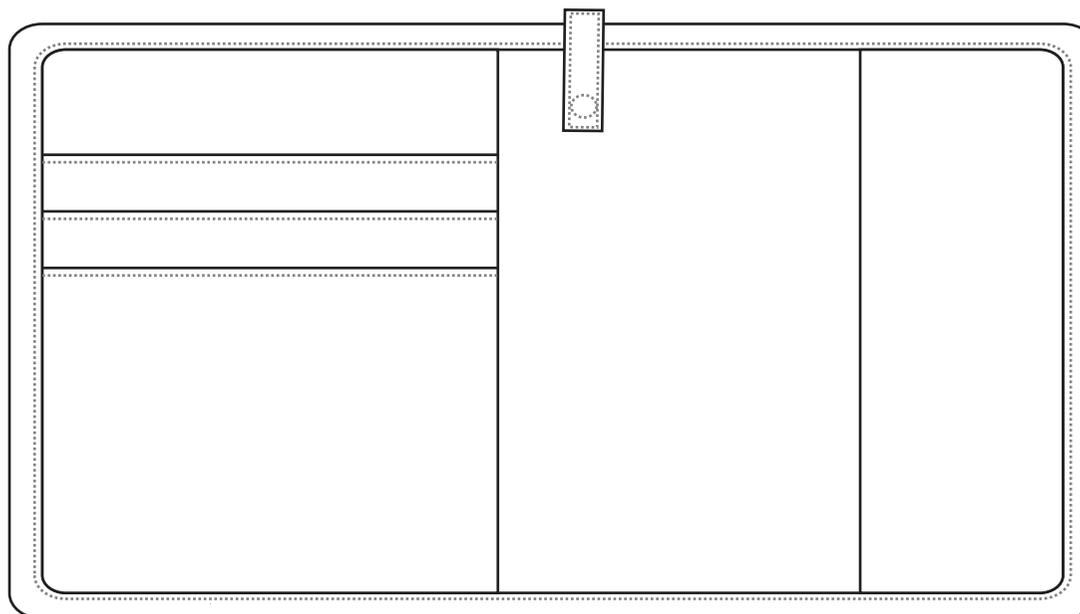

Size: 21.5 cm x 14 cm





Logo and Packaging design...



5.2 cm

7 cm

### Main Logo Design



2.5 cm

7 cm

### First Bag line Logo



### Logo Design

MahaRatu is an old Sanskrit word that means the Highest of the ultimate queen. For my logo I designed an image of the crown that would fit for the brand. I incorporate as well the rose thorn as a symbol of sharpness and filigree design as a symbol of softness. This brand represents both sides in meaning that my customer is the “MahaRatu” strong, independent yet attracted to beauty and fashion evolution. I choose the color Blood Red as a depiction of a royal color that signified with dignity and power. Under the crown design then the intricate name of the store is written. As for Folklore the launching first launching line from MahaRatu will be written in the same way as the writing for the Logo of MahaRatu.

## Logo Details



Logo for the bags will be embroidered on top of the canvass Creme or warm grey using Cotton nylon thread in maroon and silver. Inline stitches will be added will same color thread. Rustic Gold and silver studs will be added as the frame of the logo.

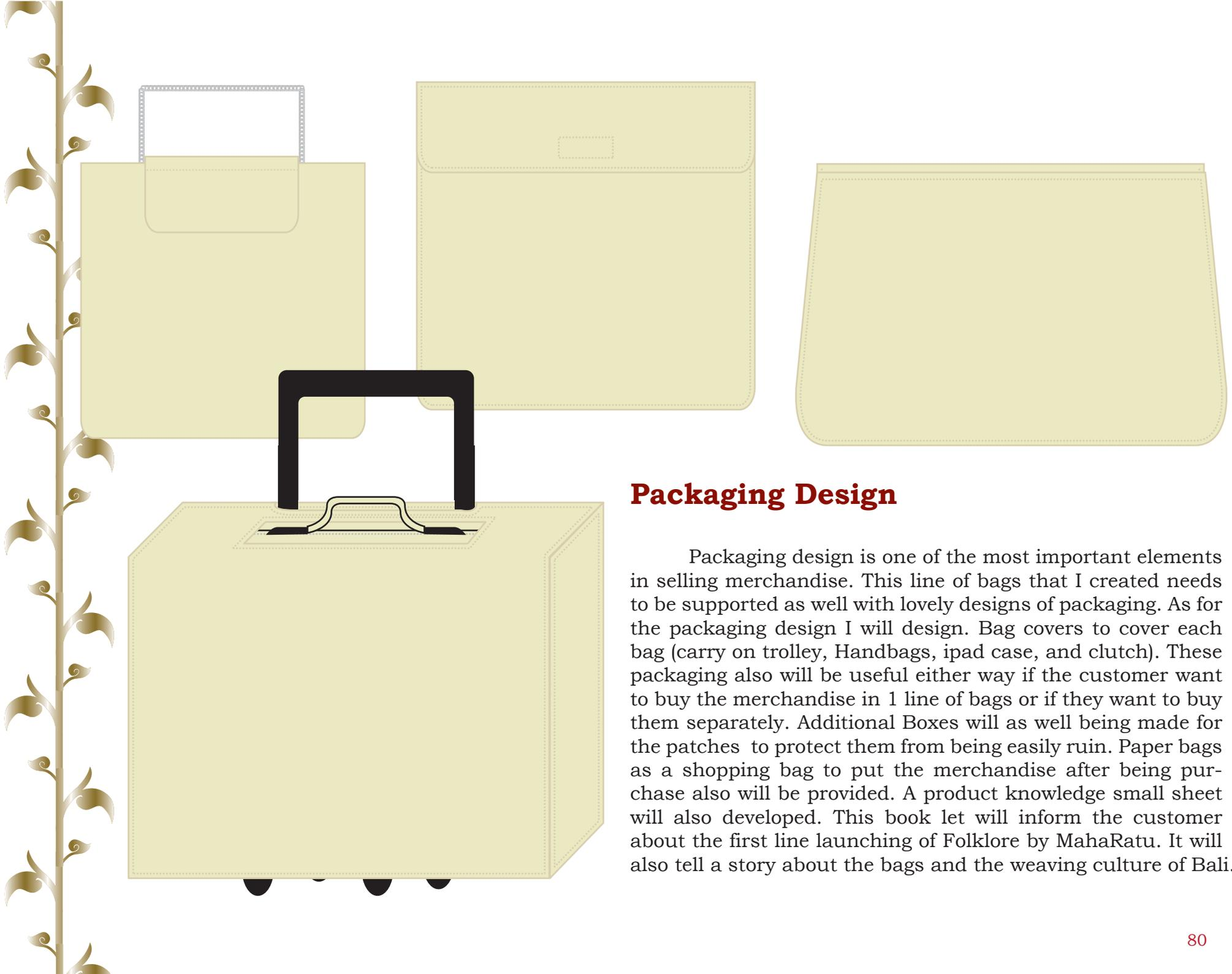

## **Packaging Design**

Packaging design is one of the most important elements in selling merchandise. This line of bags that I created needs to be supported as well with lovely designs of packaging. As for the packaging design I will design. Bag covers to cover each bag (carry on trolley, Handbags, ipad case, and clutch). These packaging also will be useful either way if the customer want to buy the merchandise in 1 line of bags or if they want to buy them separately. Additional Boxes will as well being made for the patches to protect them from being easily ruin. Paper bags as a shopping bag to put the merchandise after being purchase also will be provided. A product knowledge small sheet will also developed. This book let will inform the customer about the first line launching of Folklore by MahaRatu. It will also tell a story about the bags and the weaving culture of Bali.

## A short product knowledge

Open view

Inspired by the closeness of the priestess's family here in sidemen village, Bali, by the humble and simple life style that the thought me through balanced and patience to create an elaborate beautiful songket, I focused my thesis projects on developing more on how to make the motifs they use on their songket more well known to the western world. As I stated on my previous research that the songket in Bali is the only songket that actually has an articulate motifs of the gods with the story of epics Hinduism folklore.

Using these bags as a frame of part of the scene that was told in the Hinduism folklore that I was told during my stay with the priestess, I choose the motif that connect them together and try to show them in one line of bags as their media to tell these stories. I chose the folklore of Ramayana, Batarayudha, and Nagatoya. As for my other two lines of bags I chose the theme of Sesajen which means the offerings in Hinduism, and Puresuci which means the sacred temple.

Size: 5 cm x 19 cm



Front view

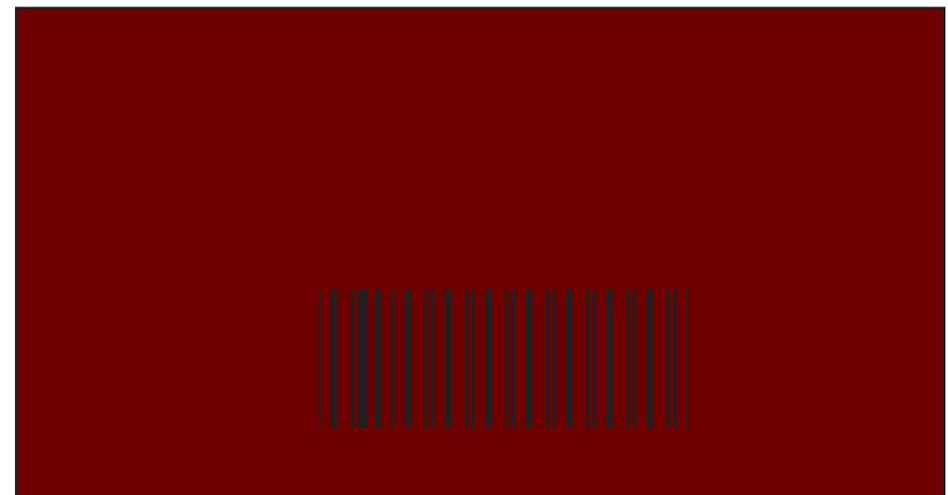

Back view

## Boxes For patches

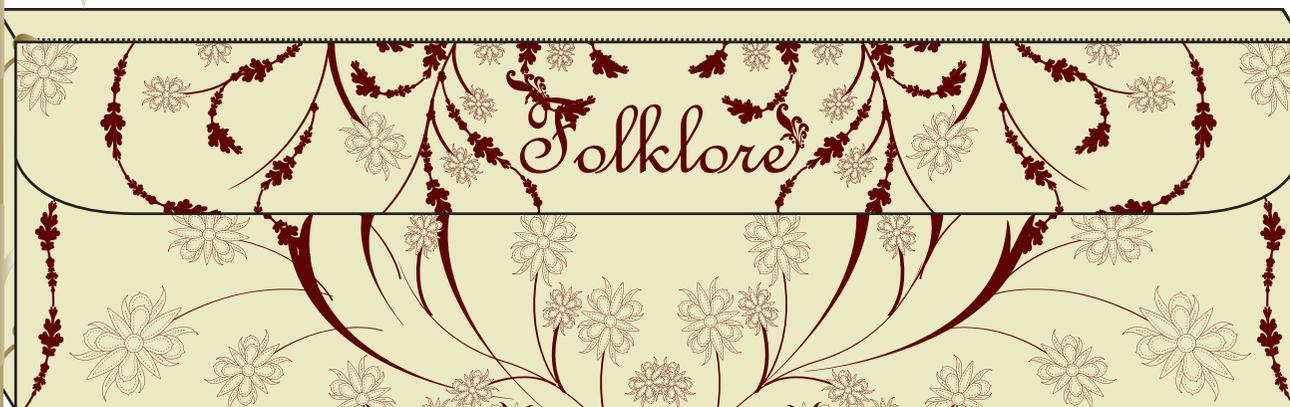

35 cm x 10 cm x 1 cm

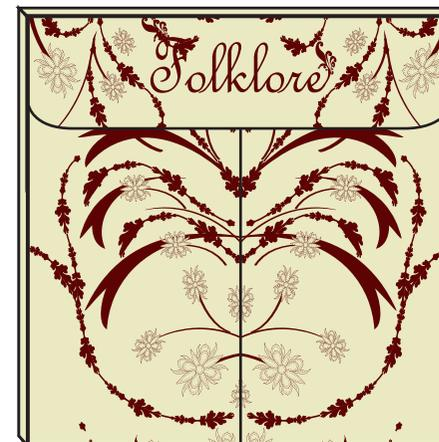

13 cm x 10 cm x 1 cm



27 cm x 25 cm x 1 cm

# Boxes In open details.

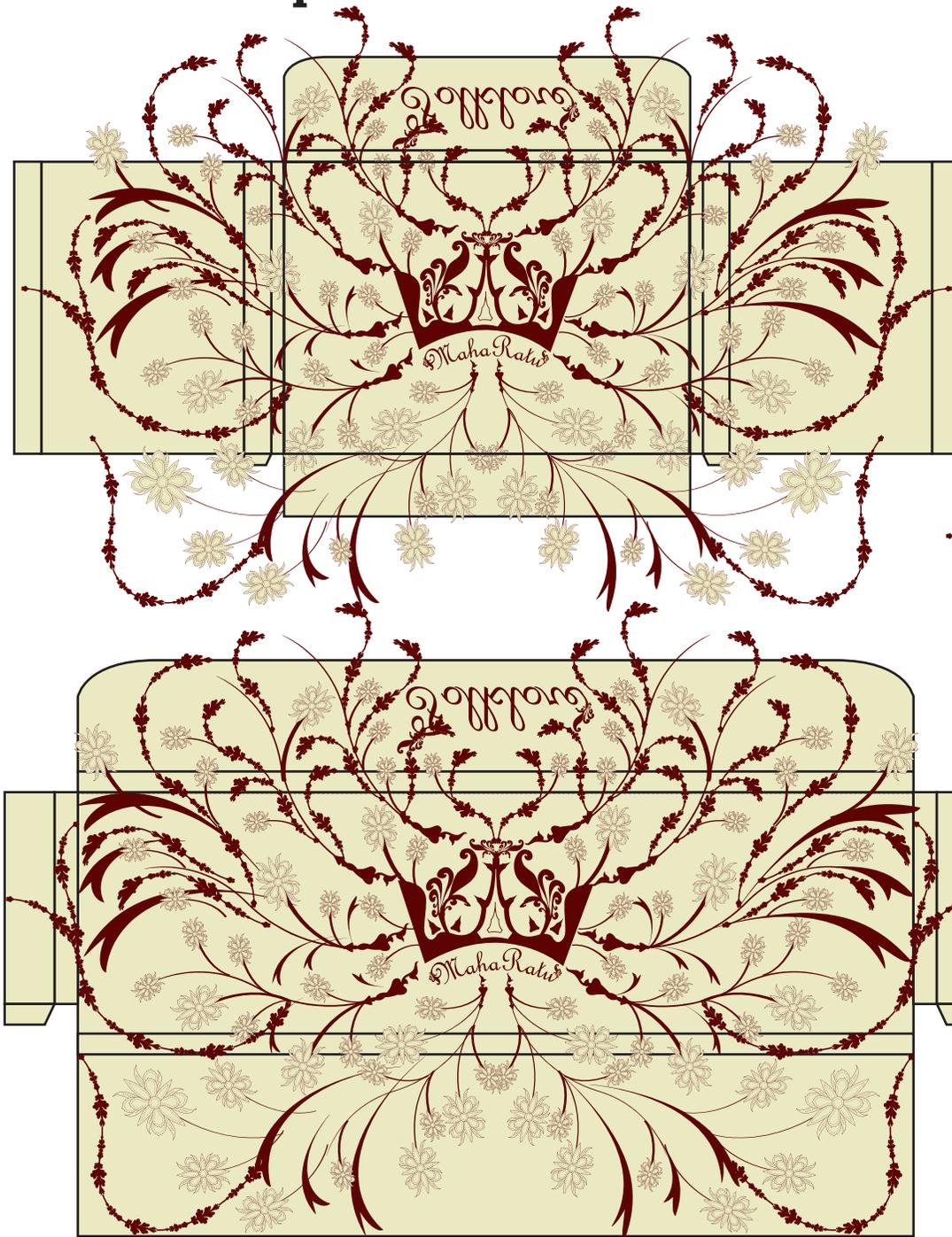



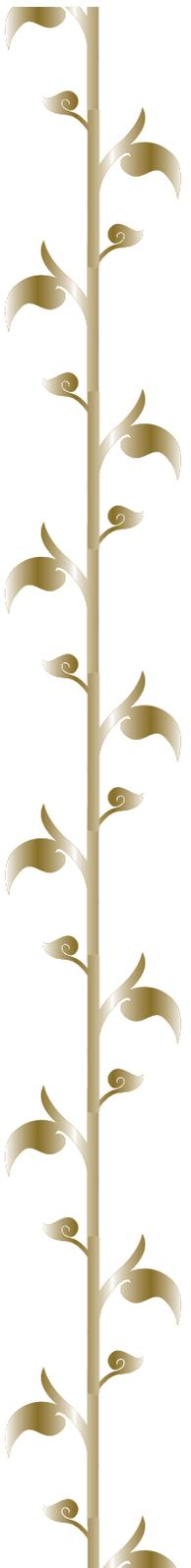

Product shot...











Showroom...



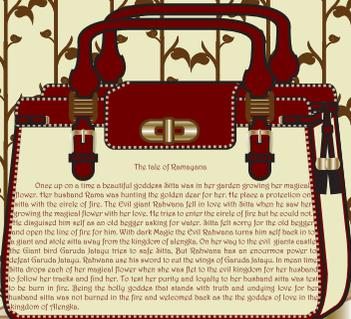

The tale of Ramayana

Once upon a time a beautiful goddess Sita was in her garden growing her magical flower. Her husband Rama was hunting the golden deer for her. He placed a protection on Sita with the circle of fire. The evil giant Rahwana fell in love with Sita when he saw her growing the magical flower with her love. He tried to enter the circle of fire but he could not. He disguised himself as an old beggar asking for water. Sita felt sorry for the old beggar and opened the line of fire for him. With dark magic the evil Rahwana turned him self back to his giant and stole Sita away from the kingdom of Alankap. On her way to the evil giants castle the Giant bird Garuda Jaijau tries to save Sita. But Rahwana has an enormous power to defeat Garuda Jaijau. Rahwana was the wiser to cut the wing of Garuda Jaijau. In mean time Sita drops each of her magical flower when she was flat to the evil kingdom for her husband to follow her tracks and find her. To test her purity and loyalty for her husband Sita was to be burn in fire. Being the holy goddess that stands with truth and undying love for her husband Sita was not burned in the fire and returned back as the goddess of love in the kingdom of Alankap.

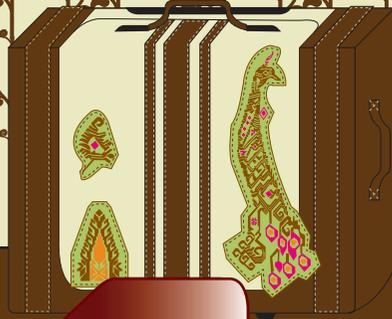
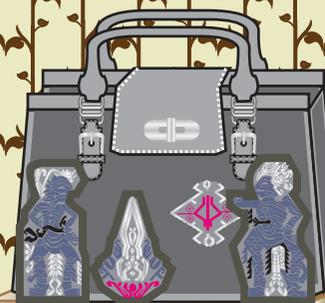

The tale of Ramayana

Once upon a time a beautiful goddess Sita was in her garden growing her magical flower. Her husband Rama was hunting the golden deer for her. He placed a protection on Sita with the circle of fire. The evil giant Rahwana fell in love with Sita when he saw her growing the magical flower with her love. He tried to enter the circle of fire but he could not. He disguised himself as an old beggar asking for water. Sita felt sorry for the old beggar and opened the line of fire for him. With dark magic the evil Rahwana turned him self back to his giant and stole Sita away from the kingdom of Alankap. On her way to the evil giants castle the Giant bird Garuda Jaijau tries to save Sita. But Rahwana has an enormous power to defeat Garuda Jaijau. Rahwana was the wiser to cut the wing of Garuda Jaijau. In mean time Sita drops each of her magical flower when she was flat to the evil kingdom for her husband to follow her tracks and find her. To test her purity and loyalty for her husband Sita was to be burn in fire. Being the holy goddess that stands with truth and undying love for her husband Sita was not burned in the fire and returned back as the goddess of love in the kingdom of Alankap.

