

POLITECNICO DI MILANO
I Facoltà di architettura
Laurea Magistrale - Architettura MI

SEWING UP CARACAS
Interpretation of the urban reality of the city and
project proposal for the integration of San Agustín
Neighborhood.

Supervisor
arch. Nicolo' Carlo M Riva

Co-supervisor
arch. Carla Collevchio

Author
Melanie de los Angeles Acosta Perez
matr. 796170

academic year 2014-2015

ABSTRACT

The topic of the following thesis is a response to the personal interest of the author in relation to her hometown city, being the main purpose to examine and reflect on the fragmented urban reality of the city of Caracas, the events through history that generate its features, the problematics due to segregation and inequality that it produces, recognizing different fragments with unique characteristics, point out where in the city these fragments collide and then develop an integration proposal for one of them, taking into account the specific requirements of the place, setting up a strategy and ultimately, a project proposal to define the borders of the critical fragments and strengthen the existing connections with a hybrid building that combines housing, commercial activities, services and public space.

The thesis is divided into two main sections, the first is dedicated to the city while the second is dedicated to the neighborhood selected to develop the proposal, including text, maps, schemes and technical drawings by the author, accompanied by photographs and satellite images to enable the understanding of the raised issues.

Il tema della seguente tesi è una risposta all'interesse personale dell'autore in relazione alla sua città natale, essendo lo scopo principale di esaminare e riflettere sulla realtà urbana frammentata della città di Caracas, gli eventi attraverso la storia che generano le sue caratteristiche, le problematiche dovute alla segregazione e disparità che essa produce, riconoscendo diversi frammenti con caratteristiche uniche, sottolineando dove in città questi frammenti si scontrano e poi sviluppare una proposta di integrazione per una di loro, tenendo conto delle esigenze specifiche del luogo, l'impostazione una strategia e, in definitiva, una proposta di progetto per definire i confini dei frammenti critici e rafforzare i collegamenti esistenti con un edificio ibrido che combina abitazioni, attività commerciali, servizi ed spazi pubblici.

La tesi è divisa in due sezioni, la prima è dedicata alla città, mentre la seconda è dedicata al quartiere scelto per realizzare la proposta, tra cui testo, mappe, schemi e disegni tecnici dall'autore, accompagnano fotografie e immagini satellitari per consentire la comprensione delle questioni sollevate.

TABLE OF CONTENT

INTRODUCTION

CARACAS_COLLAGE CITY

a. Historical Outline

- Foundation & Urban Sprawl
- The role of the oil industry, state policies, natural disasters and social housing initiatives in the transformation of the city

b. Urban Inequalities

- Residential Employment & Leisure areas
- Formal vs. Informal

c. Fragment Types

- Compact
- Isolated
- Consecutive
- High-rise
- Industrial
- Organic
- Superblock
- Spontaneous

d. Fragment Collision

SAN AGUSTIN_PATCHING UP THE NEIGHBORHOOD

e. The Place

f. The Strategy

g. The Network

h. The Building

- Volume
- Program
- Public Space

BIBLIOGRAPHY

IMAGE CREDITS



CARACAS_COLLAGE CITY

Collage: (noun) A design or picture made up of pieces of paper or cloth, attached to a background surface.

Caracas is the result of the addition of many *pieces*, each with their own features, that when joined or overlapped one over the other create an heterogeneous urban reality.

The *background surface* to which these pieces attach to is the topography of a valley around 900mts above sea level, with the Avila mountain chain to the north (Pico Naiguata at around 2700mts high), smaller hills to the south and a network of river streams that combined with the Guaire river subdivide and break the central valley in several sectors.

The image or *picture* of the city nowadays is the result of many events during history, from the chosen place for its foundation to the following trasformations, considered one of the most violent and chaotic urban growths in the cities of Latin America.

The private sector is mostly the responsible of the city expansion, with neighborhoods detached one from the other and progressively moving away from the city center serching for territories easier to develop. Too much importance to the use of th private vehicle and as a consequence a neglected street life.

A city made by segregated areas for residential, employment and leisure, while the rest is dedicated entirely to transportation, transition and movement, encouraged by a strong investment of the public sector in roads infrastructure that will leave a mark in the urban landmark and easy access to asphalt, a product of the national oil industry.

Wealth and the impulse to modernize this developing country will allow the implementation of international models like the superblock, almost exclusively theoretical at the time, among other ground breaking developments such as the construction of El Helicoide, Parque Central complex, the Humboldt hotel and the Ciudad Universitaria de Caracas, nowadays decayed but still city landmarks.

Most of these developmets will take place in the capital, neglecting the rest of the country and eventually leading to massive migrations looking for a better life and opportunities in Caracas that will also lead to the creation of informal settlements due to the housing market shortage.

Fragmentation, inequality, contrast, segregation and a problematic urban reality caused by discontinuity and ruptures between its parts.

HISTORICAL OUTLINE

FOUNDATION AND URBAN SPRAWL

Founded around 1567 with the name of Santiago de Leon de Caracas belonging to the Spanish colony Capitanía General de Venezuela, that because of its strategic position towards the Caribbean sea and the absence of complex indigenous cultures, was classified with only military importance resulting in modest colonial architecture compared to other Spanish cities such as Mexico city, Cuzco or La Habana.

The grid configuration is the same that is used with small variations in all the Spanish colonies from Mexico city to Buenos Aires, orthogonal streets that put together compact blocks of continuous buildings and a central square or Plaza Mayor where the social activities take place.

Gold hunting and exploration could be the reasons why the city is founded close to the road that allows the access through the Avila mountain formation from the coast to the innerlands (Camino de los Espanoles) and not deeper into the valley, placed instead between the Caroa and Cachuca water streams to the north of the Guaira river.

The colonial urban pattern remains untouched until 1870 with the arrival of the president Guzman Blanco that will pursue the "westernization" of the provincial culture and aspect of the city with an investment on public services with a modest and "tropicalized" version of what was taking place in Europe at the moment. Enlargement with same modules.

The first expansion outside the grid occurs at the end of the XIX century with the inclusion of the existing plantation ranches to the urban area, with the interest of landlords and owners of transportation companies.

First towards the south and then aggressively developing towards the east will cause the so called "city center" to be placed in fact in the geographical west of the nowadays metropolitan area.

It is mostly the private initiative the one in charge of the city enlargement. Each neighborhood arranges and subdivides individually an area of the valley with no relation to the colonial urban pattern, with the exception of some neighborhoods such as El Conde and San Agustin that preserve the compact and repetitive structure of the old city with smaller modules.

This new neighborhoods consistently adopt the typology of the isolated villa surrounded by gardens coming from the european ideals and concepts of the "Garden City", exclusively as a matter of fashion since the pressures and conditions that this movement was fighting against, for example high levels of air pollution due to industrialization, did not exist in Caracas at the time.

around 1578

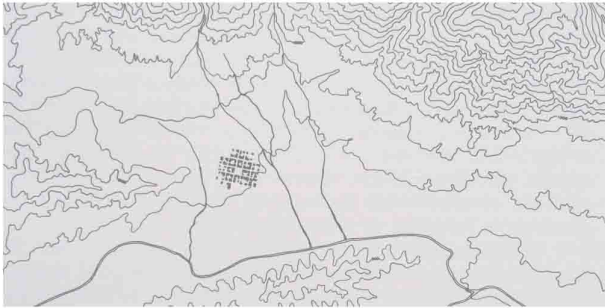

around 1690

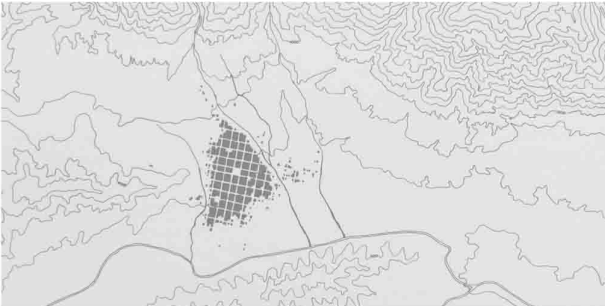

around 1806

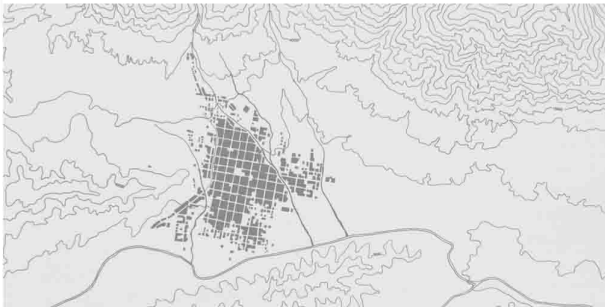

around 1897



URBAN SPRAWL

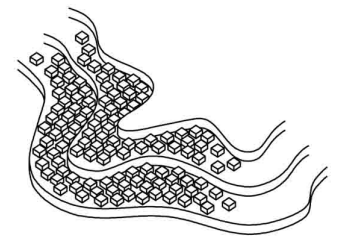
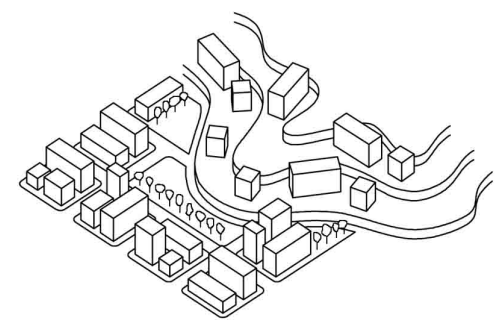
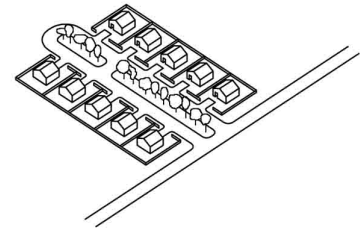
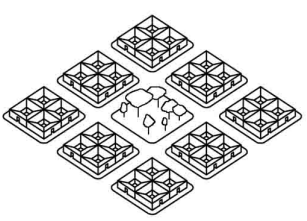
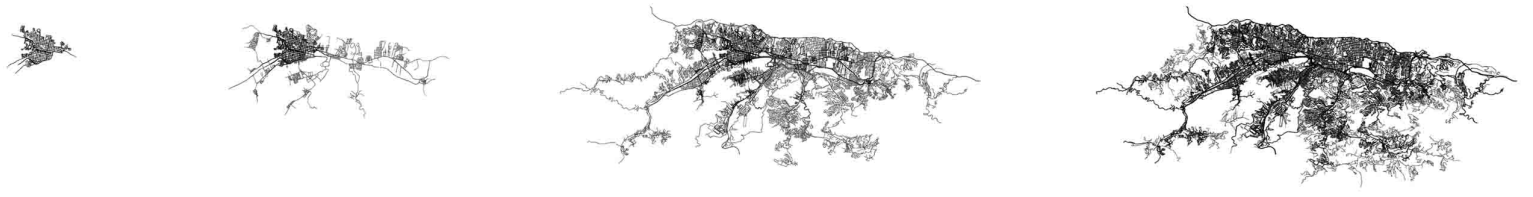

The first to be developed is the neighborhood El Paraíso, side by side with the appearance of the "suburb-vehicle" relationship that will only strengthen from that moment on, leading to the abandonment of the pedestrian city.

Later on, the city continues its expansion and densification with the inclusion of the typology of the high-rise.

The State contribution towards the urbanism is made in the form of roads infrastructure such as highways, tunnels, connections and bridges. There is also public investments in services infrastructure but soon enough is not sufficient to supply the demand of the growing population.

Land plots in the lower area of the valley are running out and the developers ignore the hills nearby the city center looking for horizontal areas that are easier to develop although farther away.

Illegal occupation of the leftover areas around and within the city such as hills and water streams edges with improvised constructions that will consolidate through time, giving shape to problematic and unstable high density areas with no access to adequate sewage, water or electricity infrastructure, living at the margin of society.

THE ROLE OF THE OIL INDUSTRY, STATE POLICIES, NATURAL DISASTERS AND SOCIAL HOUSING INITIATIVES IN THE TRANSFORMATION OF THE CITY

In 1878 the oil exploitation starts with a small refinery in Tachira, at the west side of the country. 40 years later begins a large scale exploitation resulting in international investments in the sector until Venezuela joins the global market as a major oil supplier.

Cultural and technological exchange besides an increment on the State income that will be destined among other things to the enhancement and modernization of the capital city.

In 1928 the Banco Obrero was founded, an institute belonging to the State to promote social housing initiatives in order to help the low-income workers to purchase a house within the urban area of the city. The first to be developed was the neighborhood of San Agustín Sur, single family housing of one floor arranged into passageways. With similar features were later developed the neighborhoods of Pro-Patria and Bella Vista.

Now the oil is the first income source of the country, surpassing the coffee, the cocoa, agriculture and cattle raising.

Starting from 1943 with the Ley de Hidrocarburos and then in 1945 with the Reforma Petrolera, the revenues from the oil industry increase even more the State income.

Strong investments in public infrastructure that will continue for a while thanks to the increase of oil production to supply the demand of the global market after the WWII, and thanks to the appealing conditions and warranties agreed between the transnational companies and the State (several consecutive military governments).

Accelerated population growth caused both by large scale migration of people that move from the countryside to the city looking for job opportunities in the building construction sector and an open door policy for European migration for those running away from the war.

With the arrival of democratic governments and the creation of the Corporación Venezolana de Petróleo in 1960, the State now participates actively in the oil industry sector and declares a policy of no more international grants and concessions.

To meet the housing demand caused by the new city population, the private sector relies on the development of new neighborhoods away from the city center and the construction of high-rise buildings while the public sector, through the Banco Obrero, is devoted to the construction of superblocks. The first were erected apart from each other in different areas like Cerro Grande and Quinta Crespo, until 1954 when the Cerro Piloto plan puts them together in aggregations intended to substitute entire areas of informal settlements that had been growing in parallel to the formal city.

In 1967 a 6.5/6.7 Richter scale earthquake takes place 20km away from the city center causing around 300 deaths and the collapse of buildings in areas such as Altamira and Los Palos Grandes.

The oil industry is nationalized in 1975 during the first presidency of Carlos Andrés Pérez and now the whole economy of the country depends entirely on this industry. For the moment this will not represent a problem thanks to the high market price of the oil, promoted by the OPEC from which Venezuela is a founder member alongside Iran, Iraq, Kuwait and Saudi Arabia, but will begin to drop gradually starting from 1983.

The international and the private investment decreases for lack of trust in the national economy. Transnational companies reduce their activities in the country to increase it in Africa and the Middle East. Less production, more inflation, higher external debt, and at the same time the construction of the first line of the Metro de Caracas and cultural buildings such as the Teresa Carreño theater.

Economic measures are applied to deal with the external debt, leading to the social outburst El Caracazo in 1989, two failed attempts to overthrow the government of Carlos Andrés Pérez in its second presidency in 1992 and a crisis in banking and financial sector in 1994.

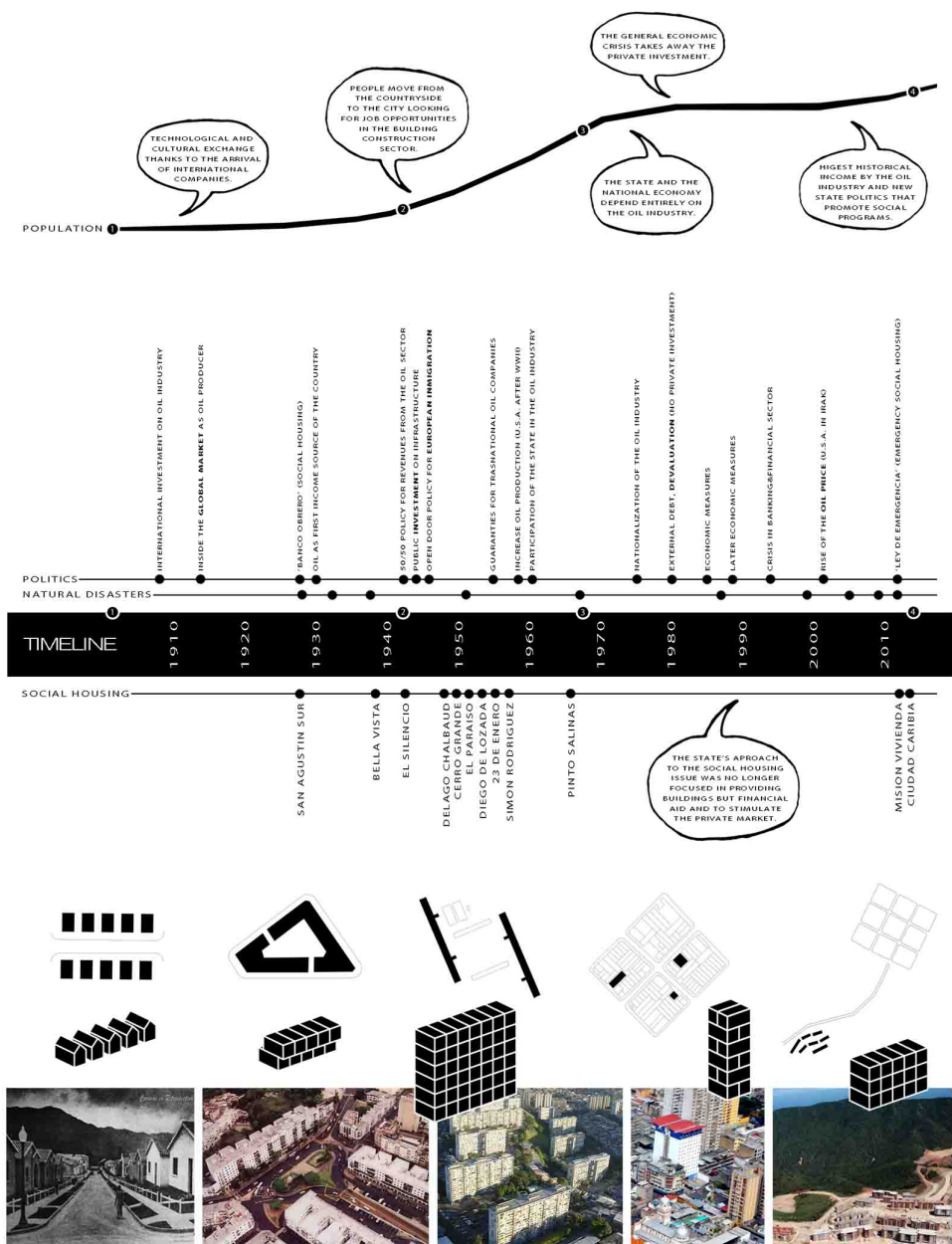

Democratic governments approach the social housing issue now with financial aid, subsidies and facilitation of credits instead of providing the buildings themselves, relying on the constructions and development from the private sector. Informal settlements keep growing.

In 1999 the Tragedia de Vargas catastrophe takes place in the seaside city of La Guaira where the international airport associated with Caracas is located. The worst natural disaster of the country in the XX century, causing around 10.000/30.000 deaths and featured in the Guinness World Records as the "Highest mudslide death toll" leaving also a large number of survivors, now homeless, that will eventually move out looking for shelter and assistance in the capital city where the national authorities are.

In 2009 another 6,2/6,3 Richter scale earthquake takes place, this time at 300km from the city center, intense rainfall during 2005 and 2010, with minor consequences for the formal city but with significant damage to the informal settlements in unstable land and adjacent to river streams.

In 2011 with the Ley de Emergencia, the State declares all public and private pieces of land apt for construction that are idle, abandoned or underused to be considered of public utility and destined to the construction of social housing.

State policies aimed at social housing initiatives and a variety of other social programs are supported by oil market prices around 100\$ in the years from 2011 to 2014.

High-rise residential buildings erected in the target spots inside the overcrowded urban fabric. New residential neighborhoods developed in the periphery of the city. No significant investment in new service infrastructure and deterioration of the existing ones.

POPULATION DENSITY (HAB/HA)

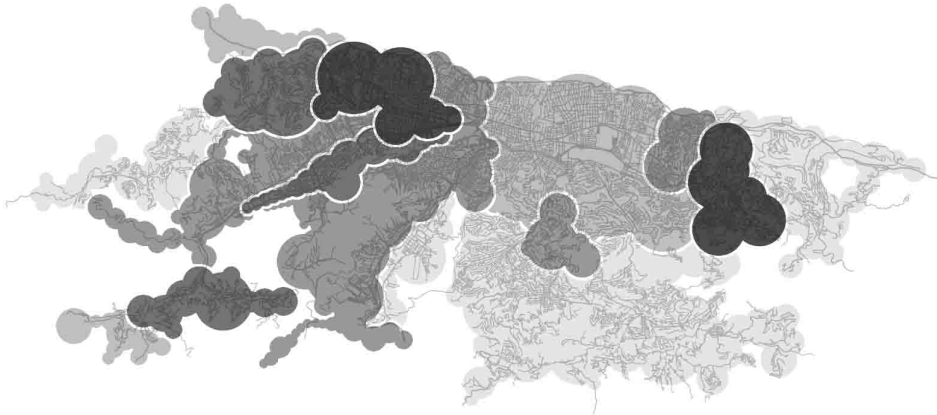

EMPLOYMENT DENSITY (HAB/HA)

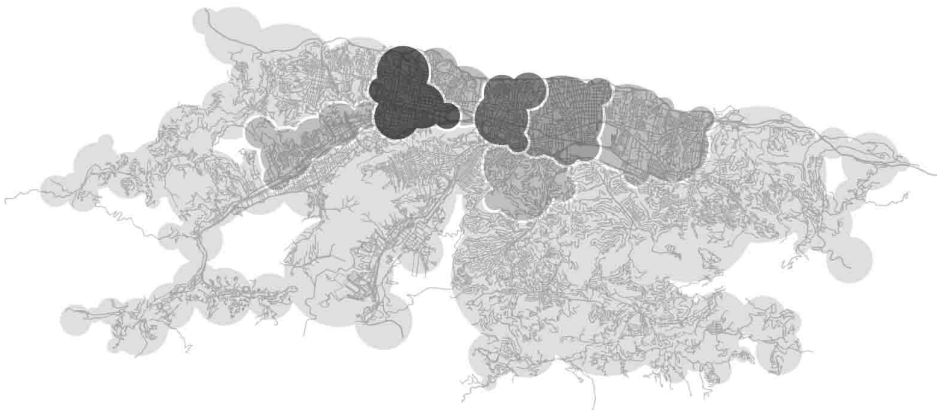

URBAN INEQUALITIES

RESIDENTIAL, EMPLOYMENT AND LEISURE AREAS

In 2010 the estimated population for the metropolitan area of Caracas was 3.220.54 inhabitants unevenly distributed through a surface of 313Km², with a high density area to the west (city center and nearby areas) and another to the east (Petare, group of informal settlements).

The residential areas are the ones that occupy the largest part of the urban surface and are made up by neighborhoods of both single-family and multi-family buildings, both private and public.

The employment areas include commercial activities, professional and financial services, industry, among other job-providing operations. The city center is where most of this activities concentrate, holding up to 20% of the jobs in the city, the rest is mostly distributed along an axis that cuts the city from east to west and few isolated areas.

The public space lacks continuity, the areas dedicated to leisure and sports behave like isolated elements, insufficient and badly distributed in relation to the population density. Public squares are left abandoned and put as a second option since people now prefer large shopping malls as places for meeting, gathering and recreation.

The mobility network is directed towards the use of the car while sidewalks, boulevards and pedestrian areas in general do not receive an adequate importance, contributing even more to a fragmented city made out of segregated point where to live, points where to work, points where to relax and the rest are just shifts from one point to the other.

Because of the violence in the social context and the problematics of the public space, people is forced to find (if is possible) inside the limits of their own dwelling what the city fails to provide, weakening even more the street life and social casual encounters.

The areas indicated in the map as residential, employment and leisure represent only the dominant activity while the other can also be present however, in a smaller proportion. They are not homogeneous. The entire city is made out of variety of urban types, some examples will be presented further on.



RESIDENTIAL



EMPLOYMENT



LEISURE

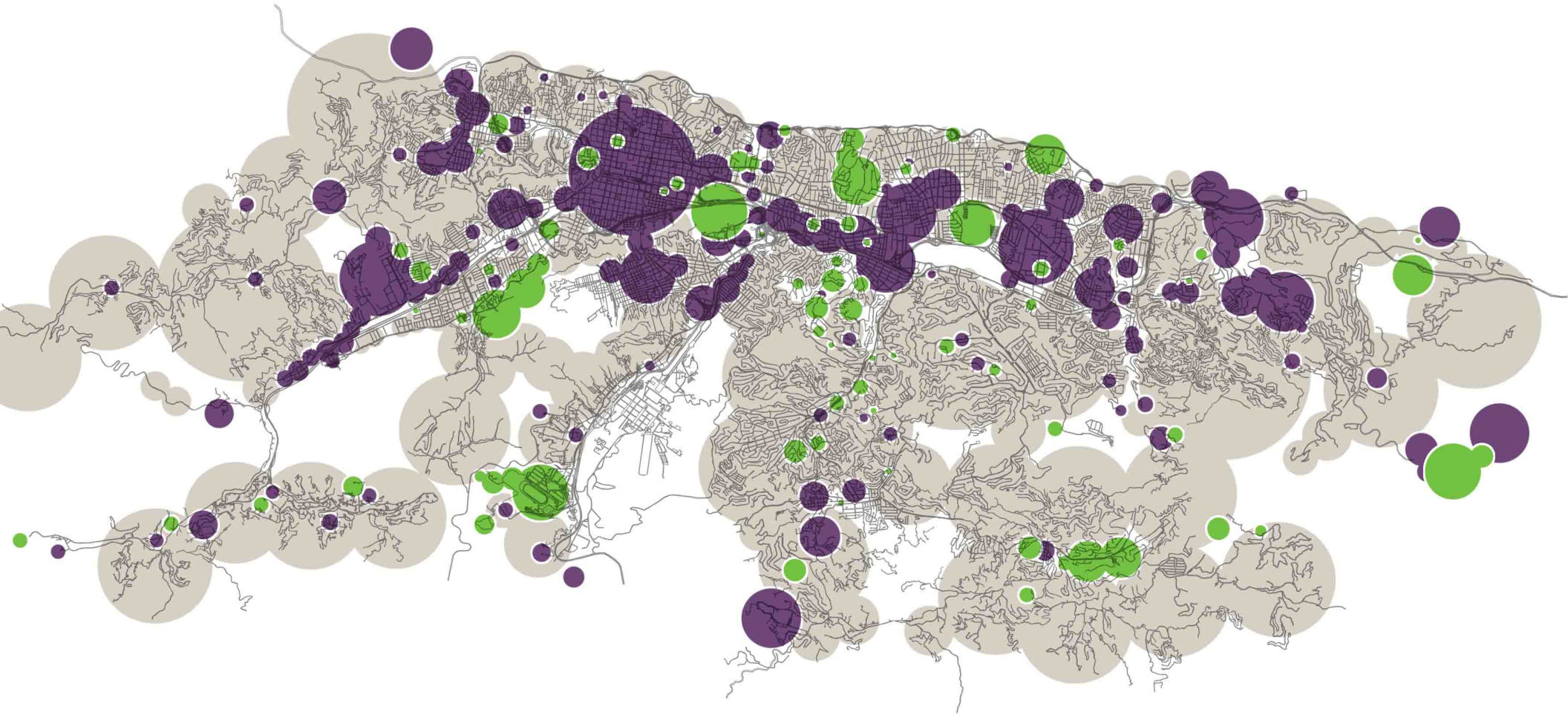



Enclave settlement

Border settlement



FORMAL VS. INFORMAL

The formal city is the one that develops under the supervision and control of the regulations and zoning statutes set by the authorities to ensure a degree of coherence in the ensemble, while the informal city develops spontaneously and illegally occupying the leftover areas around and within the city, creating enclave settlements with defined edges or border settlements that begin where the formal city ends and from there keep taking over the territory following no fixed pattern.

Informal settlements occupy 25% of the city and host 45% of its population. High density areas located as close as possible to the employment areas in order to reduce time and costs of transportation.

They start with unstable constructions made out of materials such as cardboard boxes, metal sheets, zinc sheets and wooden planks, mostly as demarcation of the area to be occupied.

When the dweller has integrated into the economy of the city, this fragile constructions begins to consolidate, replacing the materials for clay bricks, concrete and metal bars to put up walls, doors, windows and improving the roof in a slow process of continuous transformation.

The buildings adapt progressively to the needs of the dwellers by growing and being able to host other activities in order to increase the family income like a workshop, an extra room to rent, an improvised daycare, among others, creating a network of people and activities parallel to, and at the margin of the benefits and the responsibilities of the formal city, without an adequate access to basic service infrastructure, public space or public transportation.

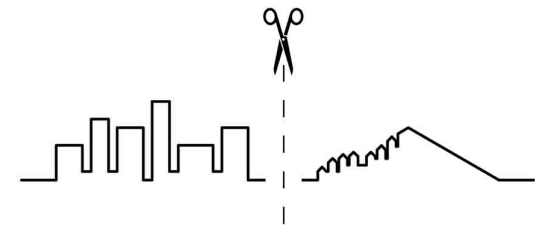



INFORMAL
SETTLEMENT



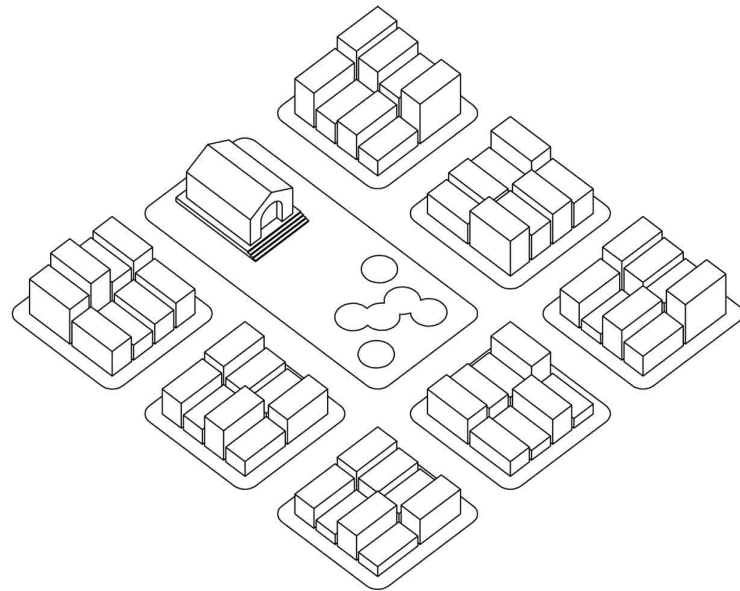

URBAN TYPES

COMPACT

Streets in an orthogonal grid configuration, with continuous buildings of one or two floors high and minimum setback on the sides. Mixed use that generates dynamic sidewalks and with a central open space where the social events take place and most of the time associated to public use buildings like a church or a cultural center.

Inherited from the traditional pattern as a Spanish colony and some of the early expansion of the city.

The example shows the historic quarter of Chacao and its Plaza Bolivar, similar to the historic quarters of Baruta, Petare and El Hatillo. The city center also belongs to this type, but nowadays with taller buildings, higher density, not only one but several open squares and associated with variety of churches, cultural buildings and headquarters of public authorities.



El Hatillo
Baruta

City center

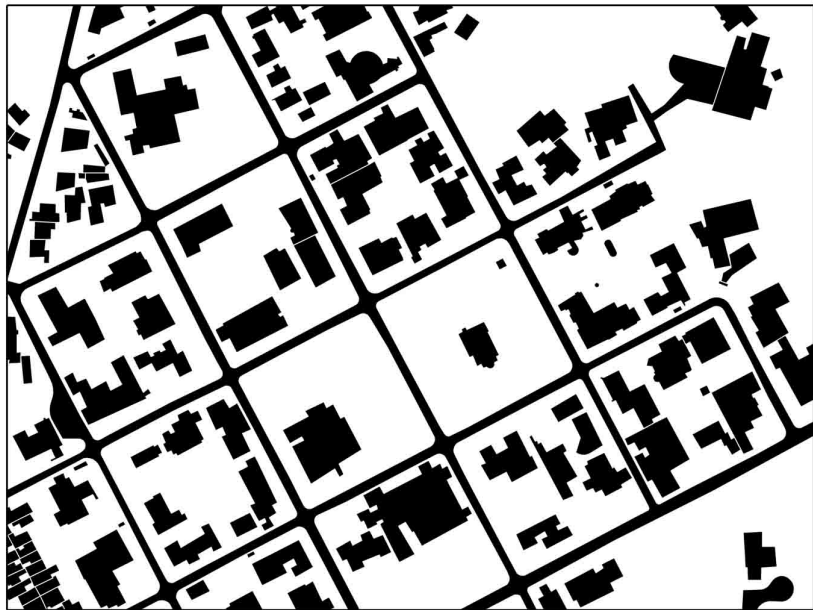
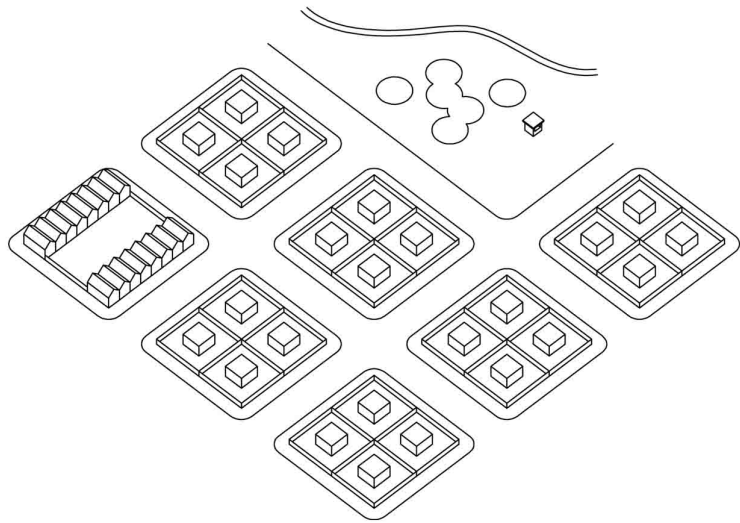

ISOLATED

Streets in a grid configuration, not always orthogonal, with buildings surrounded by gardens and large setback on all sides. No more that three floors high. Almost exclusively residential use and sometimes associated to an open public space, not very dynamic since the individual plots include their own private open space.

The first neighborhood of this type in the history of the city, El Paraiso, is nowadays a mix-use area with multi-family buildings and only some of the original garden villas remain.

The example shows the neighborhood Los Chorros and the recreational park with the same name, similar to the north area of the neighborhoods Los Palos Grandes, Altamira and La Castellana, the last two with a non-orthogonal streets grid, and the neighborhood Country Club.



Los Chorros
Los Palos Grandes

Country Club

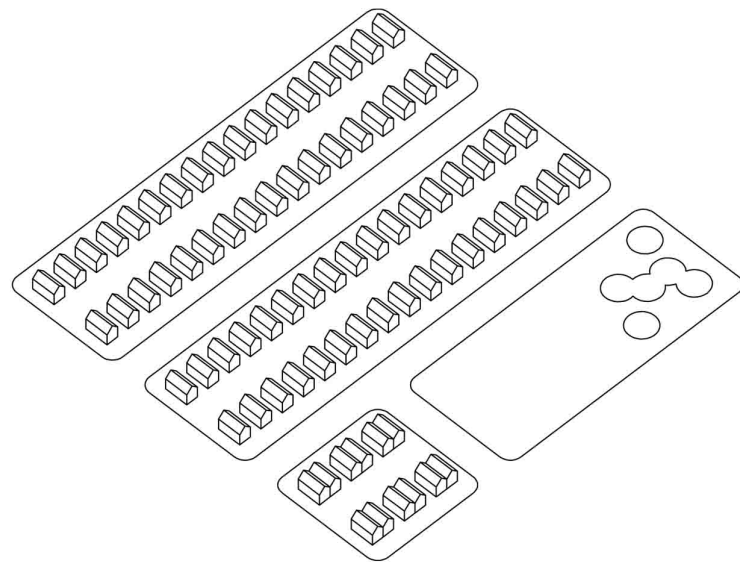

CONSECUTIVE

Streets in an elongated grid configuration, with buildings almost continuous in narrow plots with small setback on the sides and slightly larger setback on the front and the back. No more than three floors. Almost exclusively residential use and sometimes associated to an open public space, not very dynamic since the individual plots usually include their own private open space.

Attempts isolation of the entire ensemble and not only of the single plots by restricting the access to outsiders, leading to dead sidewalks that are nothing more than the entrance to the dwellings, generally done by car.

The exaple shows the neighborhood Colinas de Vista Alegre with the sports and recreational area of Parque Monagas, similar to the neighborhoods Vista Alegre, La California Norte and La California Sur.



La California Norte

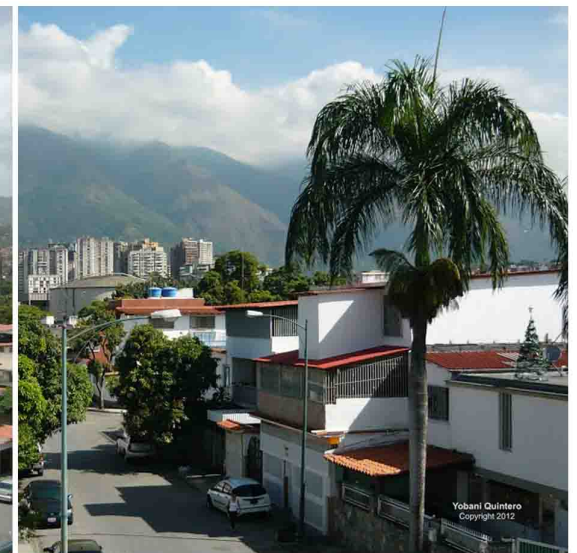

La California Sur

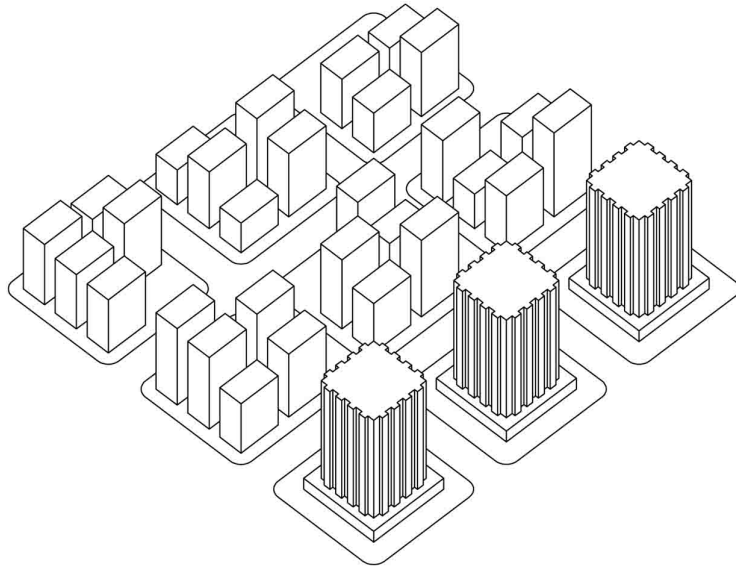

HIGH-RISE

Streets in an orthogonal grid with high-rise buildings and plots that increase in size and importance with the proximity of busy streets. Almost exclusively commercial and offices in bigger plots and mix-use on the others, with commercial on the ground floor and gradually increasing the residential use when moving away from the main street. Dynamic sidewalks.

The example shows the south area of the neighborhood Los Palos Grandes, part of the Francisco de Miranda avenue and the commercial buildings bordering the avenue: Parque Cristal office building, El Parque and Centro Plaza shopping malls, Seguros Qualitas headquarters and Hewlett-Packard headquarters.

Also along the same avenue and similar to this we find the south area of the neighborhood Altamira and the neighborhood El rosal. From the same type but along the Libertador avenue we find the neighborhoods of Sabana Grande and La Campina.

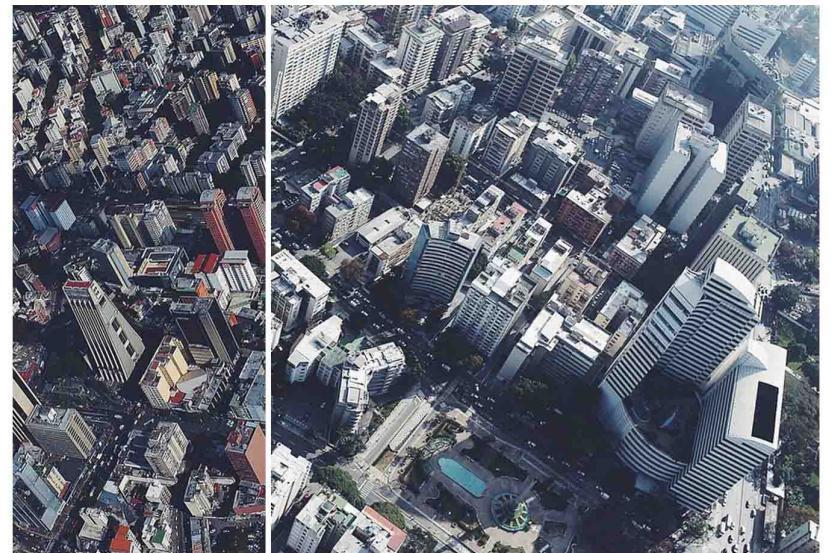

Sabana Grande
Plaza Venezuela

Los Palos Grandes
Altamira

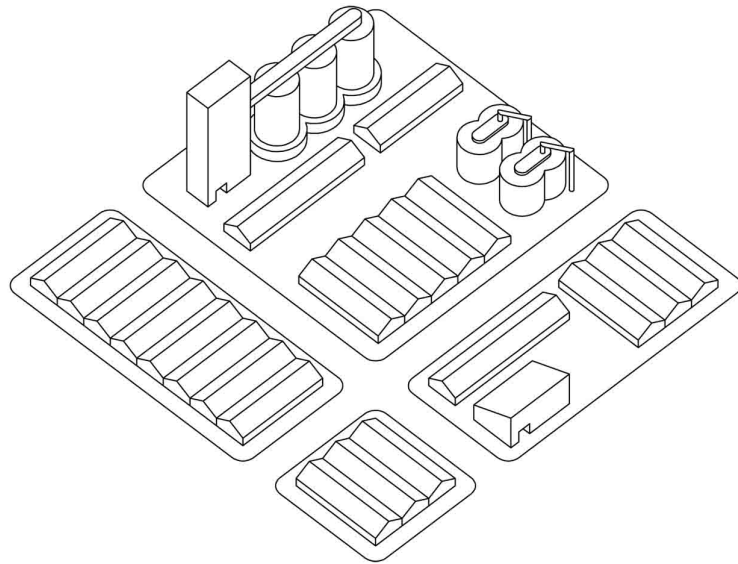

INDUSTRIAL

Streets in an irregular grid with large plots and low-rise industrial buildings and warehouses. The elements are organized inside the plot following the logics of the production processes and the nature of the company that occupies it, independent from what happens on the other plots. The use is almost exclusively related to manufacturing and commercial, with sidewalks that are dynamic only during working hours.

The example shows the industrial area in Los Cortijos to the north with buildings for Coca-Cola company, EPA hardware super store, Empresas Polar, and the industrial area in La California Sur, with DHL and FedEx headquarters and some more buildings for Empresas Polar.

Similar to this we find the industrial areas in Los Ruices, La Trinidad and Boleita with higher commercial activities and smaller industrial areas in Guaicay and Sector Las Nayas.



La Trinidad
Boleita

Los Cortijos

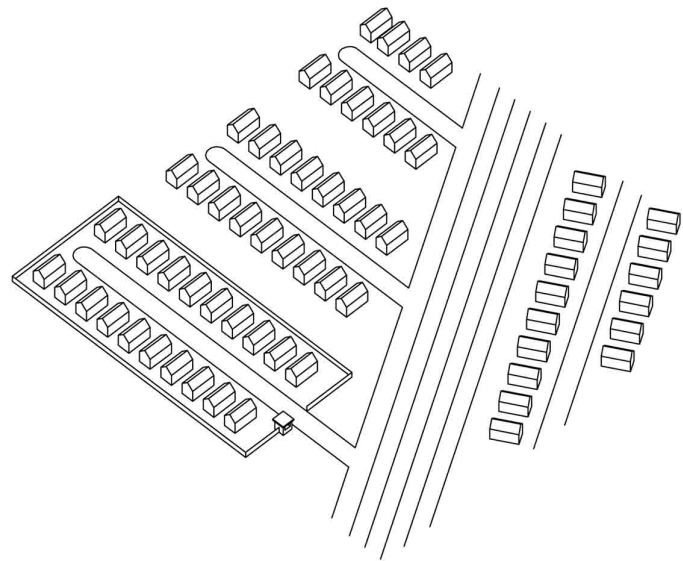

ORGANIC

Isolated buildings along streets that adapt to the topography following and organic line and allowing urban developments over the hills. Almost exclusively residential use and with dead sidewalks that are nothing more than access to housing, usually by car, associated with open areas not fitted for public use such as steep hillsides.

Buildings no more than three floors high in areas with single-family zoning and high-rise buildings instead in areas with multi-family zoning.

The example shows the neighborhood Caurimare, with single-family buildings, similar to the neighborhoods Cerro Verde, El Penon, Los Campitos and the multi-family buildings neighborhoods Valle Arriba, Manzanares and Loma del Sol.



Manzanares

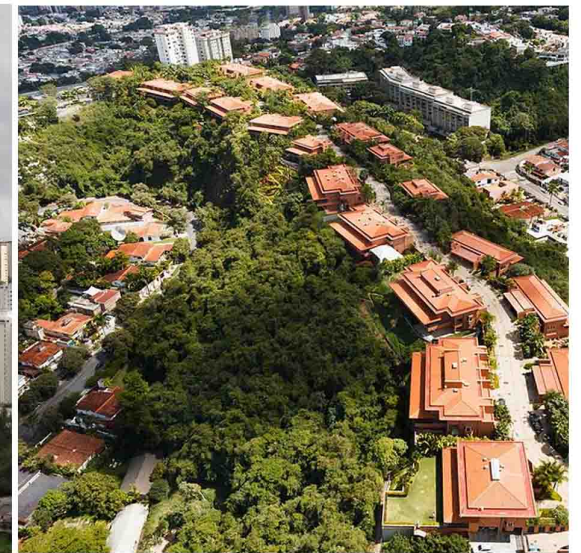

Caurimare

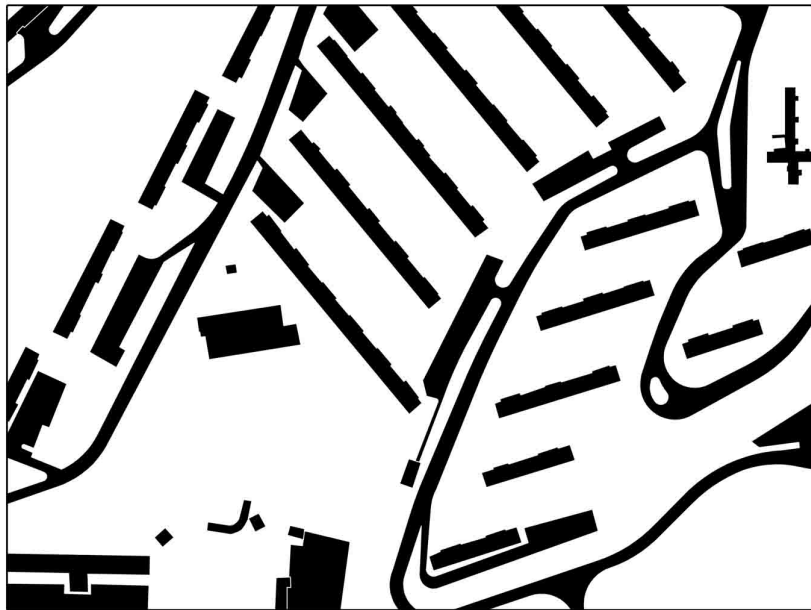
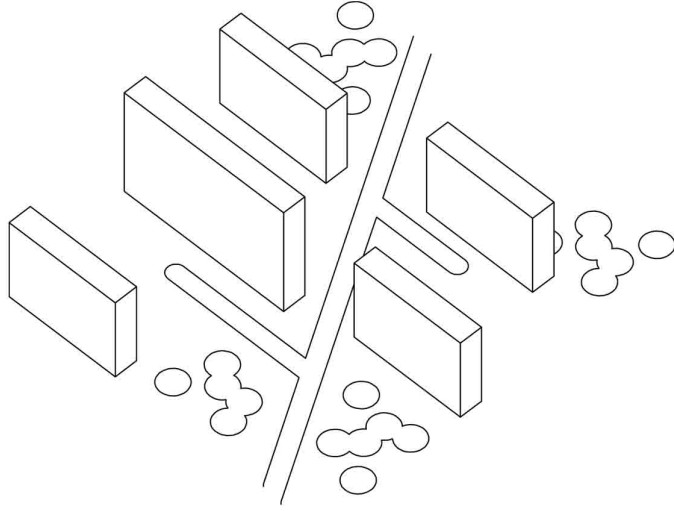

SUPER-BLOCK

High density and high-rise buildings arranged adapting to the topography of the hills, one apart from the other and accessible from organic streets that links them together in a single ensemble. Almost exclusively residential use with some services, vast parking space and recreational areas destined only to the residents of the complex. Dynamic sidewalks due to the large number of people and their socio-economic status, that is related to higher use of public transportation since most of them cannot afford a private vehicle.

The first super-blocks take as a direct reference the unite d'habitation of Le Corbusier, with services incorporated into them, that in later initiatives will be removed from the super-block and placed in separate smaller buildings.

The example shows the super-block neighborhood Propatria, similar to the ones in Simon Rodriguez, Ruiz Pineda and 23 de Enero.



23 de Enero



23 de Enero

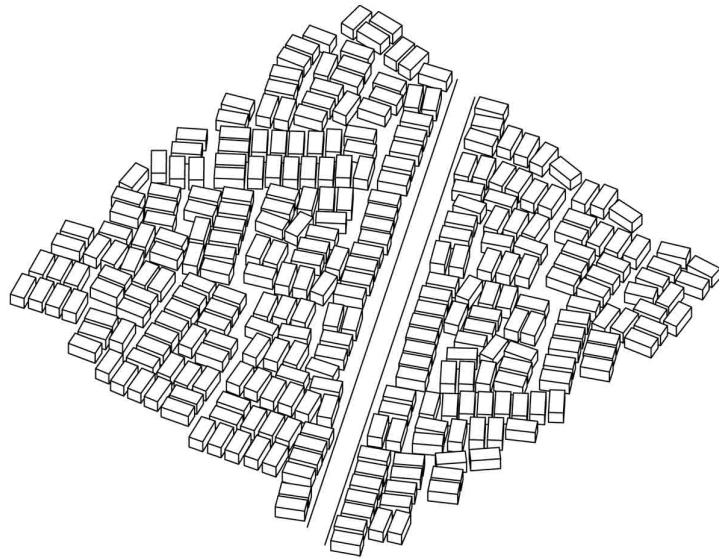

SPONTANEOUS

Self-made buildings arranged in a complex ensemble that adapts to the topography with no previous demarcation of streets, sometimes resulting in narrow passages or stairways only suitable for pedestrian use.

Mix-use area with commercial activities along the busy roads and small workshops or other small-scale activities combined with the residential in the same building. Dynamic sidewalks due to the large number of people, their socio-economic status, that is related to the fact that most of them cannot afford a private vehicle, and the large number of areas that can only be reached by foot.

The public space basically consist in the streets that cars, motorcycles and people share, and the leftover areas in between the buildings.

The example shows the informal settlement of La Cruz, similar to informal settlements of Mataadero, 5 de Julio, Jose Felix Rivas, El Mosquito and 12 de Octubre from the same sector, Petare.



Petare



Petare

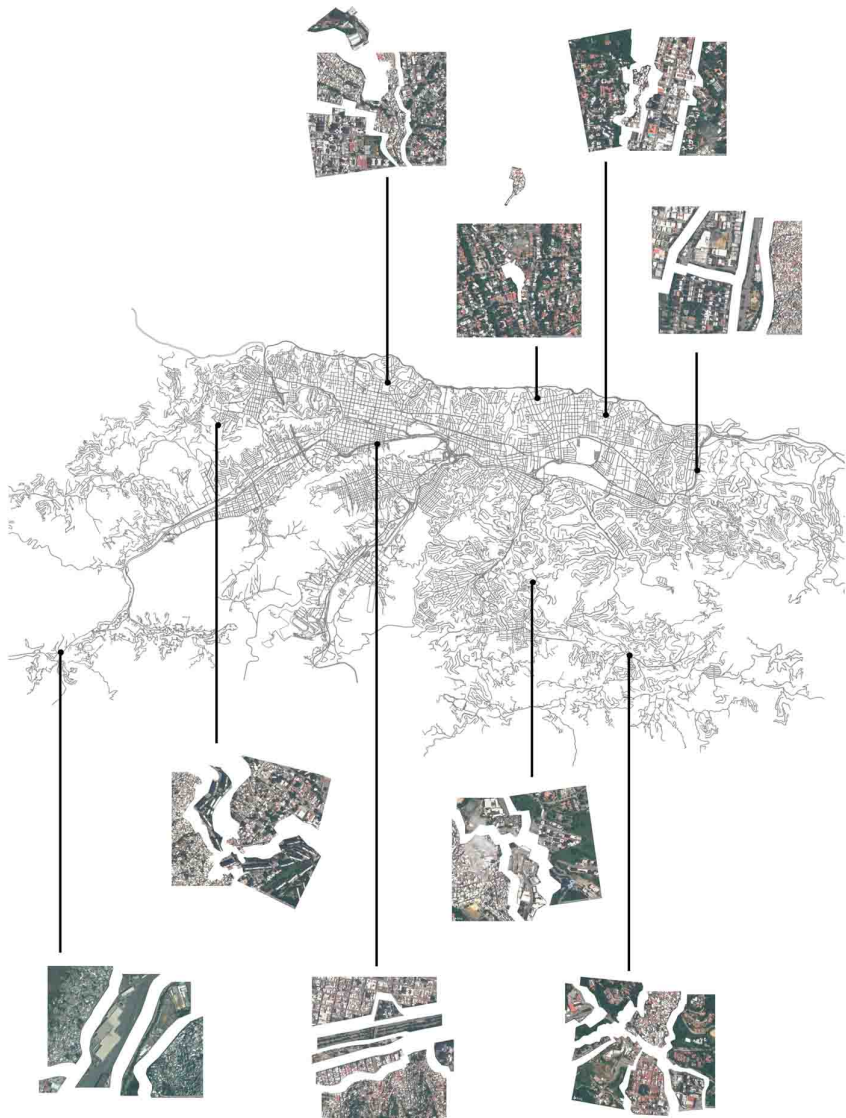

FRAGMENTS COLLISION

The city's most striking feature is diversity and contrast. Fragments with different characteristics in terms of density, use, socio-economic status of its inhabitants, street pattern among others, that trigger different situations whenever they are brought together.

Each fragment has its own positive and negative aspects that can be exploited or mitigated by the fragments nearby, according to how they integrate with each other.

Fragments are divided by physical or social barriers that can interfere with the exchanges and communication between them. Even a fragment in itself can become a barrier.

Sometimes the edges of these fragments are blurred and is difficult to identify where one ends and the other one begins, and sometimes the border is very clear. Several examples through the city where is possible to distinguish the collision of fragments from both the formal and the informal city are presented in the next pages.

Among the examples we will show an informal enclave surrounded by isolated villas; an ensemble of superblocks that separate a spontaneous development from a compact mix-use neighborhood or a small industrial area that divides a spontaneous development from a high-rise residential area; a mix-use street with commercial activities and high-rise residential buildings in between two neighborhoods of isolated villas; spontaneous developments along river streams; informal border settlements on the sides of a railway station infrastructure; several fragments that converge in the same point; and the informal and the formal city separated by a highway or by several barriers one after the other.

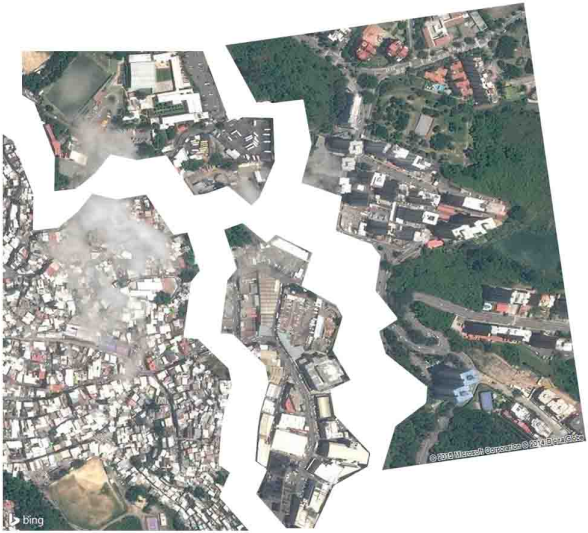
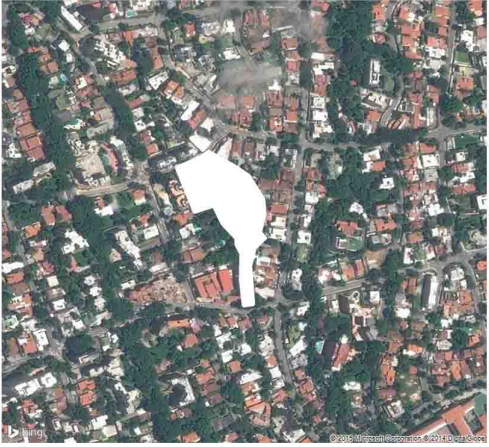

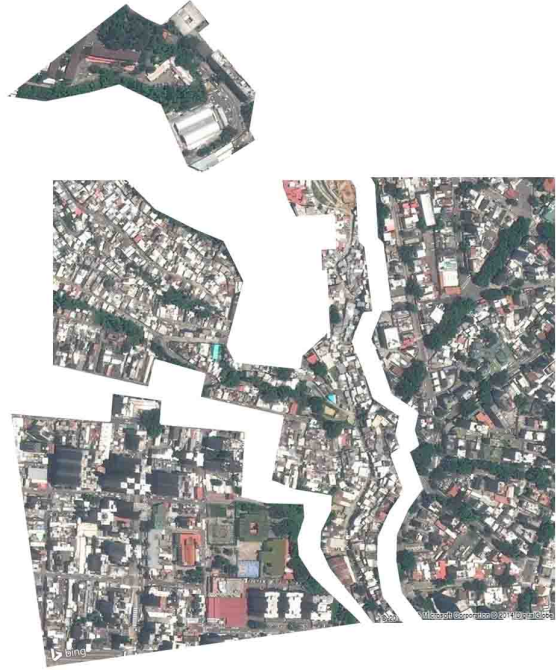



SAN AGUSTIN_PATCHING UP THE NEIGHBORHOOD

Patching: (verb) To mend a hole or garment by sewing patches on.

Patch: (noun) A piece of material sewn or applied to clothing, to cover a hole or reinforce a worn part.

In order to integrate the different city fragments in the sector of San Agustín we create a continuous layout of dynamic public space, mend the holes in the neighborhood by densifying and incorporating new programs to cope with the main problematics of the city: housing shortage, urban safety and lack of services.

The patch to be applied to the abandoned areas on the edge of the highway must include activities to motivate and attract the local people, favor the mobility by foot and by public transportation, to take advantage of proximity and mix-use, and as a consequence, reinforce the street life in the neighborhood, the inhabitant's identification with the place and a sense of belonging.

A local, human-scale and compact hybrid proposal that is permeable and accessible from the city, since it is the definition or completion of the urban pattern itself in its leftover areas.

Individual programs that relate to one another, share intensities, overlapping users and working hours, nonstop activities to generate a continuous flow of people and spontaneous surveillance without the need of authorities to control during the vulnerable hours of each program, inclusion of housing to provide friendly lights on the street during night, job opportunities and services to satisfy the requirements of the community, and the outsiders.

Fixed, seasonal and spontaneous situations. Meeting places where to walk, take the children out to play, practice sports, sit down or wait for the bus, taking into consideration the uses on its borders, the urban elements that shape the place, visibility from the surrounding areas and the general feeling of safety.

Ultimately, enhance the image of the neighborhood for residents, visitors and investors, increase the quantity and quality of the public space to facilitate commercial and social encounters, integrate different realities of the city and set an example of inclusion for the other fragments collision through the city.

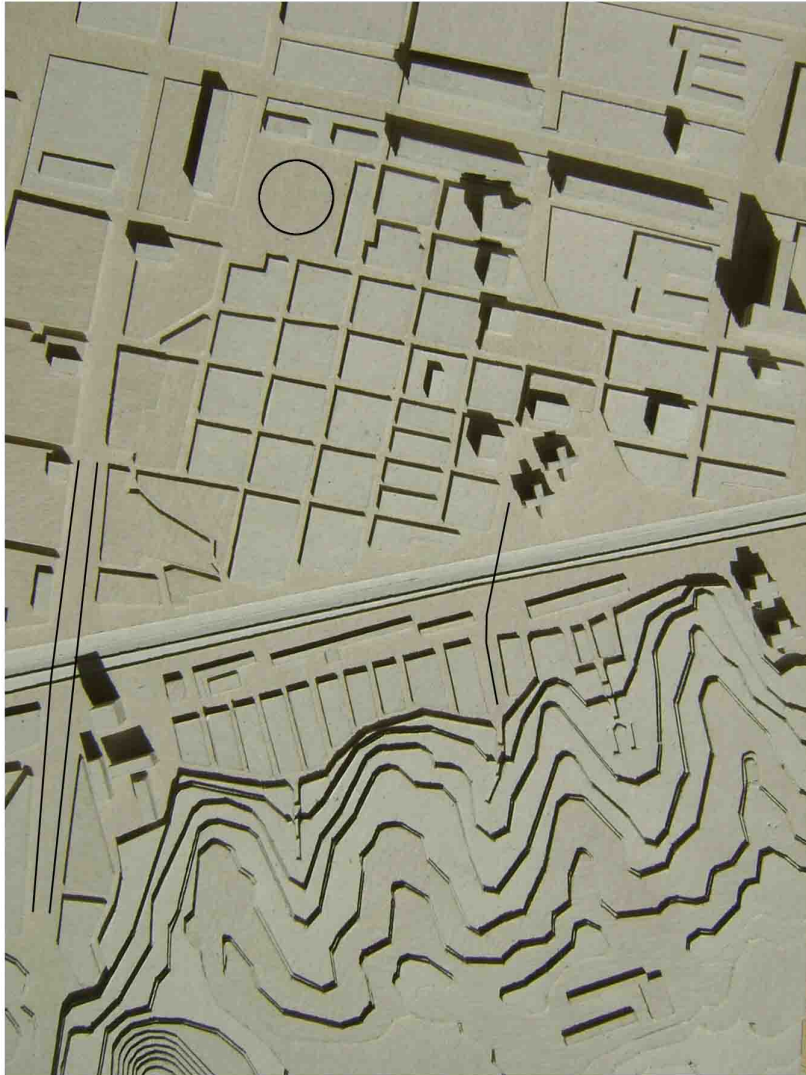

THE PLACE

From north to south.

The Avenida Bolivar, product of the realization of the Plan Rotival from 1936, a large-scale urban project for the development of the city center, and public buildings to its sides like the Nuevo Circo bull ring, Carlos Cruz Diez museum, MUSARQ museum, a municipal market, Galeria de Arte Nacional and the Parque Central complex.

Mision Vivienda social housing initiative that begins in 2011, inserted along the avenue as residential blocks in the previous green area of Parques Vargas.

Urban development that follows the street pattern of the city center with smaller modules and compact buildings, built between 1926 and 1928, originally destined to middle class housing on the north, high income villas to the east after the Catuche river stream, and low income housing to the south after the Guaire river.

The southern edge of San Agustin Norte is not uniformly defined since demolitions had to be done to allow the construction of the Francisco Fajardo highway 1964, now empty abandoned areas or filled with warehouses and parking lots.

On the other side of the river was planned in the 80's a project for urban renovation of the neighborhood, with services and public space along the Leonardo Ruiz Pineda boulevard that aimed to a positive transformation of this area of the city, already dense at the time thanks to the addition of a few high-rise residential towers and in the proximity of the informal settlement of El Mamon, El Progreso, El Manguito, La Ceiba, Marin, Homos de Cal and La Charneca.

Nowadays only some parts of this proposal are working, like the church and the public library.

Two bridge connections over the highway and the river, both of them with double-way roads and pedestrian sidewalks accessible only from the endings of the bridge.

There is also the MetroCable, a unique element of the public transportation system with suspended carts that connect the Leonardo Ruiz Pineda boulevard with the Metro station in Parque Central complex and with three intermediate stops in the upper part of the informal settlements on the hill.

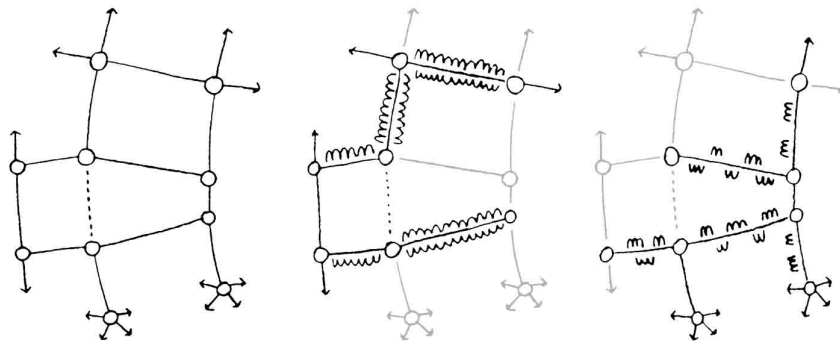
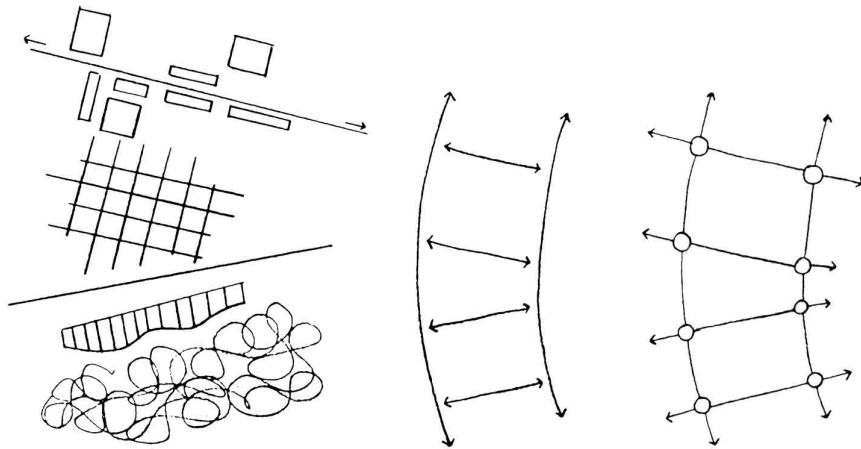

THE STRATEGY

To create a network of public spaces to integrate the different fragments in the neighborhood, from the Avenida Bolivar to the informal settlements of San Agustin, making use of the street pattern, the existing bridges and the few existing public squares and open areas as well as some specific buildings to be transformed into public space or other use.

To reshape and define the edges of the highway, making use of the leftover areas, abandoned buildings and some specific warehouses in order to densify the border along the border and provide new services as well as employment and housing opportunities for the local community.

The aim of these strategies is to revitalize a neighborhood that has a large number of inhabitants, not enough services, not enough public space and attract people to the edge of the highway which is generally the area that lacks street life the most, and as a consequence very unsafe.

Once the neighborhood increases the quality of its street life, is possible to take advantage of the historic image and its proximity to the city center, museums and important public buildings to attract tourists or outsiders, resulting in more diversity and bringing even more life to the area.

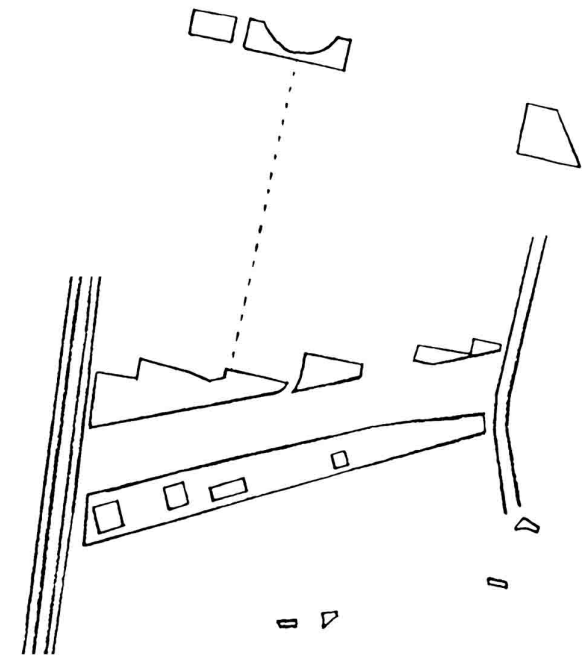

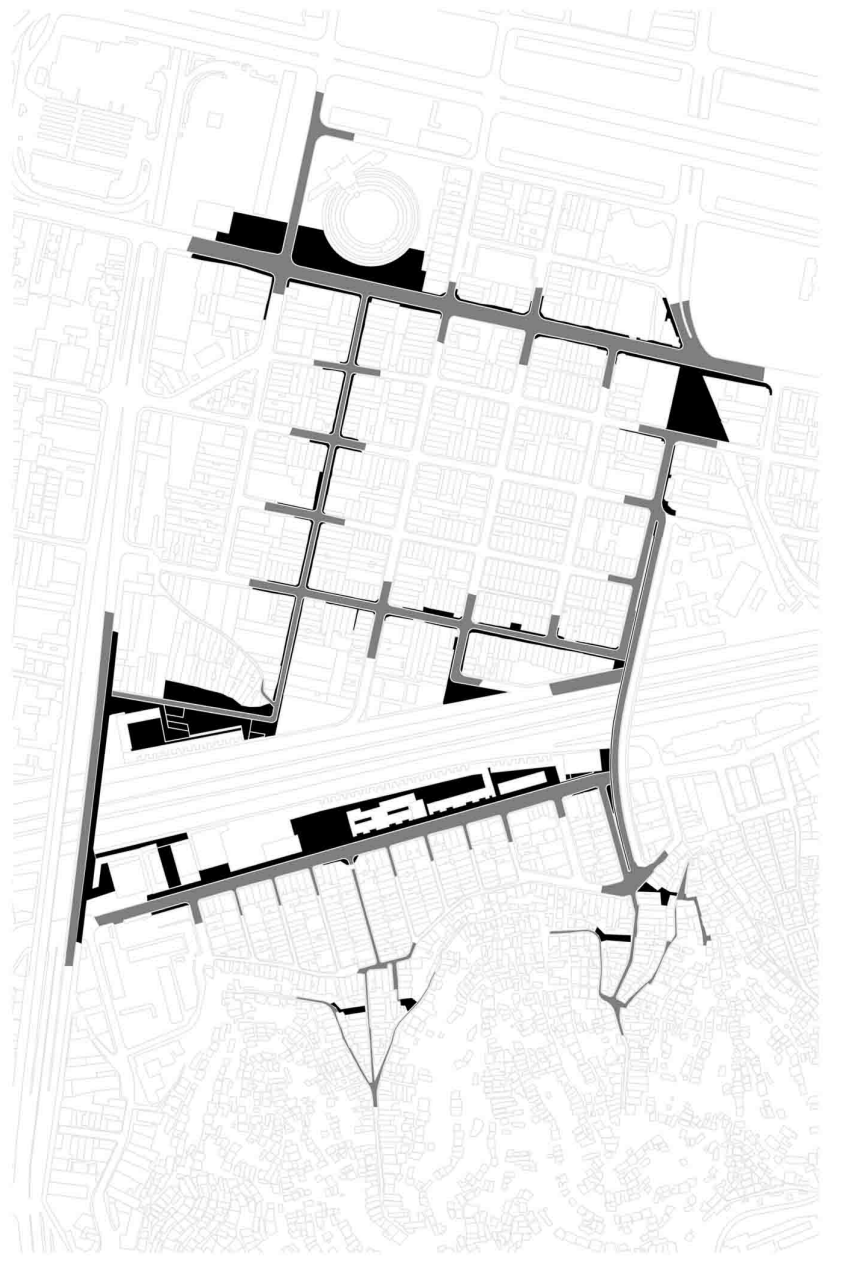

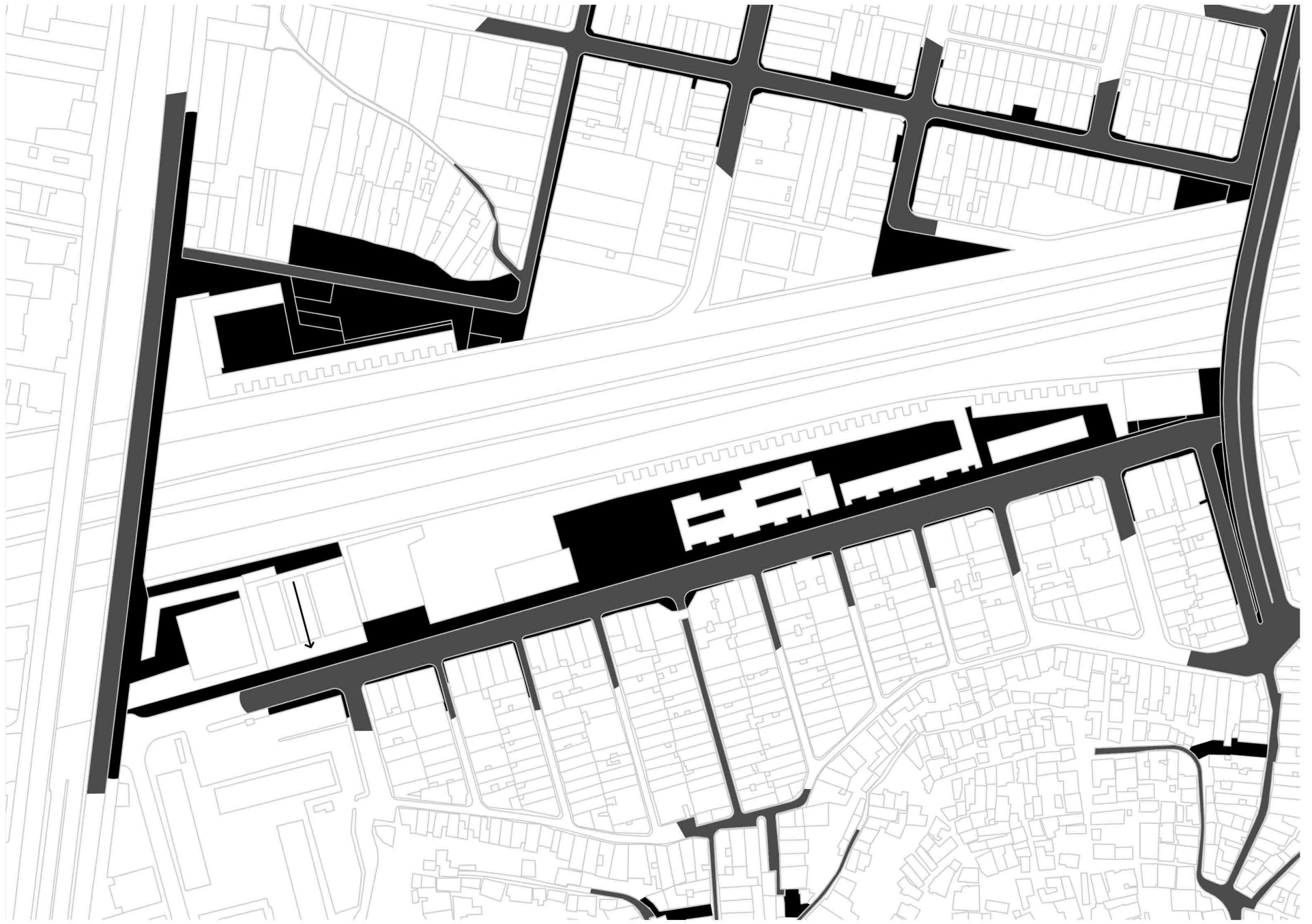

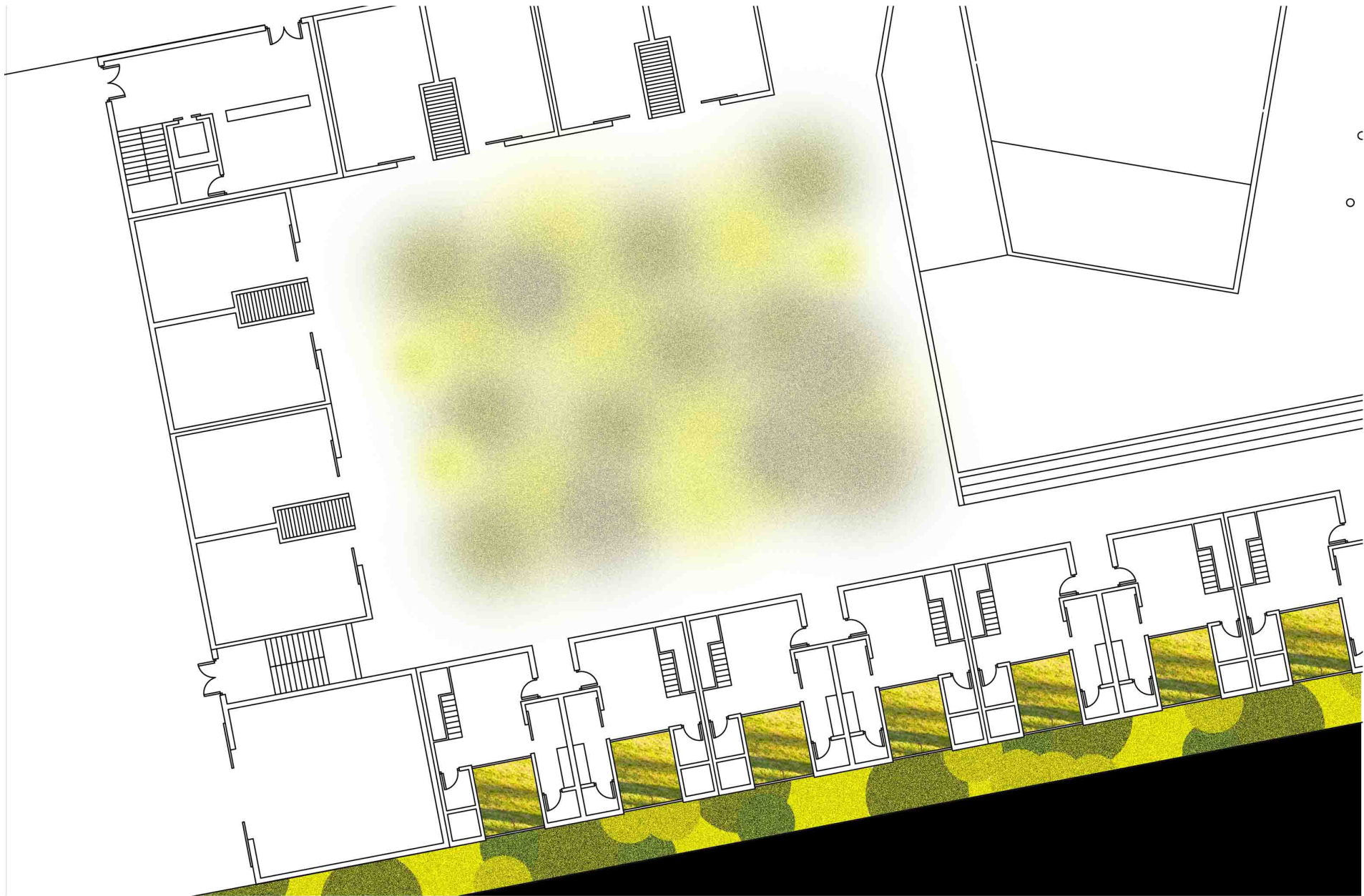

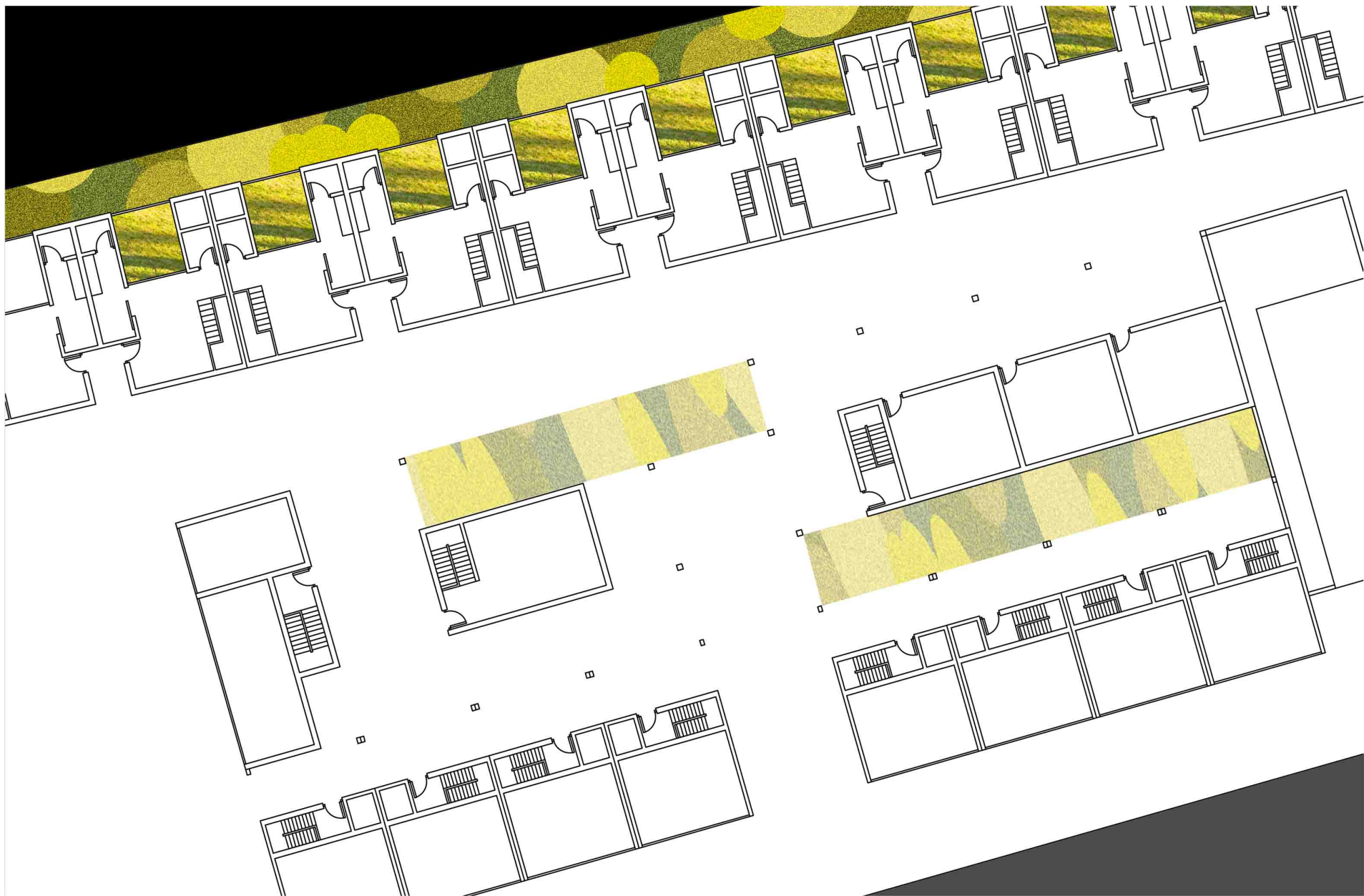

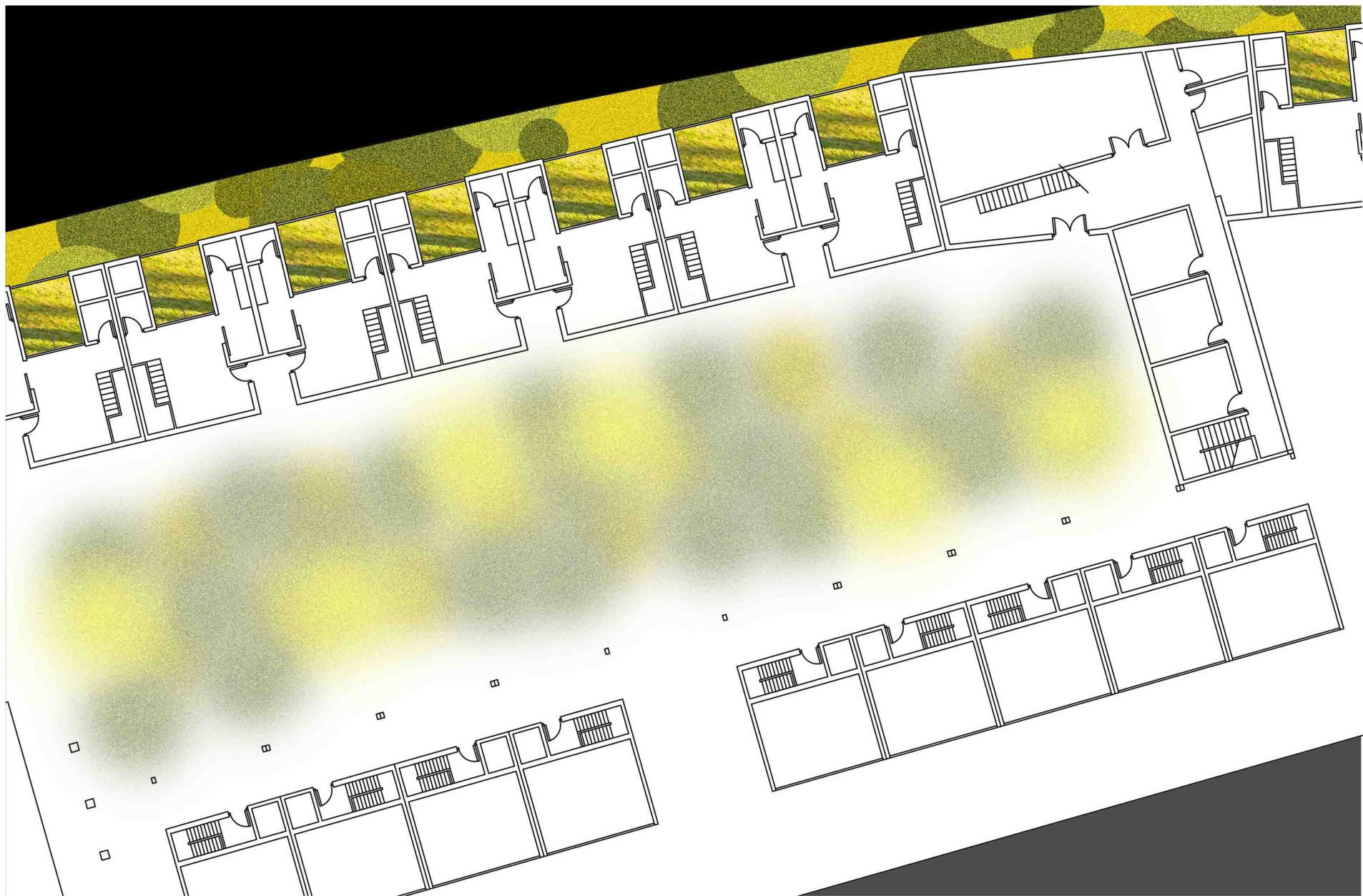



BIBLIOGRAPHY

Consulted books

GAZPARINI, Graziano & POSANI, Juan Pablo. Caracas a través de su arquitectura.
LOPEZ VILLA, Manuel Antonio. Arquitectura e historia_ Curso de historia de la arquitectura v. II
Urban Think Tank. Torre David_ Informal vertical communities.
LERUP, Lars & Studio Sputnik. Snooze_ Immersing architecture in mass culture.
a+t research group & FERNANDEZ, Aurora & MOZAS, Javier & ARPA, Javier. This is Hybrid_ An analysis of mix-use buildings.
ROGERS, Richard. Citta per un piccolo pianeta.
KOOLHAAS, Rem. Delirious New York.
JACOBS, Jane. The death and life of great American cities.
TIESDELL, Steven. Revitalizing historic urban quarters.
ARAVENA, Alejandro & IACOBELLI, Andres. Elemental_ Incremental housing and participatory design manual.
MELOTTO, Bruno & PIERINI, Orsina Simona. Housing Primer_ Le forme della residenza nella città contemporanea.

Consulted online papers

(2012) Alcaldía Metropolitana de Caracas. Avances del Plan Estratégico Caracas Metropolitana 2020.
(2001) DE LISIO, Antonio. La evolución urbana de caracas_ Indicadores e interpretaciones sobre el desarrollo de la interrelación ciudad-naturaleza.
(2011) COLMENARES, Geiza. Transición de la vivienda rural a la vivienda urbana durante la dictadura de Marcos Pérez Jiménez.
(2010) REBOTIER, Julien. Planificación, gobernanza y vivienda en la Caracas democrática_ Contextualizar para comparar.
(2005) MEZA, Beatriz. Proyectos del taller de arquitectura de Banco Obrero TABO para el plan nacional de vivienda en Venezuela 1951-1955
(2008) MEZA, Beatriz. Superbloques y masificación_ Vivienda Banco Obrero en Venezuela 1955-1957.
(1971) URQUIJO, José. Los Barrios de Caracas.
(2010) MARTÍNEZ, José Antonio. La política petrolera del gobierno Chávez_ La redefinición del estado ante la globalización neoliberal.
(2004) RAUSEO, Newton. Gestión urbana estatal en la parroquia San Agustín de Caracas_ Caso Centro Simón Bolívar C.A.
(2010) RIVA, Nicolo. Evolution of contemporary living towards heterogeneity and networks of individualities.

Consulted online blogs

caracas-antesahora.blogspot.it/2008/03/evolucin-histrica-de-caracas.html
icomosdevenezuela.blogspot.it/2013/07/patrimonio-edificado-de-la-venezuela_6.html
oscartenreiro.com/2013/12/21/una-pequena-historia-necesaria/
mediodigitalfau.blogspot.it/2011/12/banco-obrero-en-venezuela-mediados-del.html
sanagustindelsur.blogspot.it

