

the Industrial Revolution

the division of builders and users

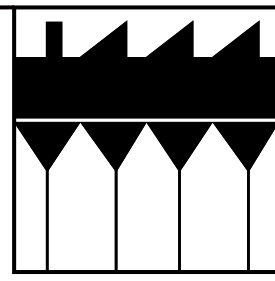

emergence of collective living

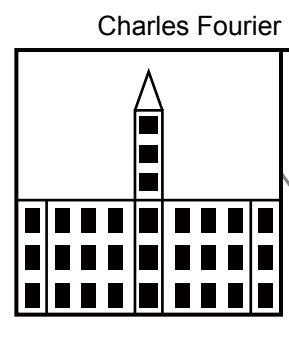

Charles Fourier

Phalanstery 1822

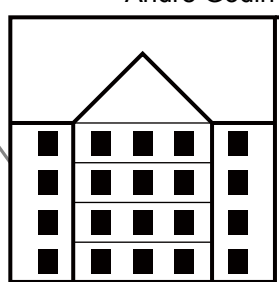

André Godin

Familistère 1856

Peter Behrens

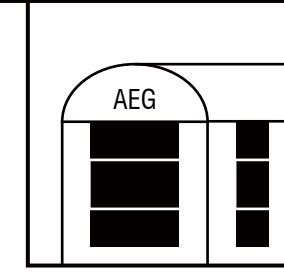

Deutsche Werkbund

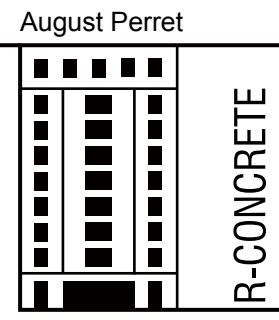

August Perret

25 Rue Franklin 1902-1904

1910-1911

1908-1909

1908-1912

1908-1910

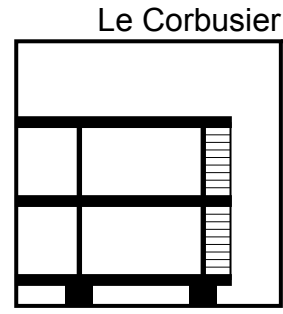

Dom-ino 1914-1915

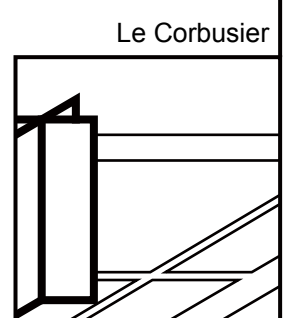

Ville Contemporaine 1922

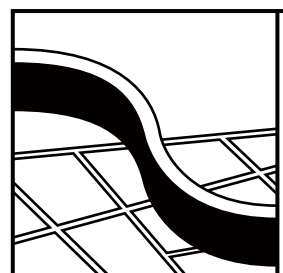

City Plan Obus 1933

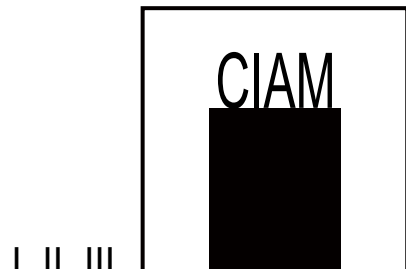

I, II, III

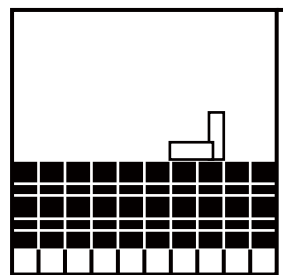

Unité d'Habitation 1947-1952

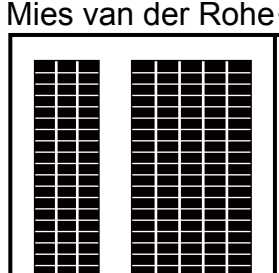

Lake Shore Drive Apartment 1949

the Second World War (end)

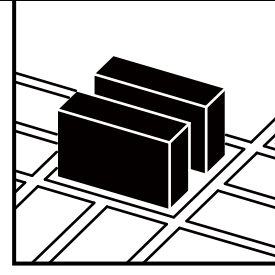

Urban Renewal

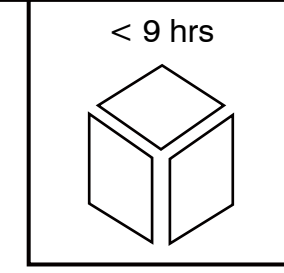

Packaged House 1941-1952

< 9 hrs

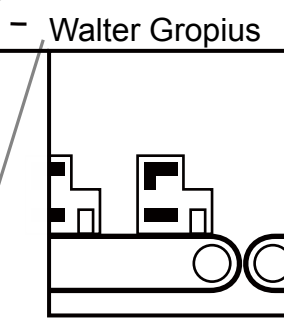

Minimum Dwelling 1929

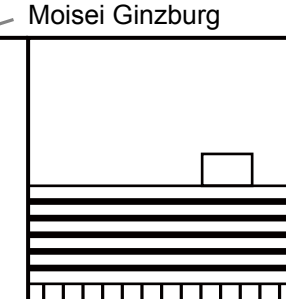

Narkomfin Building 1928-1930

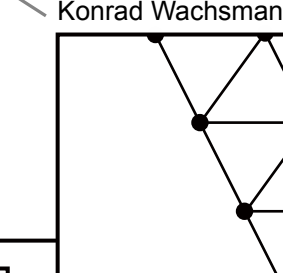

Space Frame 1951

Konrad Wachsmann

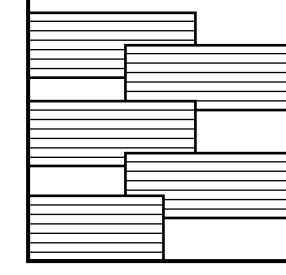

Public Housing in the USSR

the Consumer Society

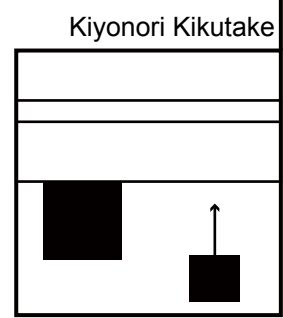

Sky House 1958

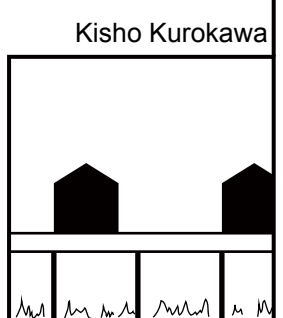

Agriculture City 1960

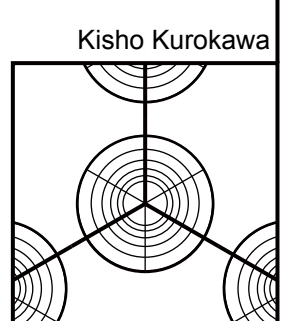

Helix City 1961

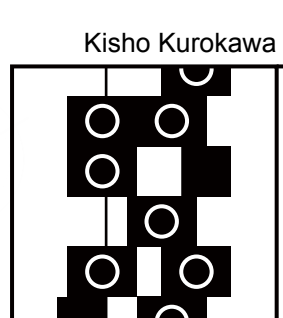

Nakagin Tower 1970-1972

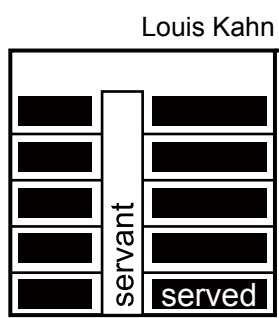

Served and Servant Spaces 1965

Louis Kahn

servant served

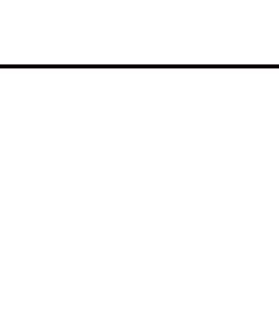

Stratiform Structure Module 1972

Kiyonori Kikutake

train cars

Richard Rogers

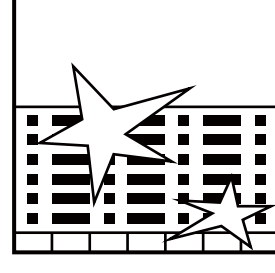

Pruitt-Igoe Explosion 1972

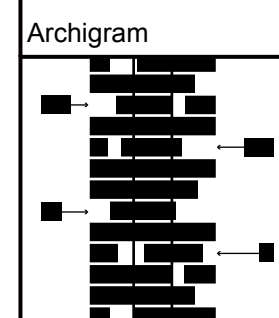

Plug-In City 1960-1974

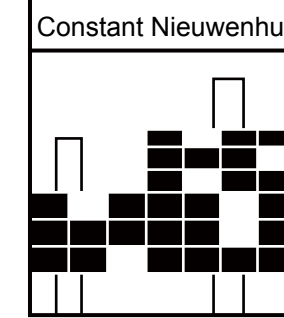

New Babylon 1959-1974

Constant Nieuwenhuys

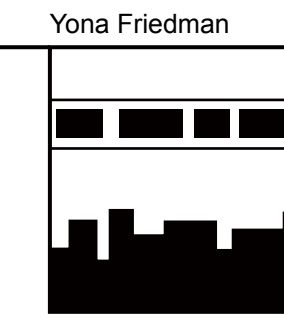

Spatial City 1958-1959

Yona Friedman

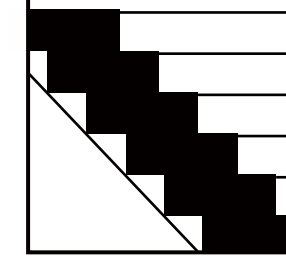

Golden Mile Complex 1973

Tay Kheng Soon

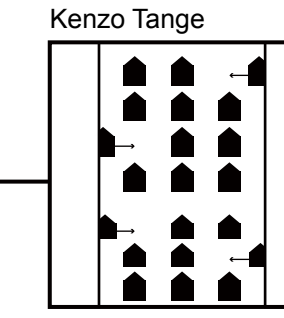

Temporary Hajj Village 1974

Kenzo Tange

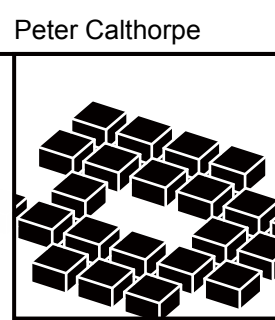

New Urbanism

Peter Calthorpe

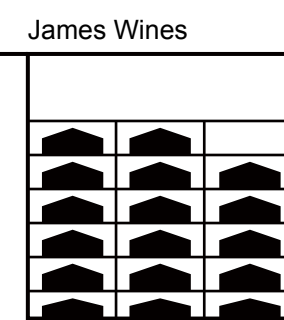

High Rise of Homes 1981

James Wines

the speeding-up Globalization



Chinese Urbanization Frenzy

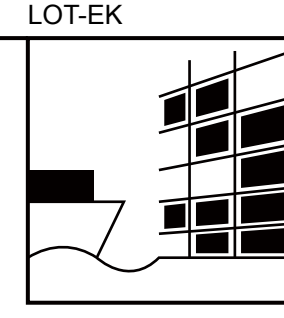

Modular Dwelling Unit 2003

LOT-EK

where we are

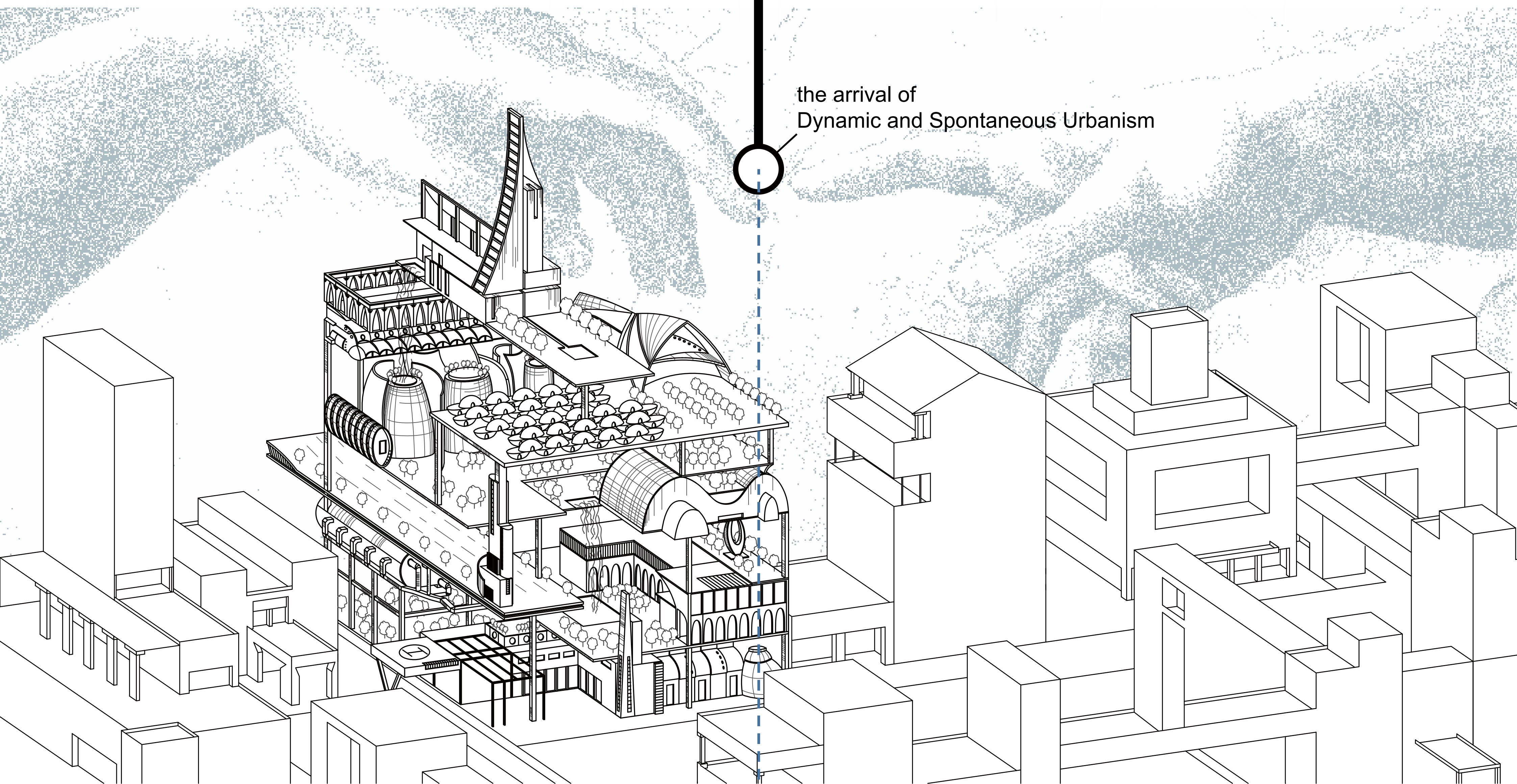
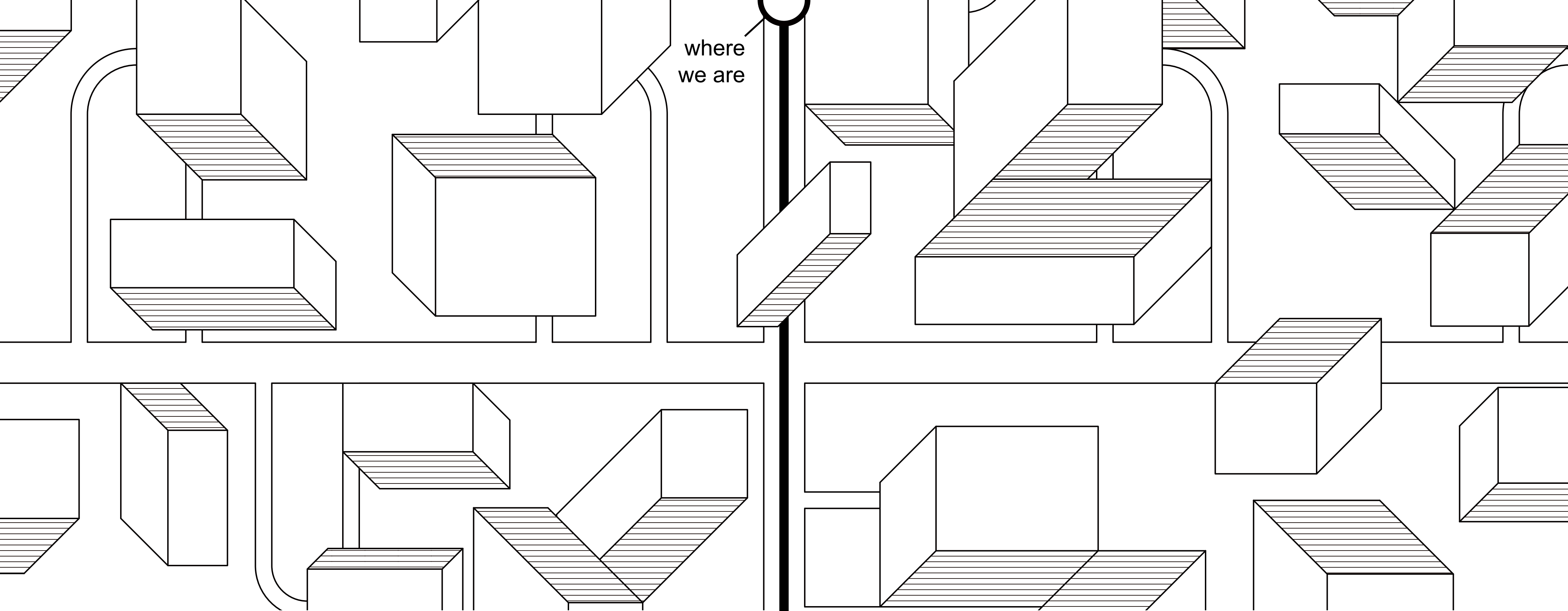

the **M**odular **I**ndustrialized **A**rchitecture

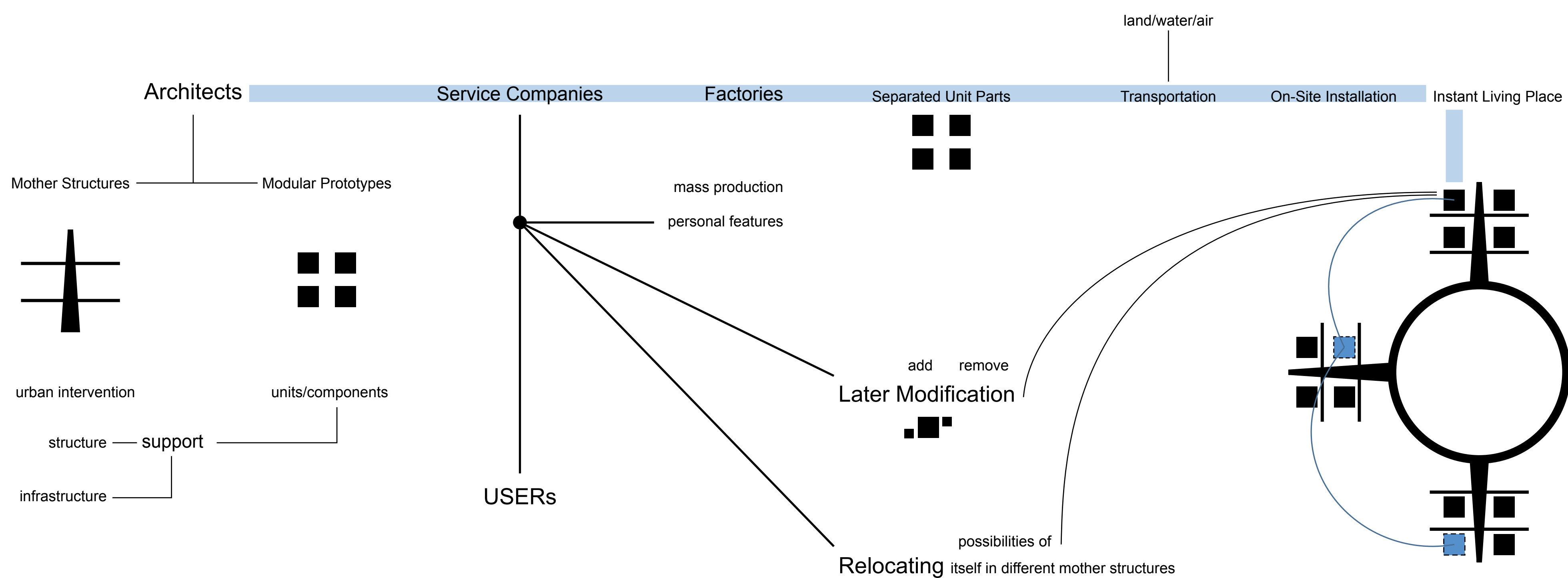

Project SHANGHAI

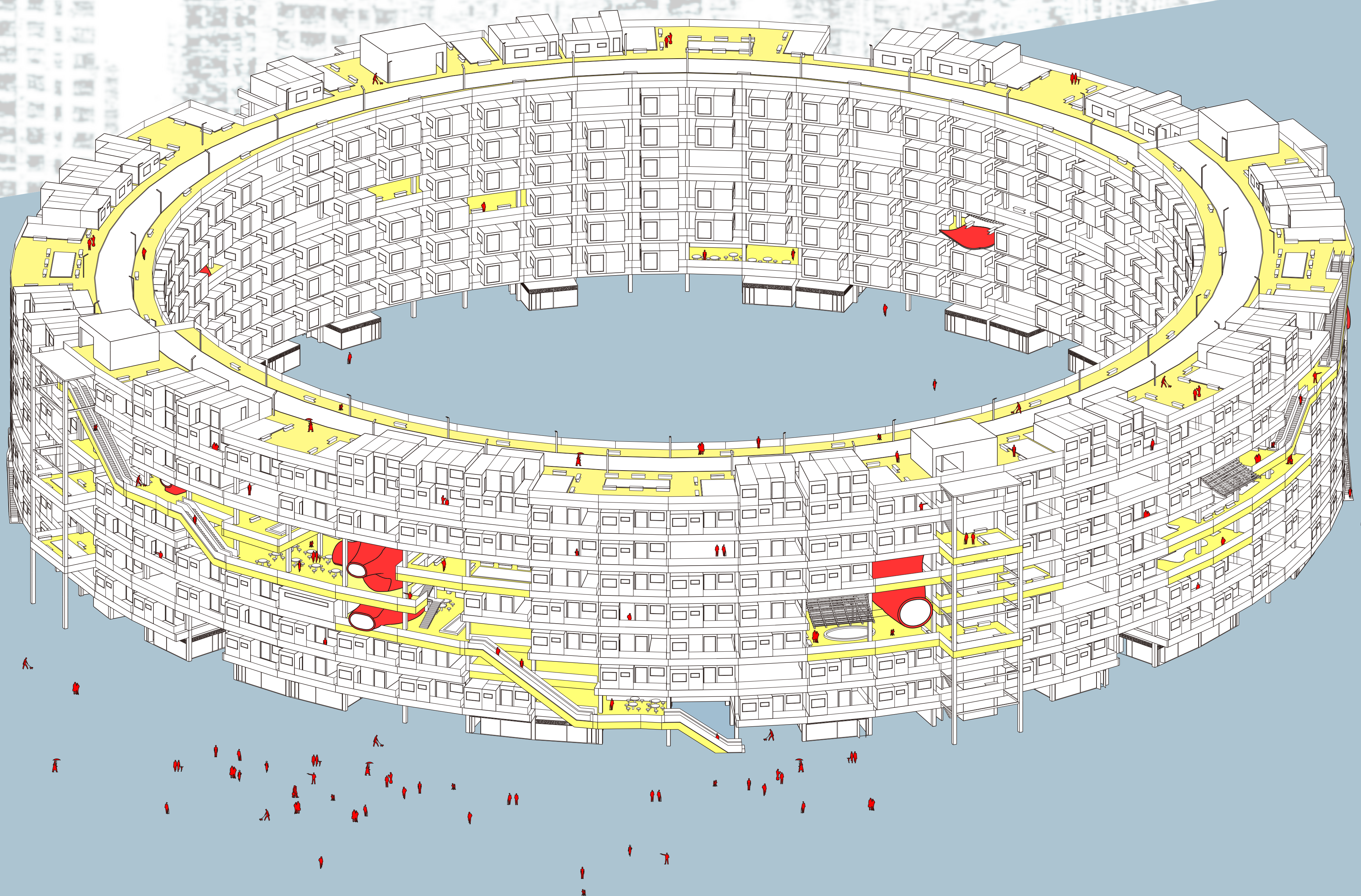

Concept

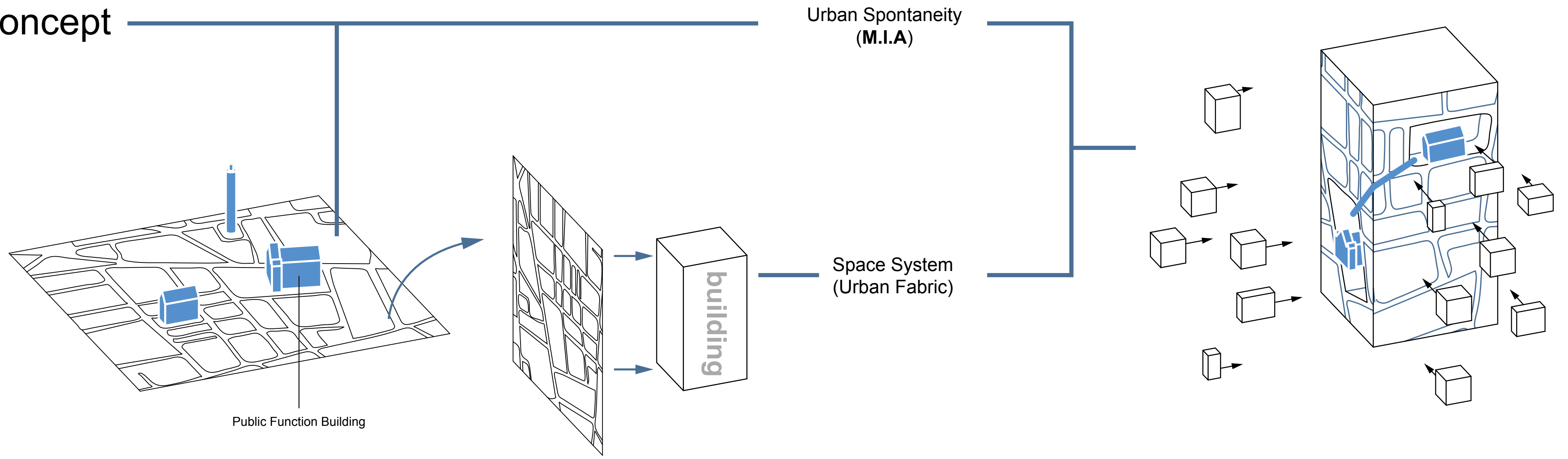

Morphogenesis

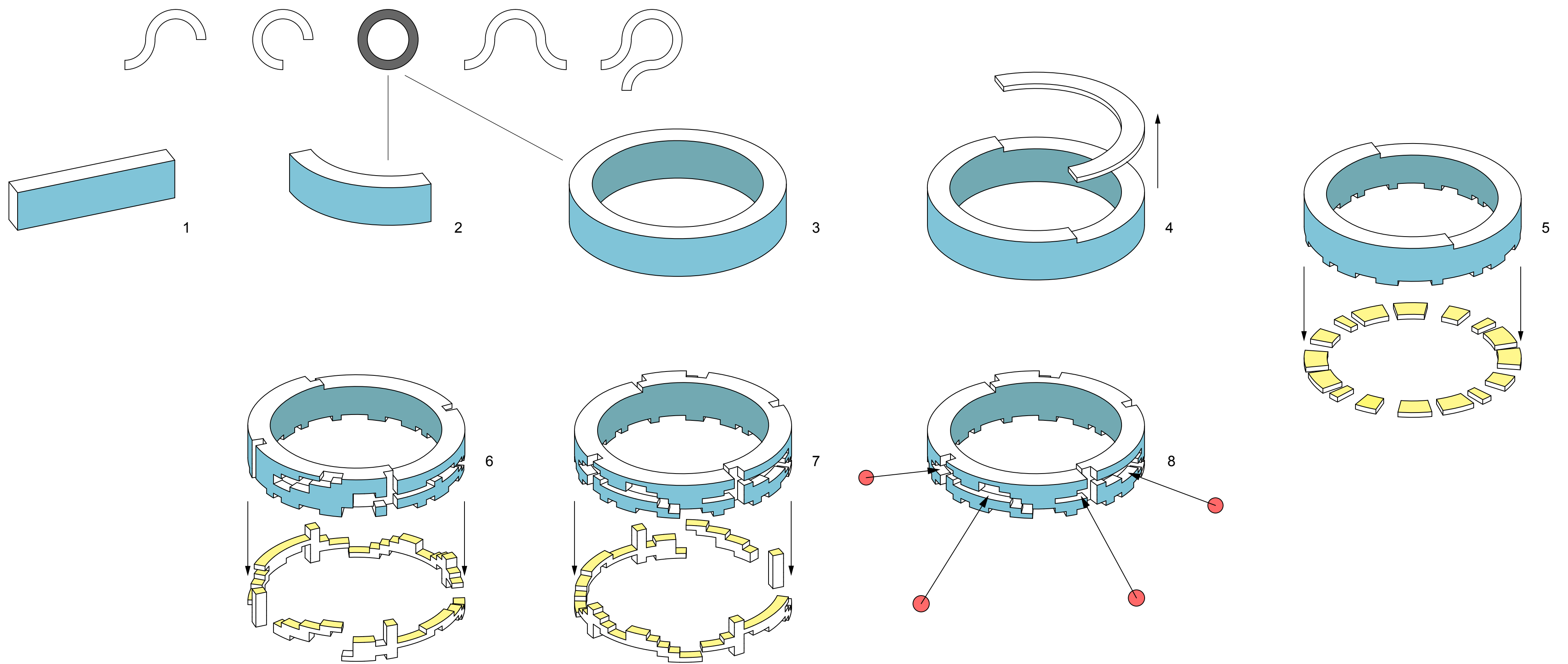

A Dynamic Living System

the simulation of area population change

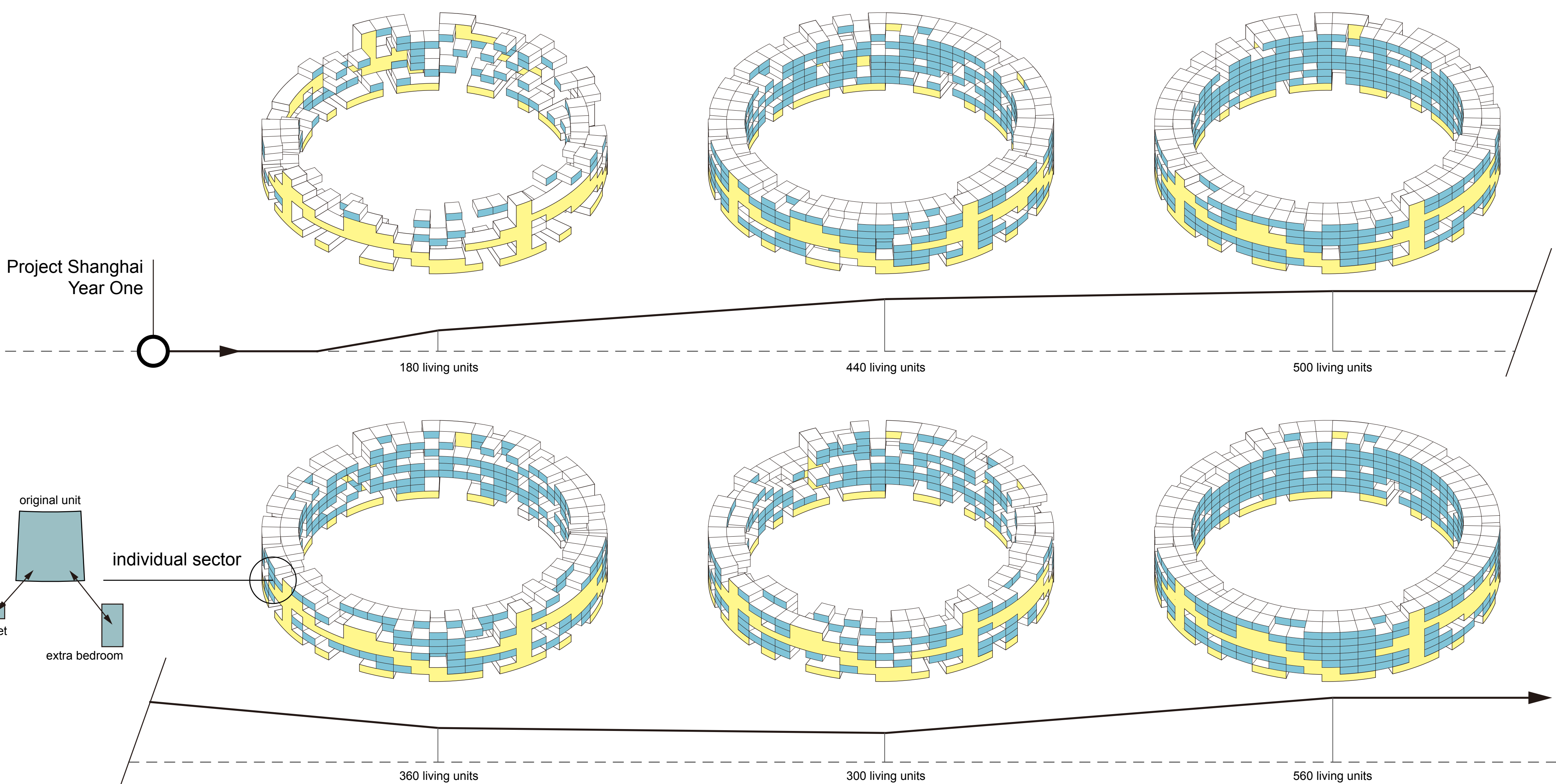

Continuous Public System

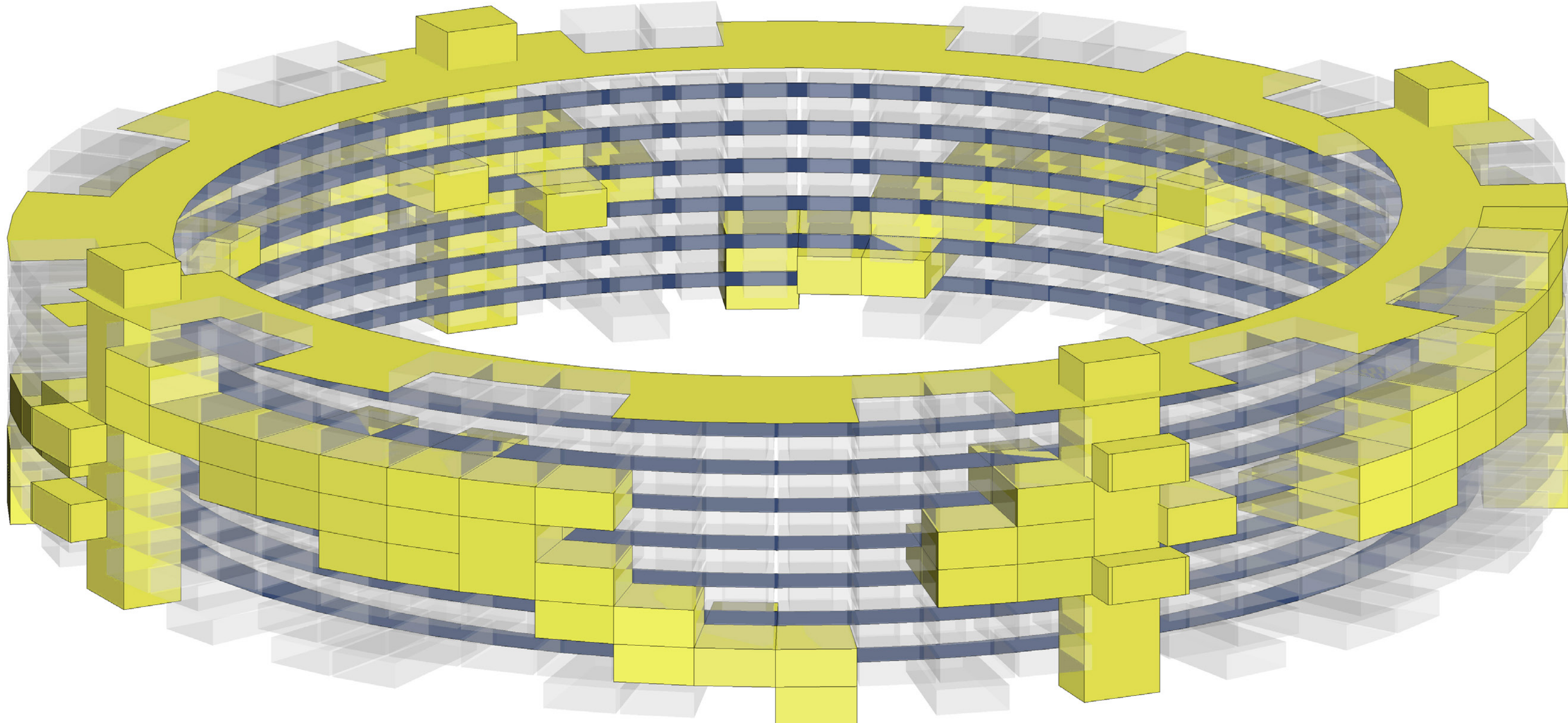

main public space

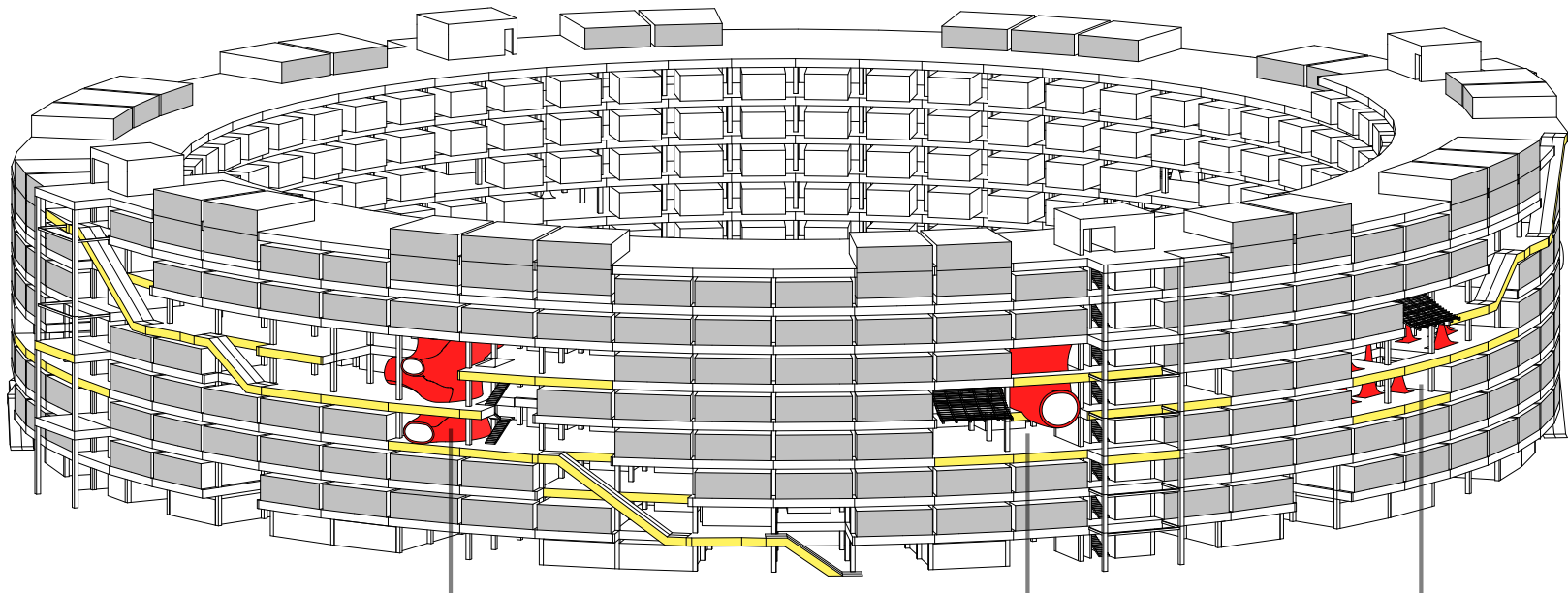
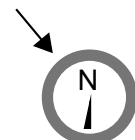

restaurant area cafe area mountain garden area

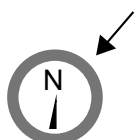

exhibition area: 2D/medias arts exhibition area: sculptures/installations restaurant area

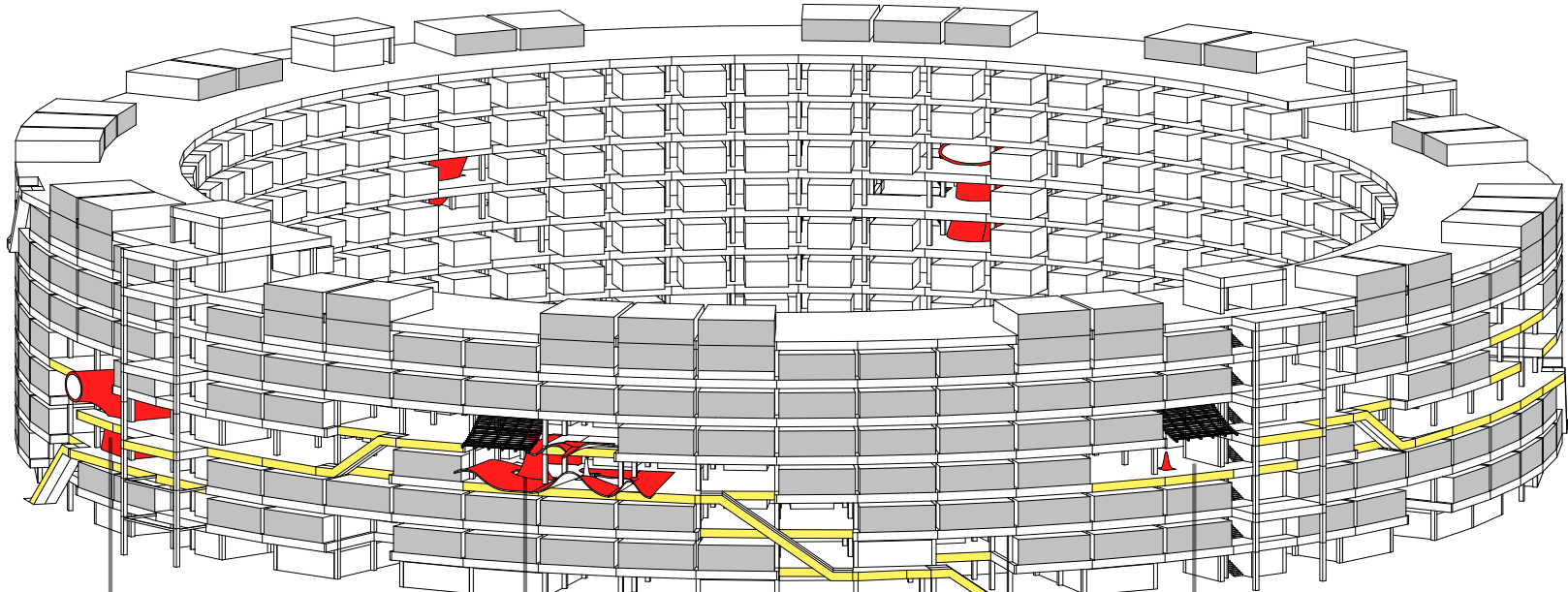
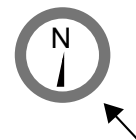

community office area neo-Chinese garden area dry garden area

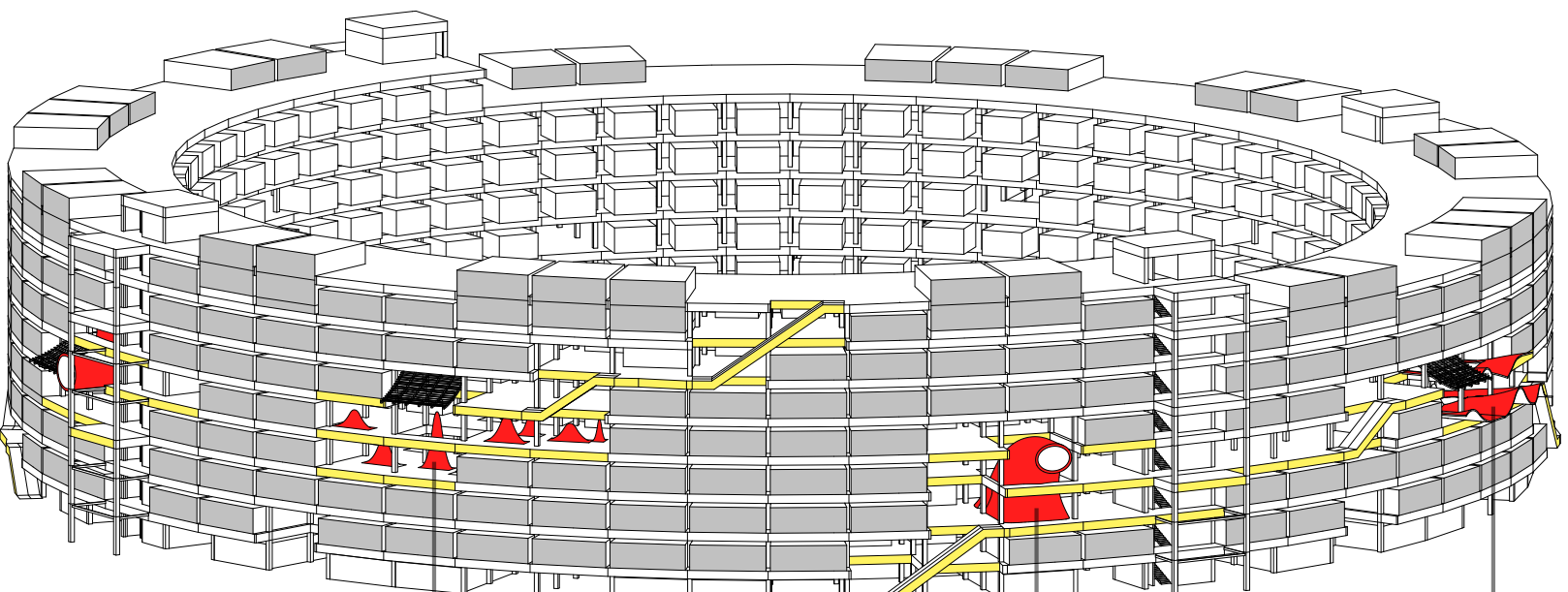
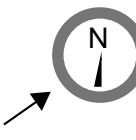

mountain garden area community office area neo-Chinese garden area

Urban Location

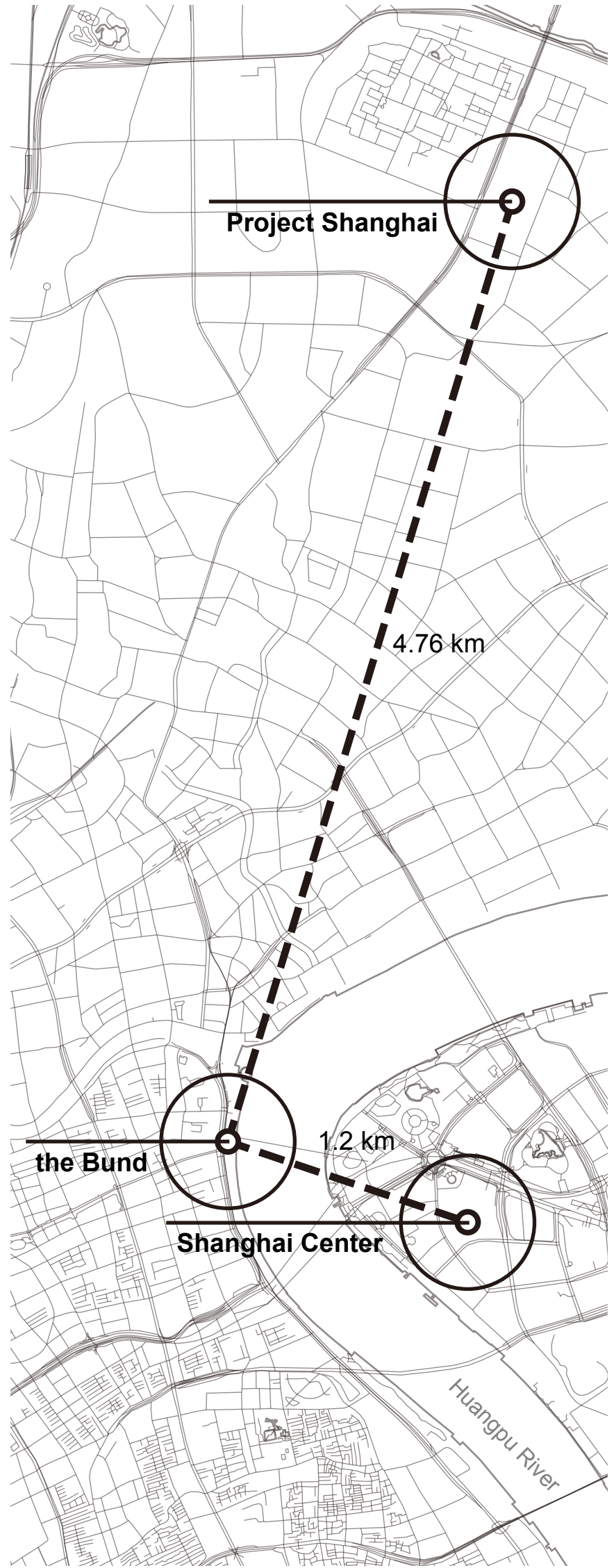

Master Plan 1:2500

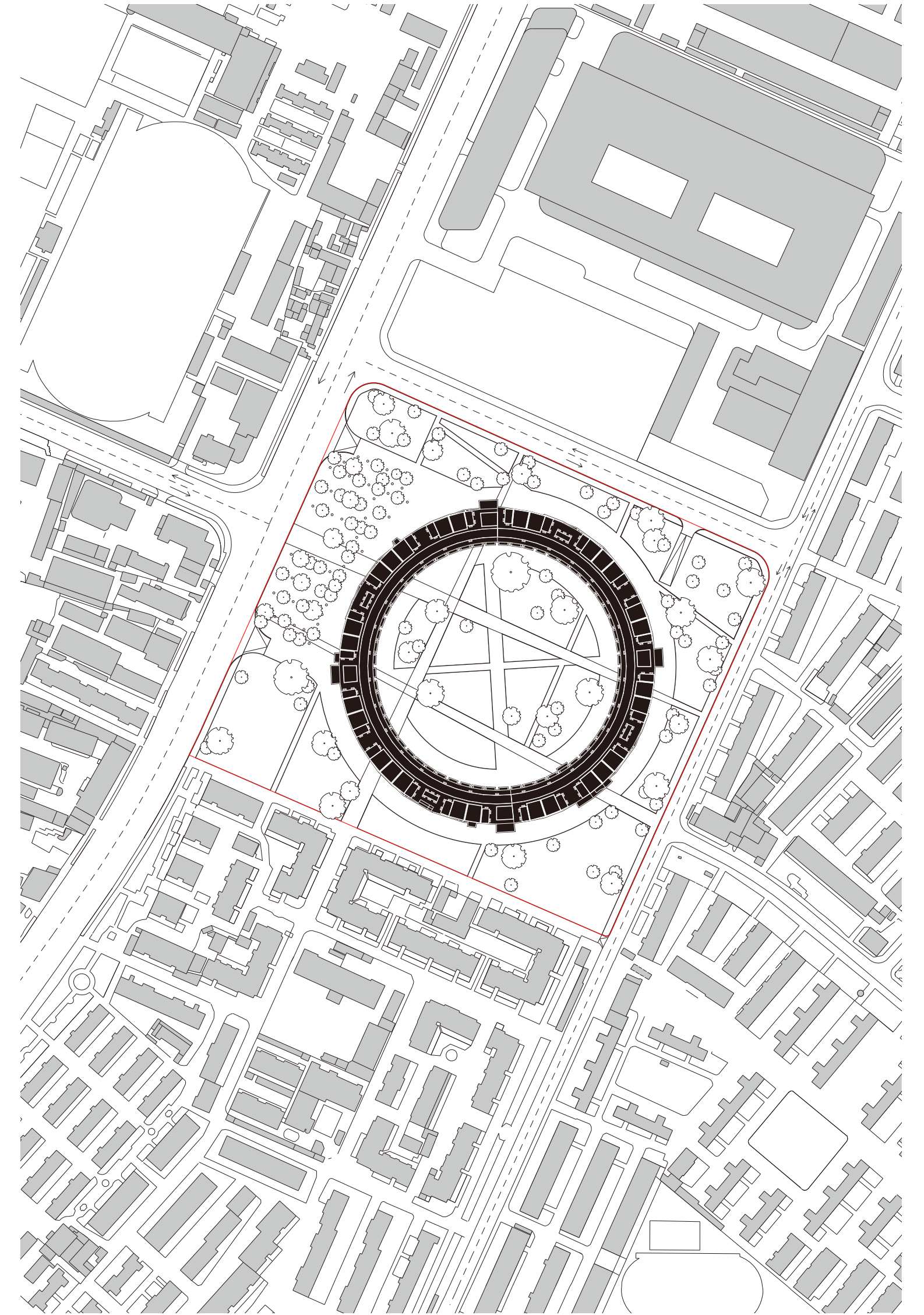
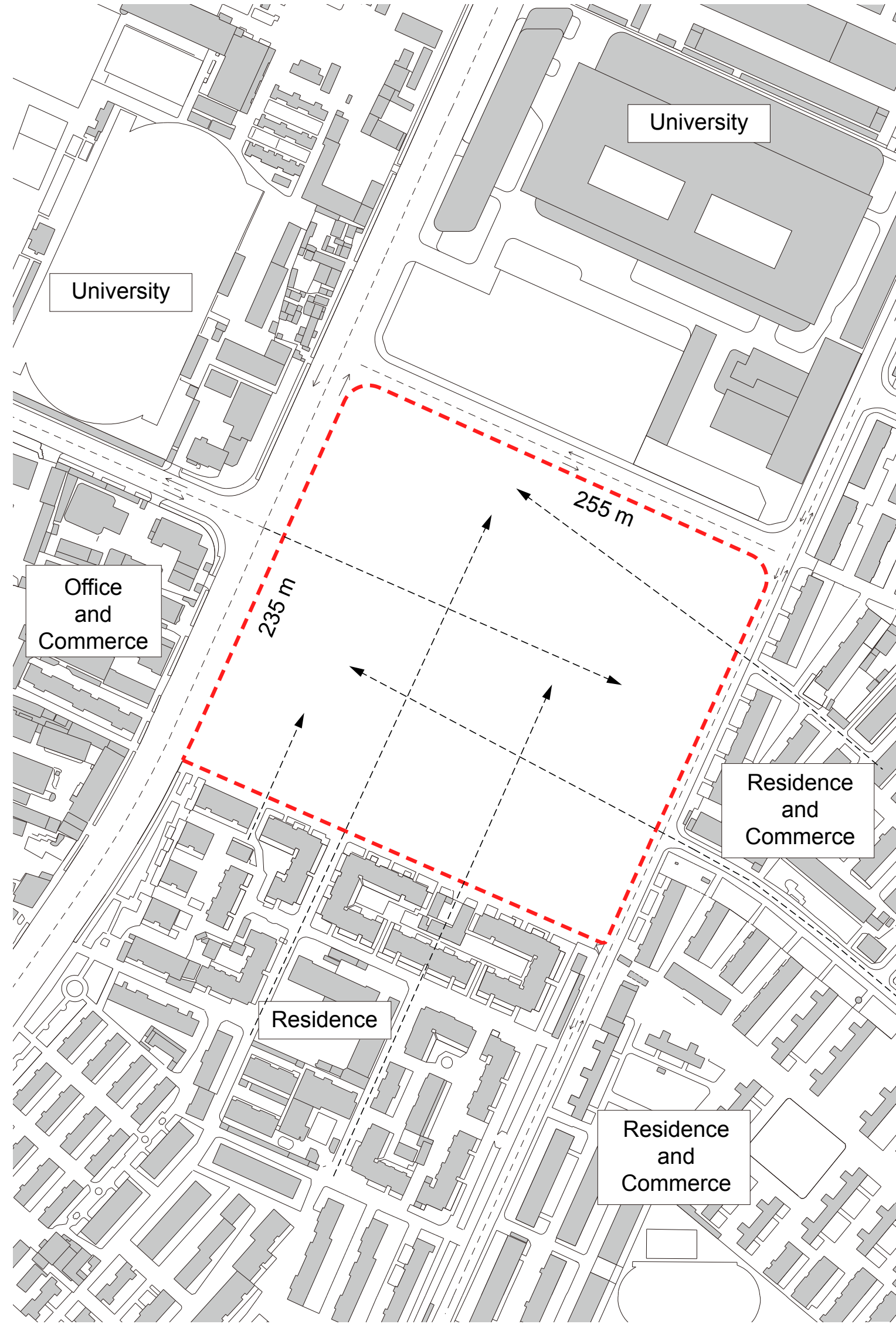

Ground Floor Plan 1:800

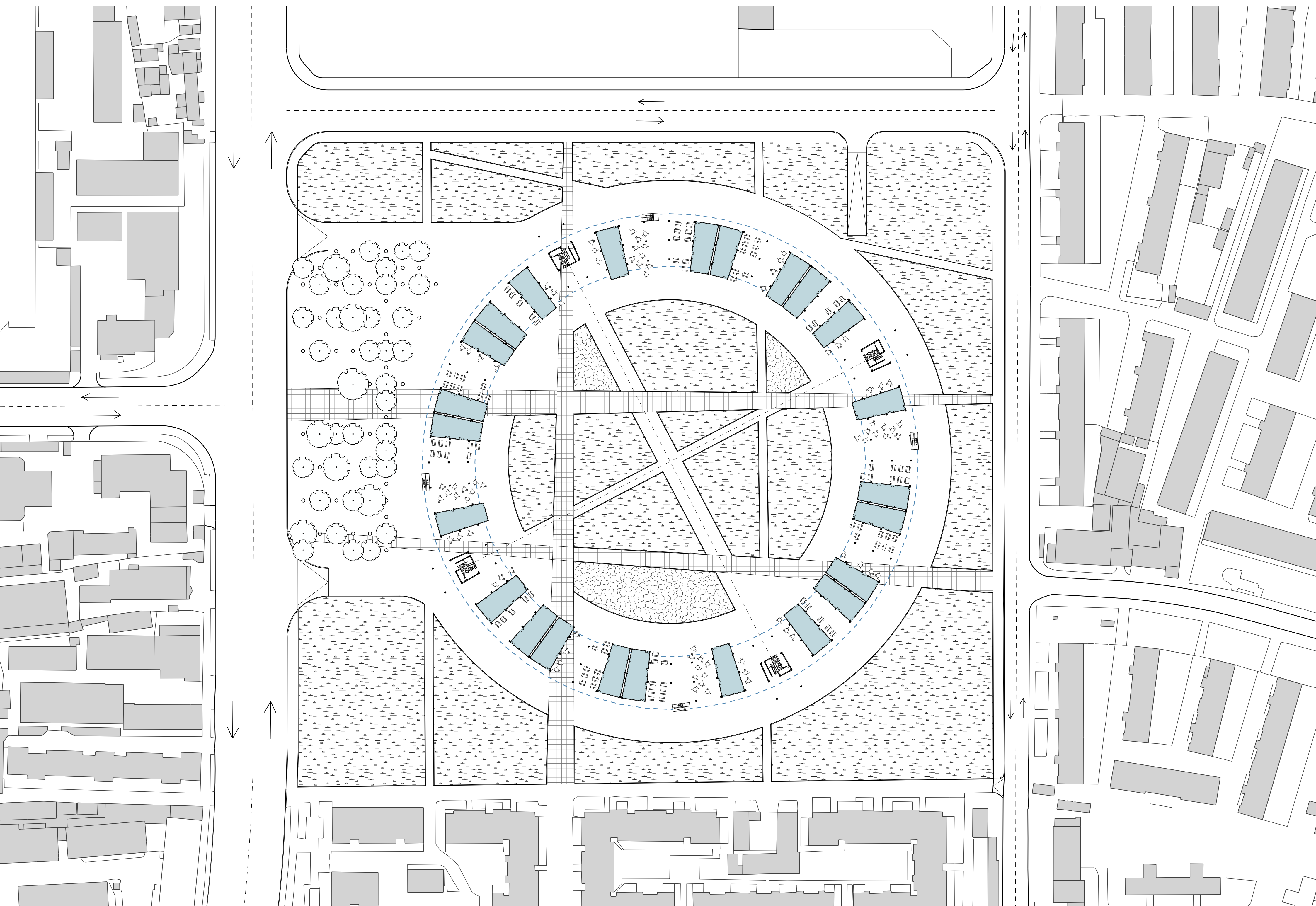
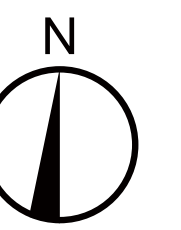
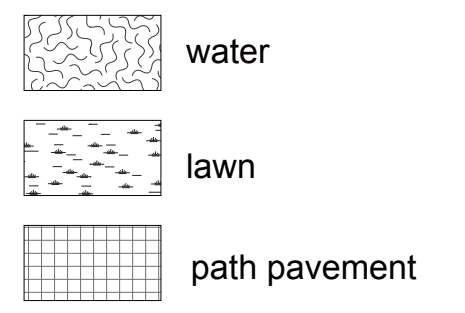

Floor Plans 1:800

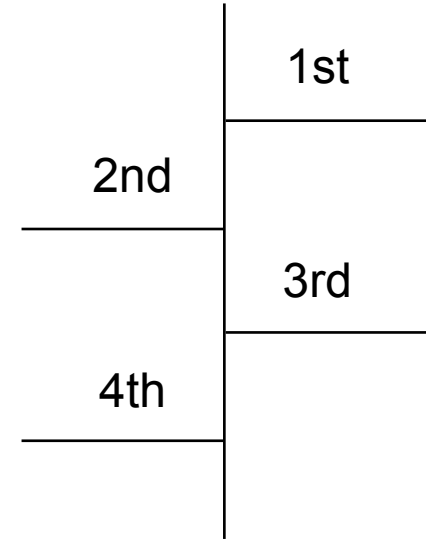
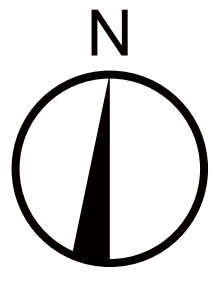
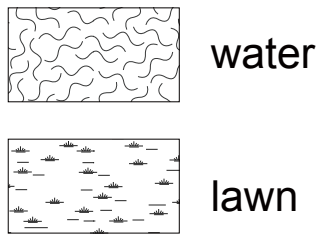

Roadside Cafe #1

Roadside Cafe #2

Roadside Cafe #3

70.5 m
88.5 m

Community Office Area

Restaurant Area

Exhibition Area #1:
sculptures/installations

Exhibition Area #2:
2D/media arts

Cafe Area

Dry Garden Area

Restaurant Area

Exhibition Area #1:
sculptures/installations

Exhibition Area #2:
2D/media arts

Mountain Garden Area

Neo-Chinese Garden Area

Cafe Area

Community Office Area

Dry Garden Area

Mountain Garden Area

Community Office Area

Neo-Chinese Garden Area

Floor Plans 1:800

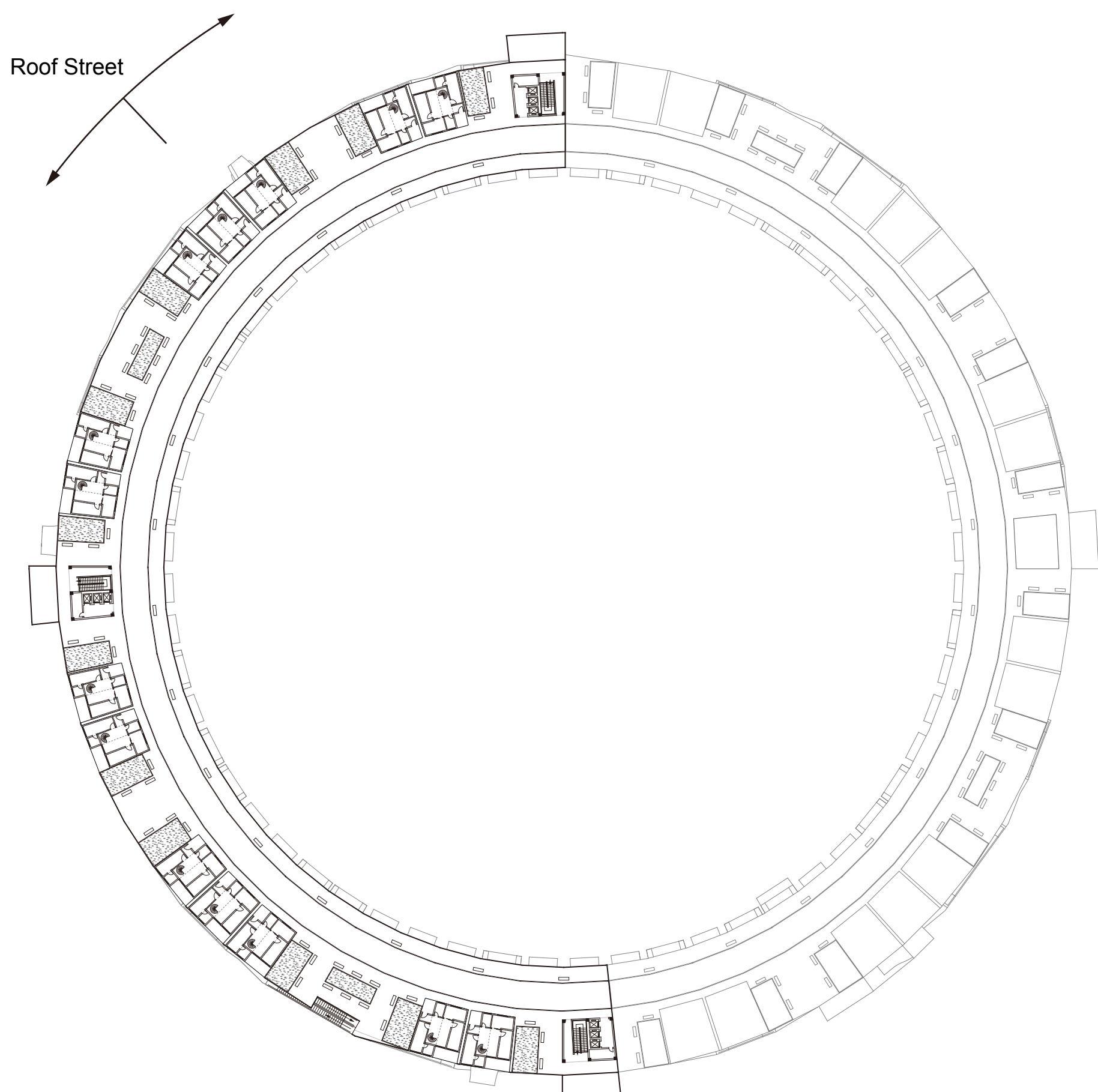
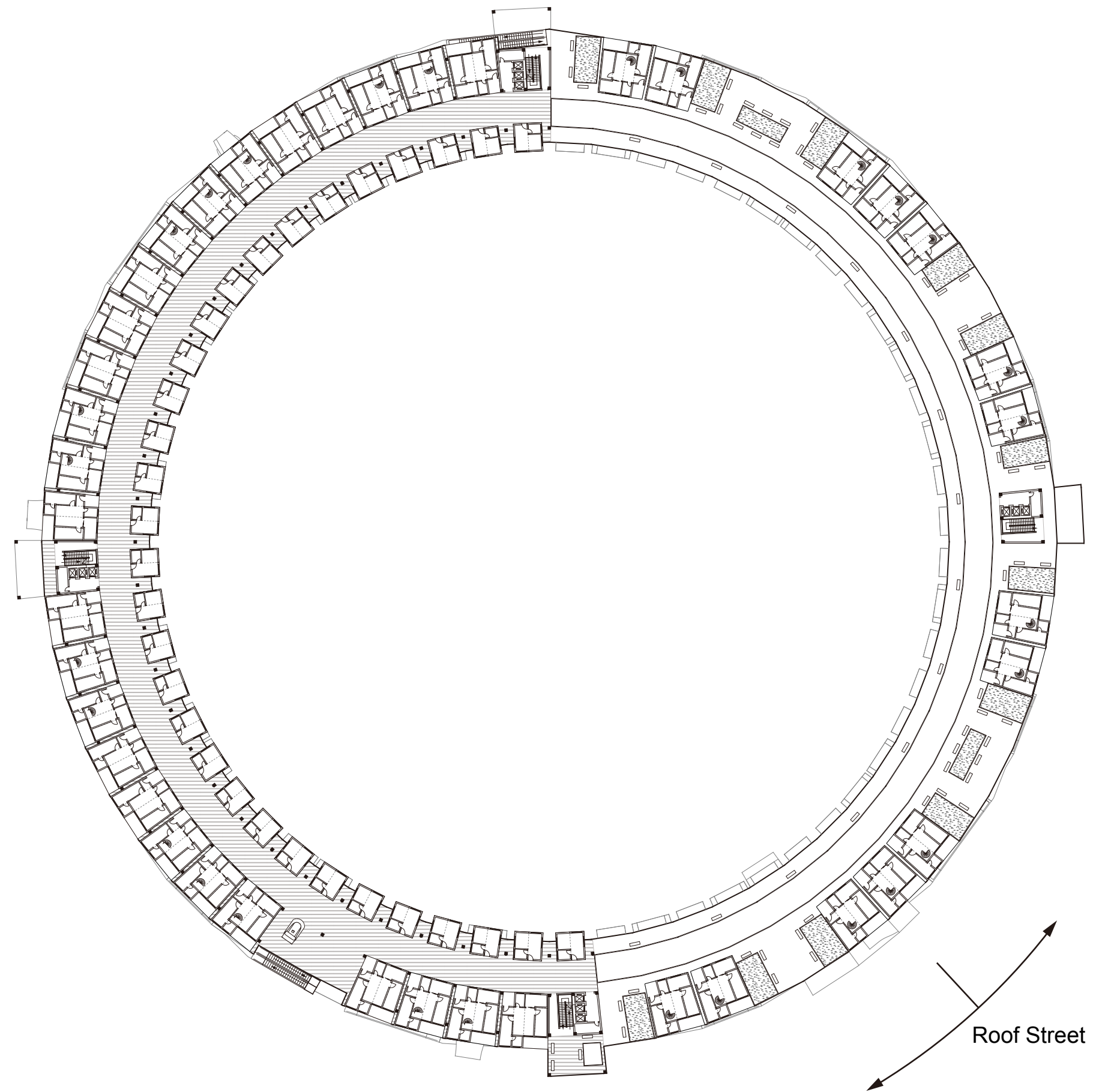
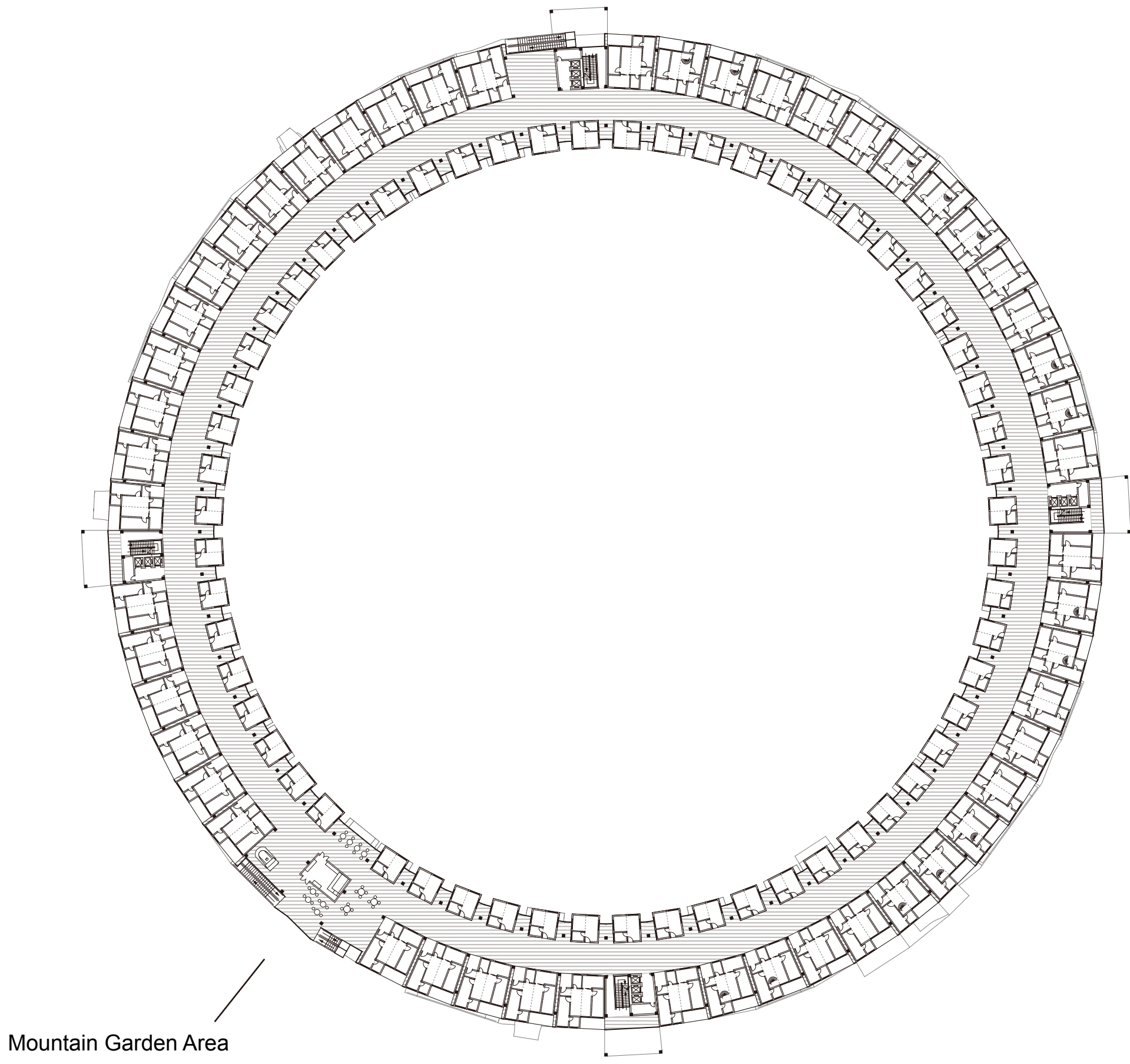
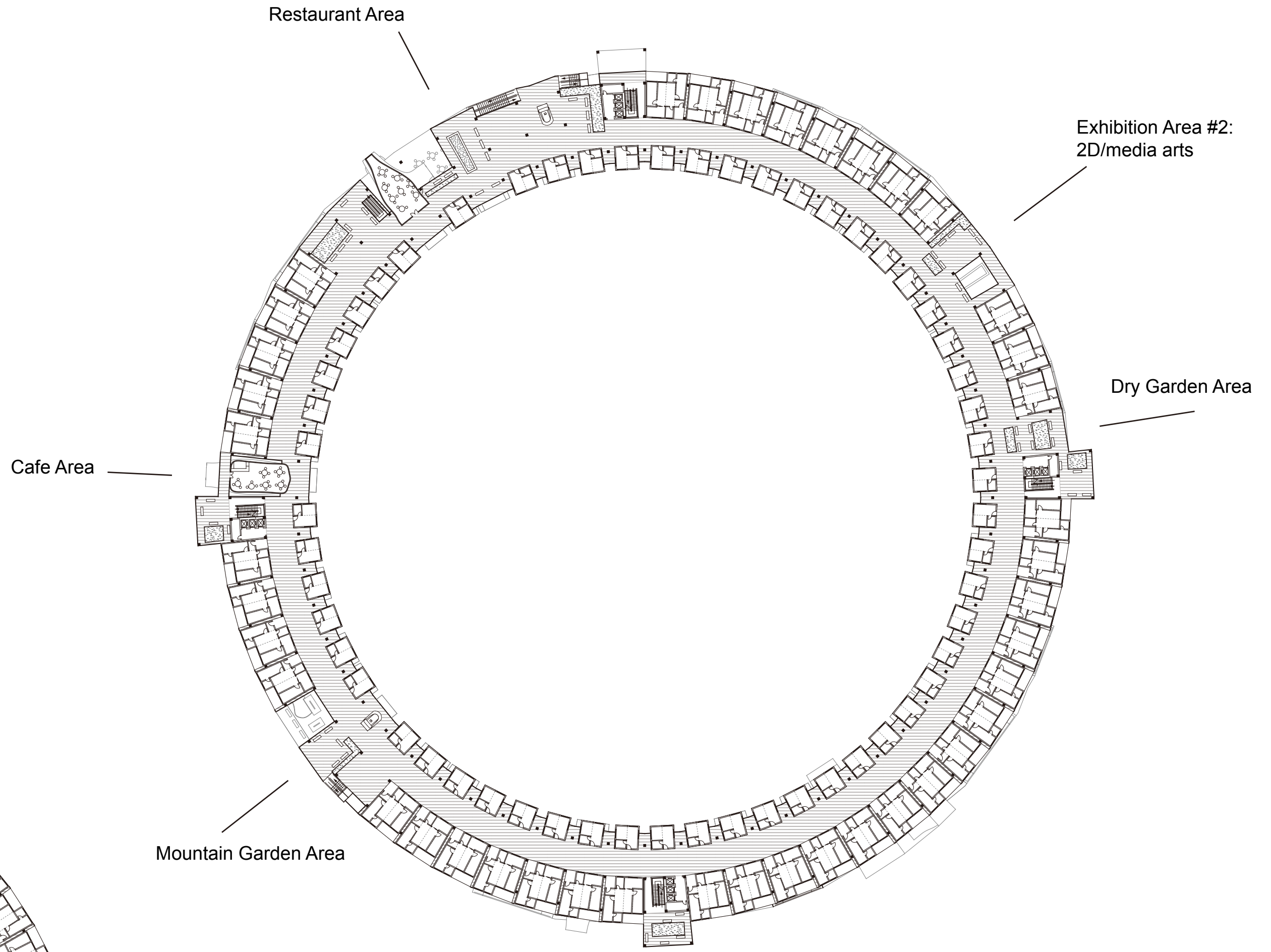
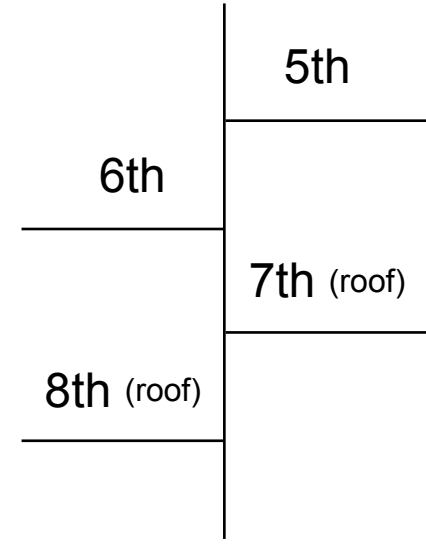
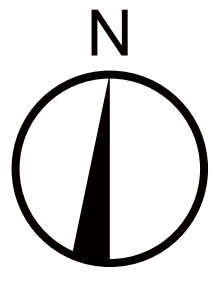
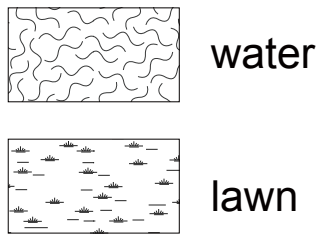

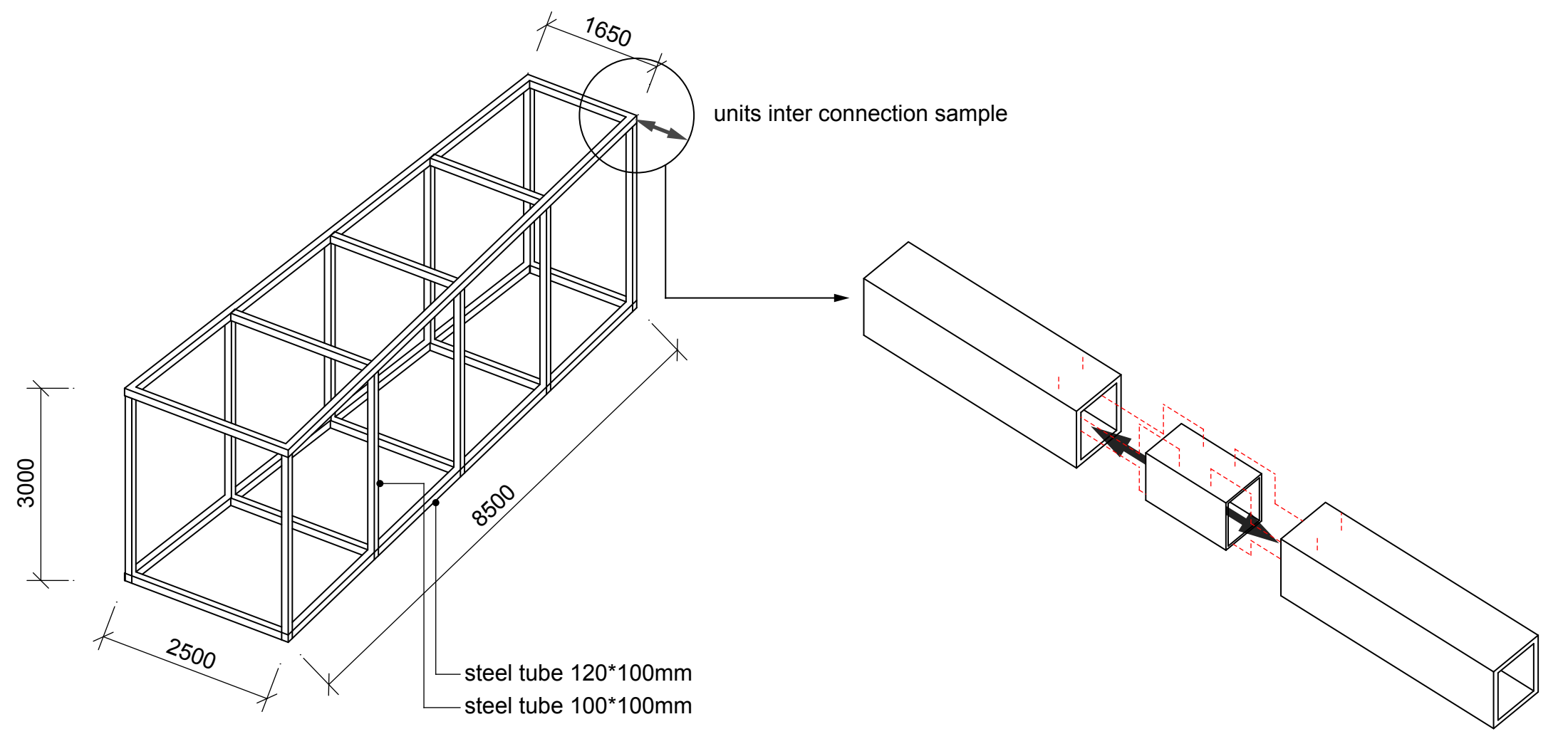
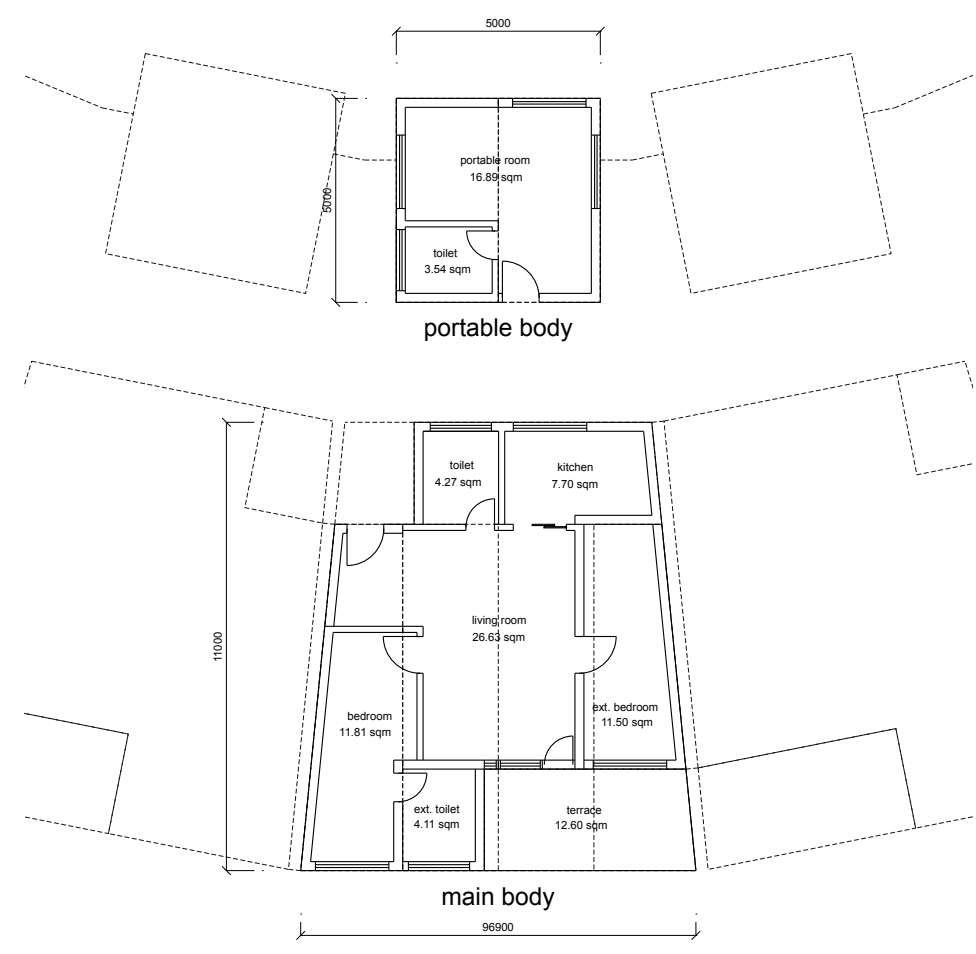

Structural Schemes

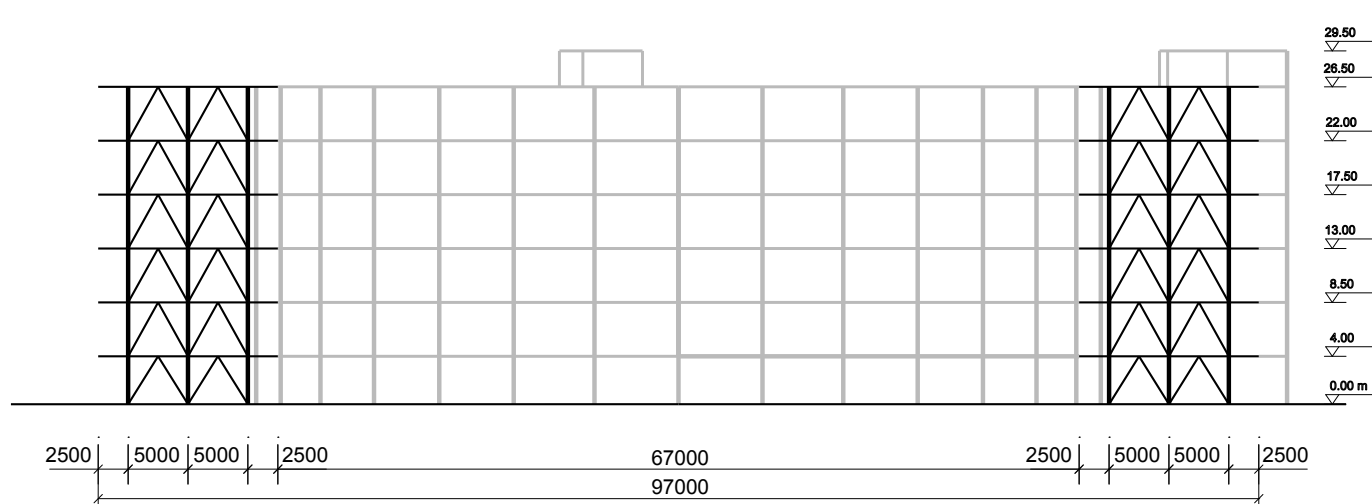
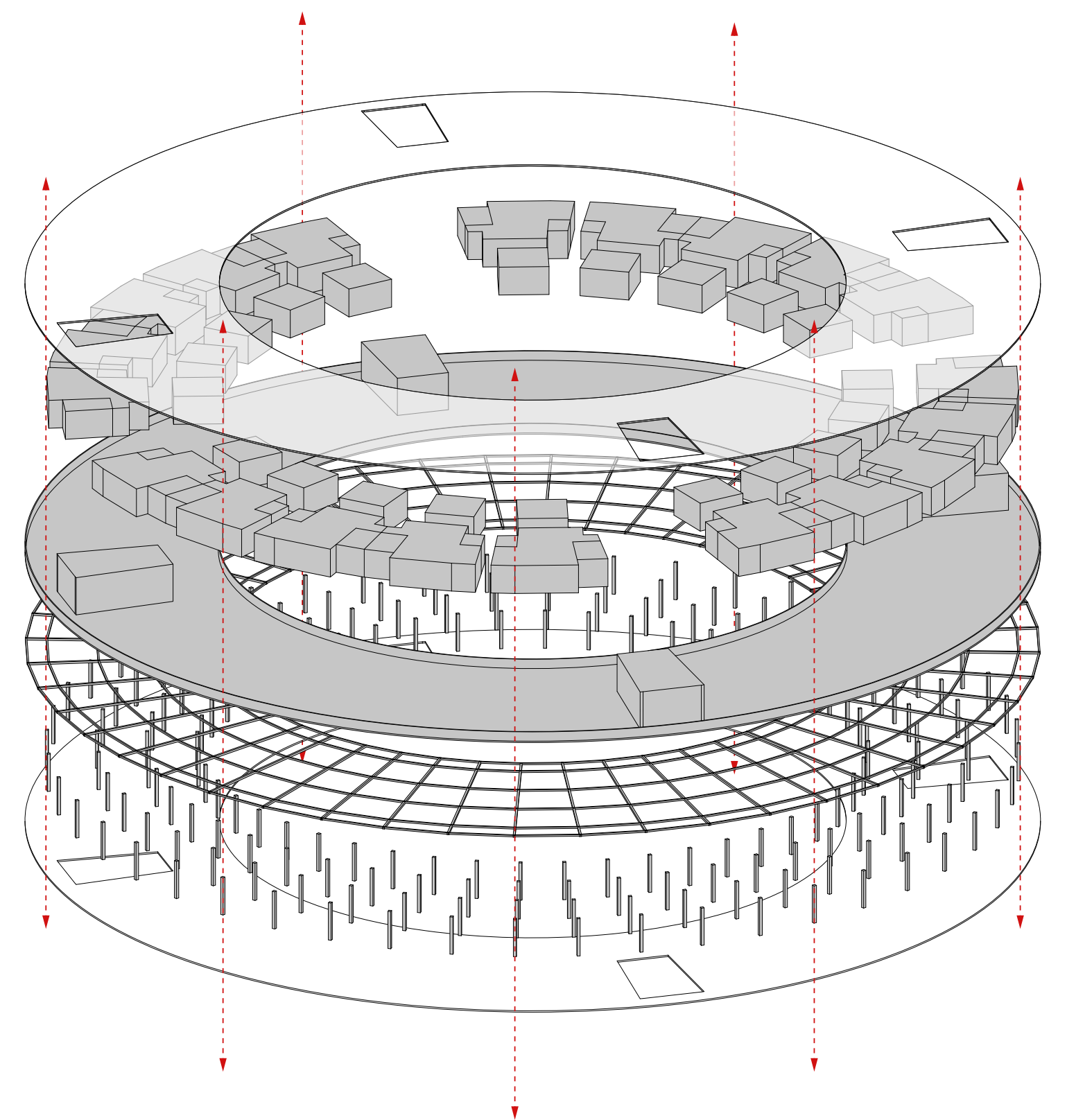
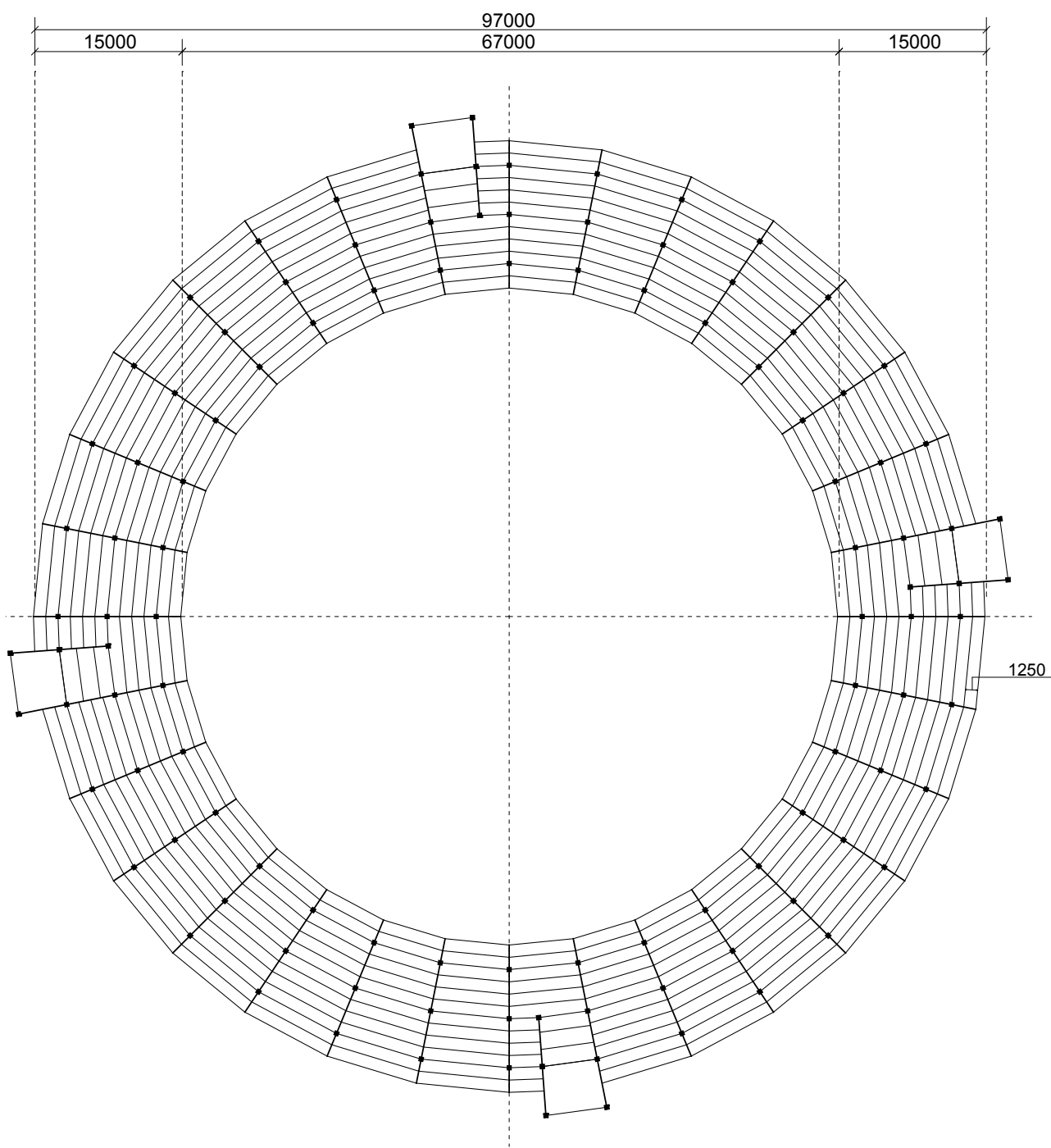
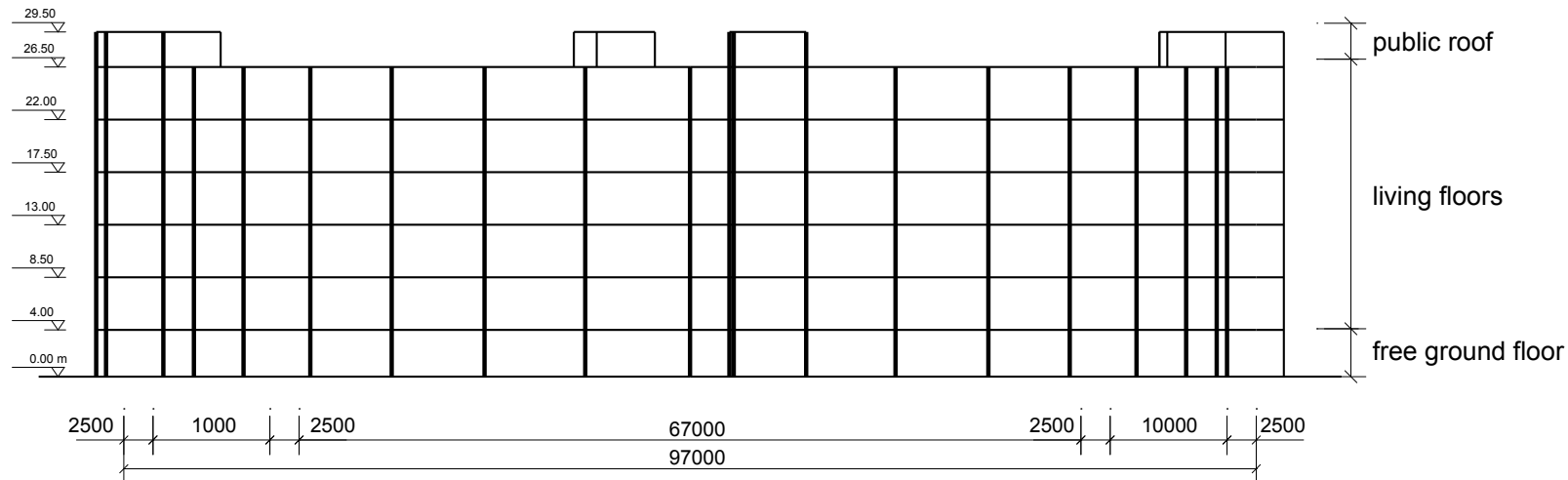

Connection Examples

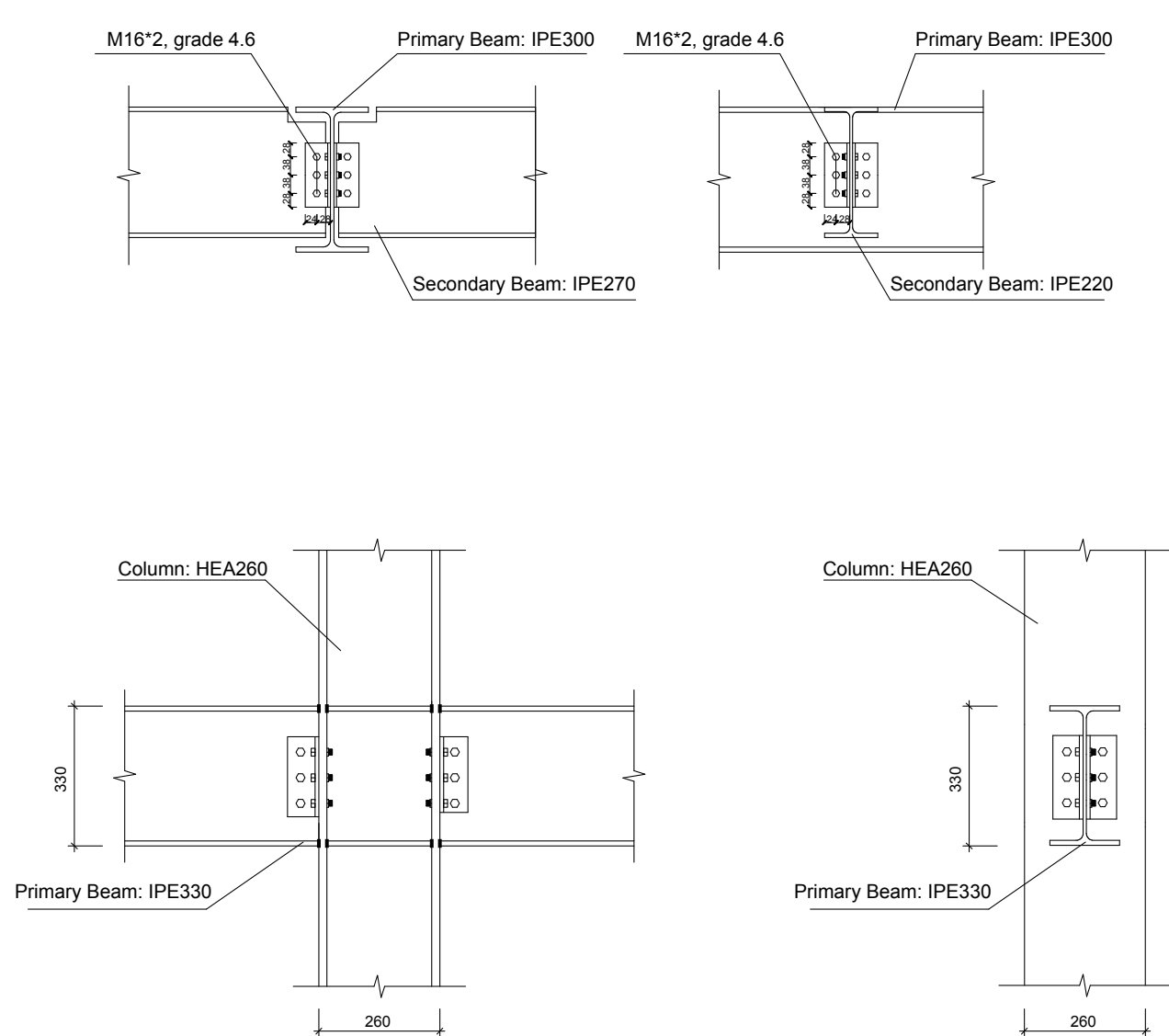

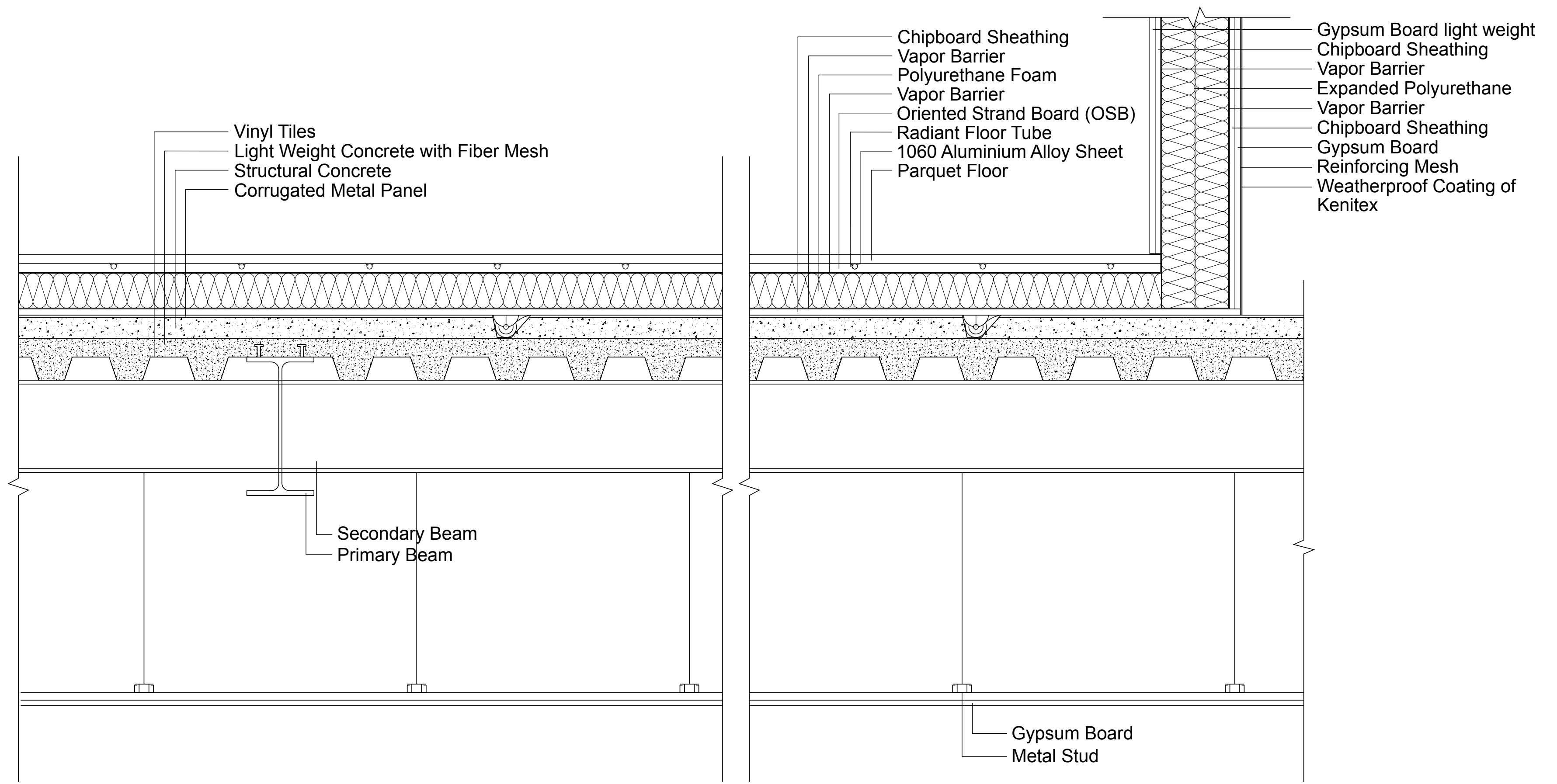

Installation Process

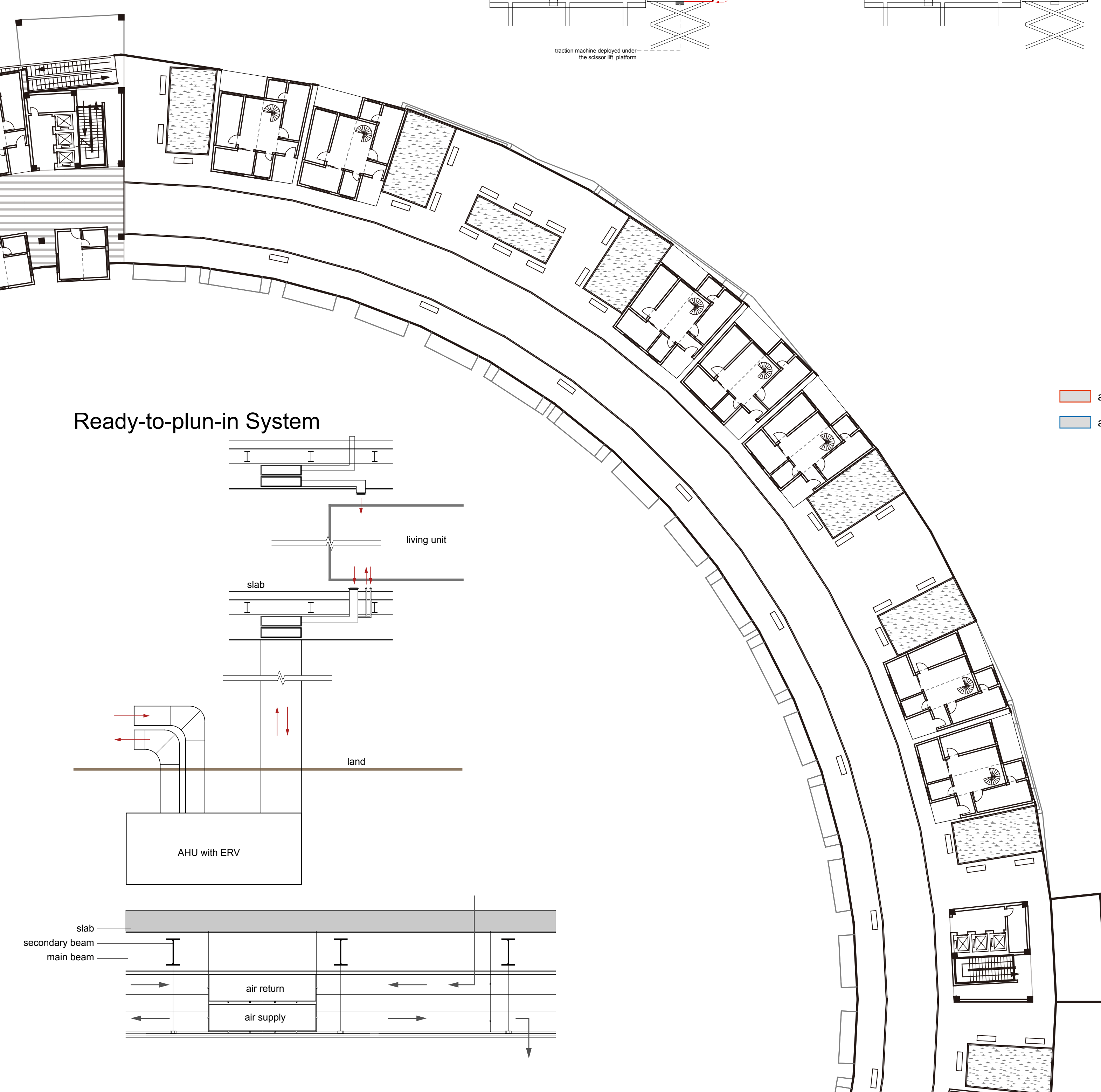
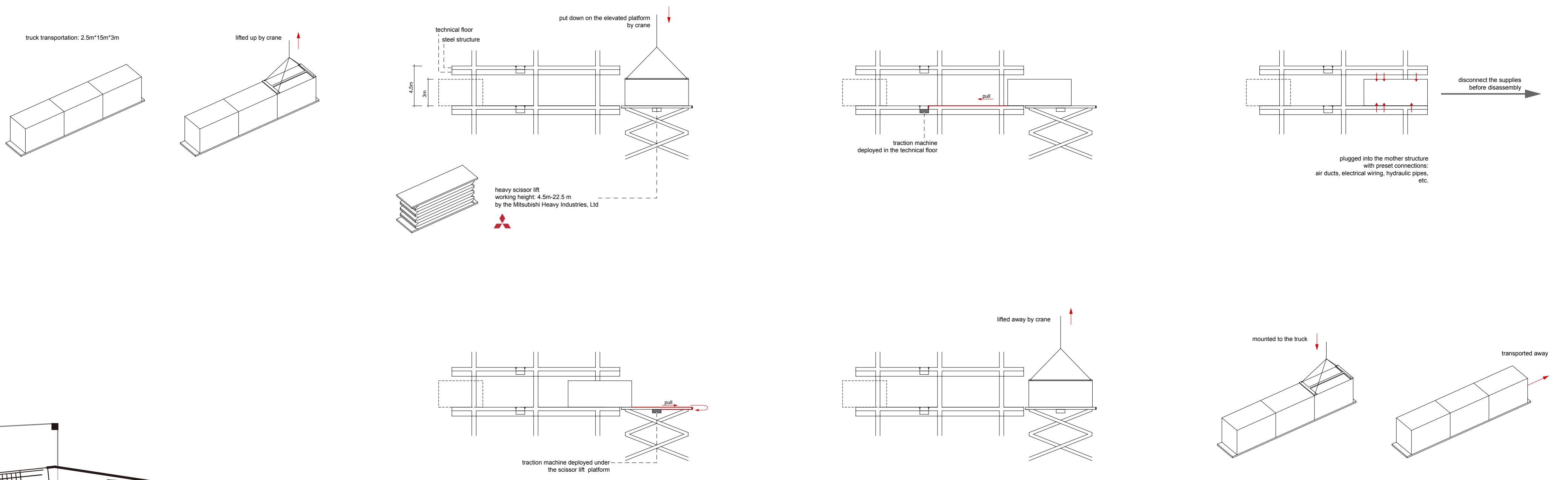

Ready-to-plug-in System

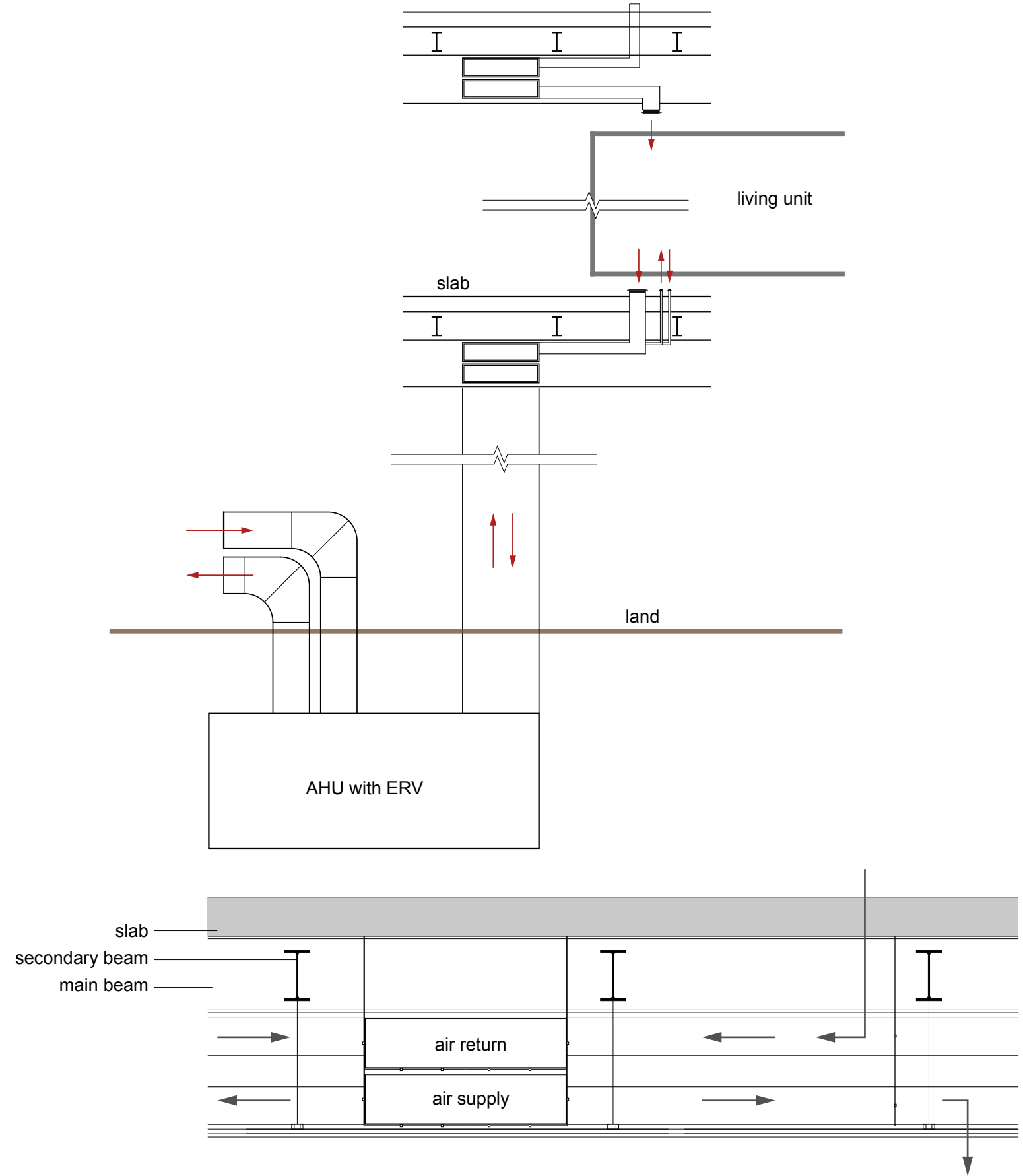

Mechanical Ventilation

- air supply
- air return

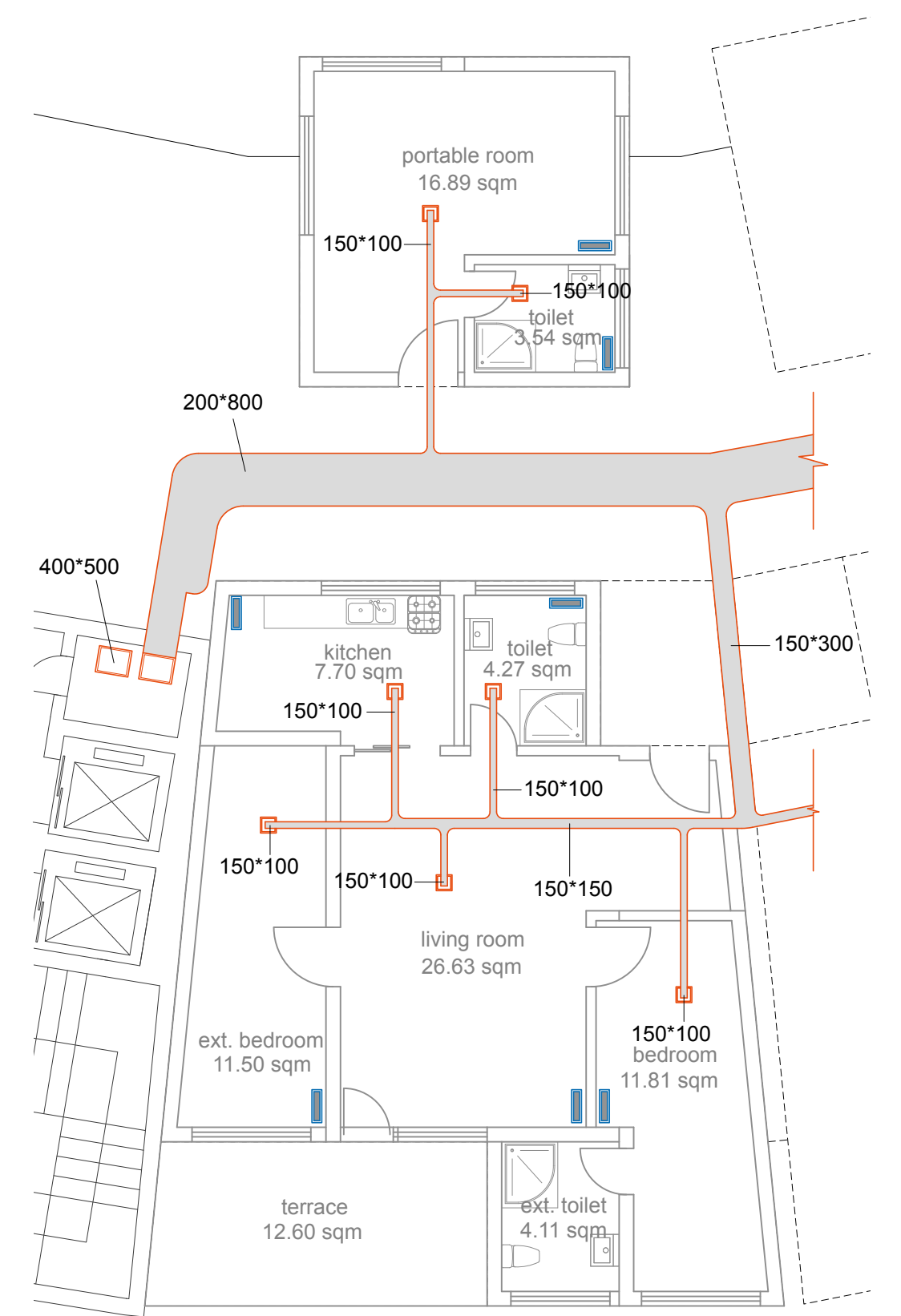

the M.I.A spreading

contextualization & self-contextualization



New York



Pyongyang

