

Master Plan Generation

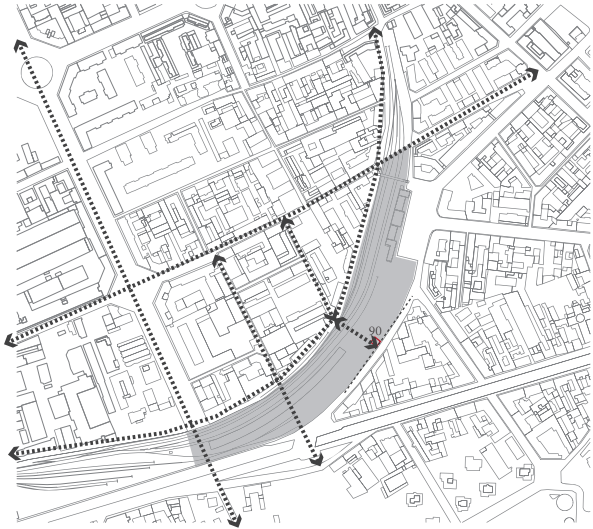

connect urban mobilities



site split by mobility



secondary mobility of the site

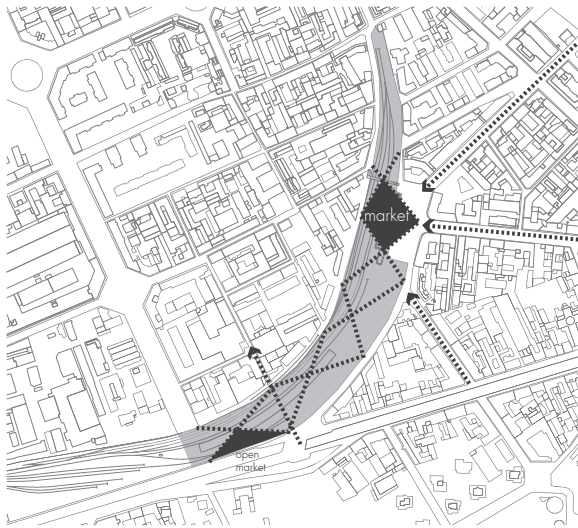

the focus of the urban mobility decide the position of the architecture

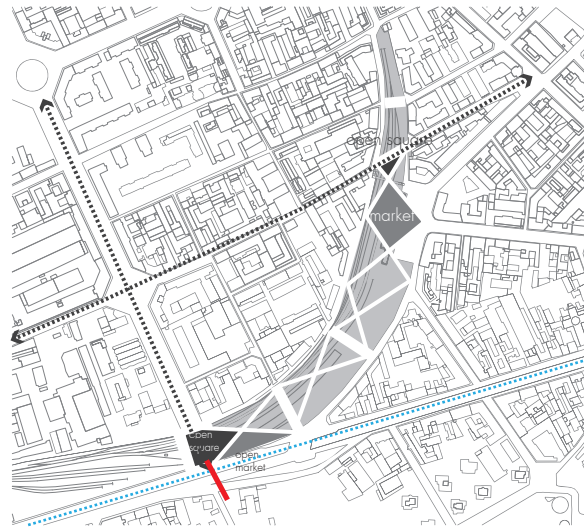

common grounds are settled for important urban mobility knot



urban function added

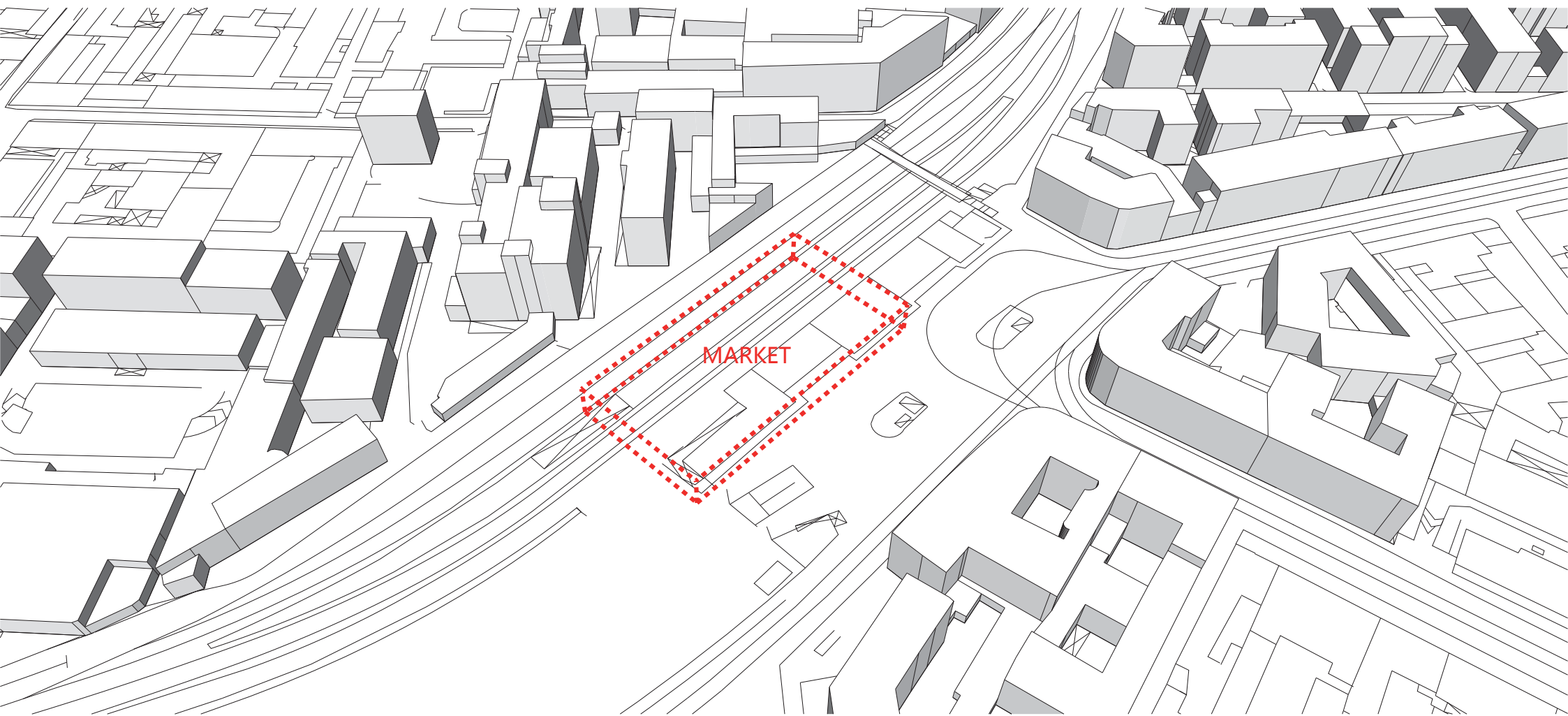

MARKET

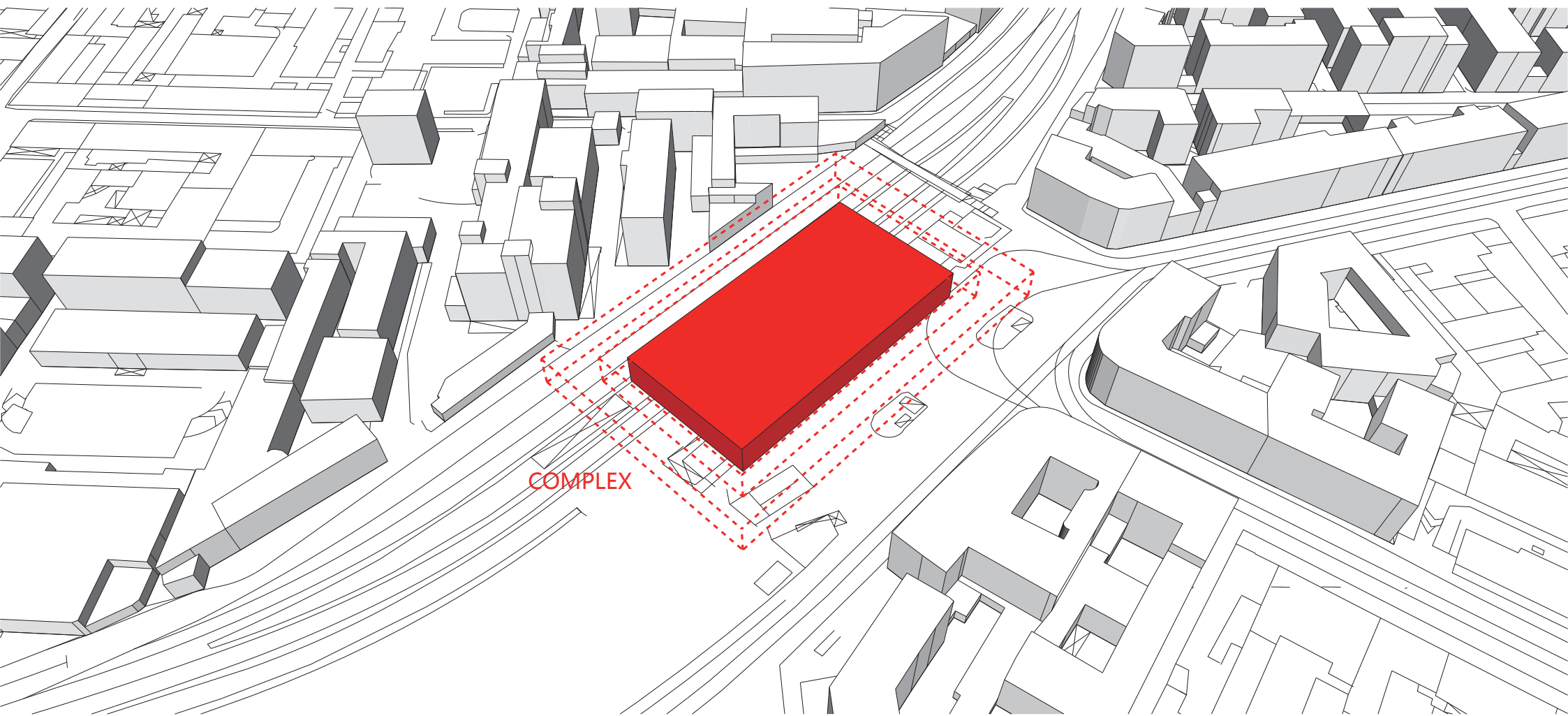

COMPLEX

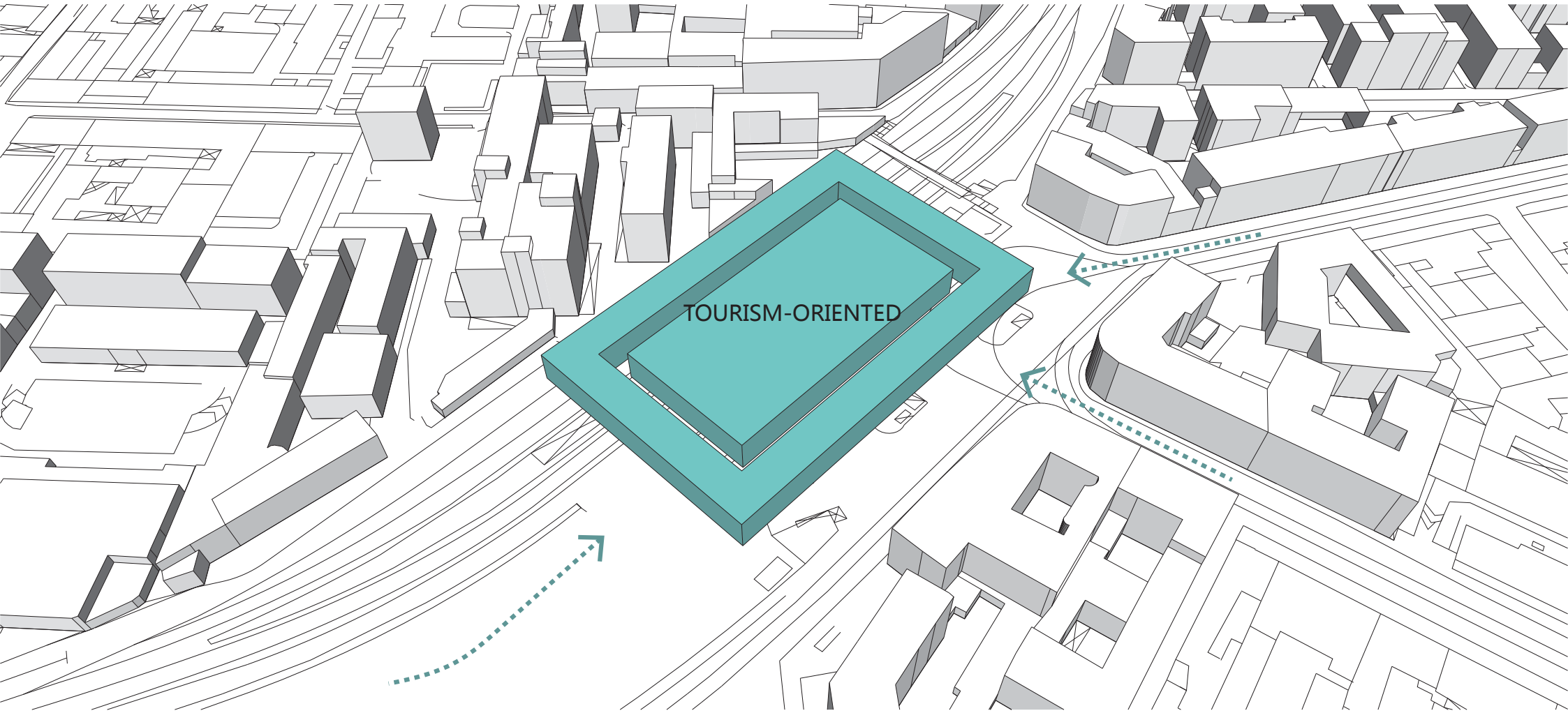

TOURISM-ORIENTED

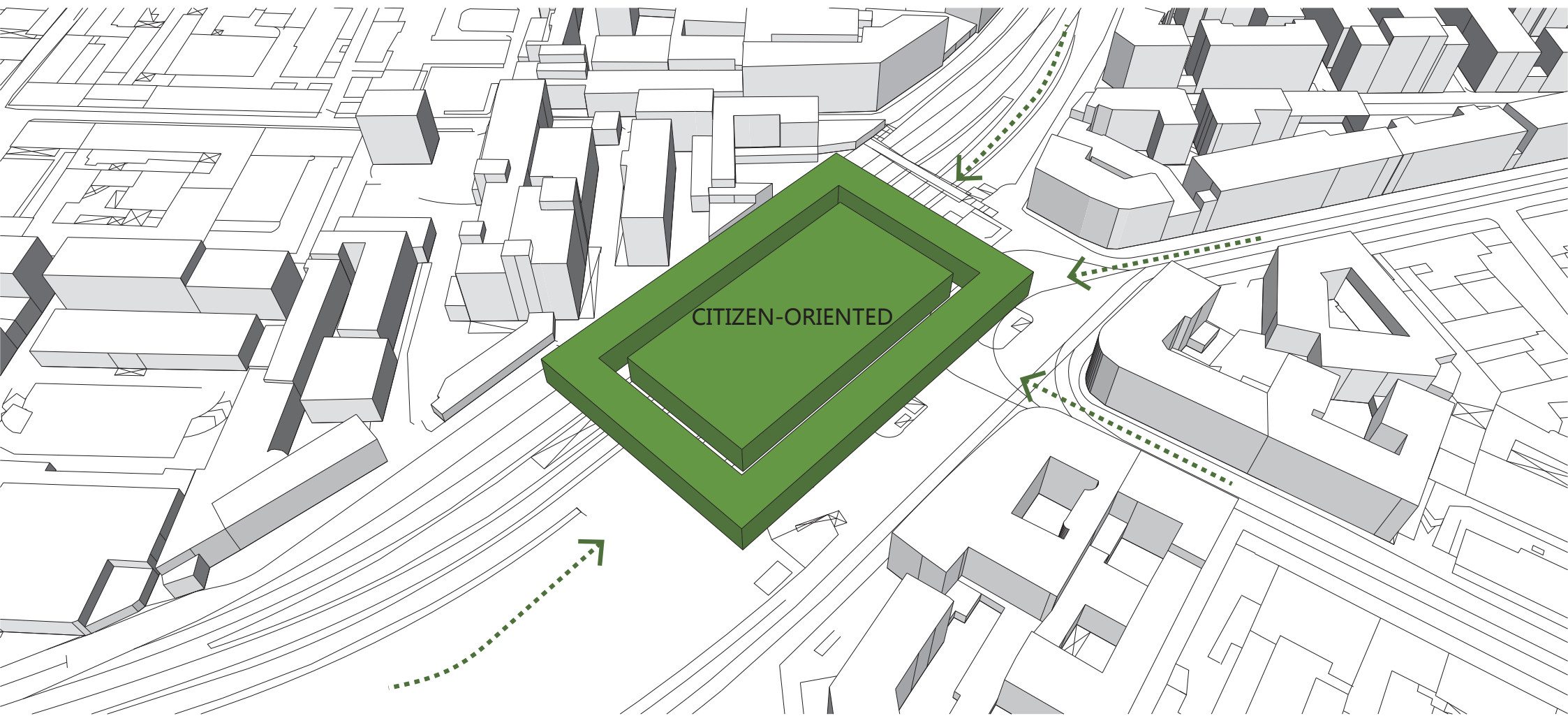

CITIZEN-ORIENTED

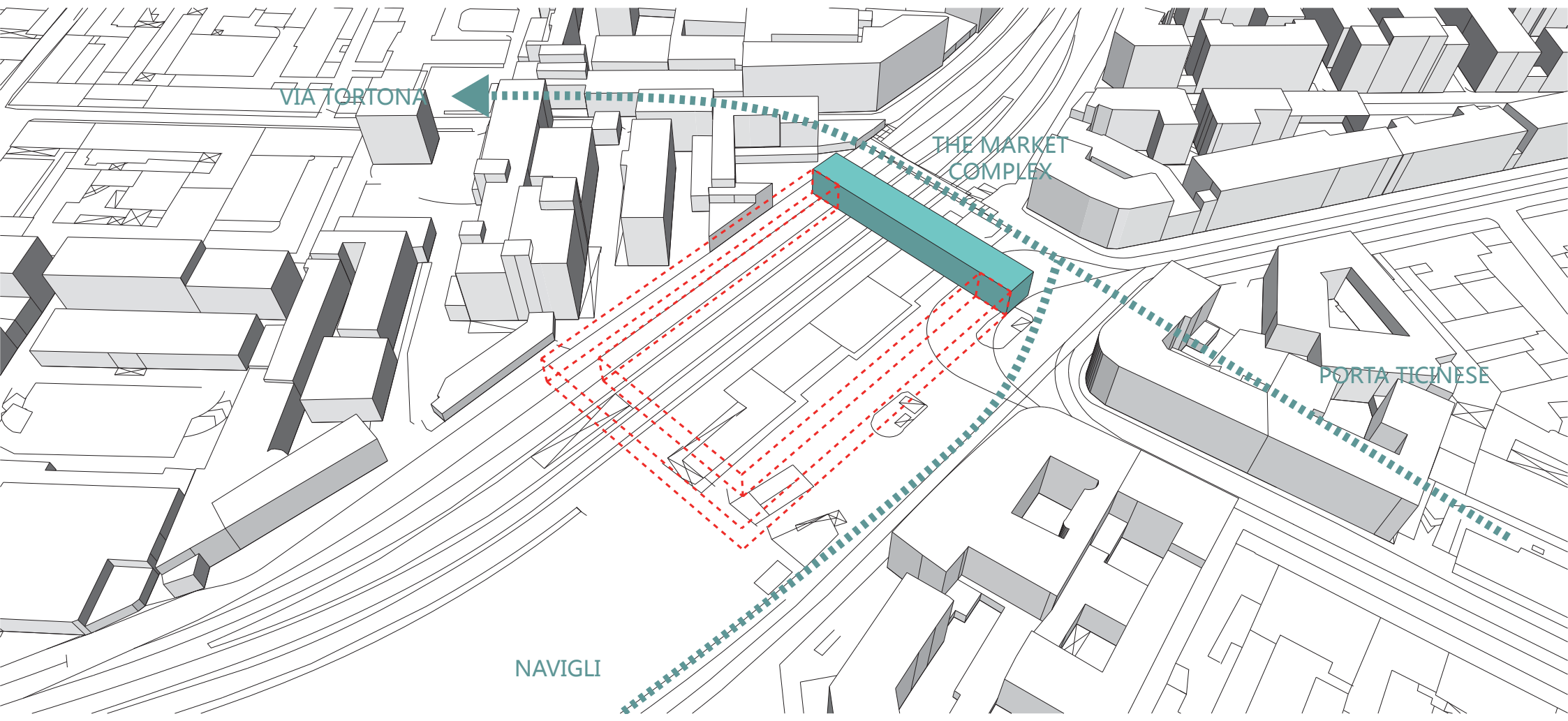

VIA TORTONA

THE MARKET
COMPLEX

PORTA TICINESE

NAVIGLI

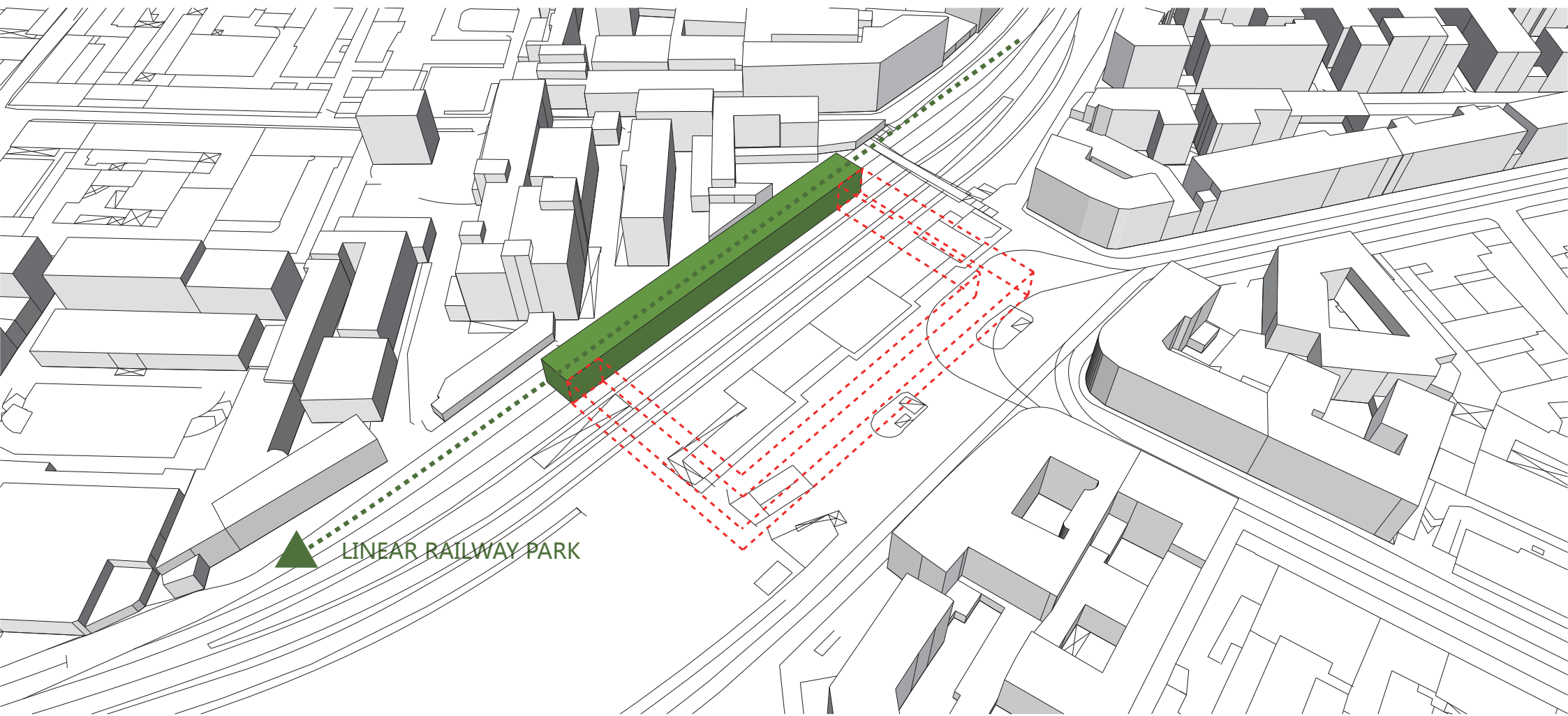

LINEAR RAILWAY PARK

TWO TYPICAL RELATIONSHIP BETWEEN INSIDE AND OUTSIDE

TOURISM-ORIENTED

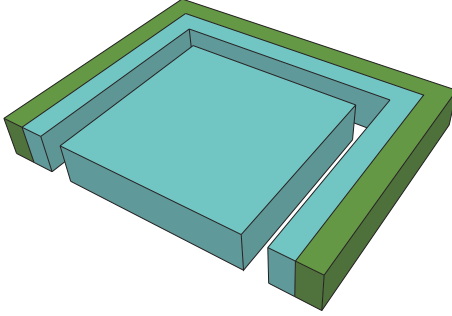
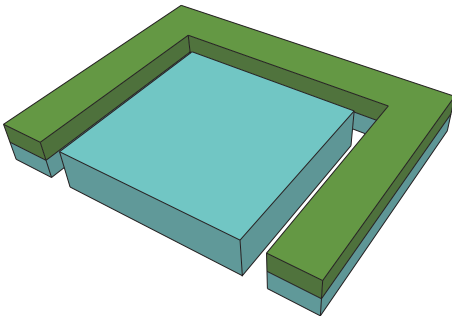

CITIZEN-ORIENTED

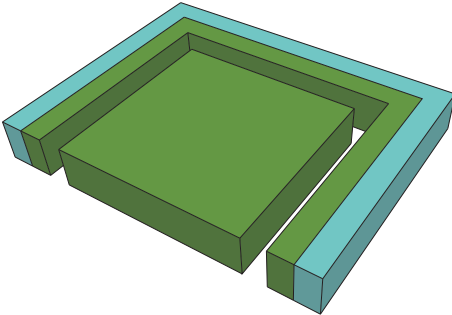
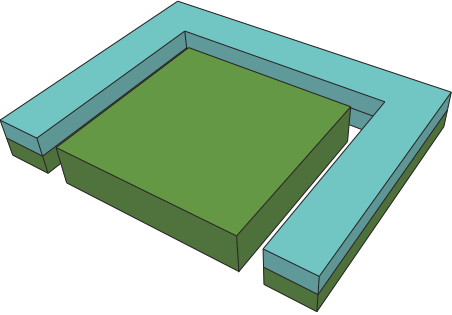

THINK ABOUT THE THIRD RELATIONSHIP

TOURISM-ORIENTED
FACADE

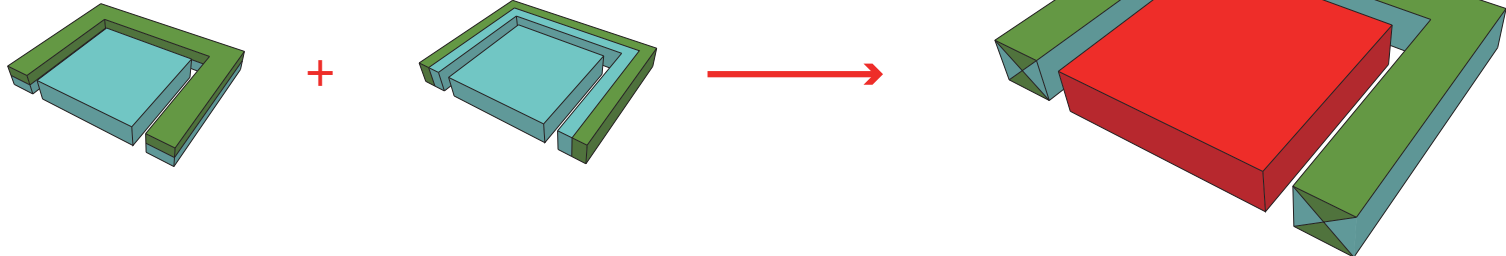

CITIZEN-ORIENTED
FACADE

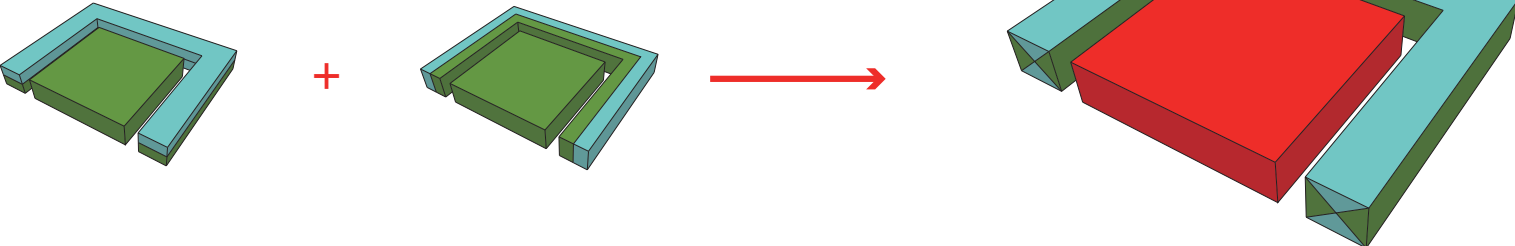

SOLUTION

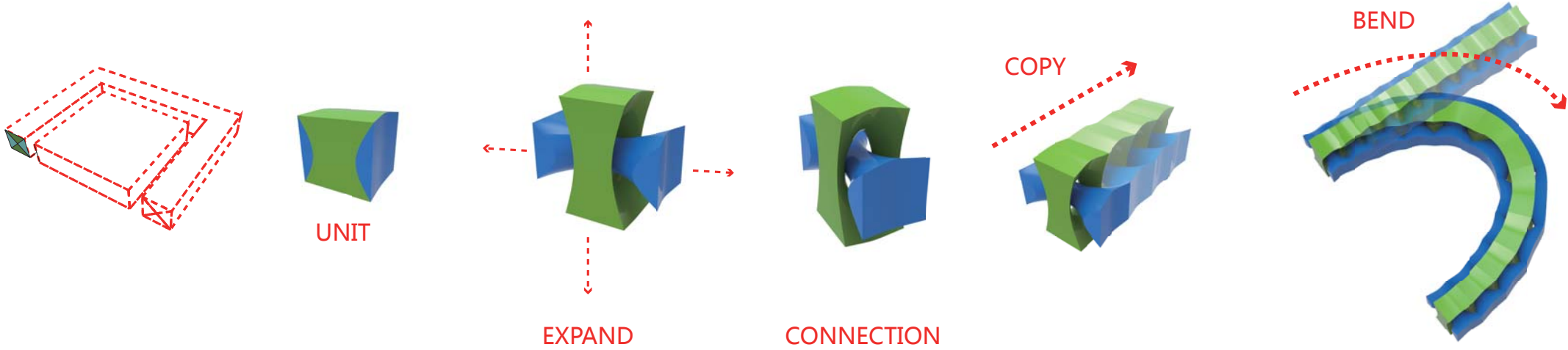

TRY TO FIND THE FOURTH RELATIONSHIP?

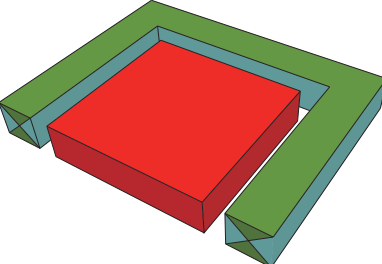

+

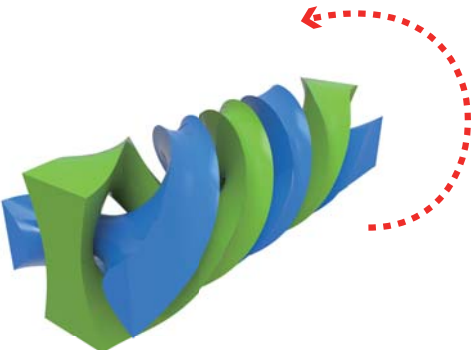
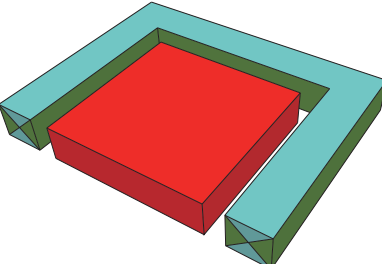

TWIST



SPACE MOBILITY

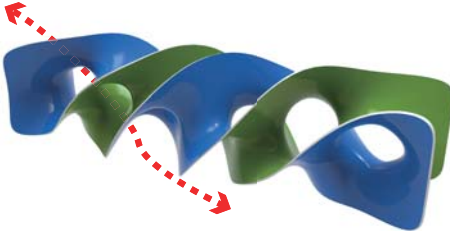

THE HOLE LINKING
INSIDE AND OUTSIDE

MAIN ENTRANCES

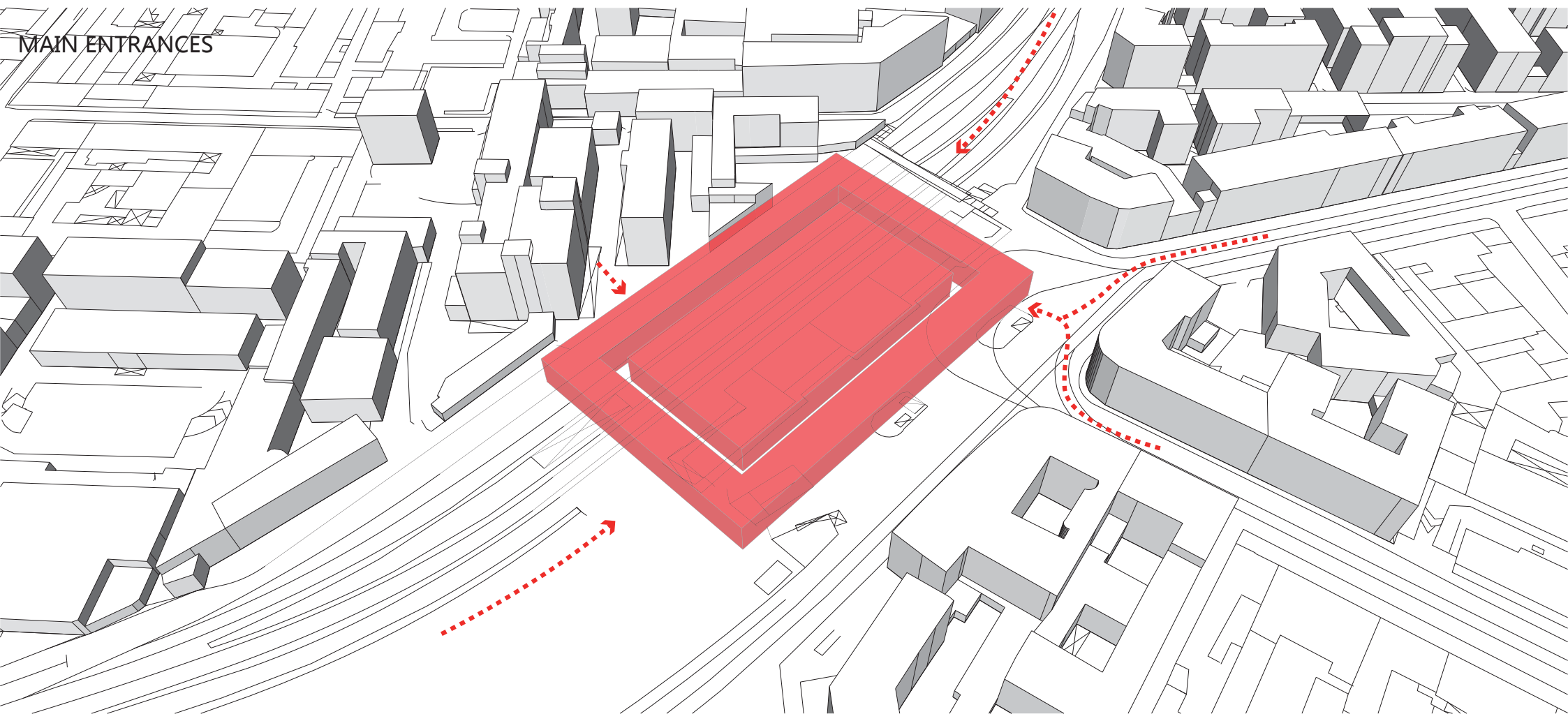

MOBILITY

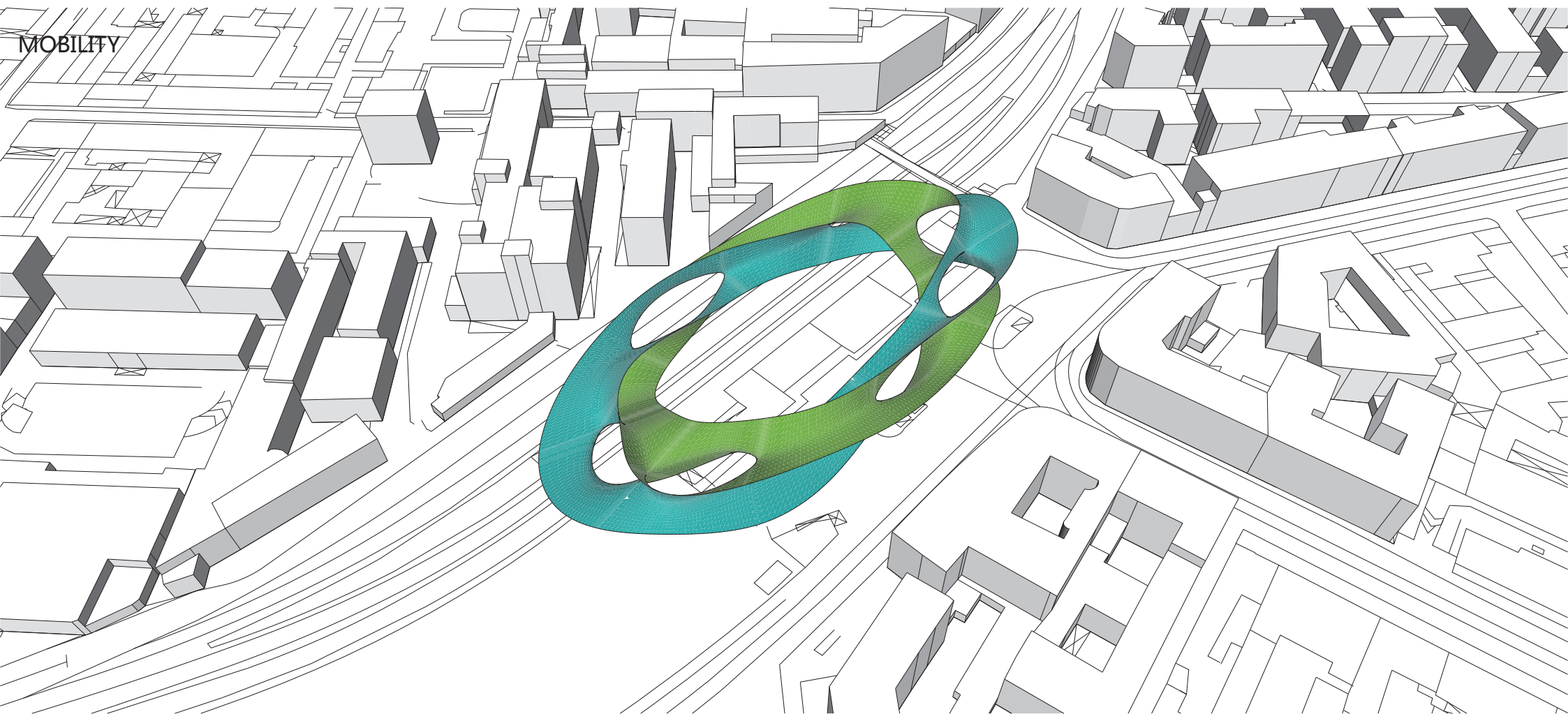

FUNCTION DIAGRAM

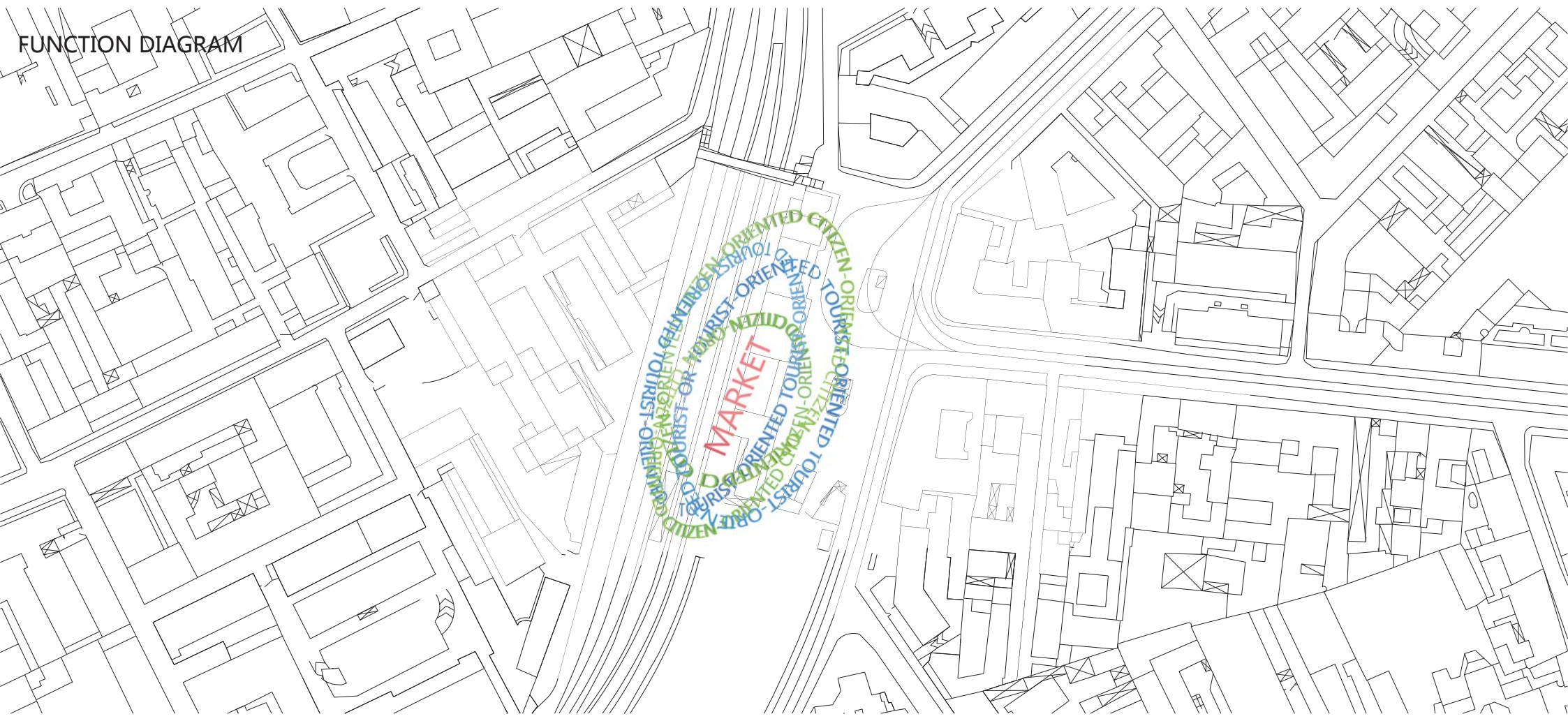

FUNCTION RELATIONSHIP IN 3 DIMENSION

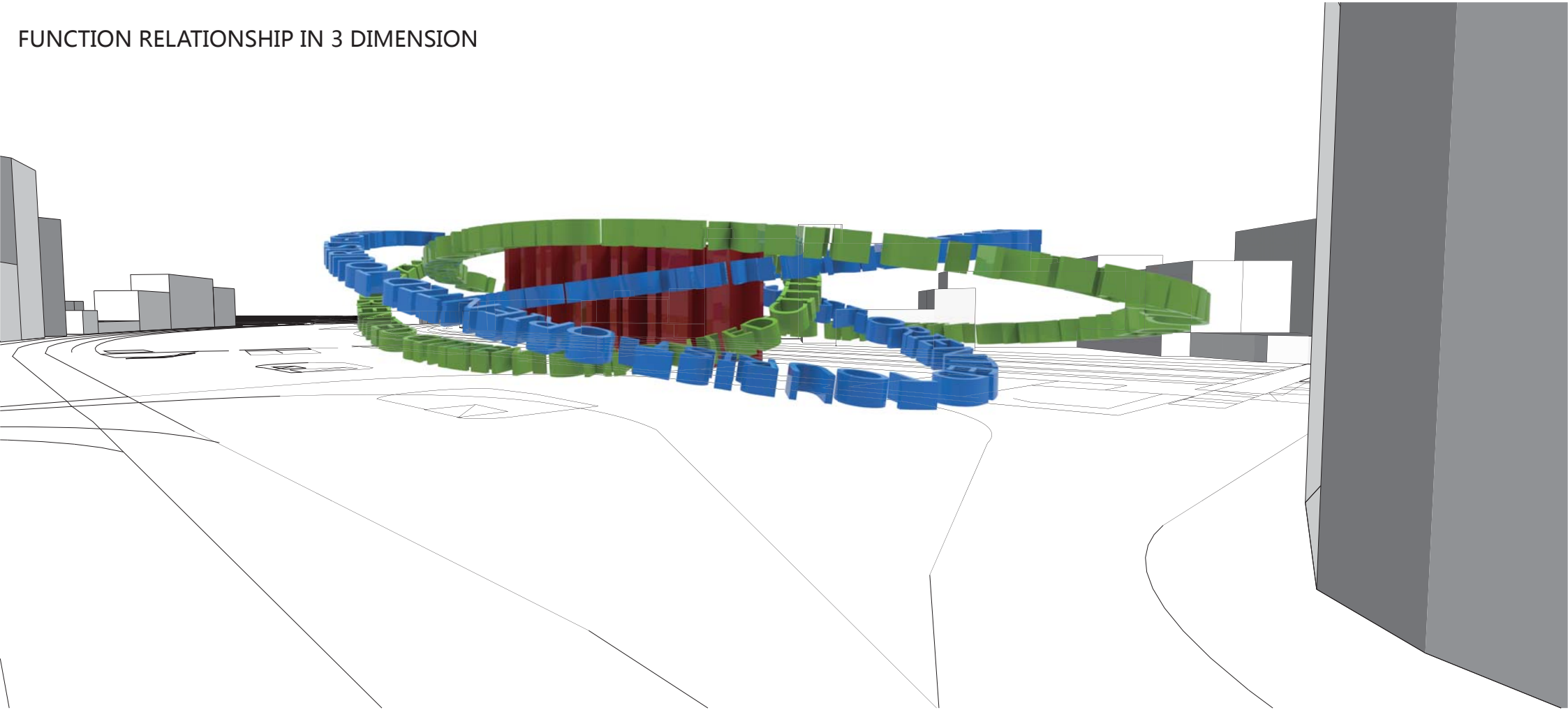

FUNCTION RELATIONSHIP IN 3 DIMENSION

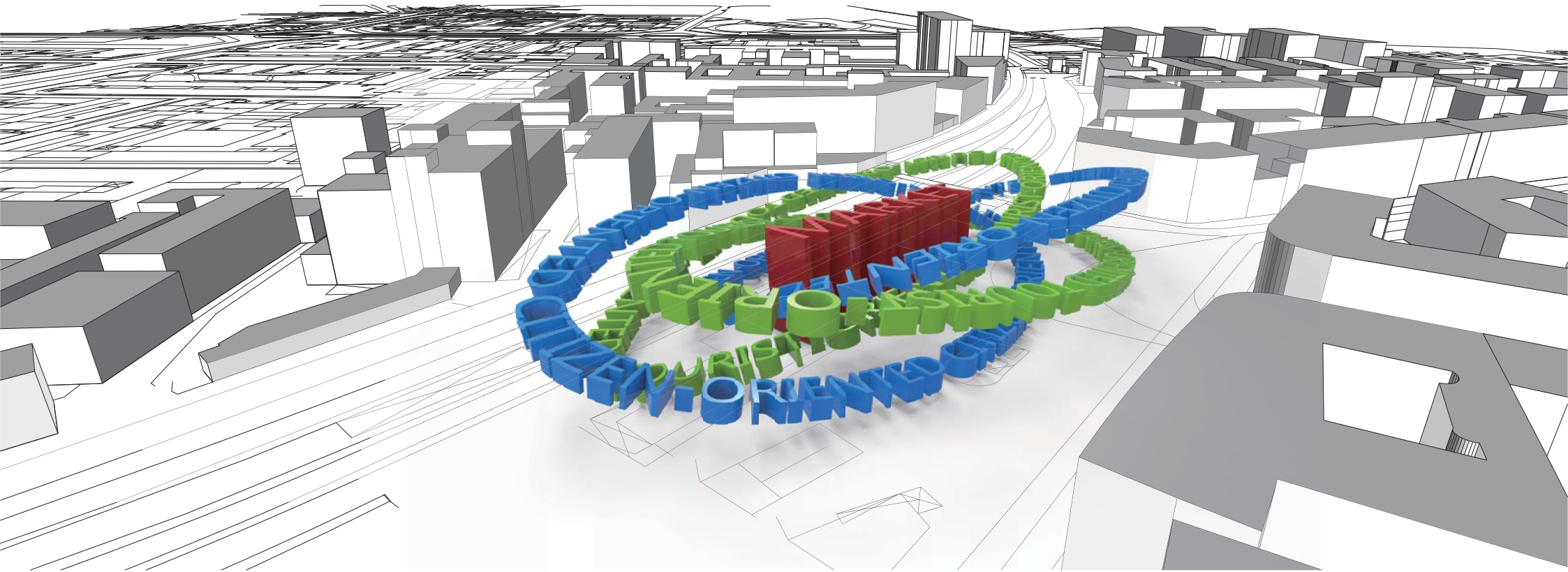

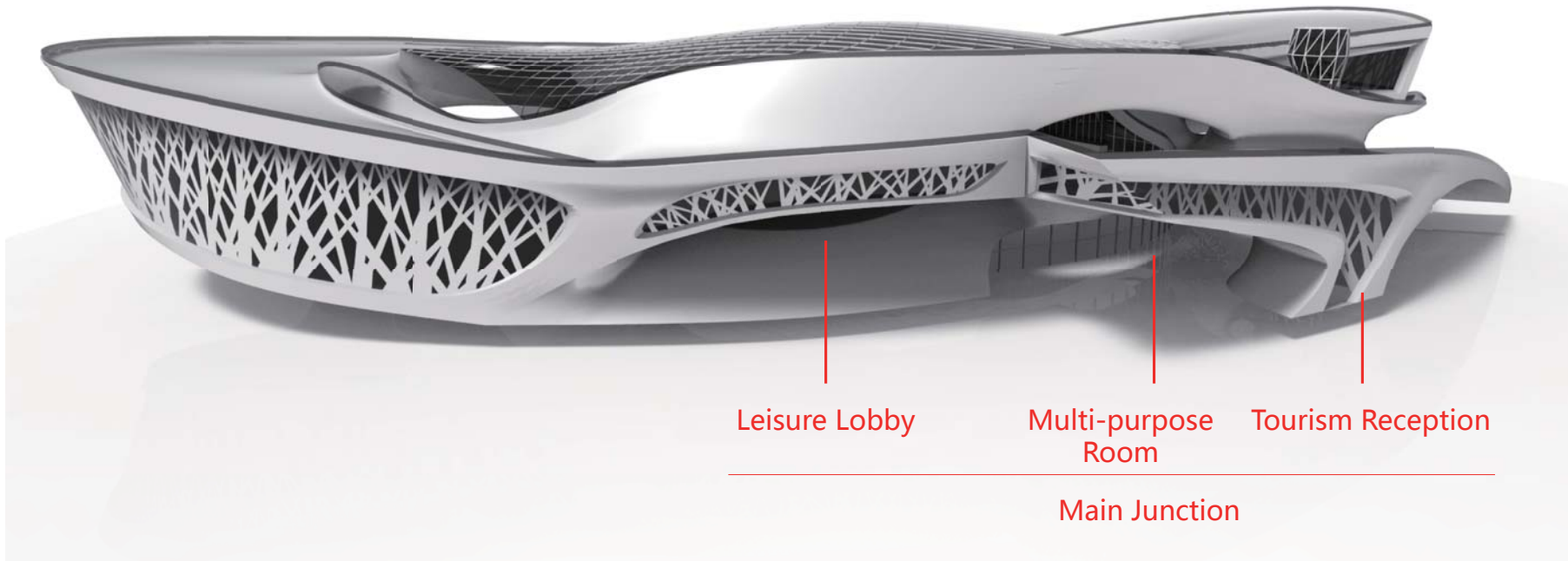

Leisure Lobby

Multi-purpose
Room

Tourism Reception
Room

Main Junction

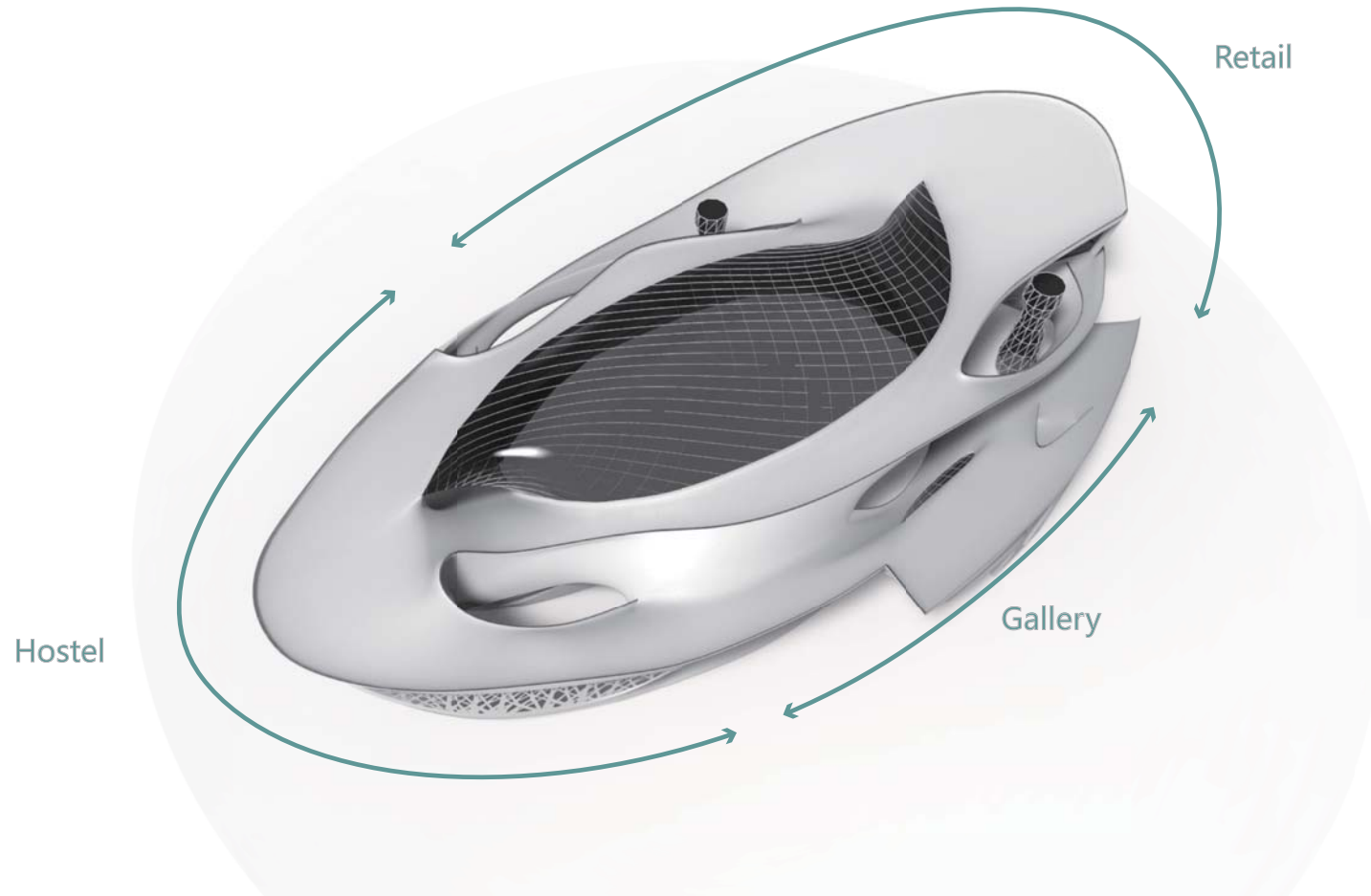

master plan

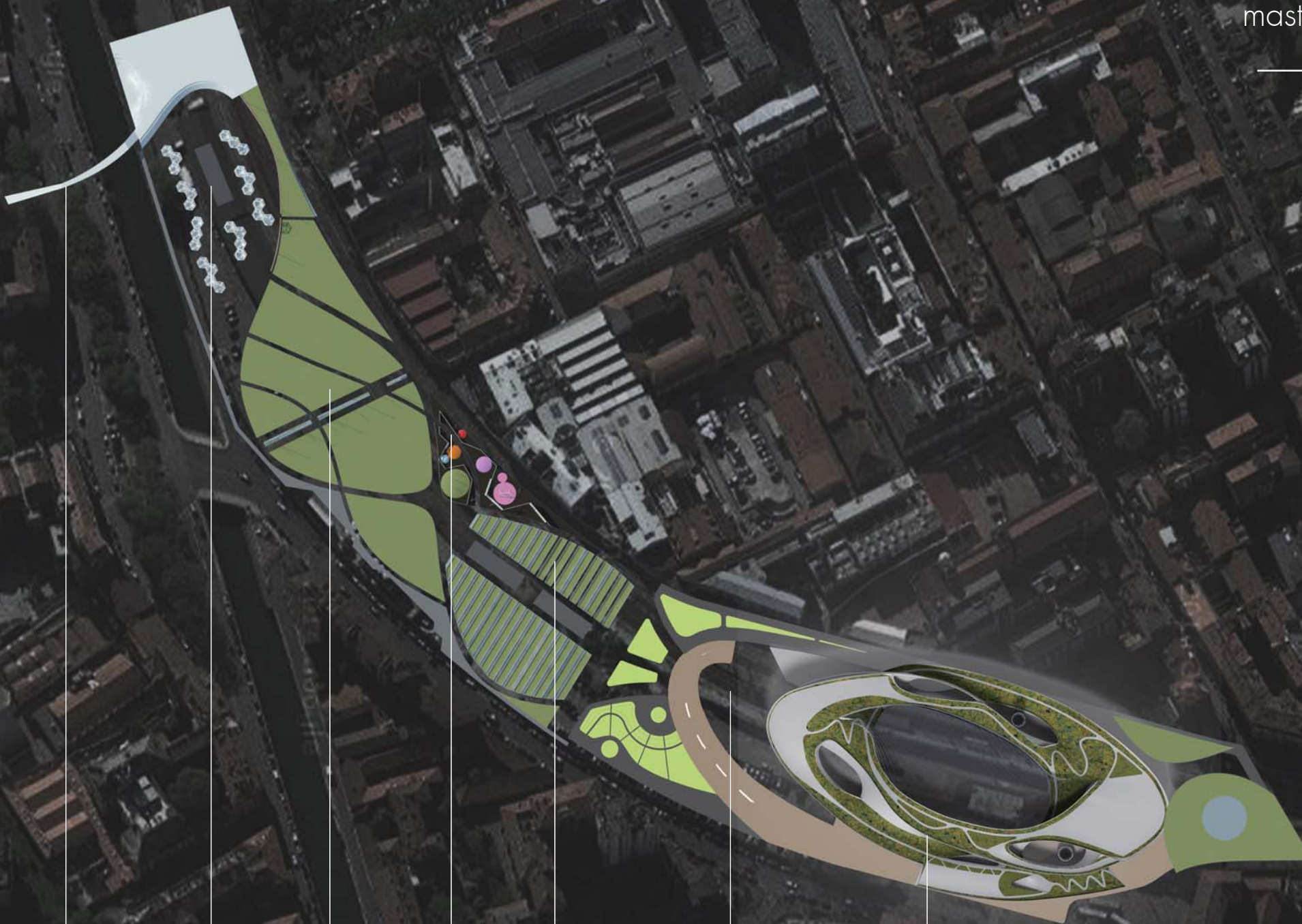
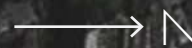

urban platform

open market

urban park

children
playground

agriculture
exhibition

sunken square

market
complex



children
playground



agriculture
exhibition

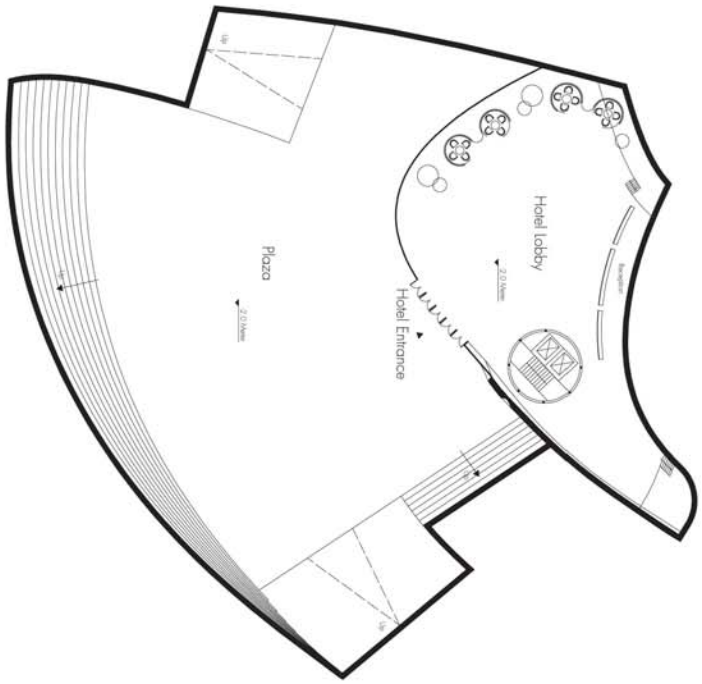

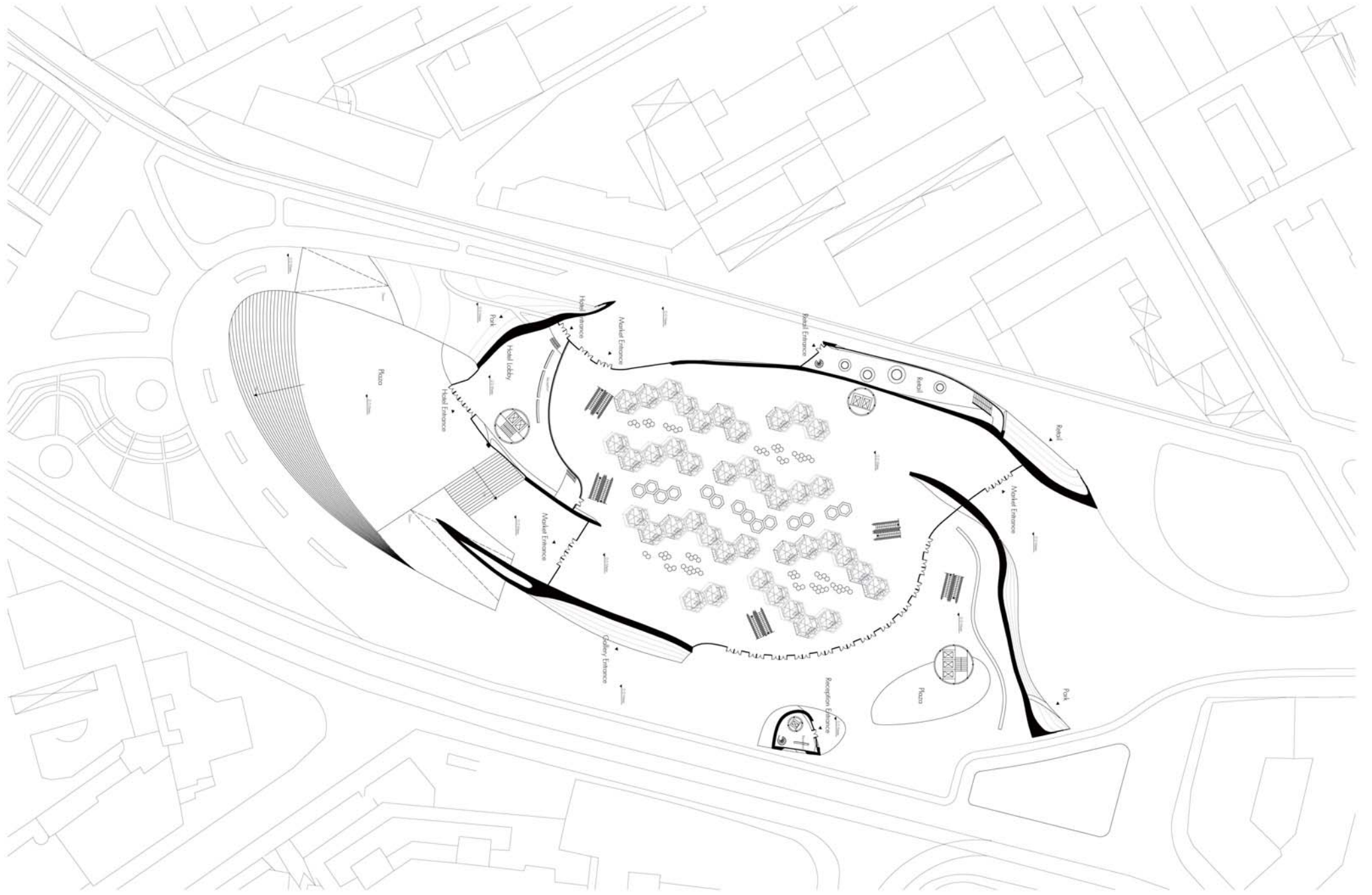

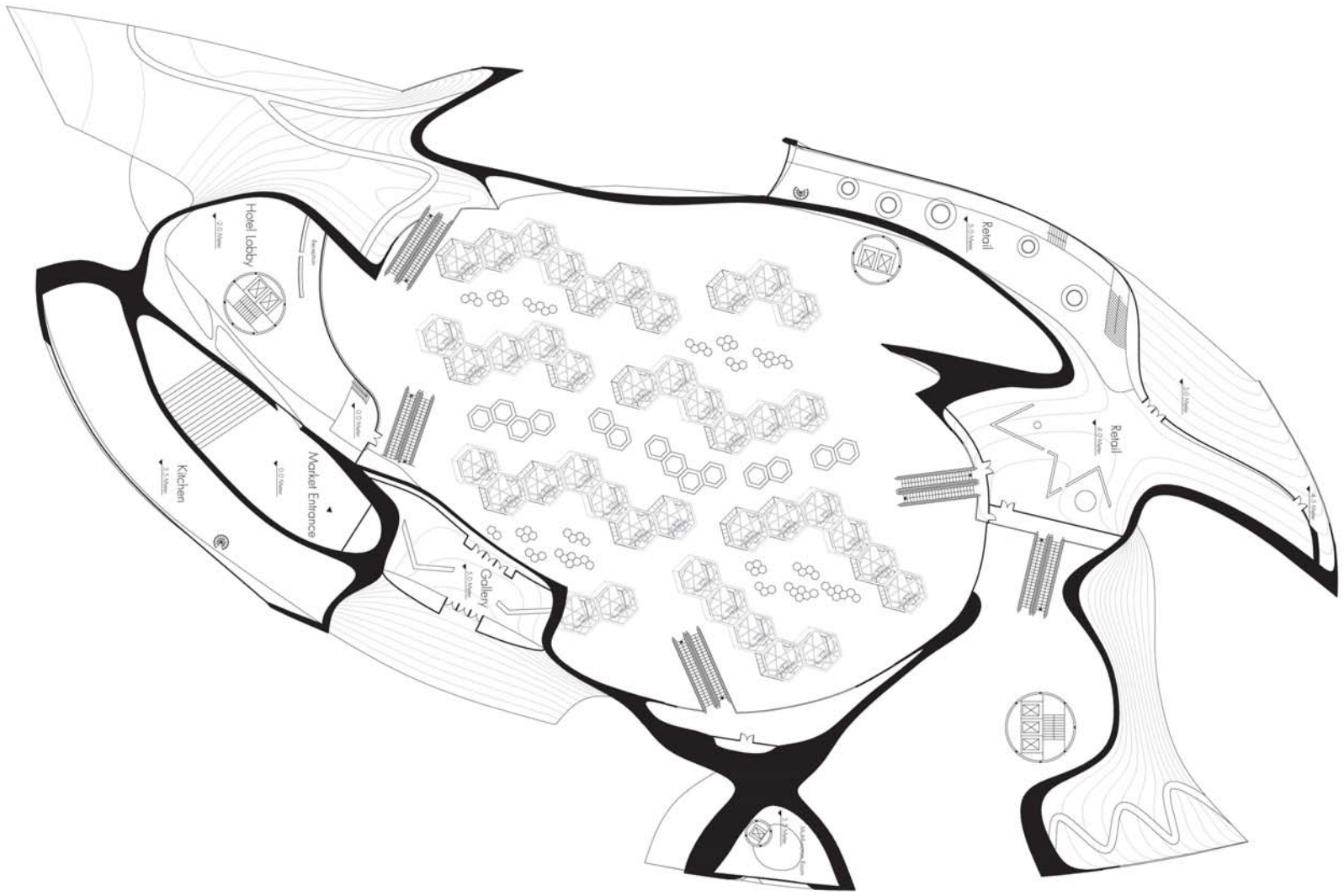

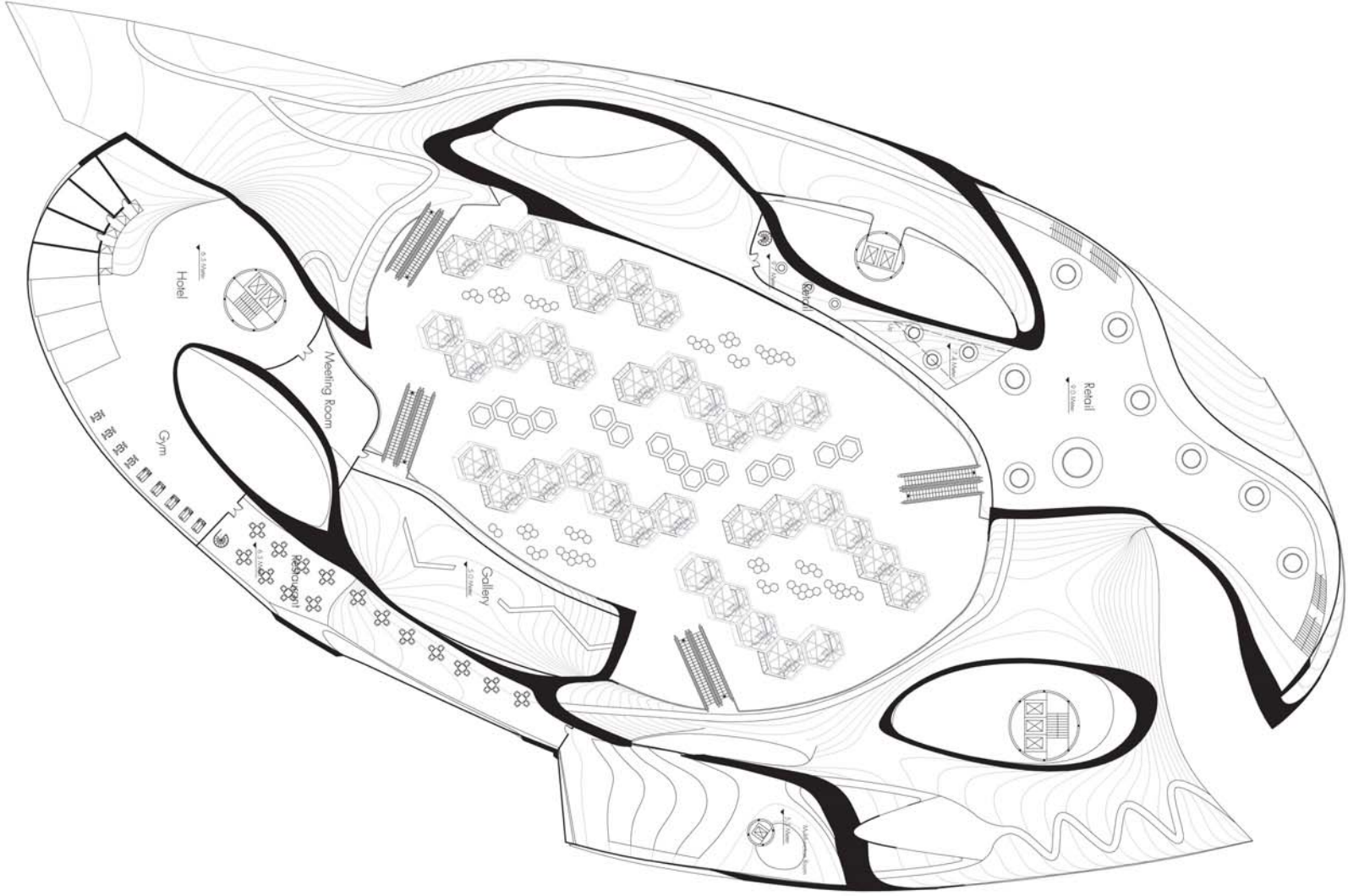

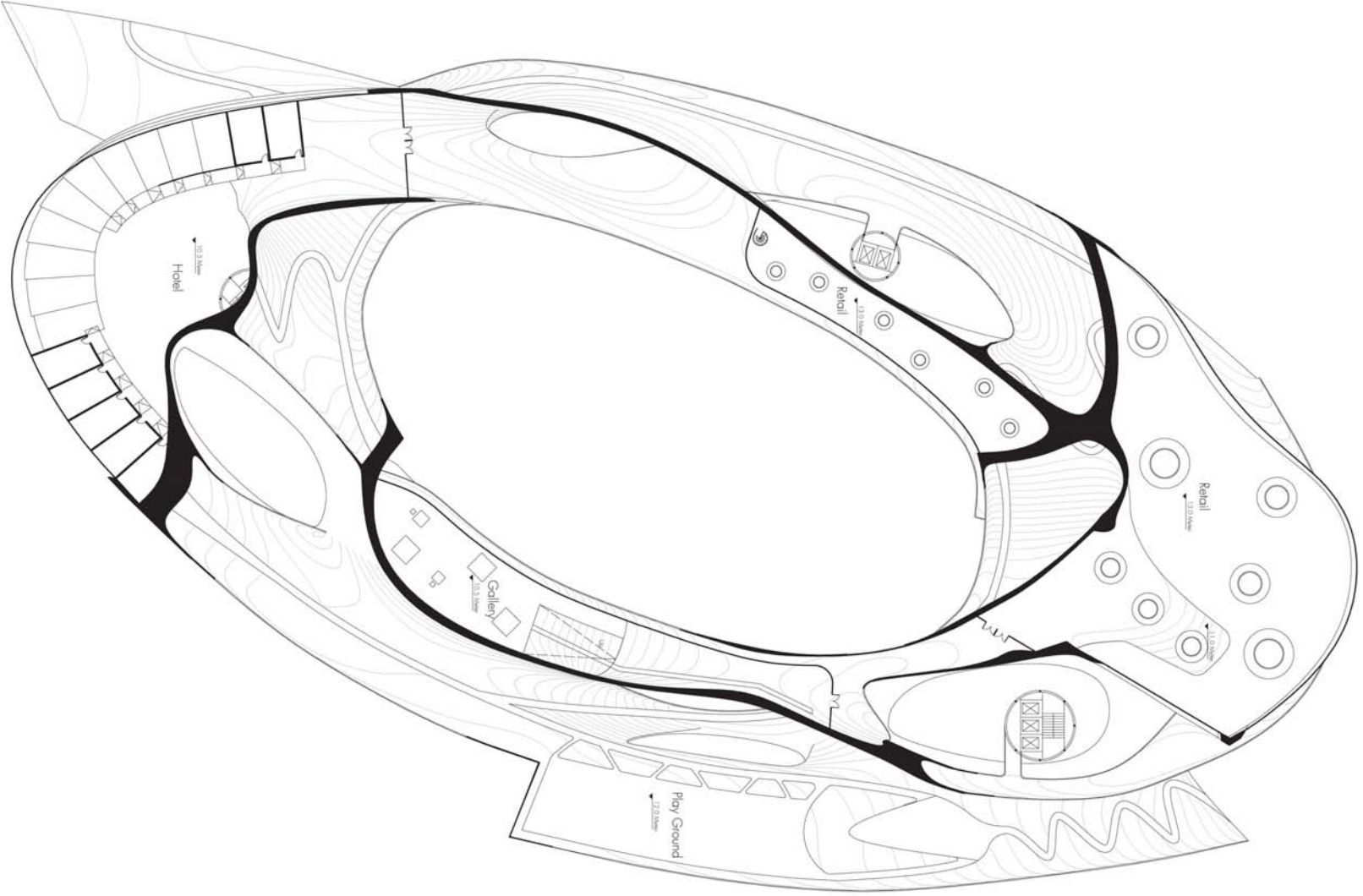

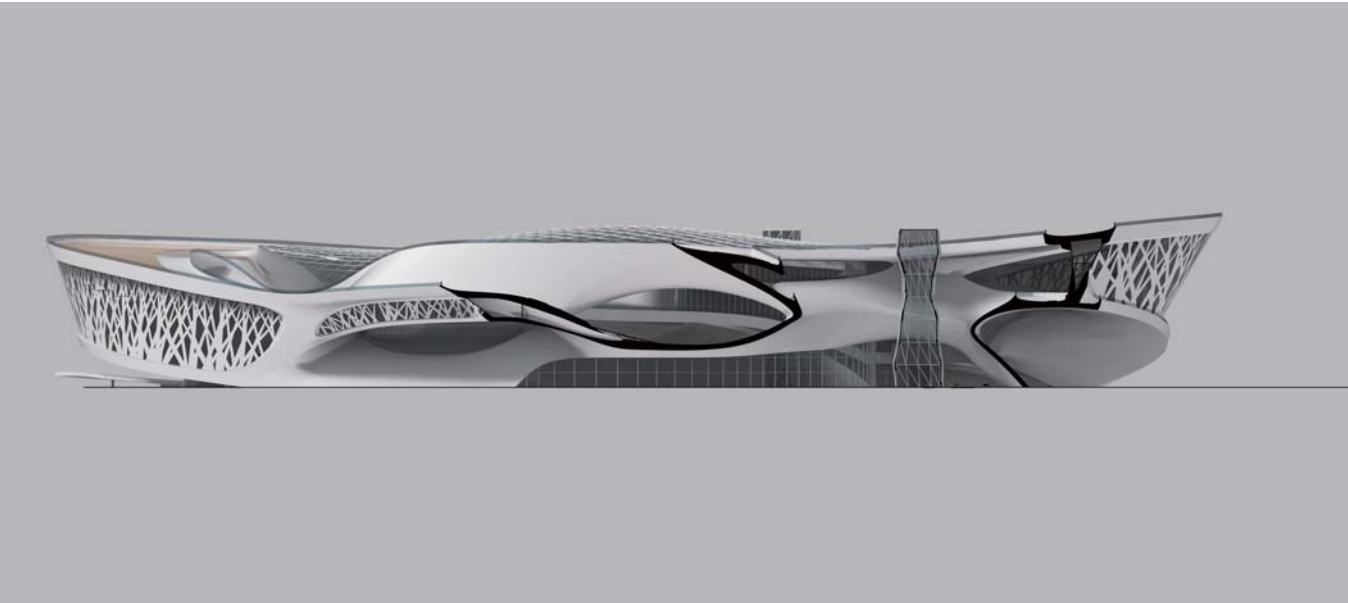
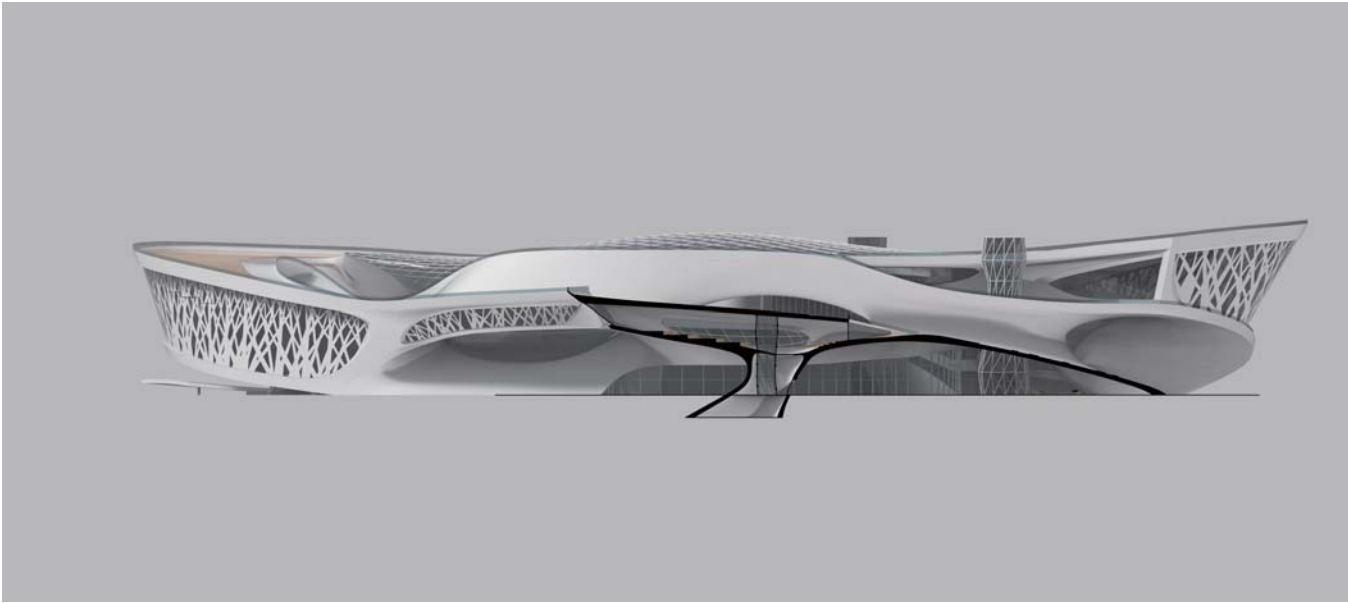

Sections

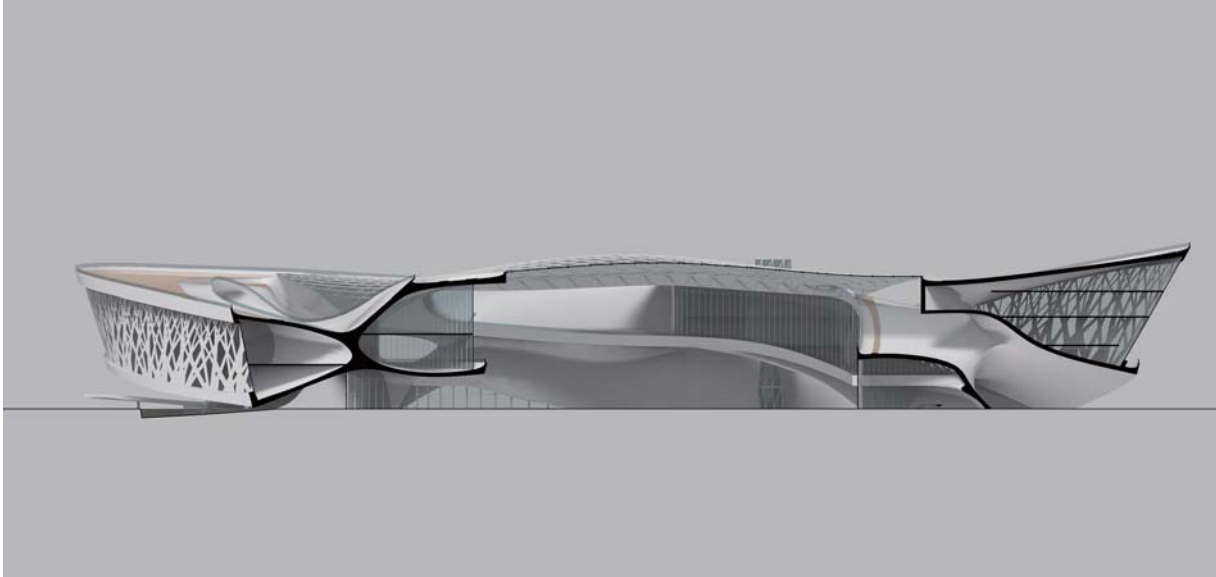
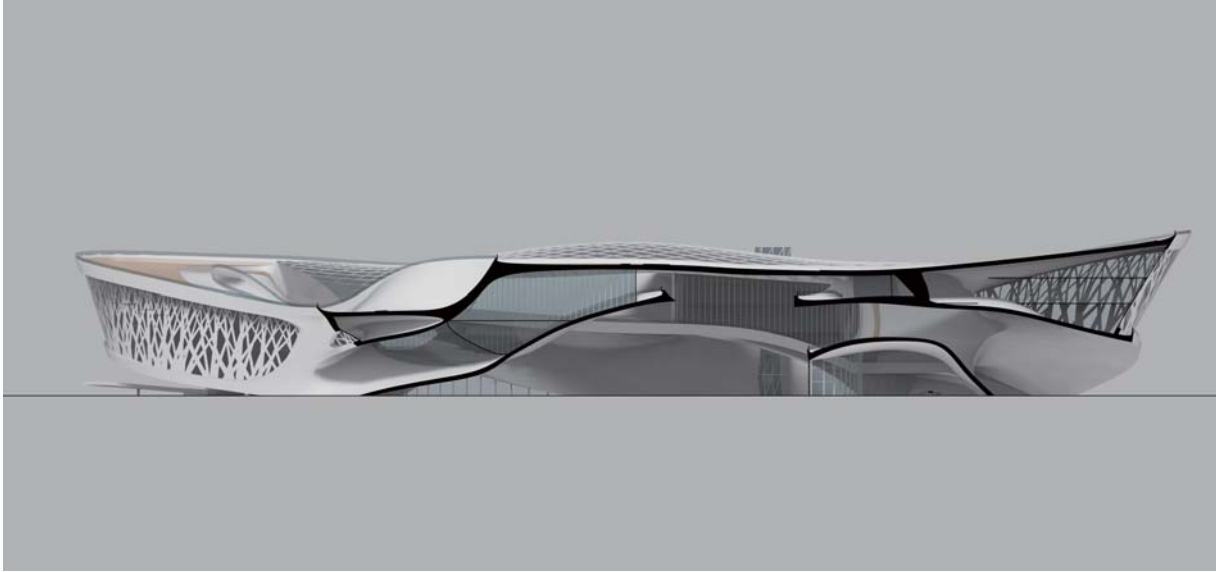

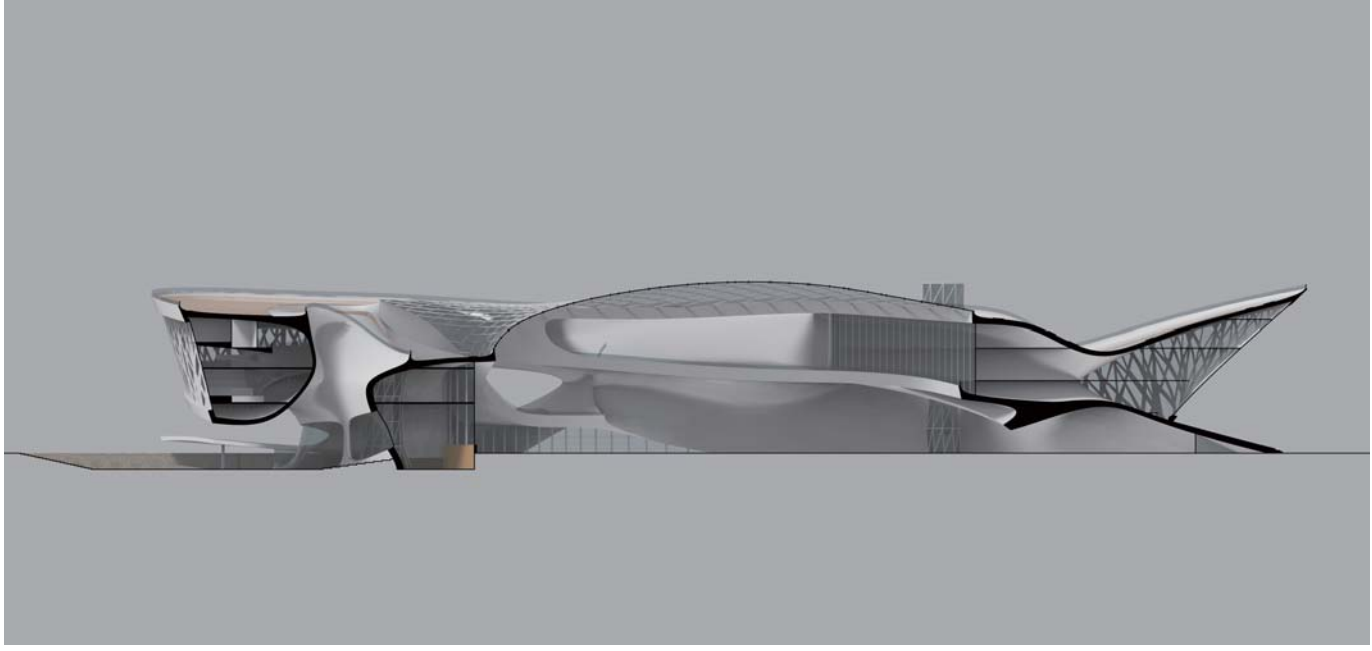
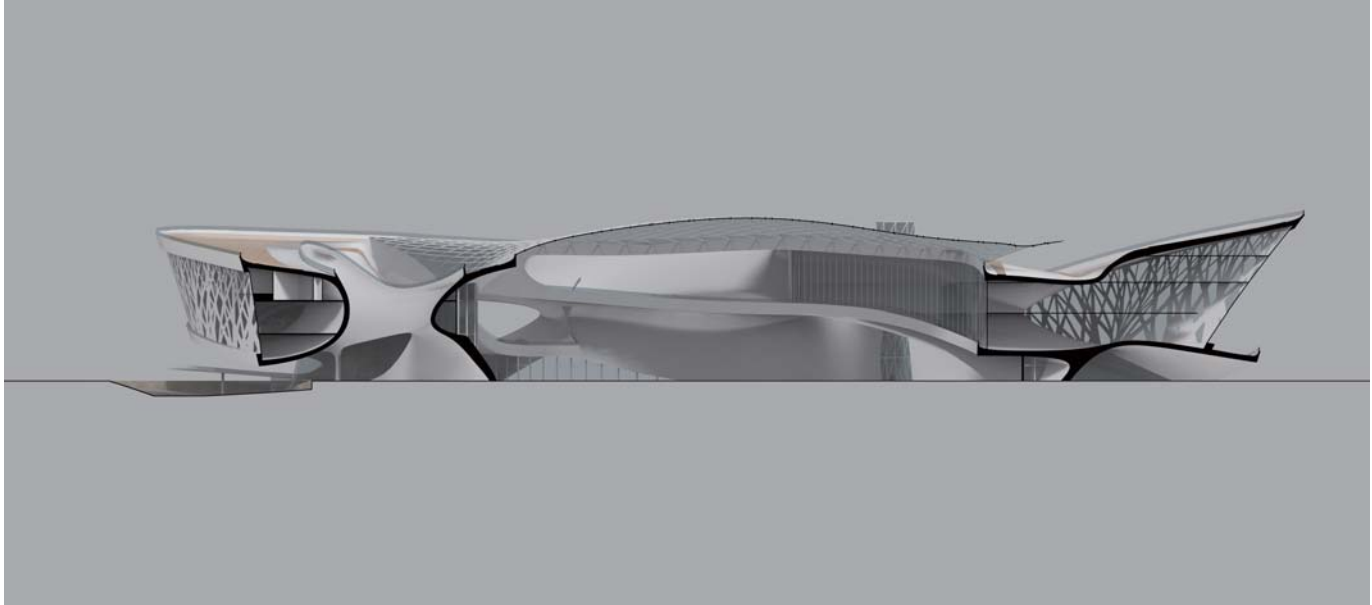

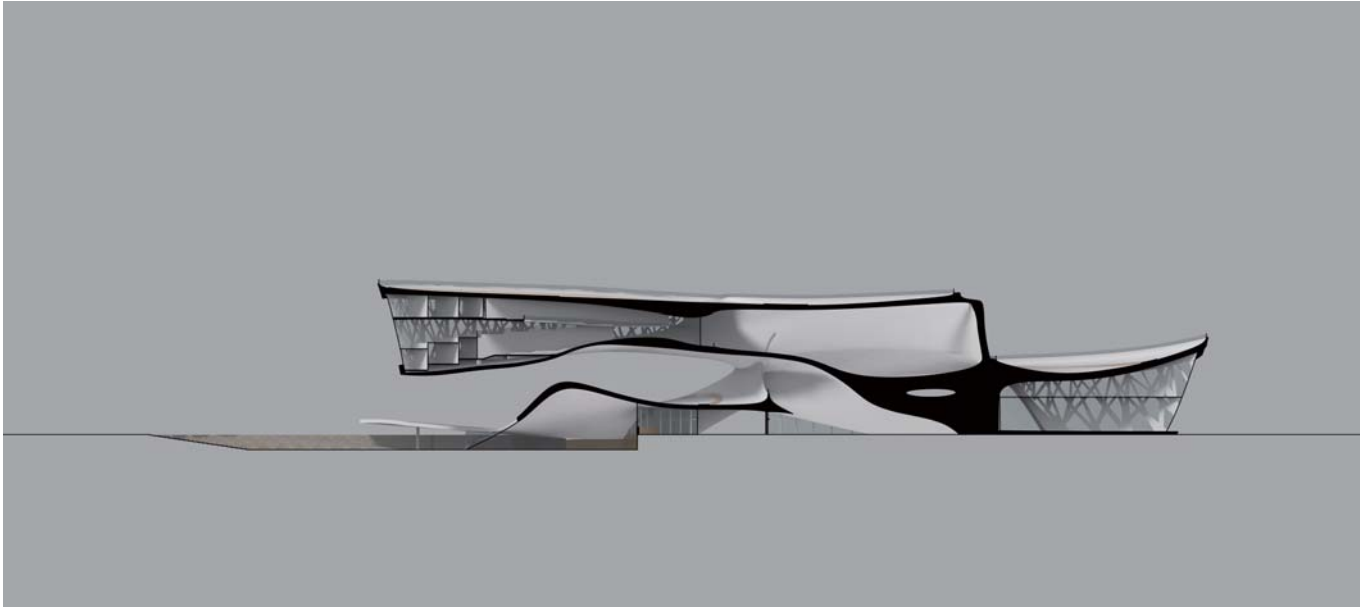
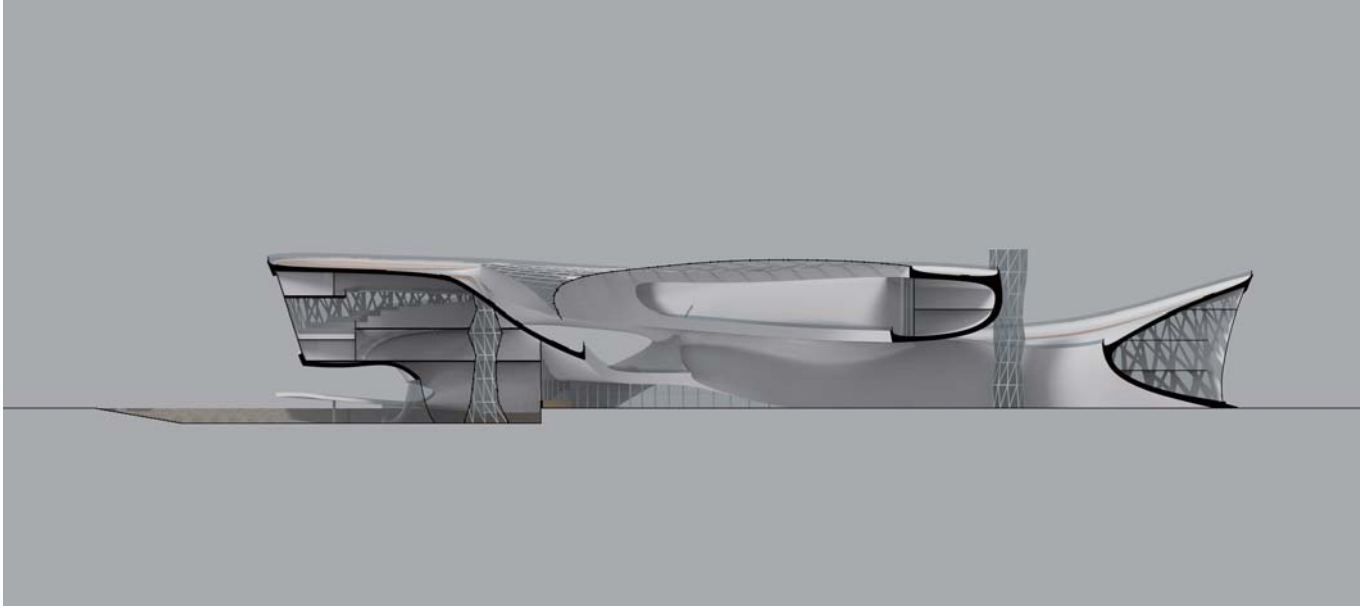

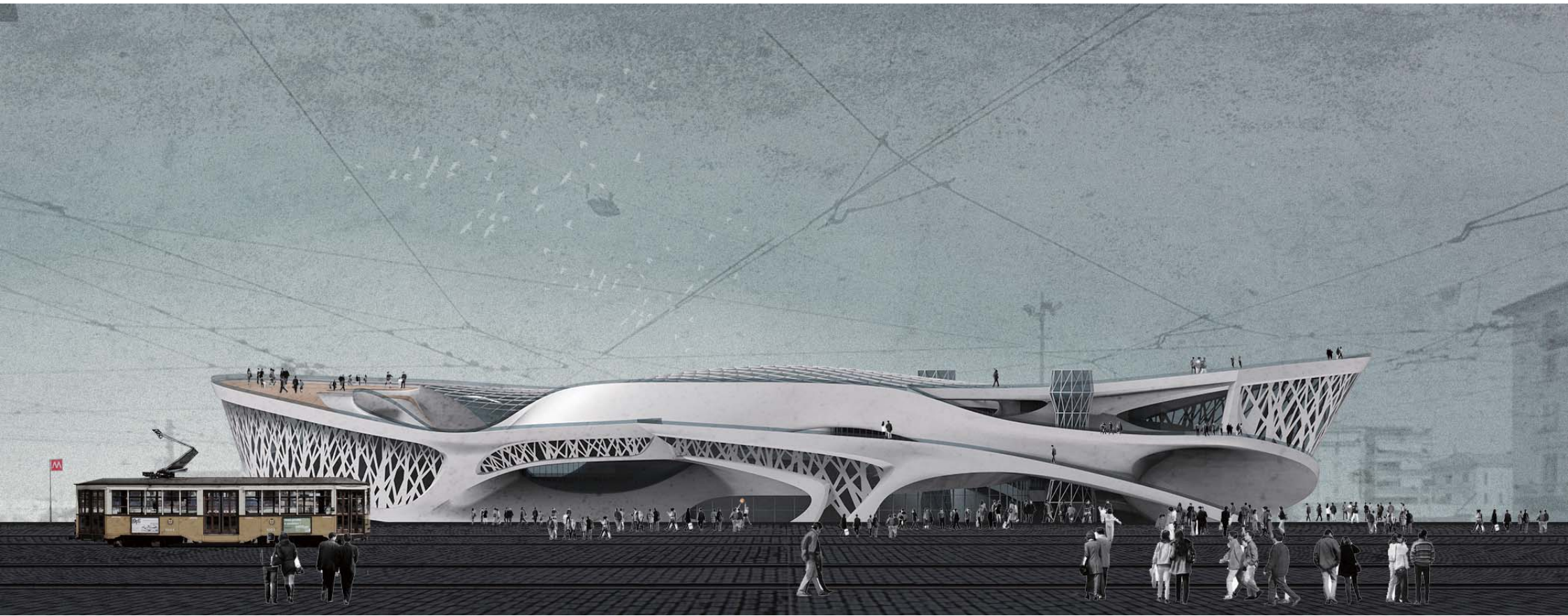

Facades east

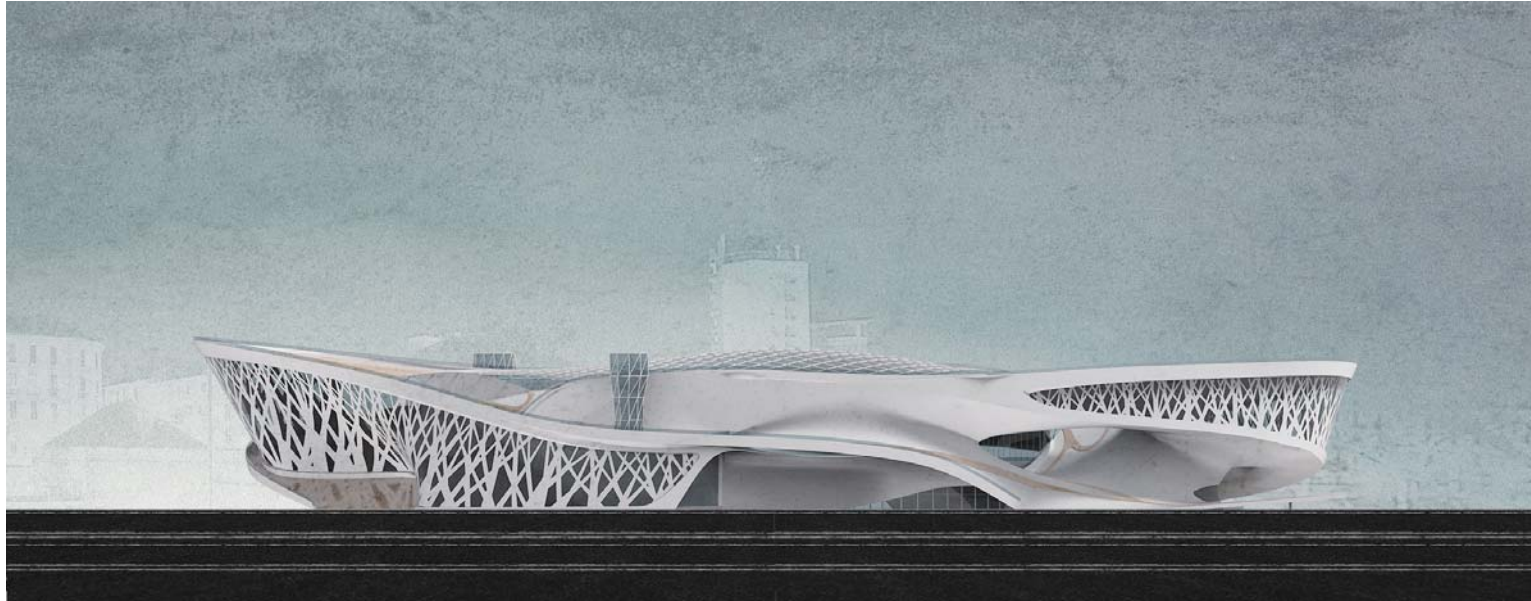

Facades west

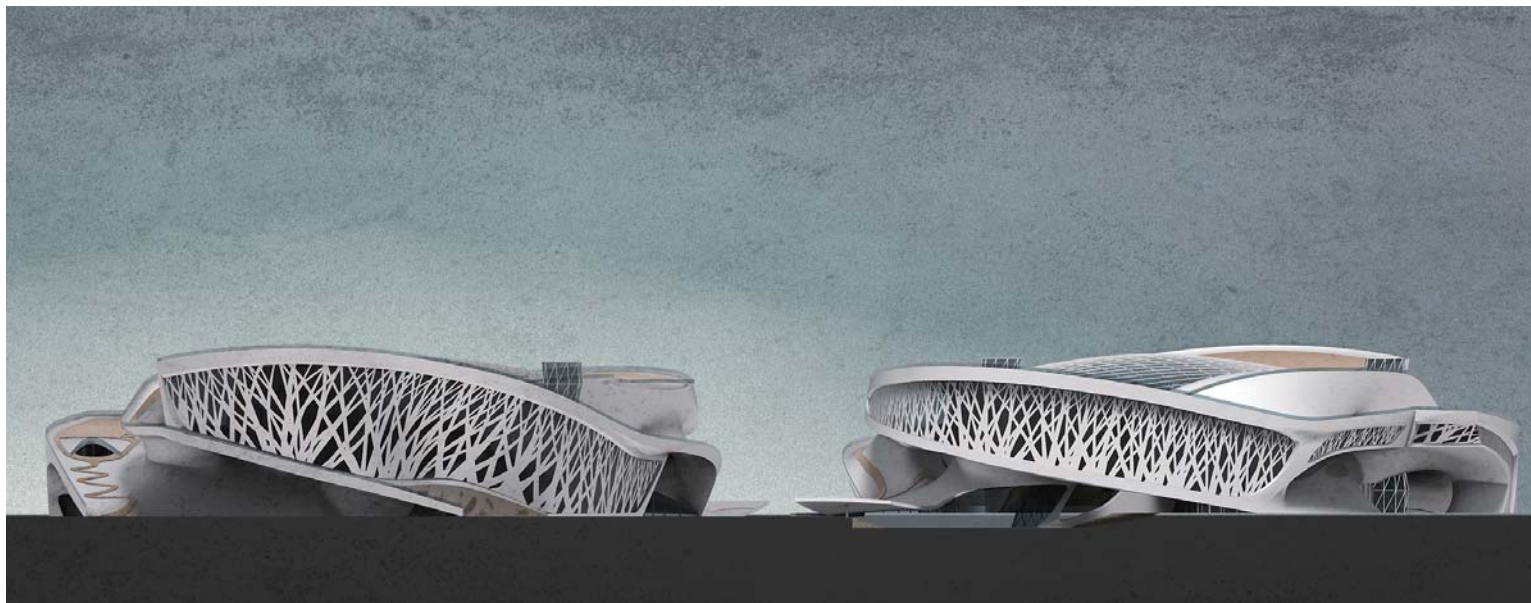

Facades north/south

