

CLOUD. THE INTERNET RESEARCH CENTER



Politecnico di Milano
Department of Architecture, Built Environment
and Construction Engineering
Polo regionale di Lecco



“Cloud”. The Internet Research Center

Relatore: Filippo Pagliani
Correlatore: Gabriele Masera

Master thesis of:

Alontseva Ksenia
Voronova Kseniia

INDEX

1. Urban design

- 1.1 Masterplan
- 1.2 Sections
- 1.3 Flood prevention measures

2. Architectural design

- 2.1 Plan of Underground level
- 2.2 Plan of Ground level
- 2.3 Plan of First level
- 2.4 Plan of Second level
- 2.5 Plan of Third level
- 2.6 Plan of the Fourth level
- 2.7 Plan of the roof
- 2.8 Section A-A
- 2.9 Section B-B
- 2.10 Facade 1 - 13
- 2.11 Facade A' - J
- 2.12 Facade 13 - 1
- 2.13 Facade J - A'
- 2.14 View from the river
- 2.15 View from the waterfront
- 2.16 View on the main facade from the river
- 2.17 View from the Open square
- 2.18 View on the entrance

3. Technological design

- 3.1 Blow up 01
- 3.2 Blow up 02
- 3.3 Details. 1
- 3.4 Details. 2
- 3.5 Details. 3
- 3.6 Schematic design. Winter strategies
- 3.7 Schematic design. Summer strategies
- 3.8 Sequence of construction process
- 3.9 Sequence of construction process
- 3.10 Details of the connections of main elements

4. Structural design

- 4.1 Structural plan of foundation
- 4.2 Structural plan of Ground level on +5 800
- 4.3 Structural plan of First level on + 10 300
- 4.4 Structural plan of Second level on + 14 630
- 4.5 Structural plan of Third level on +18 800, +22 900
- 4.6 Structural plan of space truss





Cross section of the territory



Longitudinal section of the territory



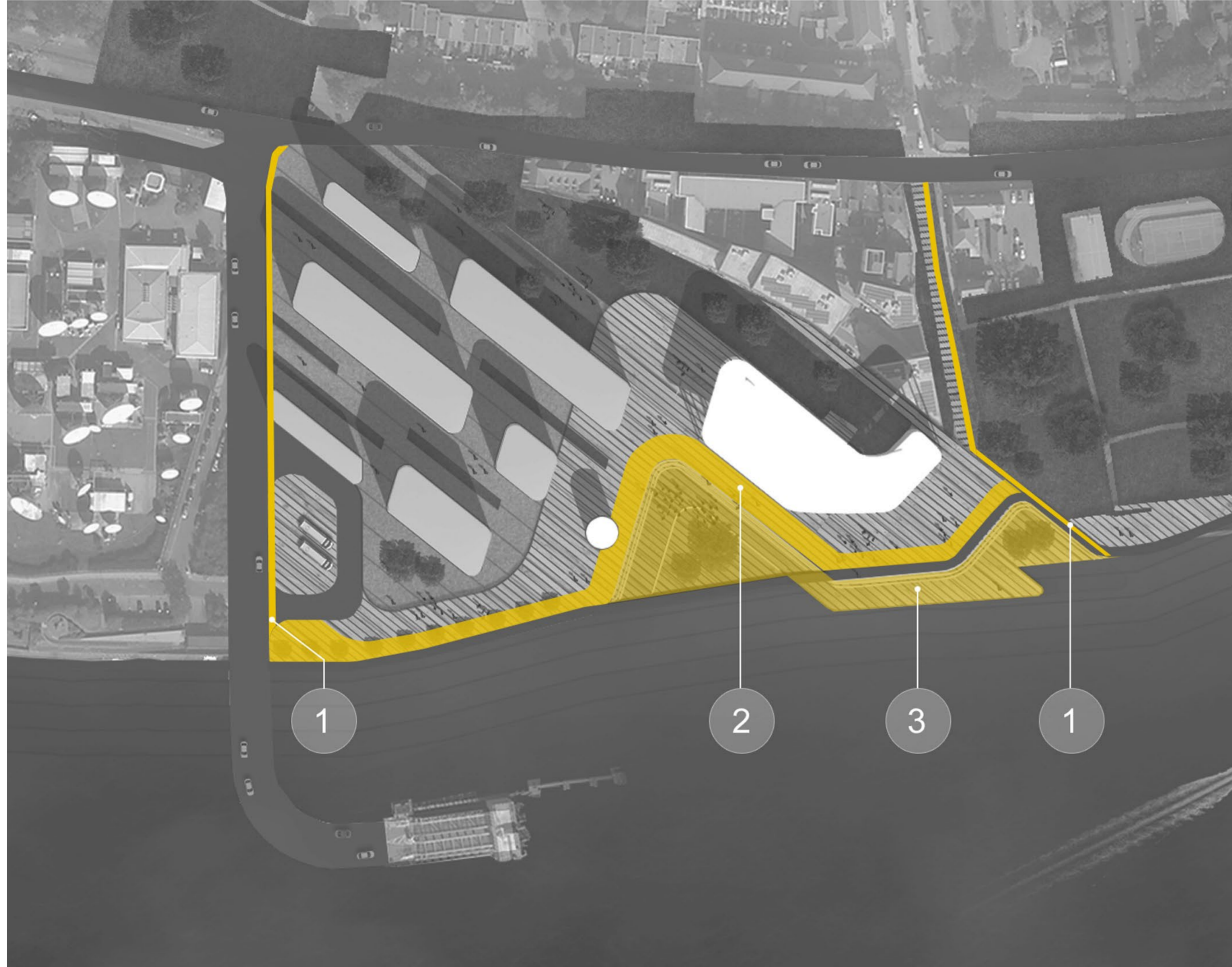

1. Movable barriers

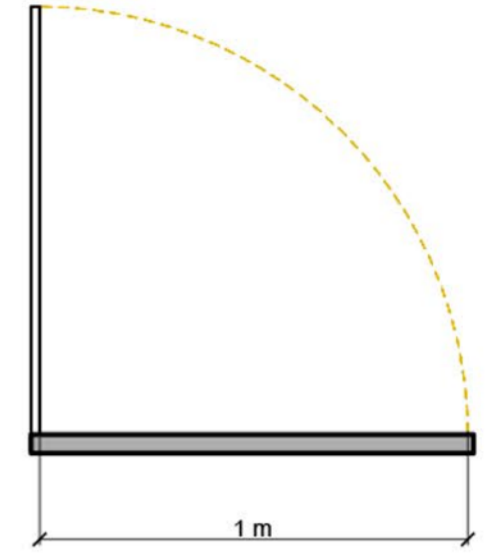

2. Artificial slope 3%

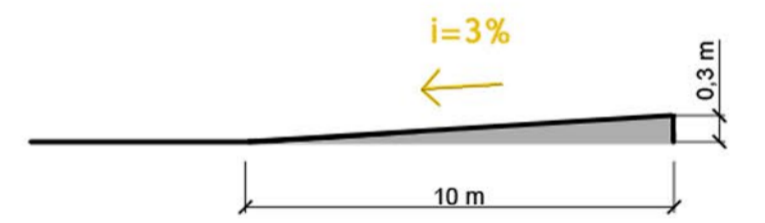

3. Stairs



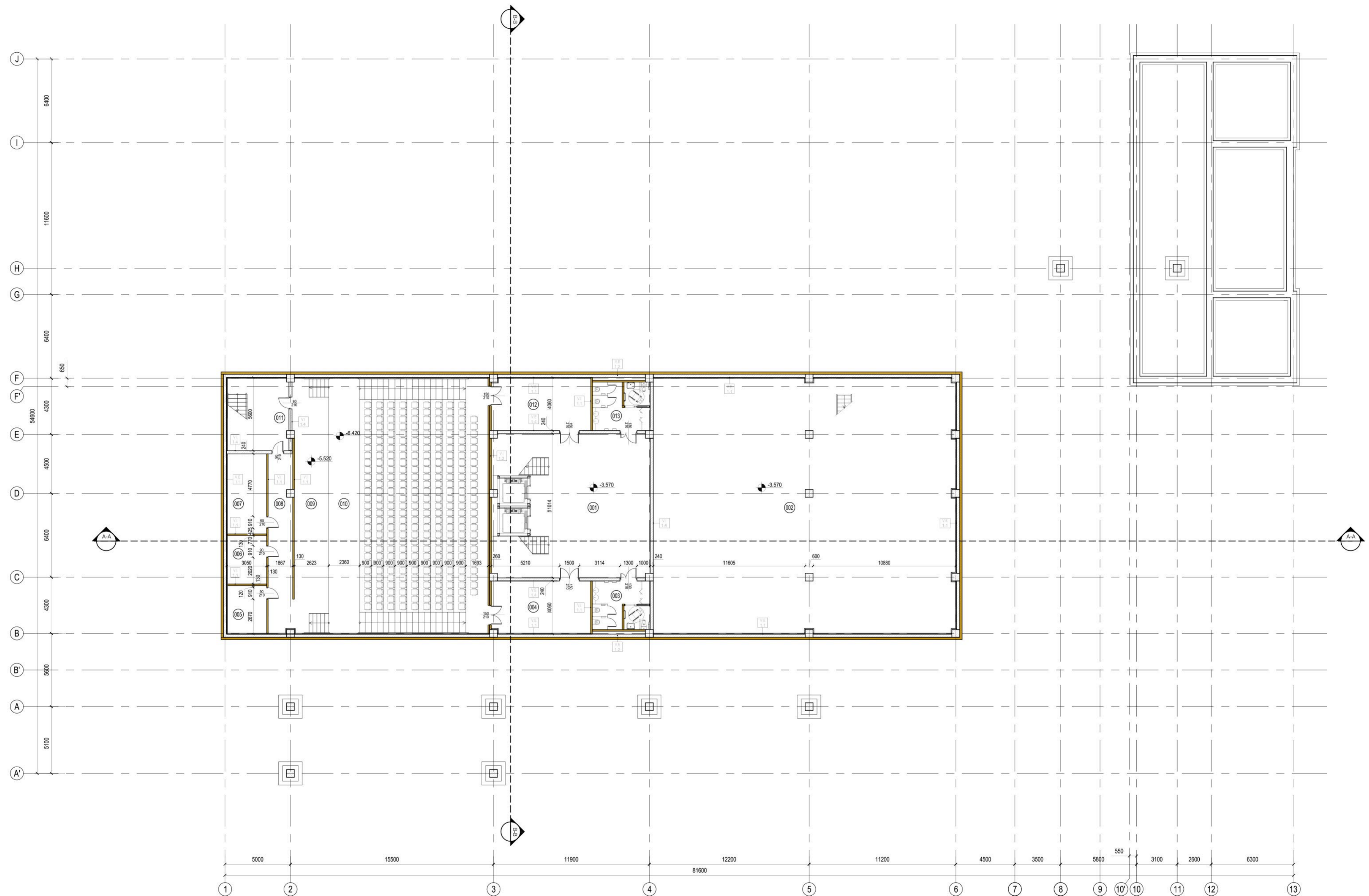

LEGEND

001	Foyer	119.0 mm ²	006	Changing room	11.0 mm ²	011	Emergency staircase	20.8 mm ²
002	Technical space	447.8 mm ²	007	Changing room	18.2 mm ²	012	Corridor	30.1 mm ²
003	Restrooms	16.3 mm ²	008	Corridor	20.5 mm ²	013	Restrooms	10.3 mm ²
004	Corridor	30.1 mm ²	009	Stage	56.7 mm ²	Total		1029.2 mm ²
005	Changing room	10.8 mm ²	010	Forum	237.6 mm ²			



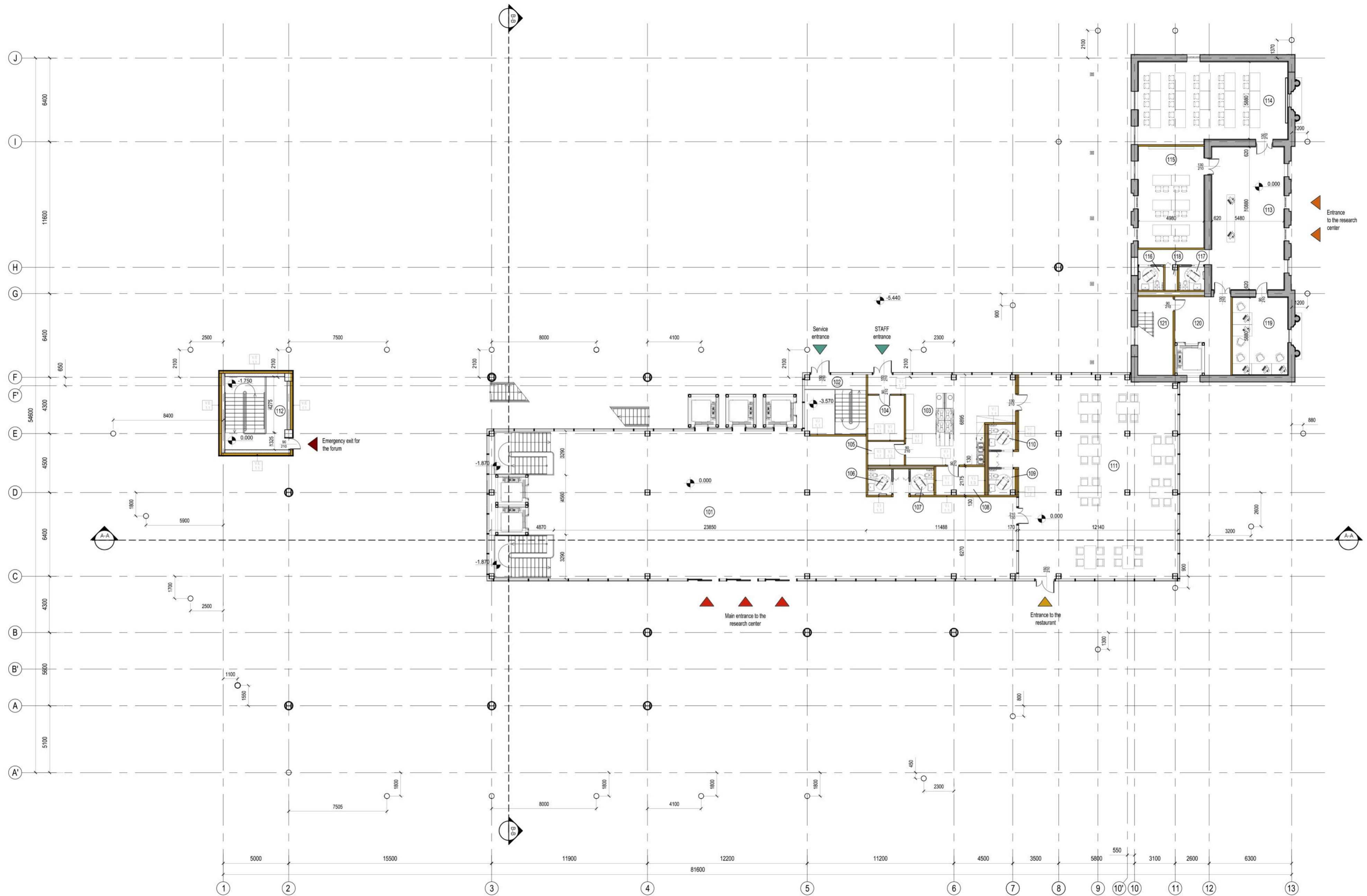

LEGEND

101	Foyer / Hall	382.1 mm ²	106	Restrooms	3.6 mm ²	111	Dining hall	188.2 mm ²	116	Restrooms	3.5 mm ²	121	Emergency staircase	16.4 mm ²
102	Technical entrance	212.2 mm ²	107	Restrooms	3.6 mm ²	112	Emergency staircase	26.4 mm ²	117	Restrooms	3.5 mm ²	Total		1047.9 mm ²
103	Kitchen	54.2 mm ²	108	Storeroom	7.9 mm ²	113	Hall	66.7 mm ²	118	Storeroom	1.7 mm ²			
104	Storeroom	9.6 mm ²	109	Restrooms	3.9 mm ²	114	Work station	6.9 mm ²	119	Workstation	24.9 mm ²			
105	Storeroom	5.0 mm ²	110	Restrooms	3.9 mm ²	115	Work station	38.7 mm ²	120	Hall	20.1 mm ²			





LEGEND

201	Open square	491.2 mm ²	206	Storeroom	15.9 mm ²	211	Restrooms	16.7 mm ²	216	IT suit	36.5 mm ²
202	Hall	14.8 mm ²	207	Open studio	141.6 mm ²	212	Working area	78.6 mm ²	217	Restrooms	3.7 mm ²
203	Open studio	109.5 mm ²	208	Open studio	109.9 mm ²	213	Conference room	37.4 mm ²	218	Restrooms	3.7 mm ²
204	Storeroom	10.1 mm ²	209	Hall	37.6 mm ²	214	Emergency staircase	16.2 mm ²	219	Hall	14.9 mm ²
205	Hall	17.3 mm ²	210	Restrooms	15.8 mm ²	215	Hall	7.9 mm ²	220	IT suit	101.4 mm ²
									Total	1280.7 mm ²	



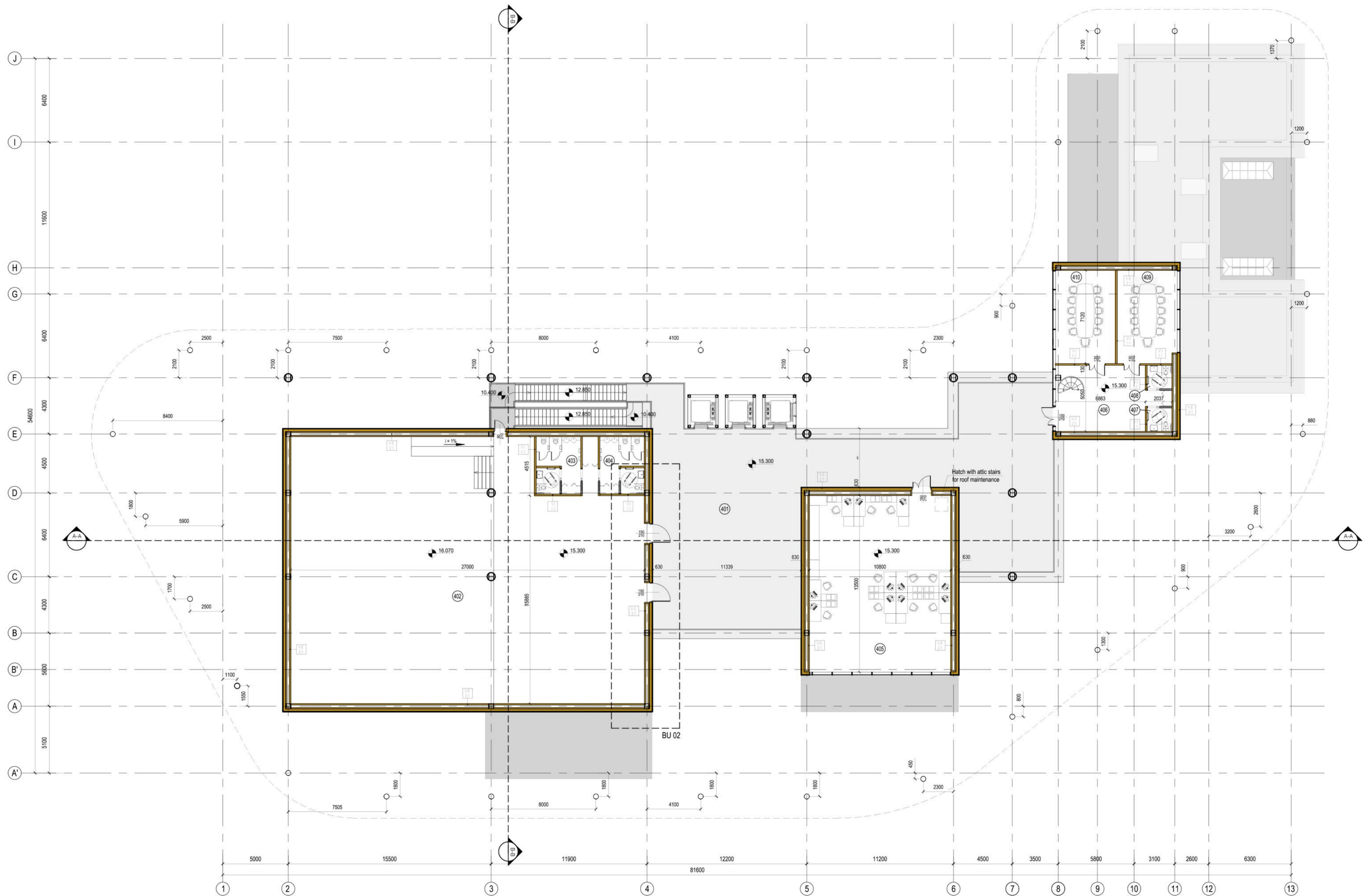

LEGEND

401	Open square	364.0 mm ²	406	Hall	36.9 mm ²
402	Exhibition area	518.3 mm ²	407	Restrooms	3.5 mm ²
403	Restrooms	14.9 mm ²	408	Restrooms	3.5 mm ²
404	Restrooms	14.9 mm ²	409	Conference room	32.3 mm ²
405	Work area	145.9 mm ²	410	Conference room	326 mm ²
			Total		1166.8 mm ²



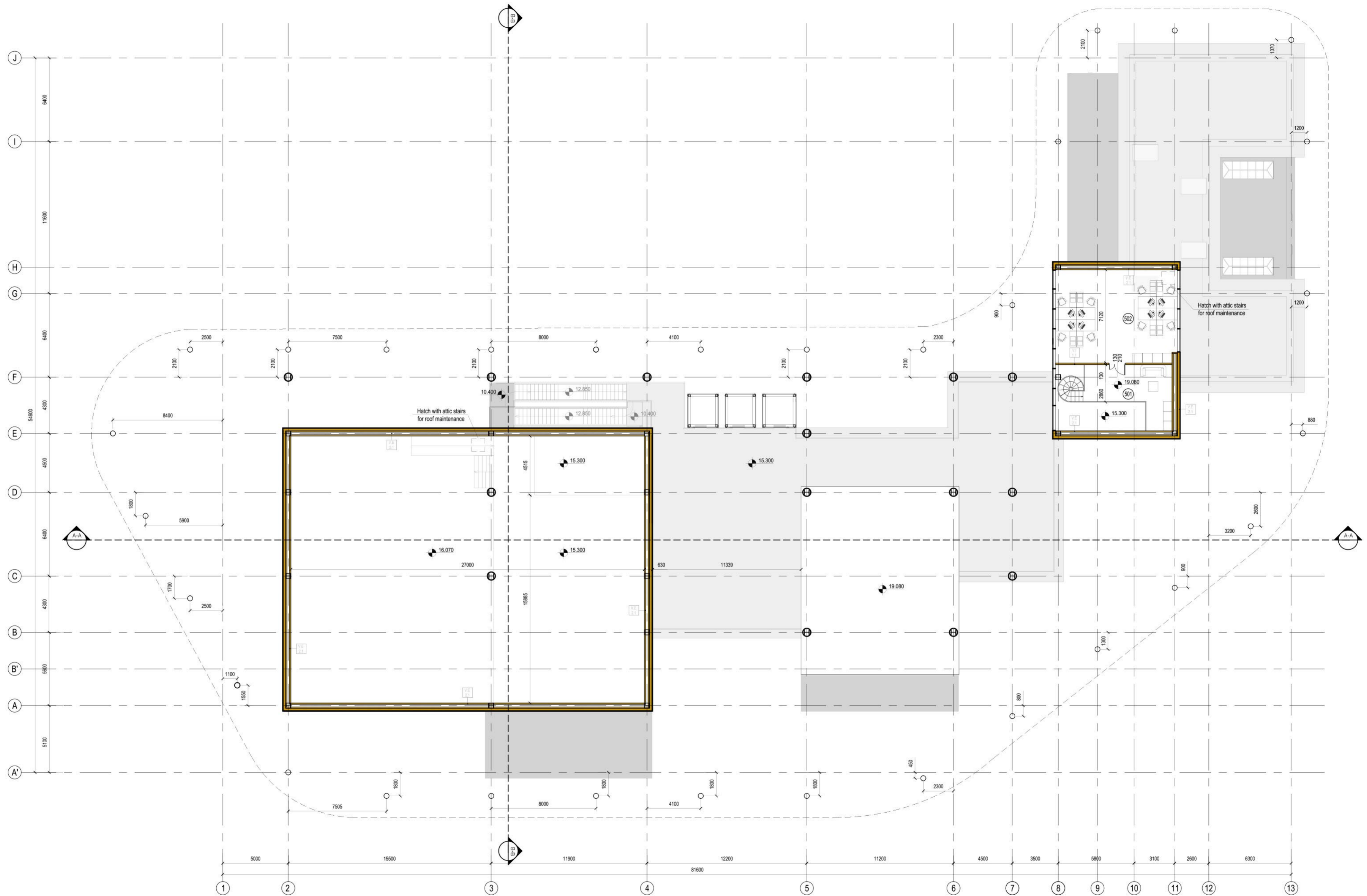

LEGEND

501	Hall	26.3 mm ²
502	Working area	65.9 mm ²
	Total	92.2 mm ²



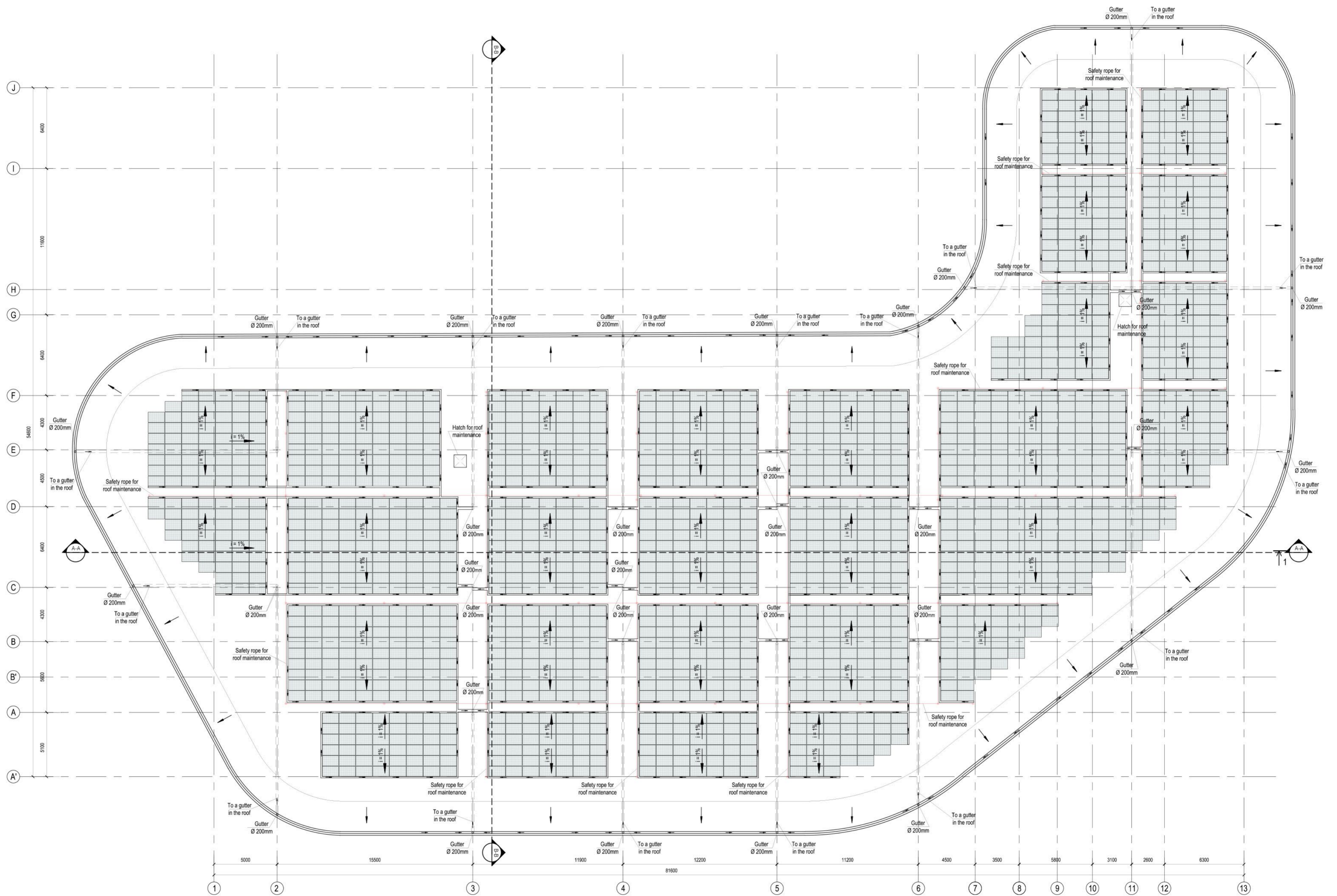

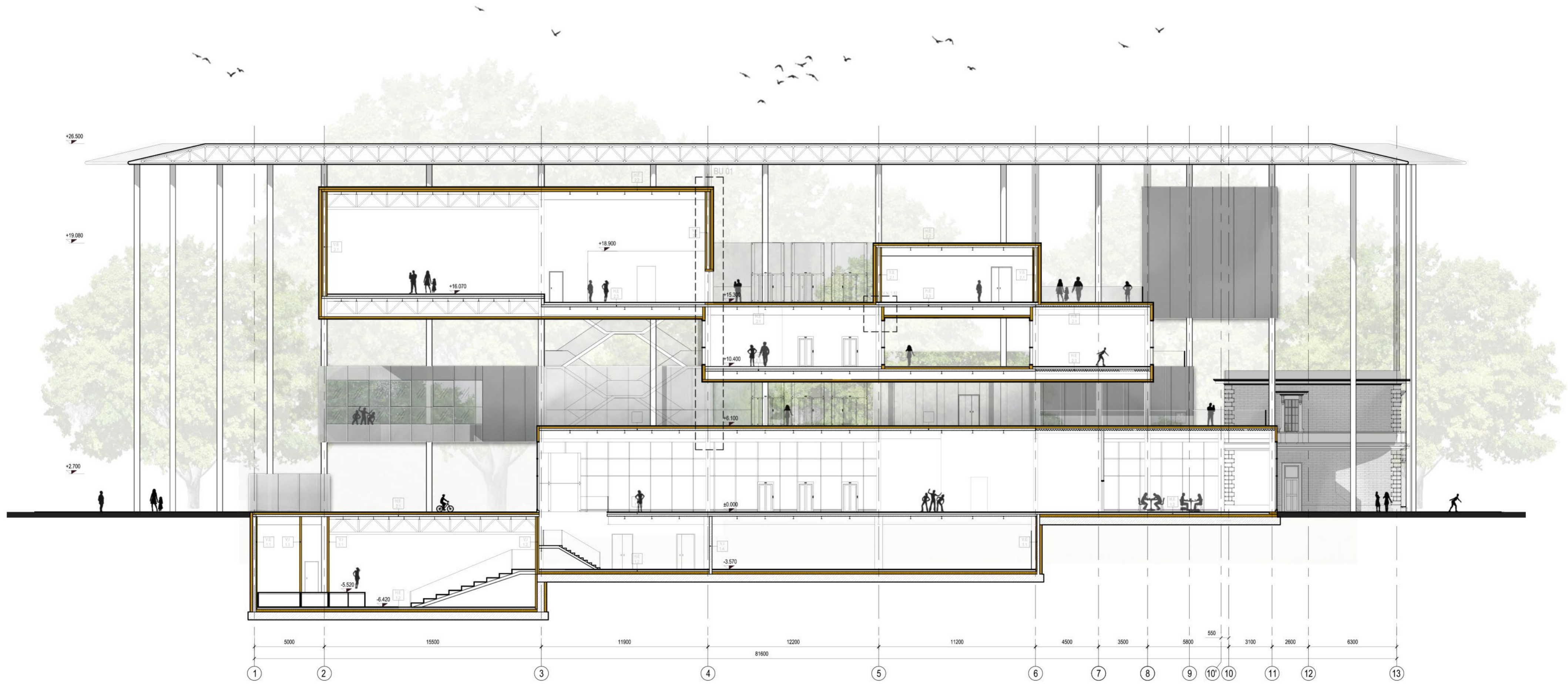





81600

1

13



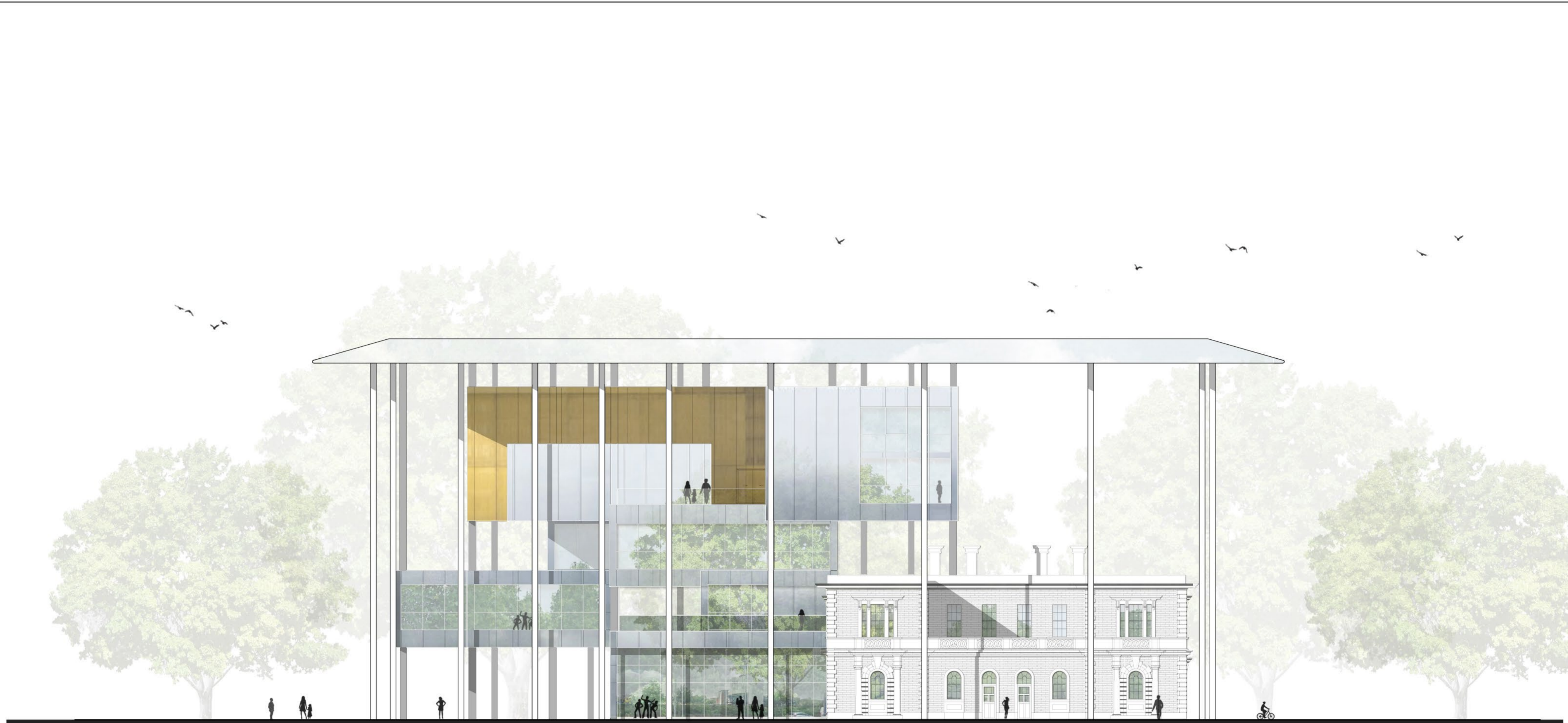

A' 54600 J



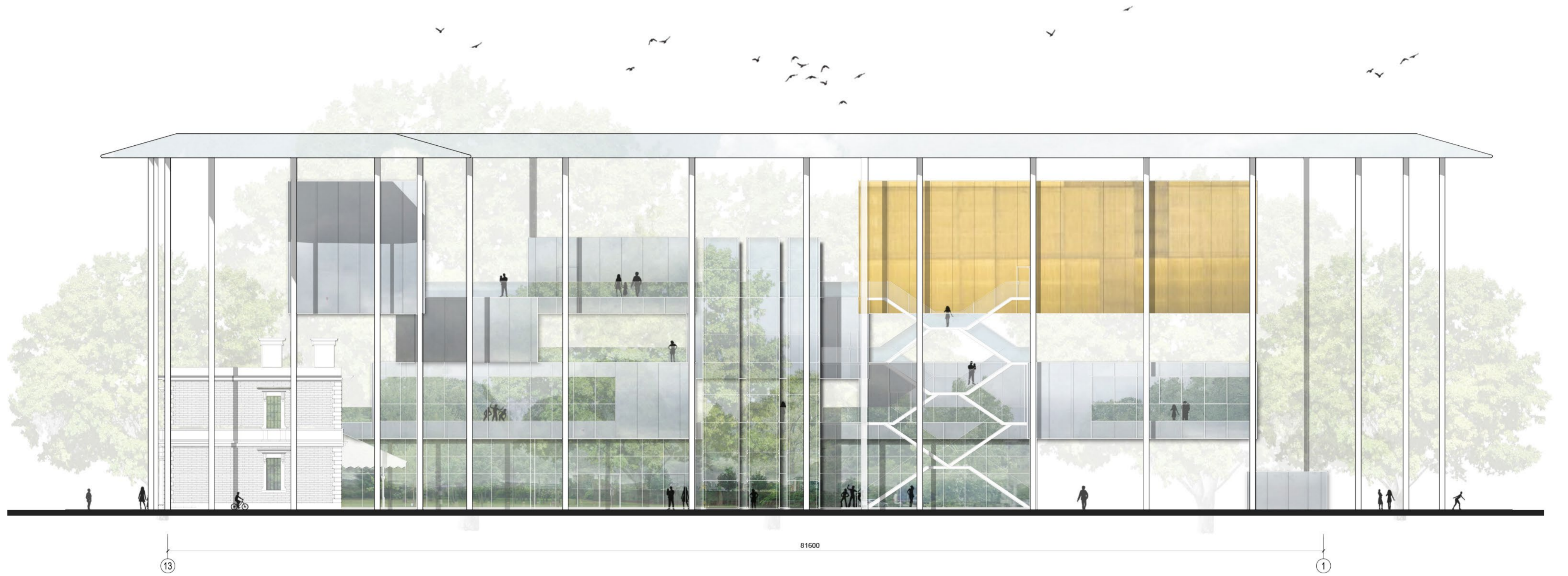







Politecnico di Milano

View from the waterfront

Scale -

2.15







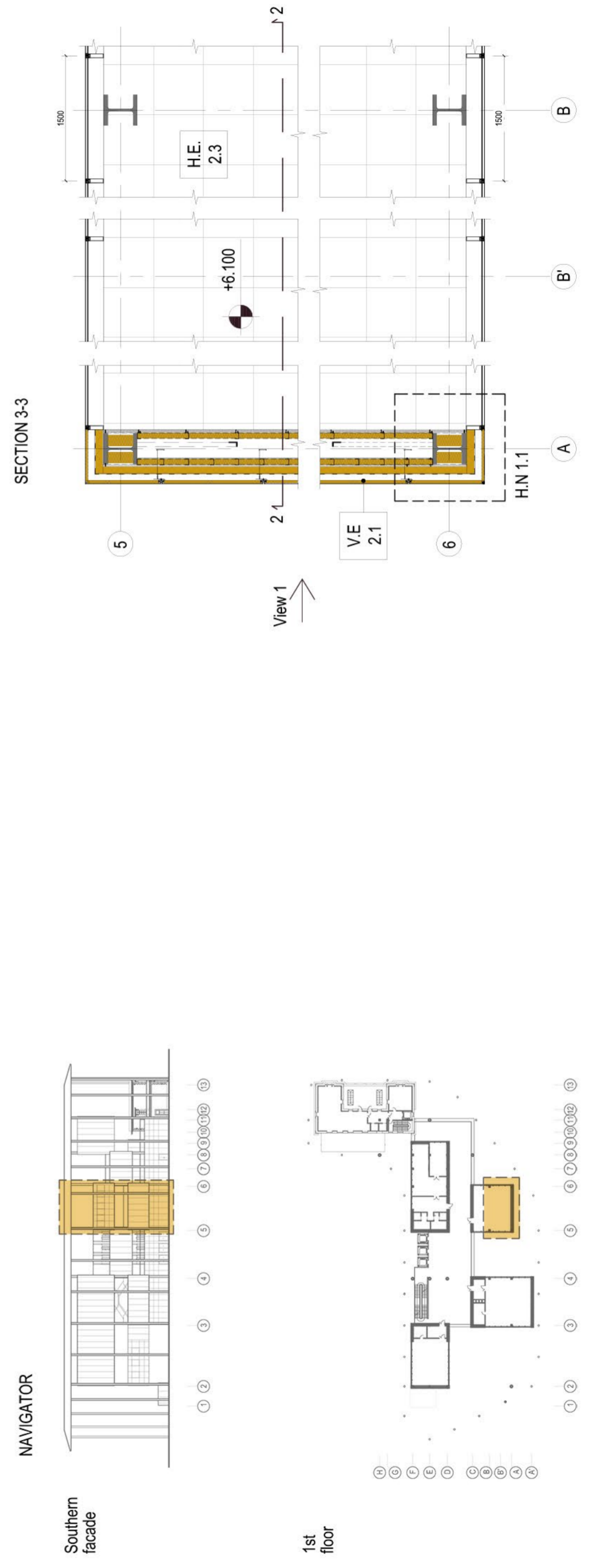
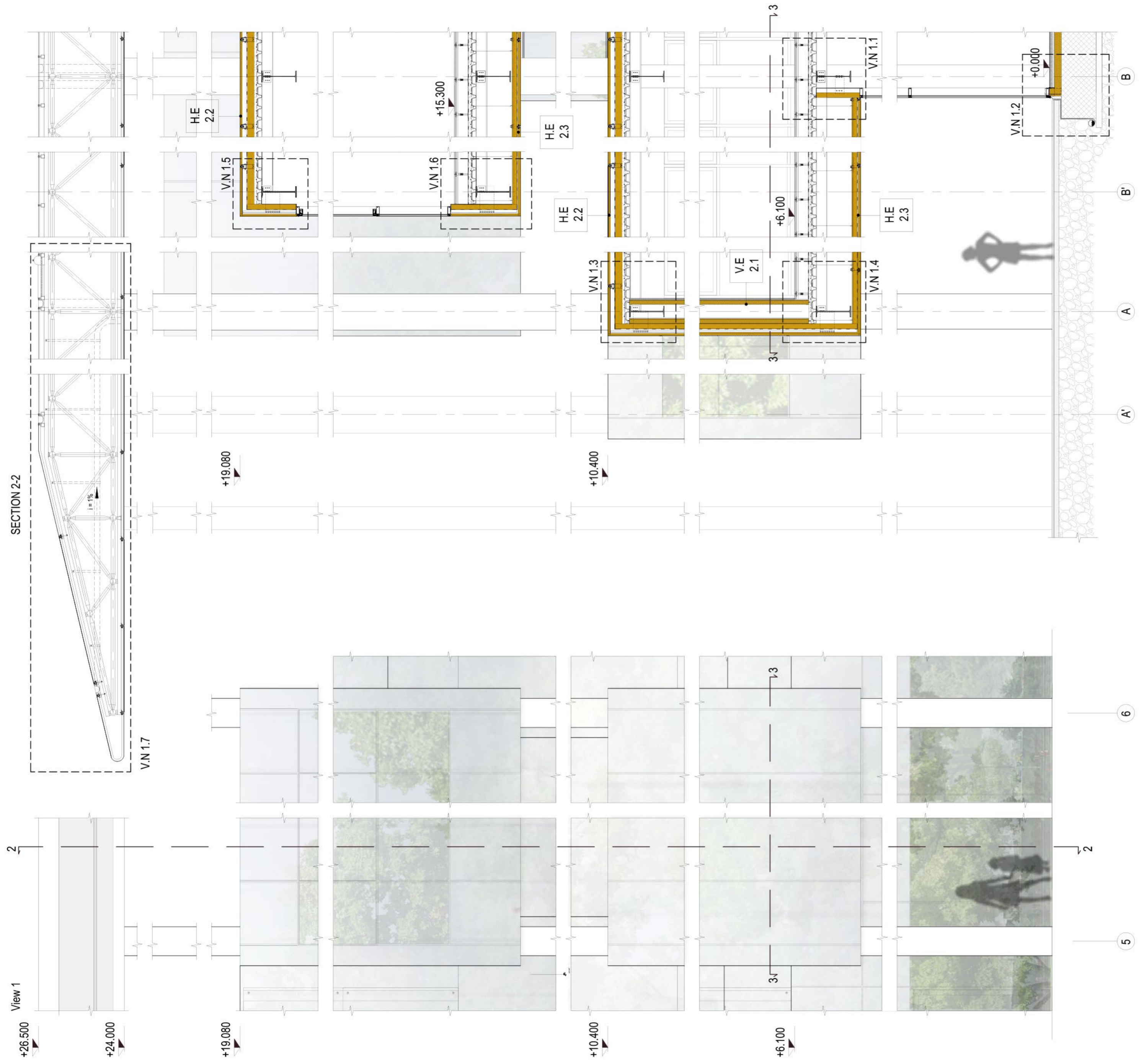

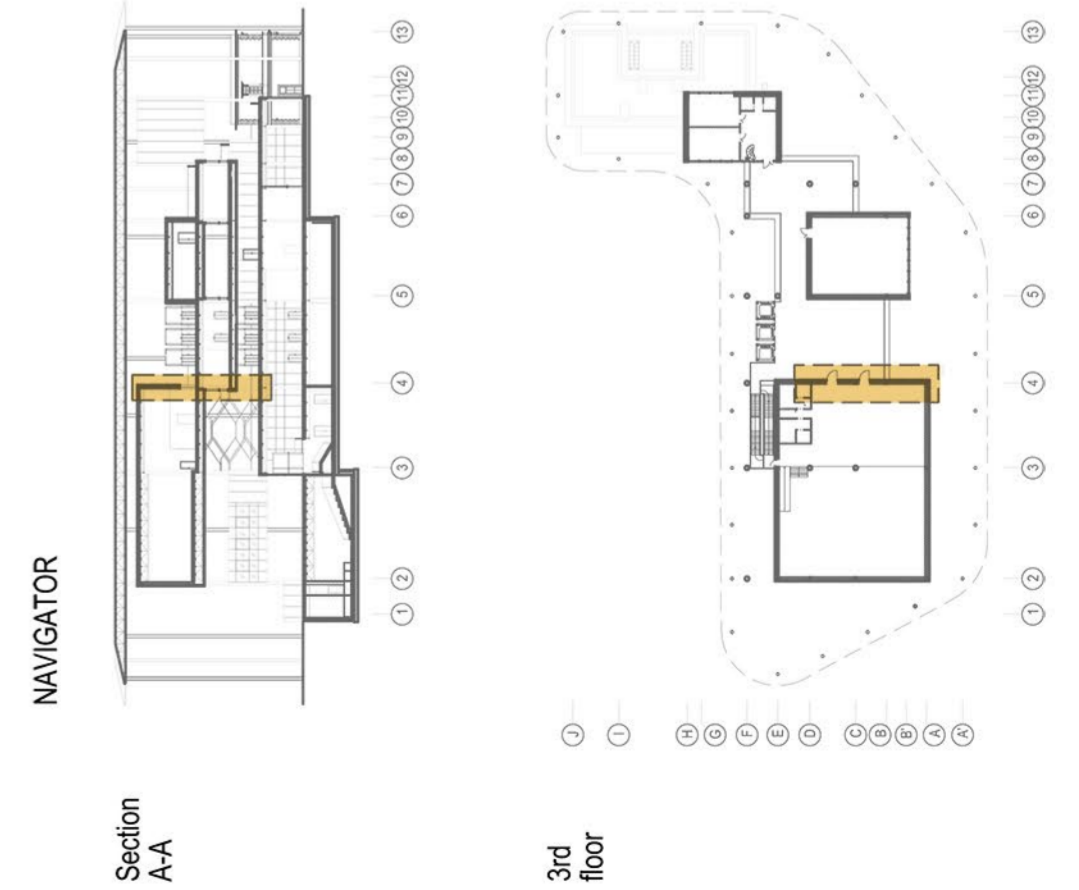
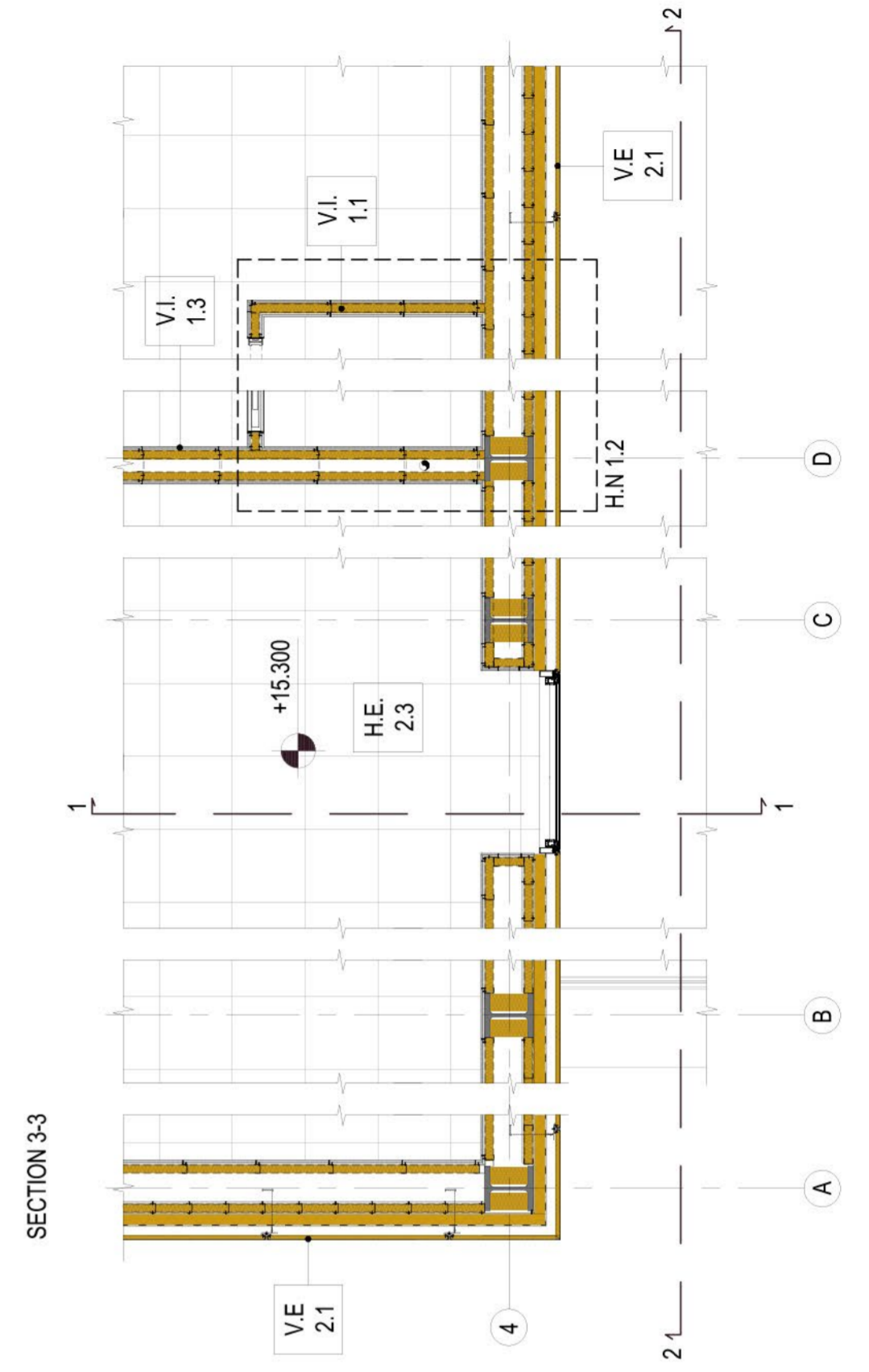
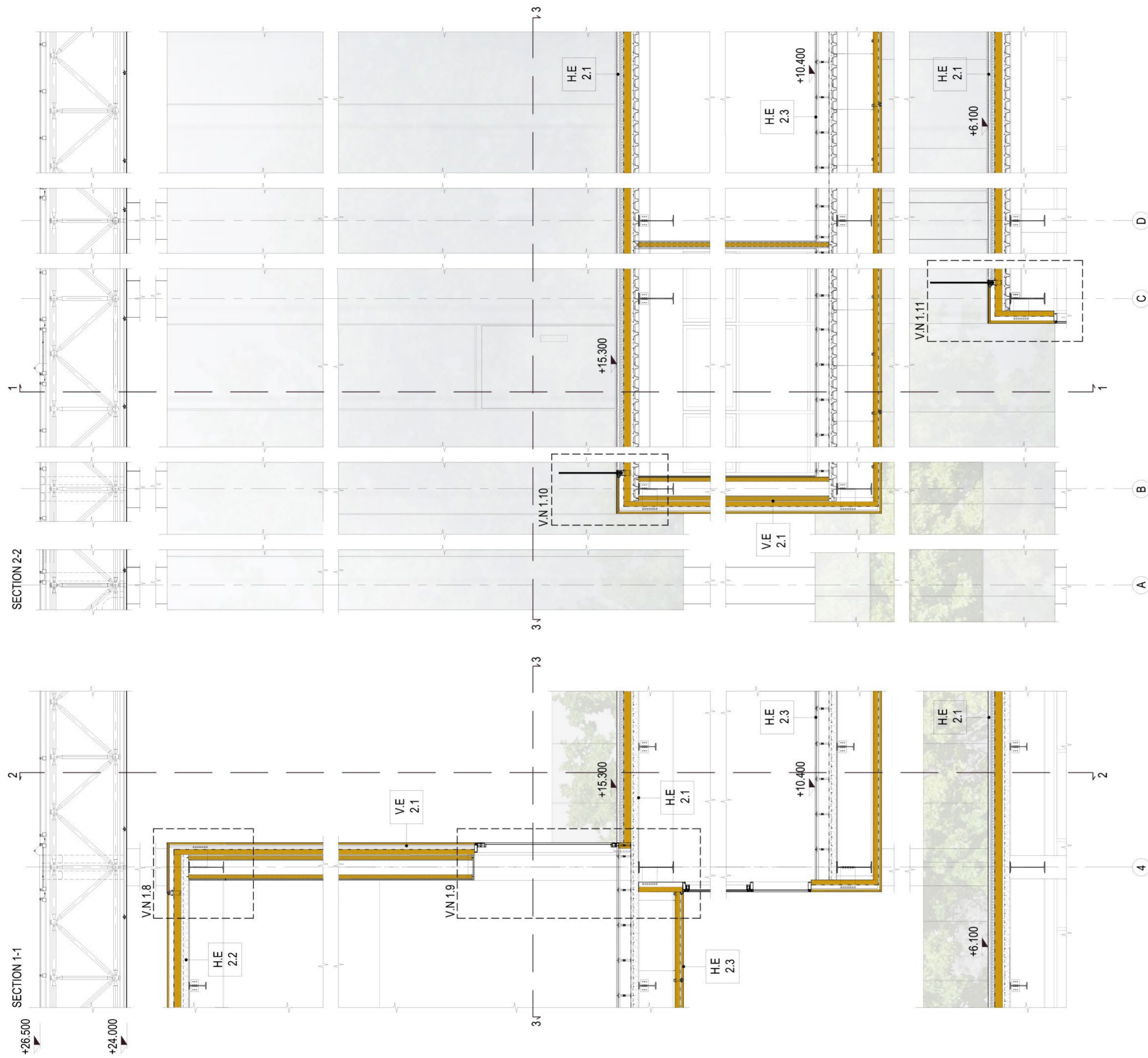

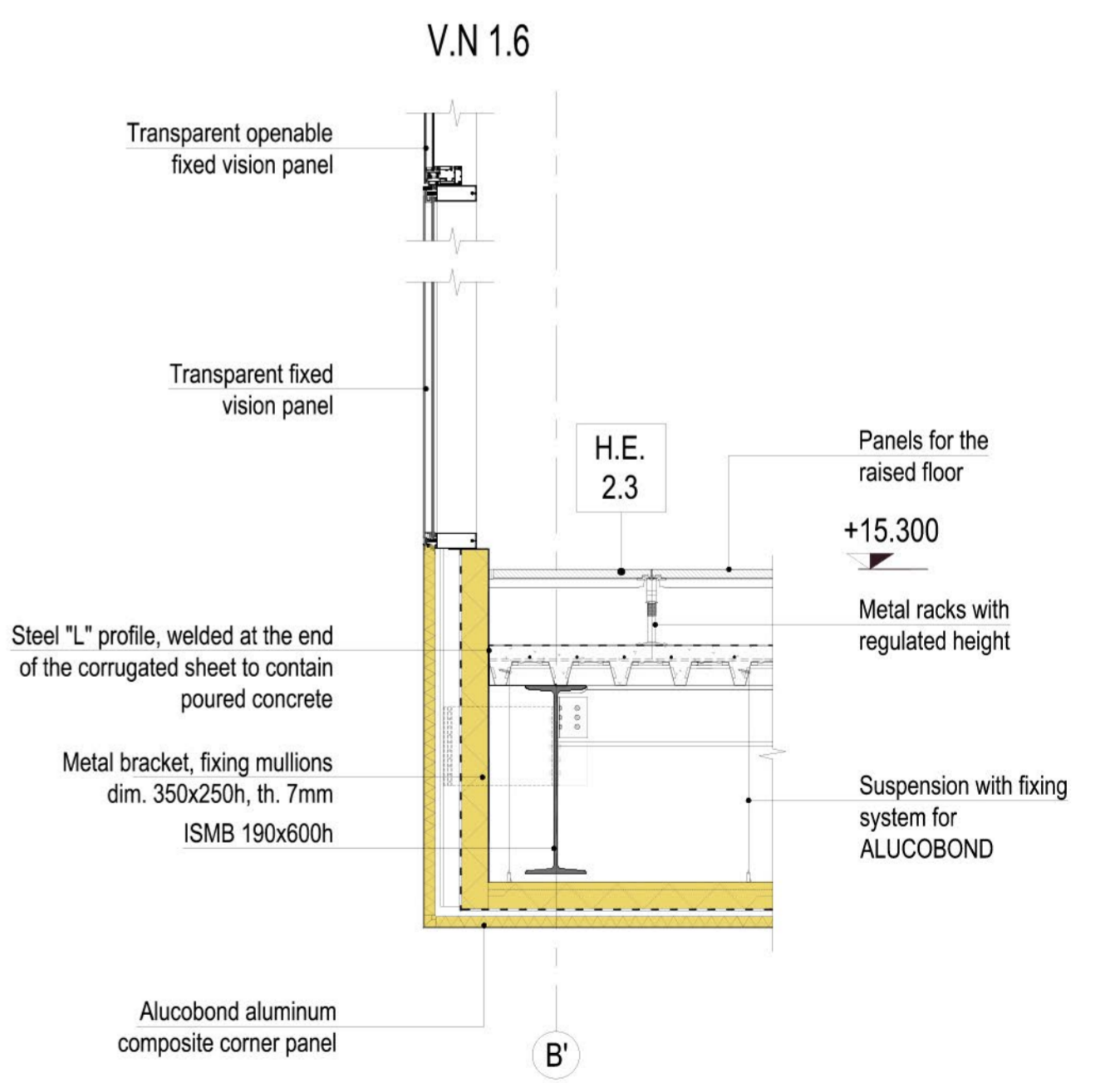
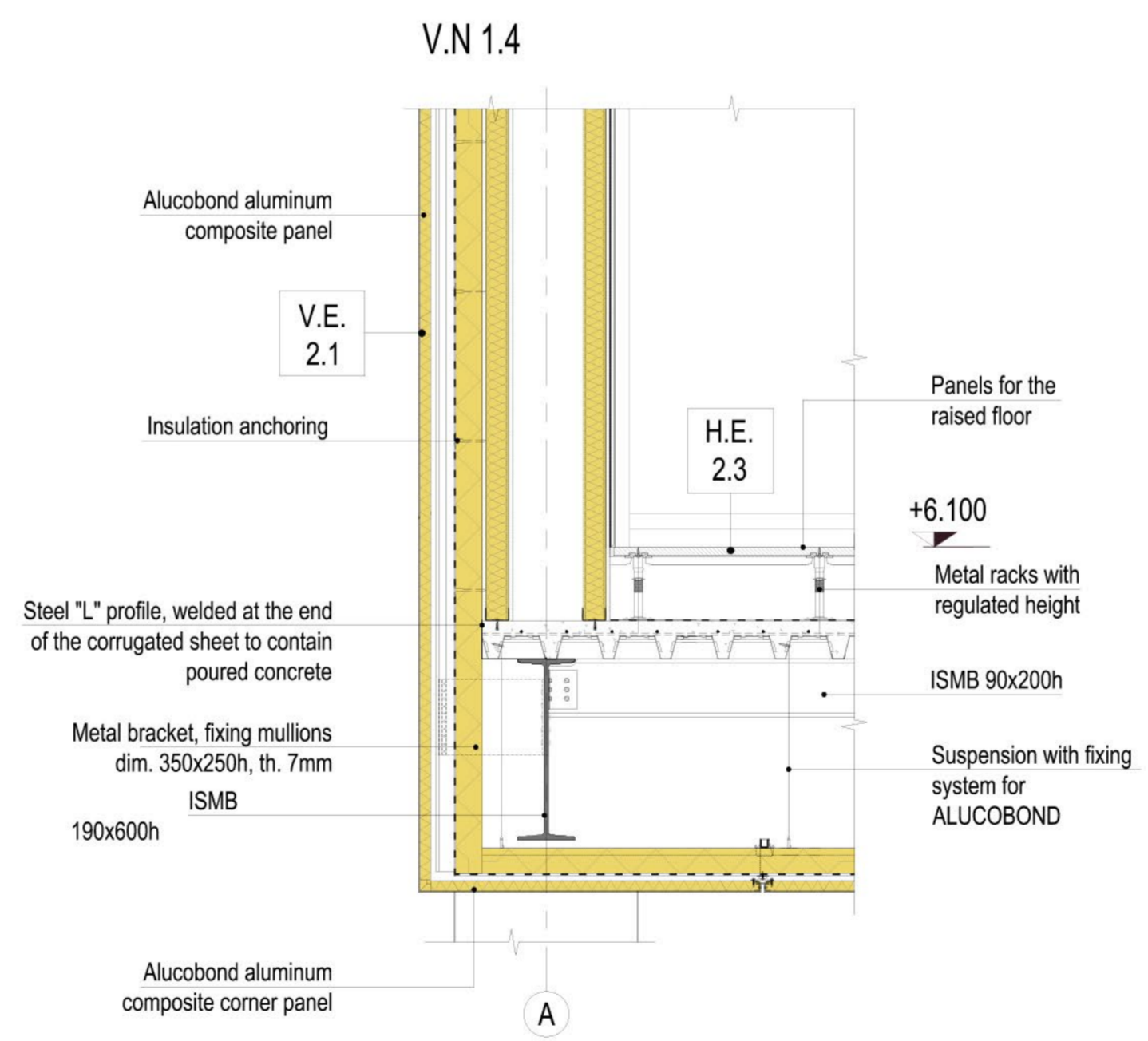
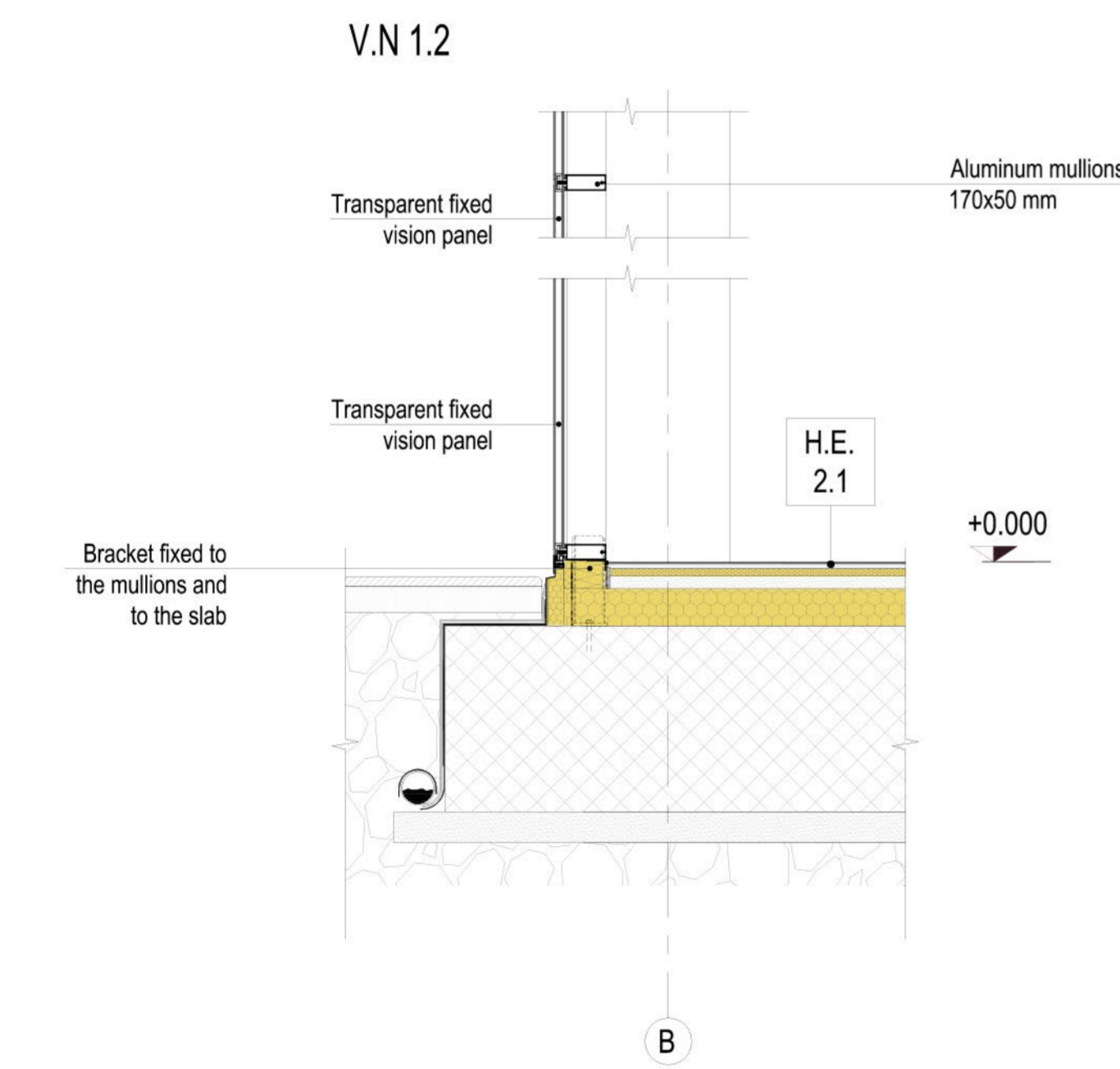
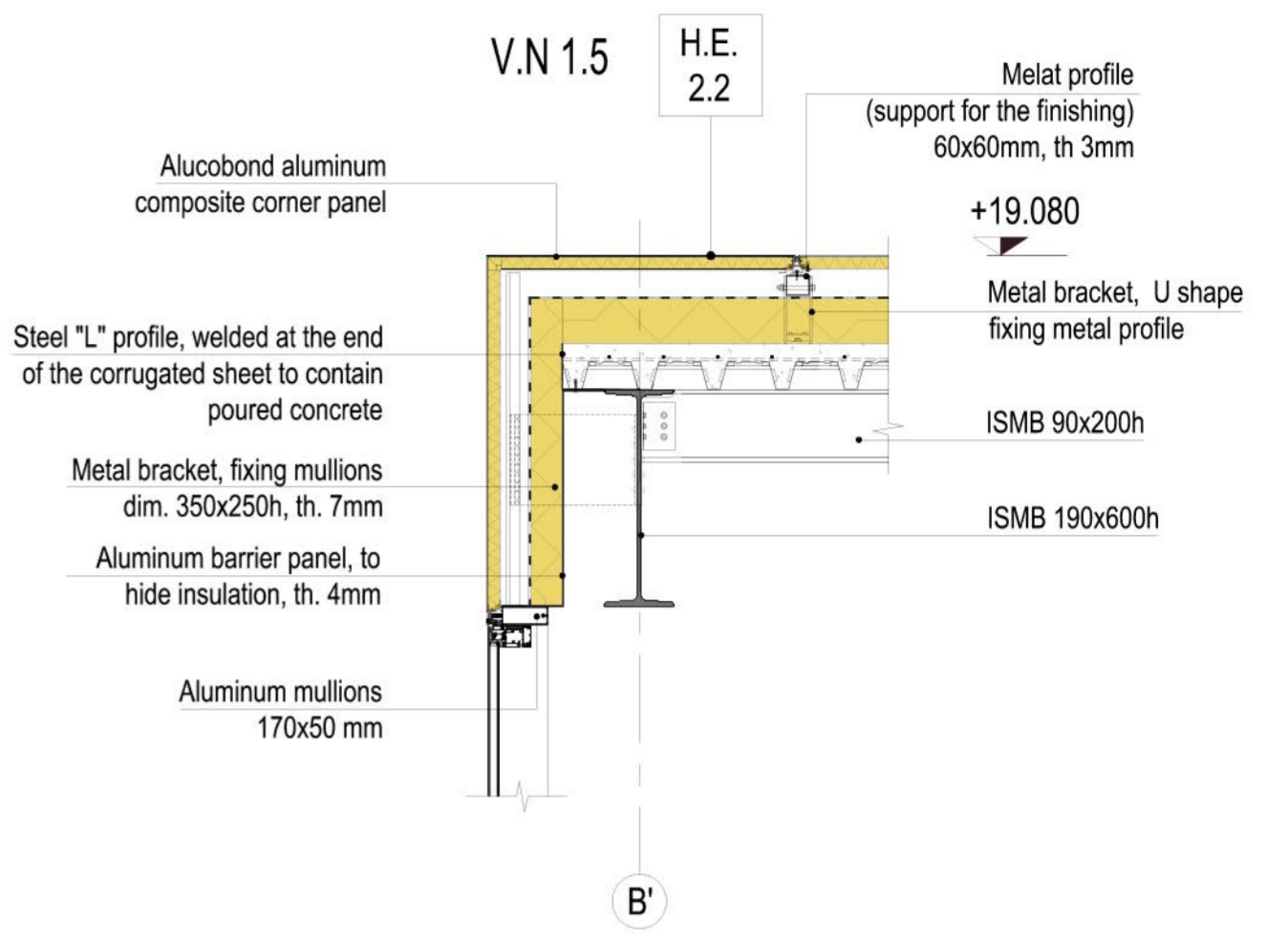
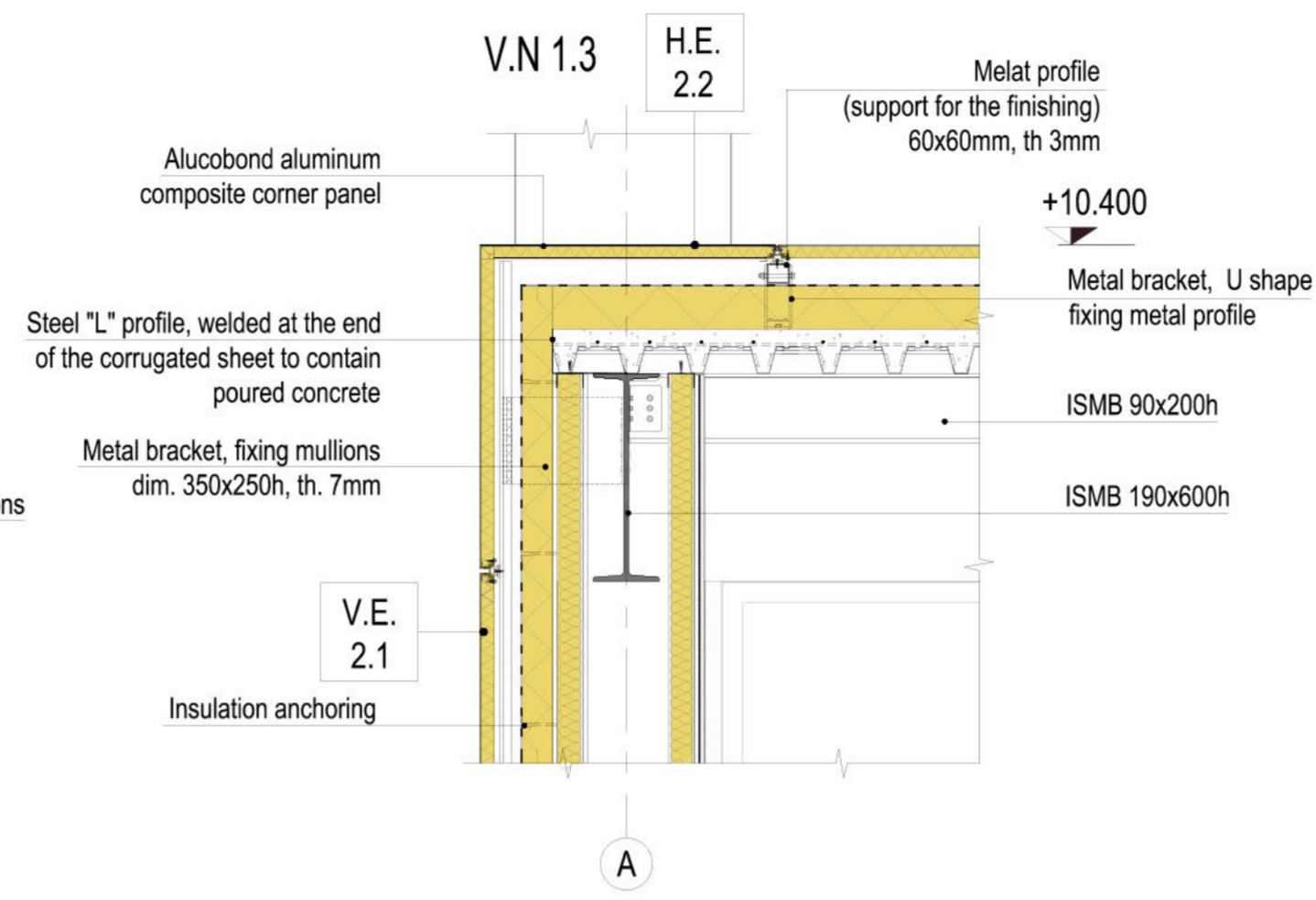
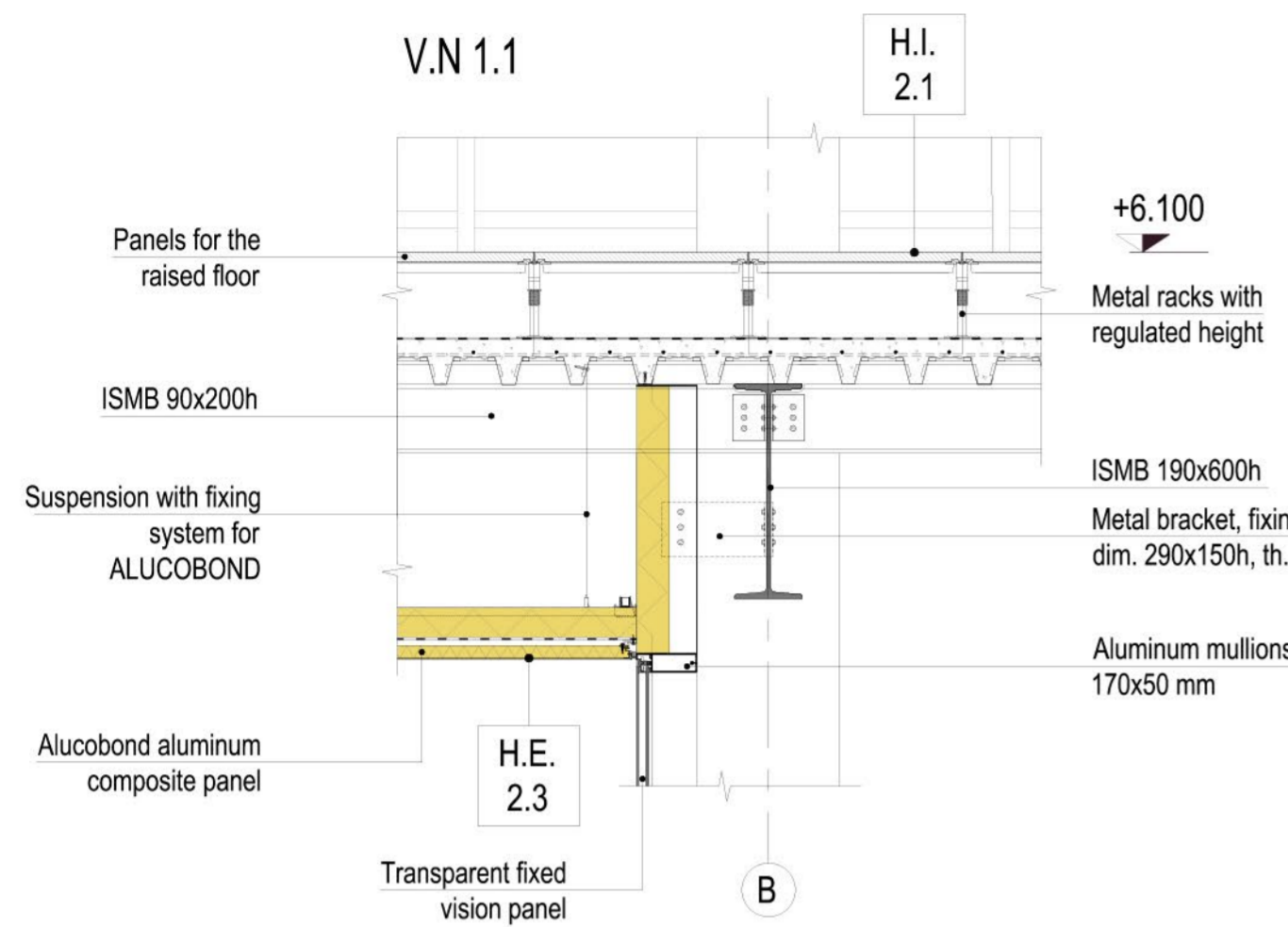

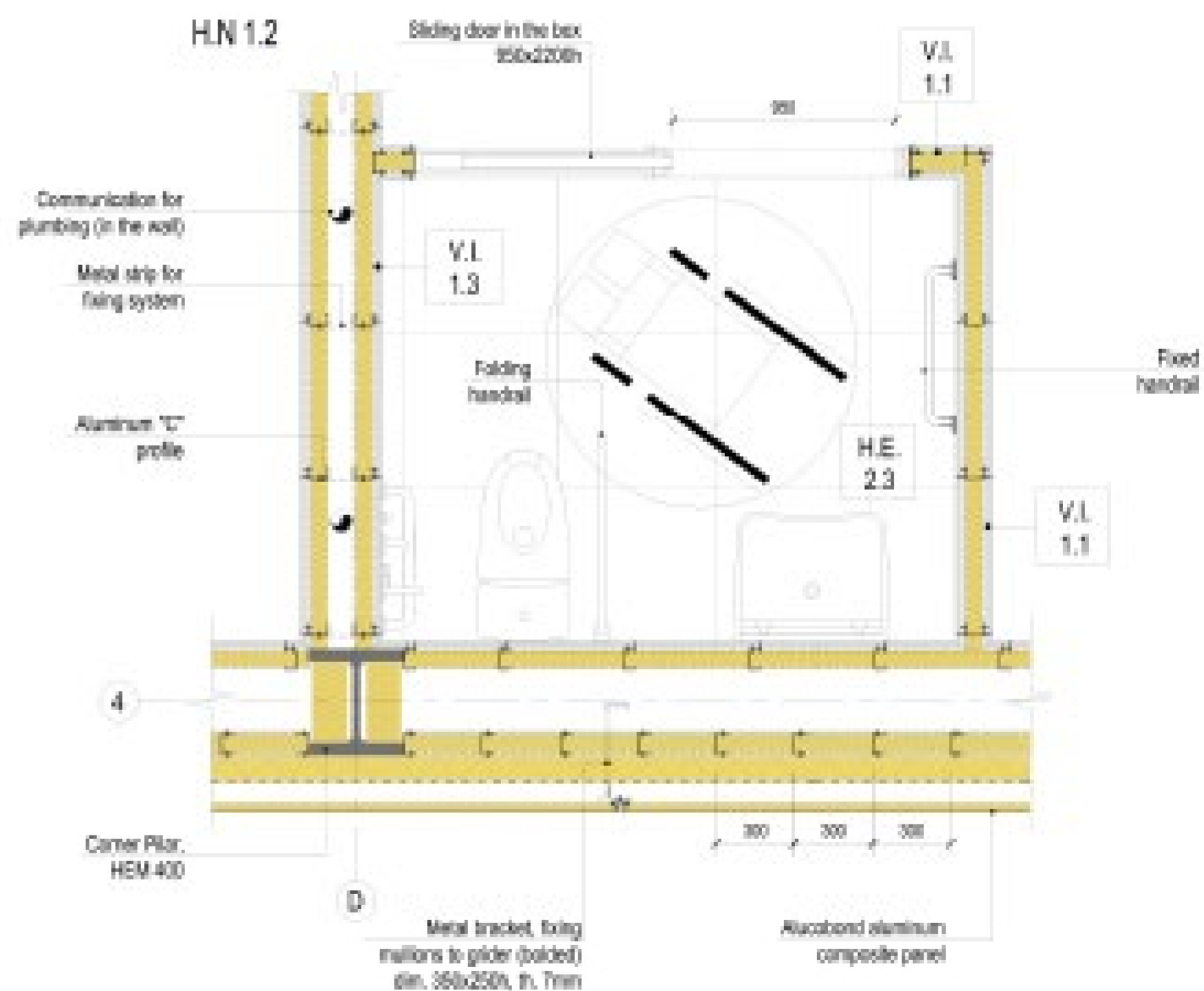
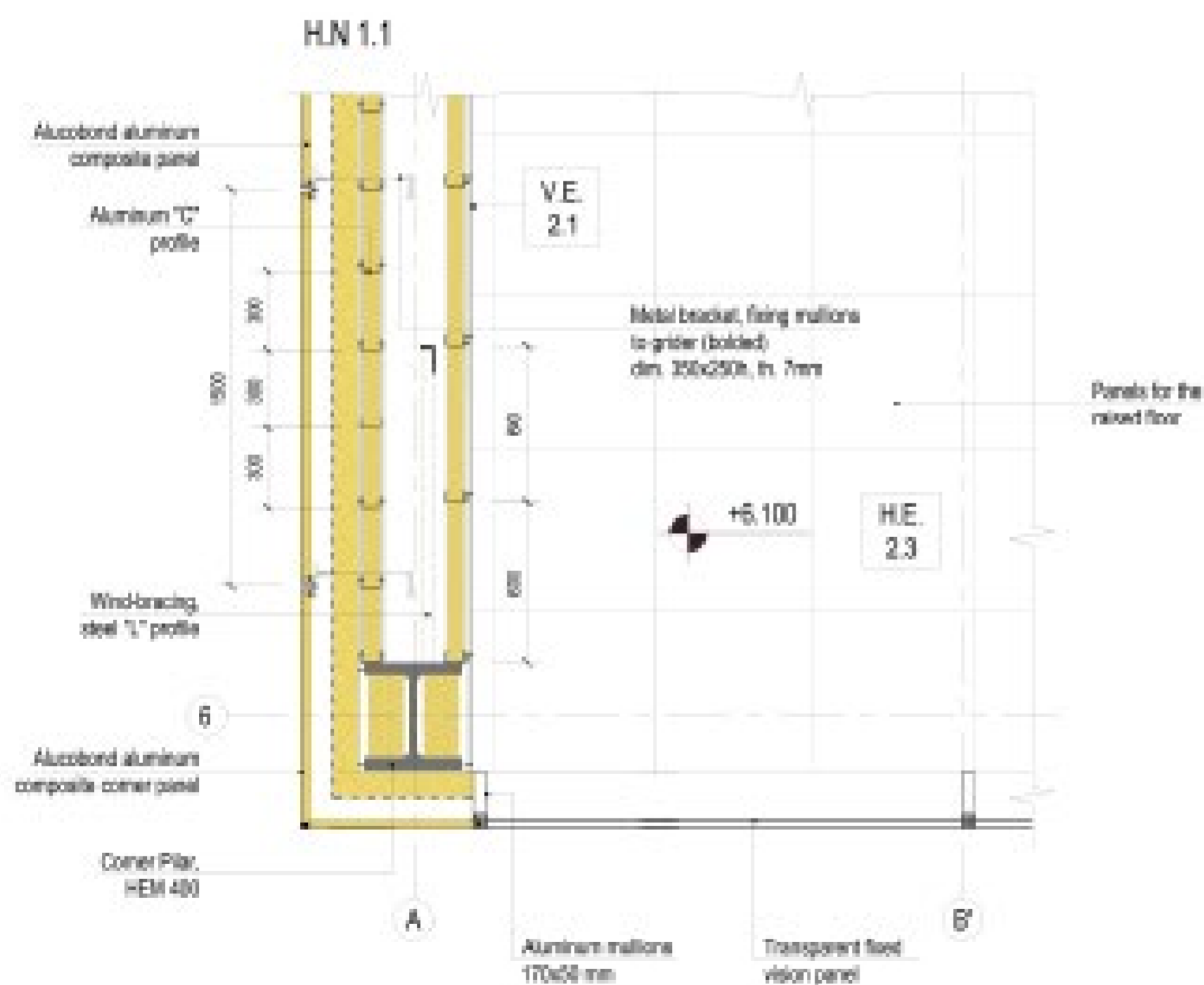
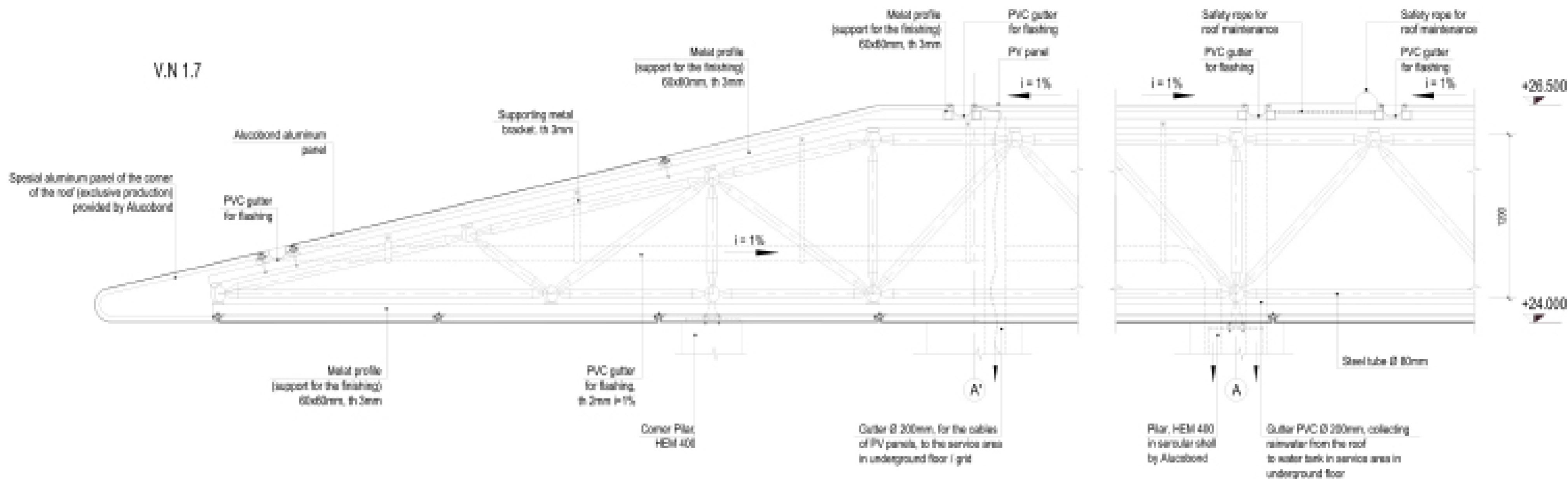

V.N 1.8

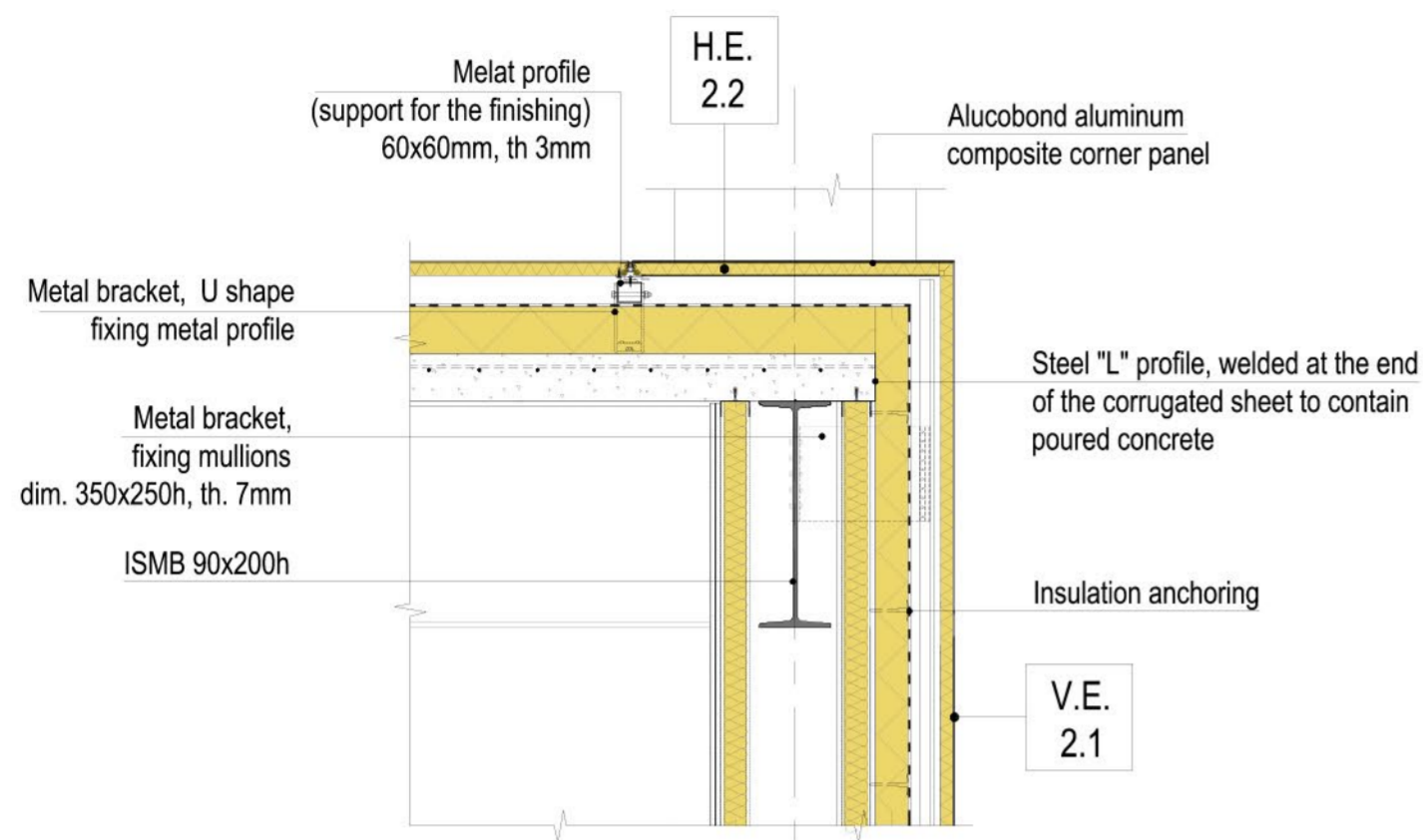

V.N 1.10

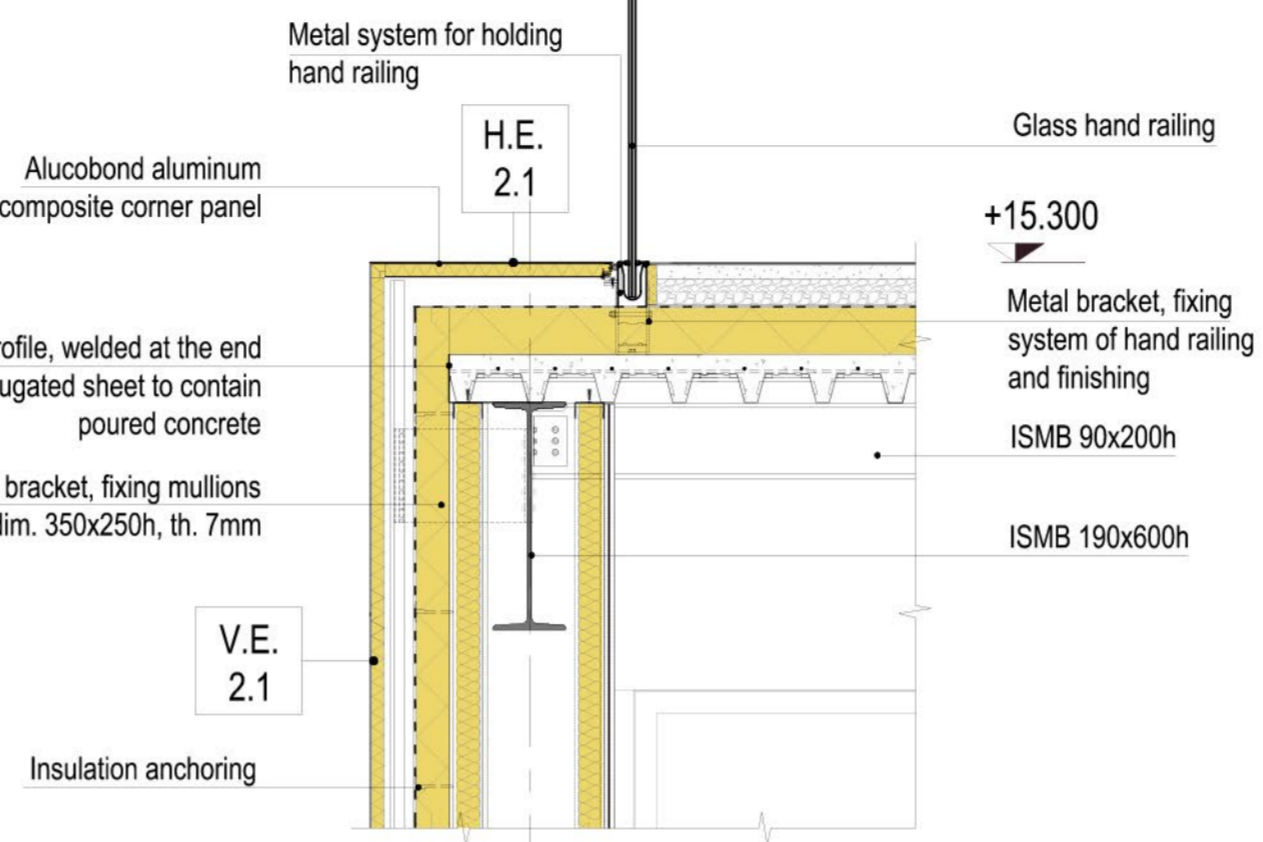

V.N 1.11

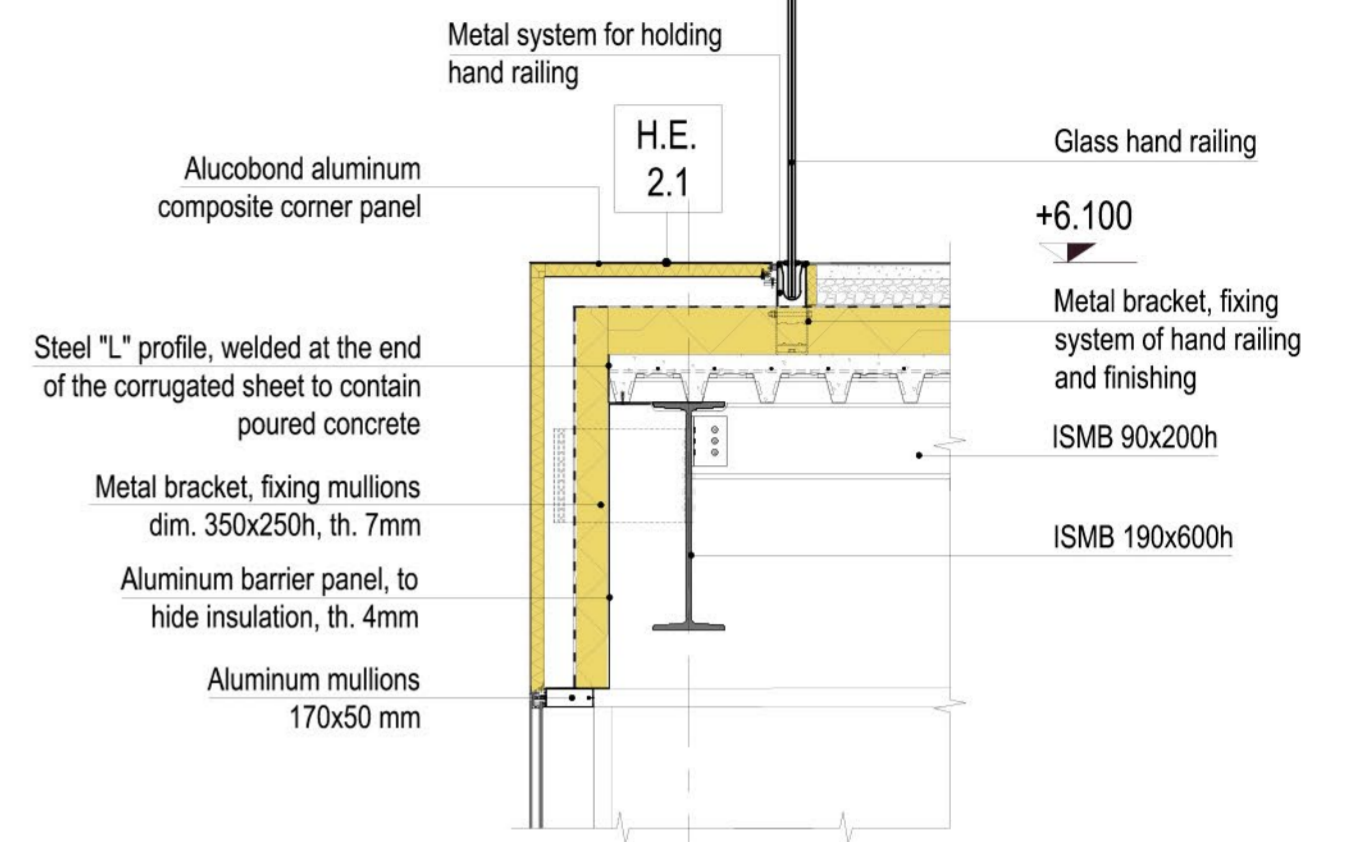

V.N 1.9

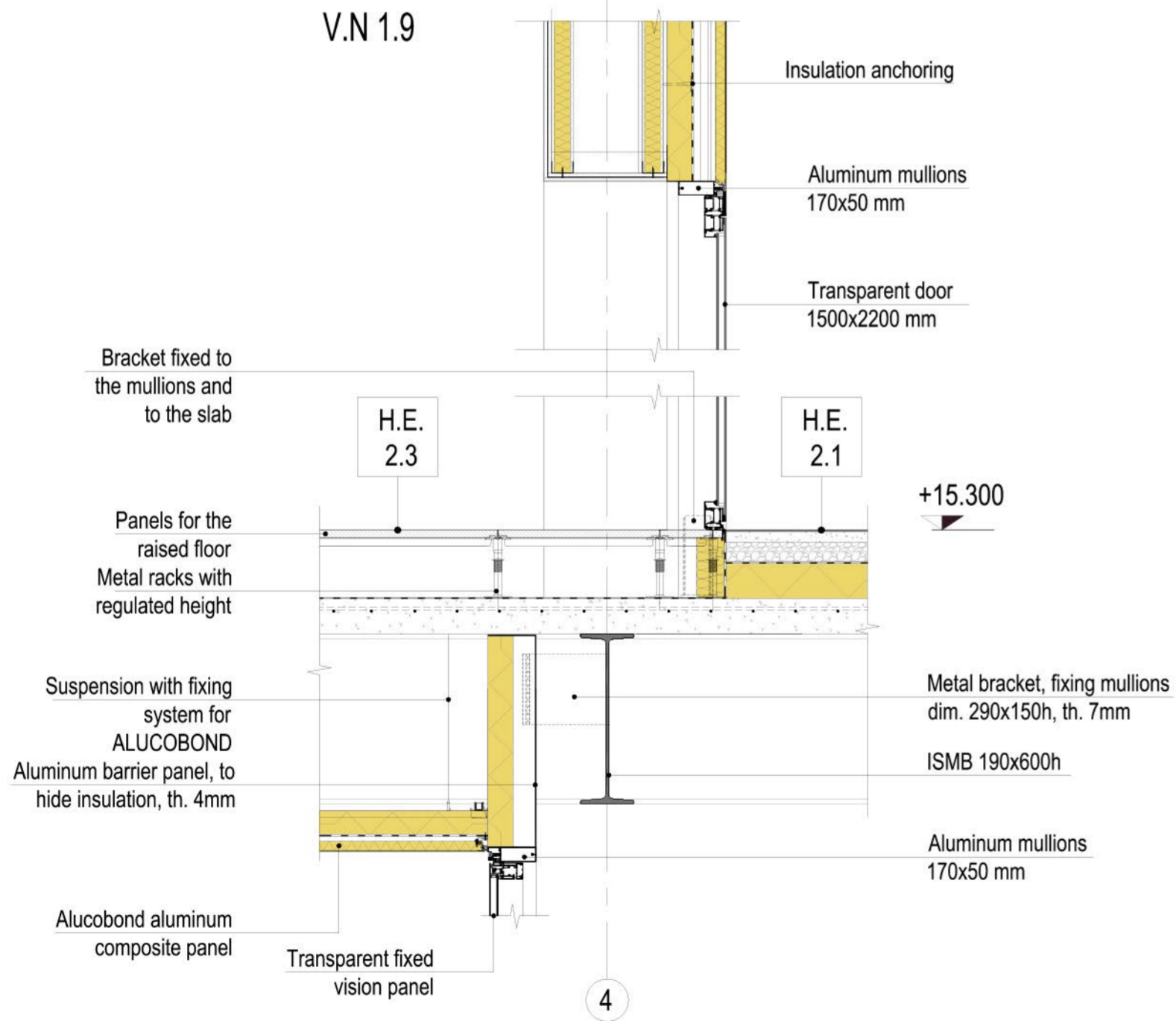

V.N 1.12

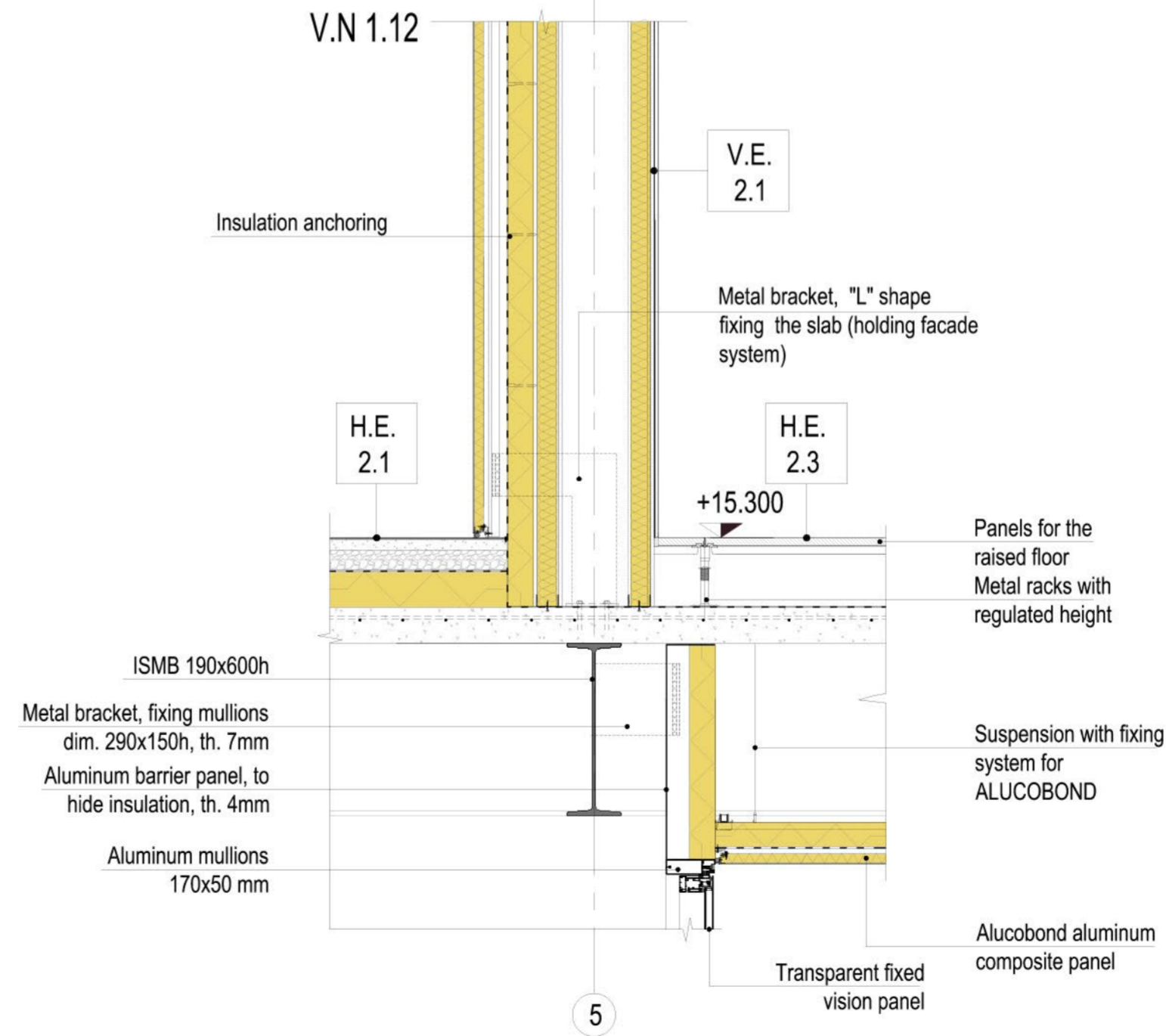

H.N 1.3

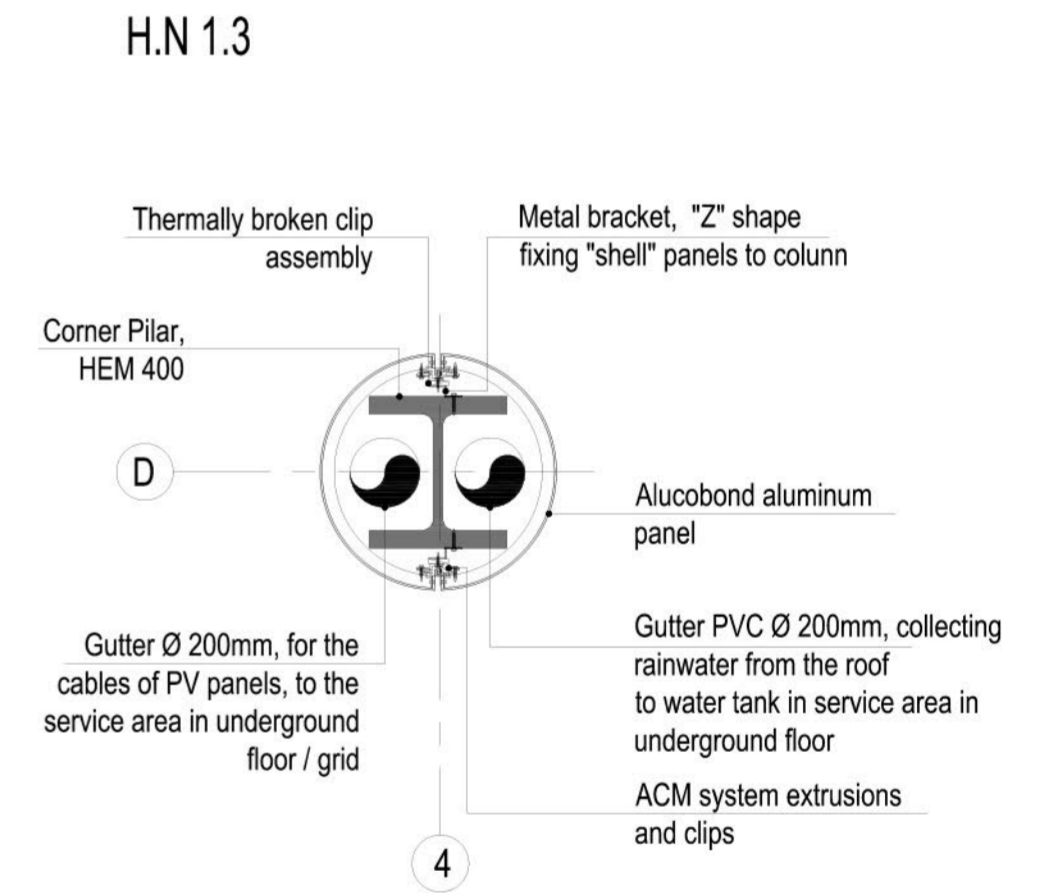

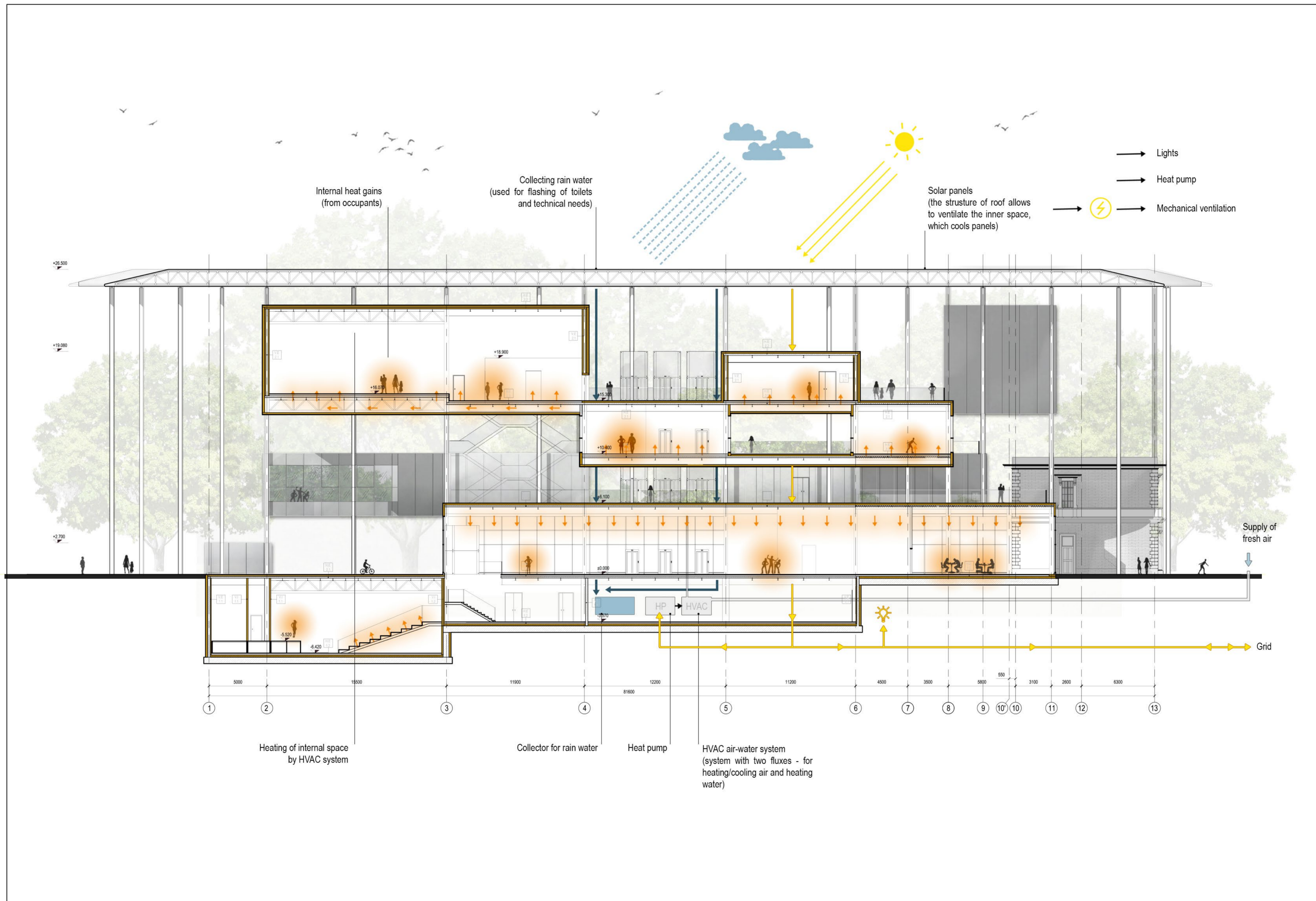

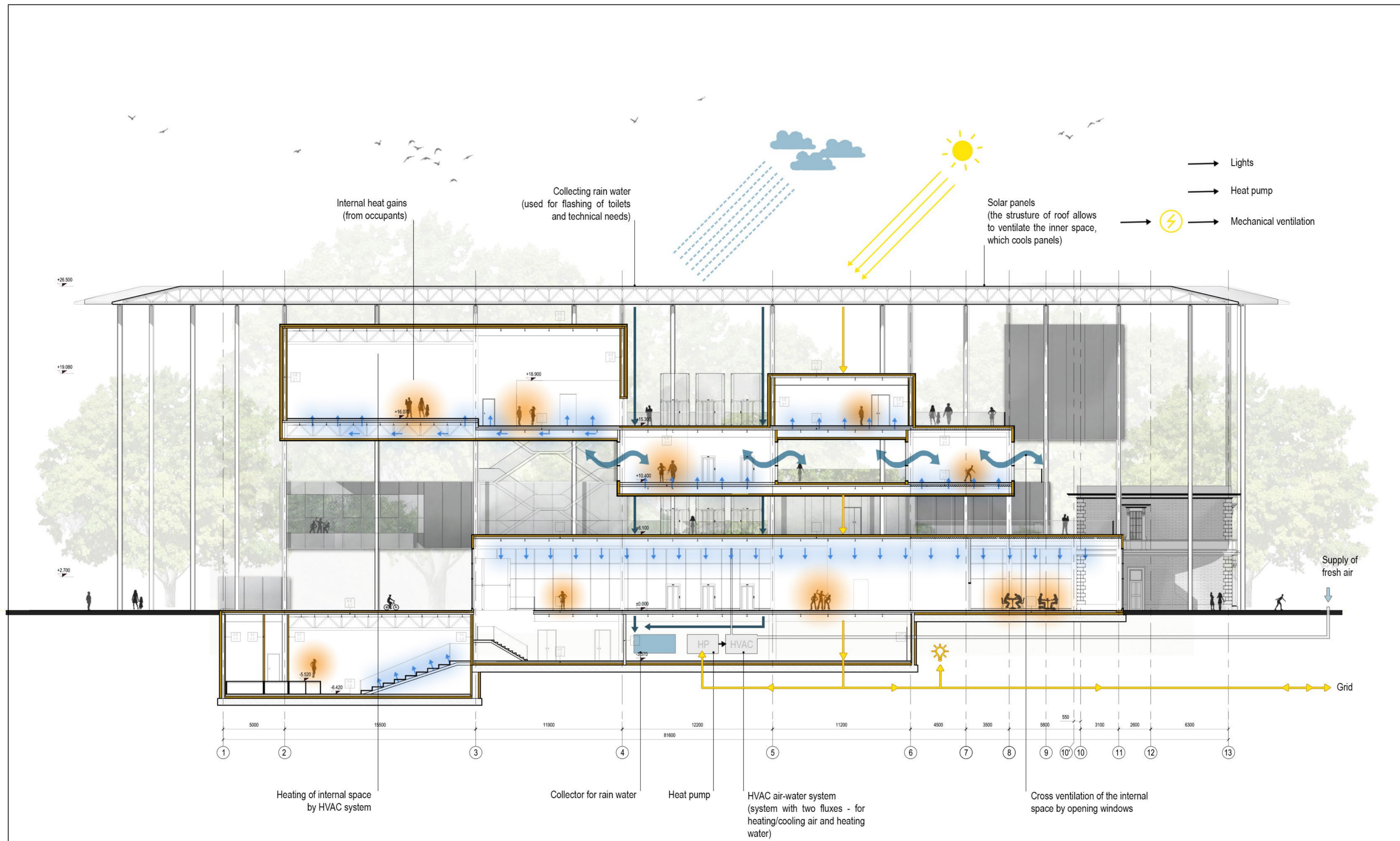

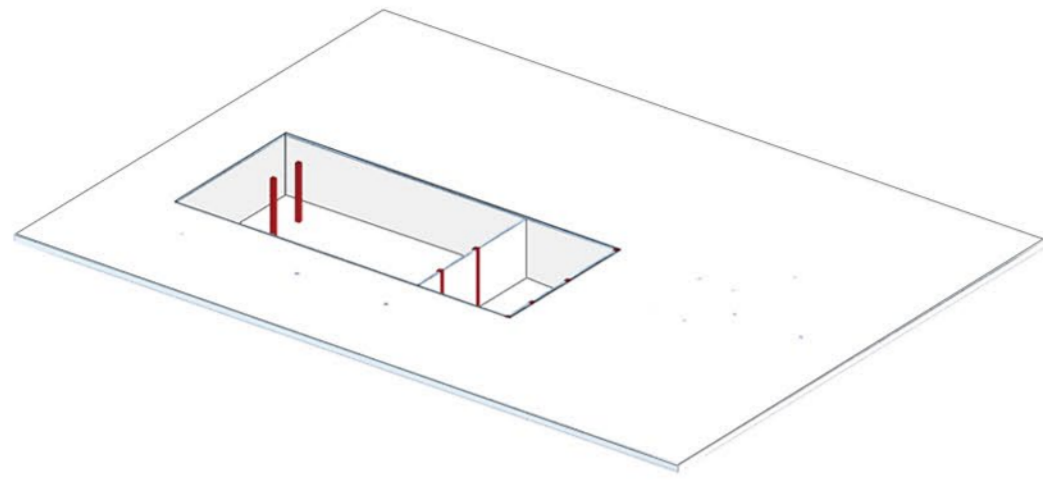

1. Foundation, concrete walls and columns of Underground floor



2. Steel columns of the Ground level

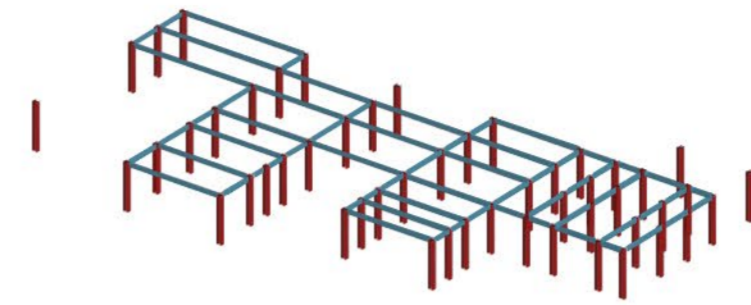

3. Primary beams of the Ground level

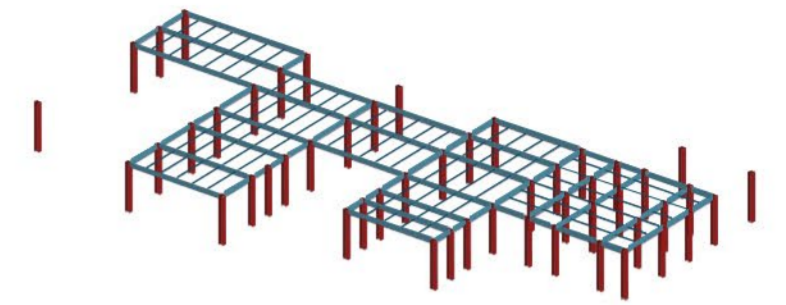

4. Secondary beams of the Ground level

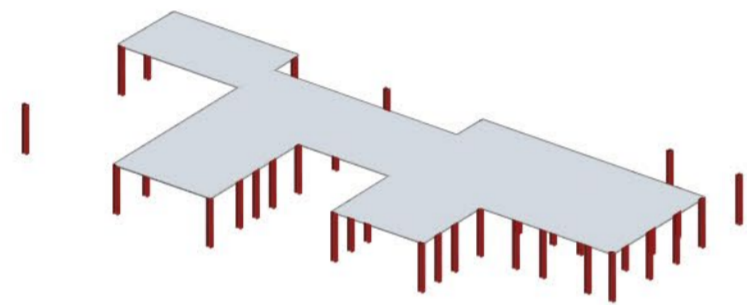

5. Construction of corrugated metal sheet with composite casting in concrete on the Ground level

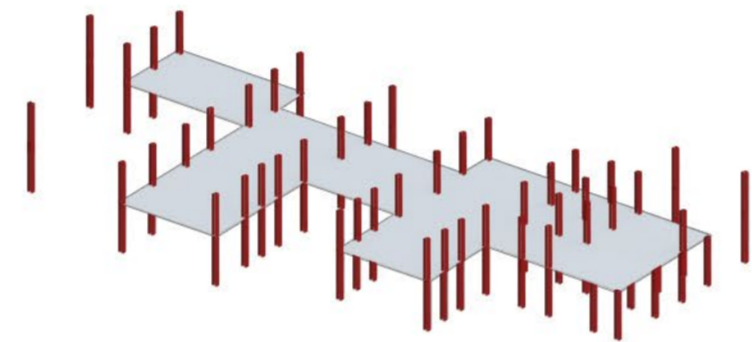

6. Steel columns of the First level

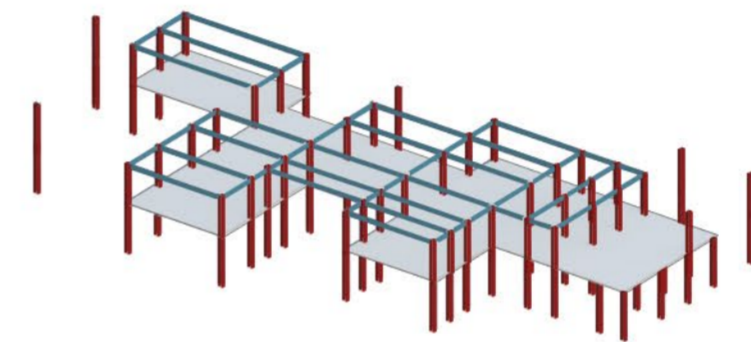

7. Primary beams of the First level

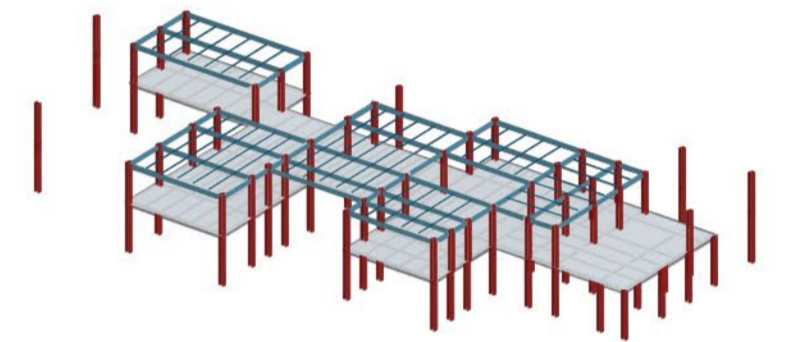

8. Secondary beams of the First level

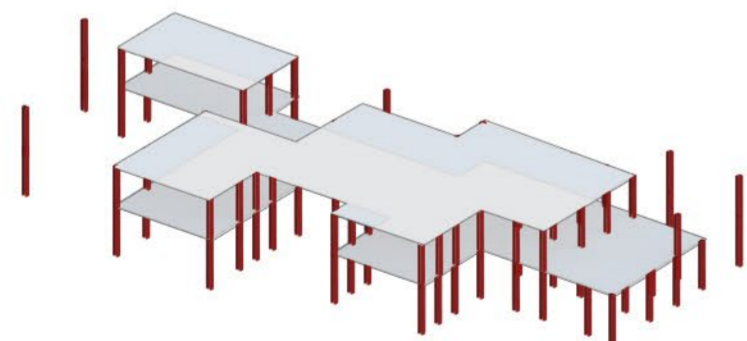

9. Construction of corrugated metal sheet with composite casting in concrete on the First level

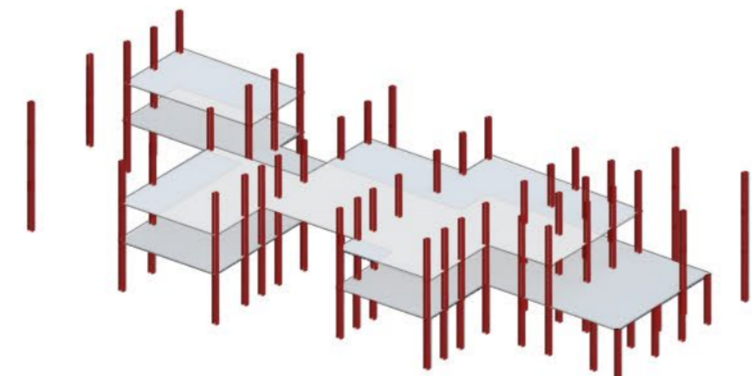

10. Steel columns of the Second level

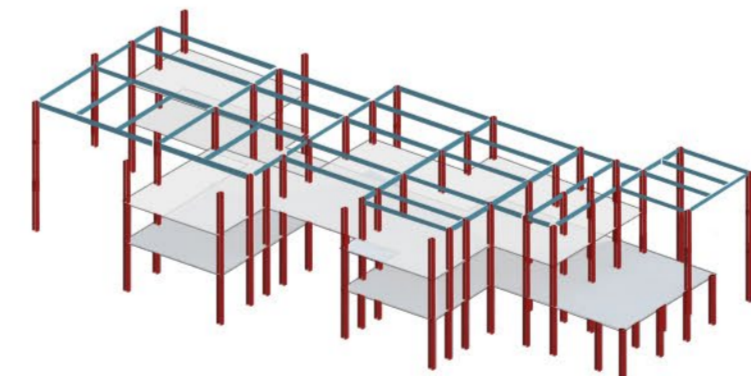

11. Primary beams of the Second level

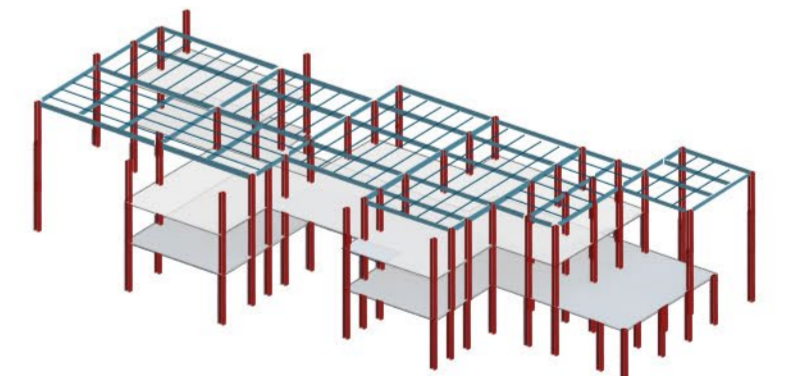

12. Secondary beams of the Second level

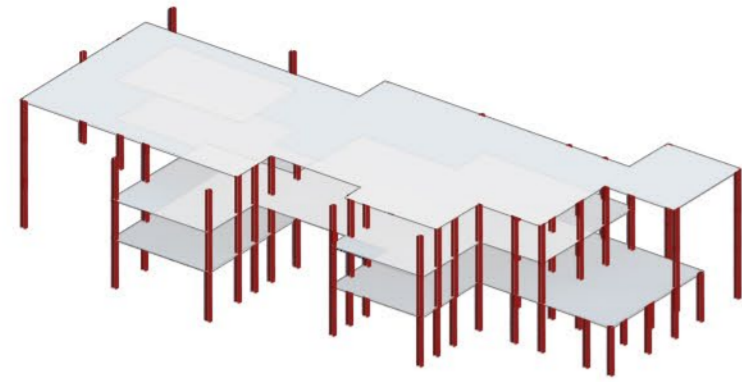

13. Construction of corrugated metal sheet with composite casting in concrete on the Second level

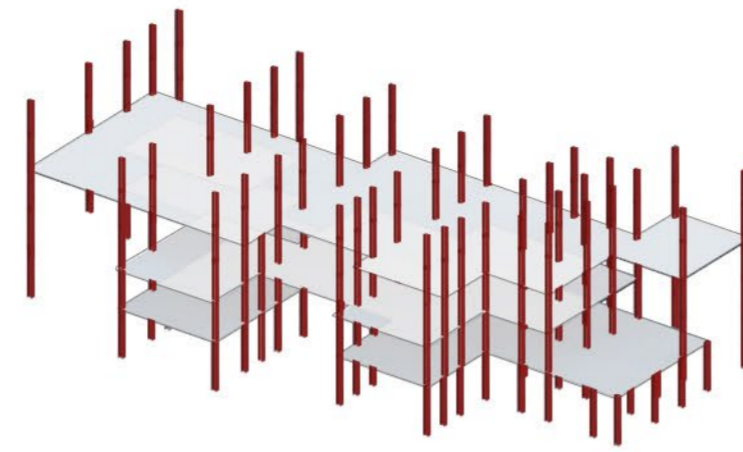

14. Steel columns of the Third level

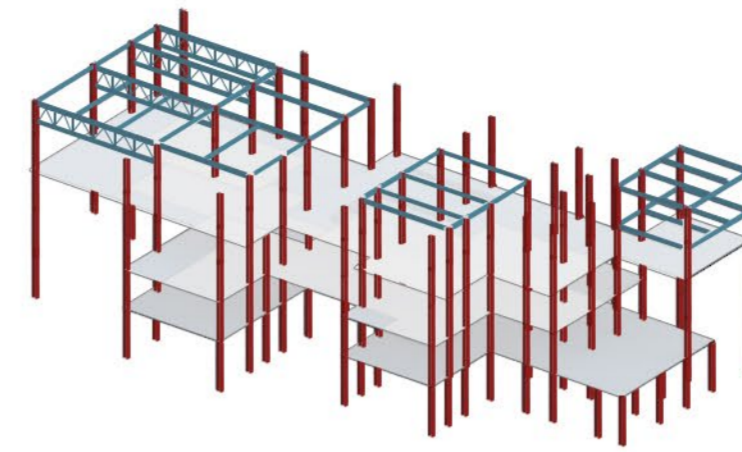

15. Primary beams of the Third level

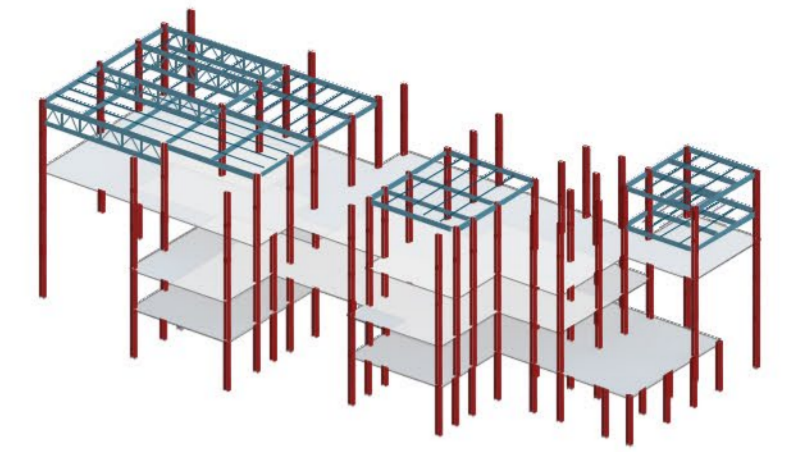

16. Secondary beams of the Third level

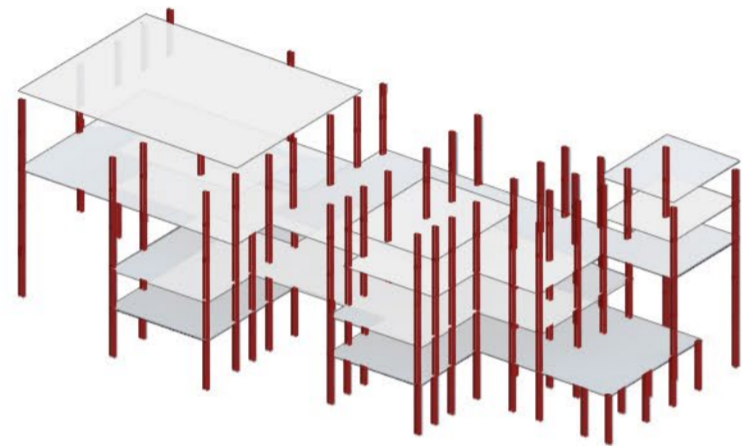

17. Construction of corrugated metal sheet with composite casting in concrete on the Third level

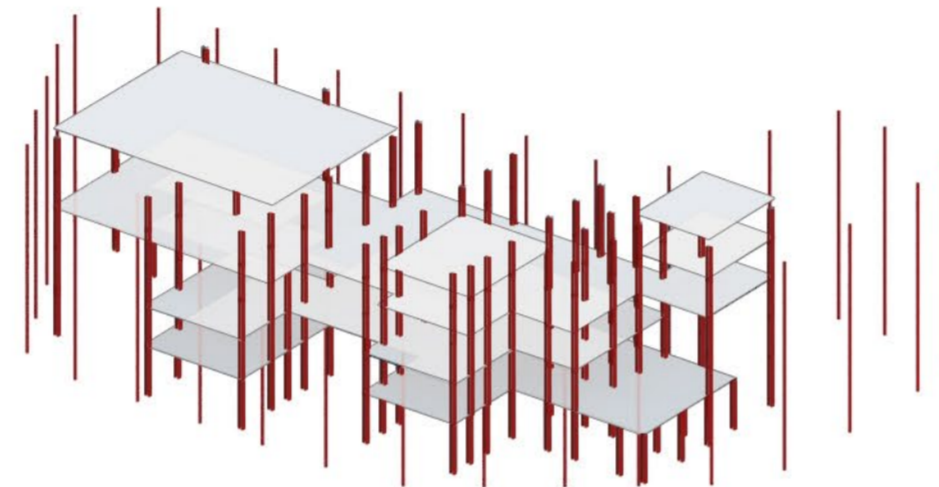

18. External columns, which support roof

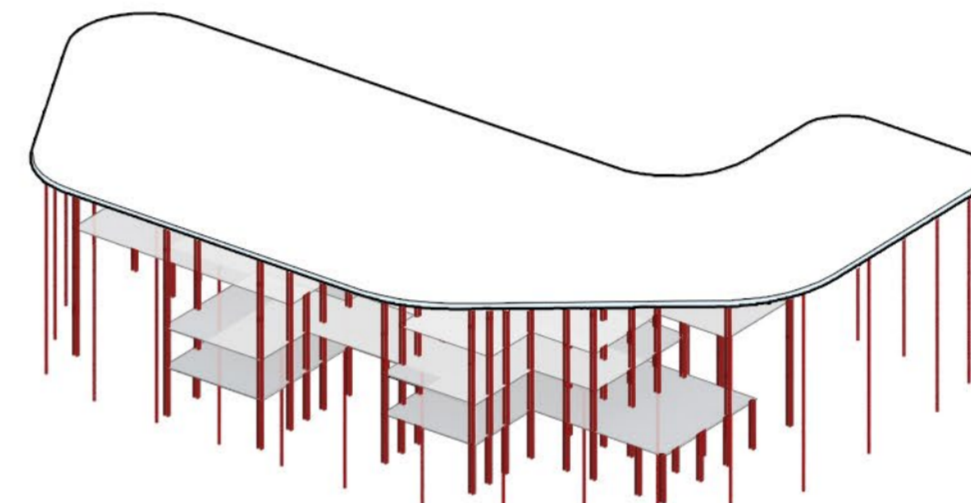

19. Construction of the roof

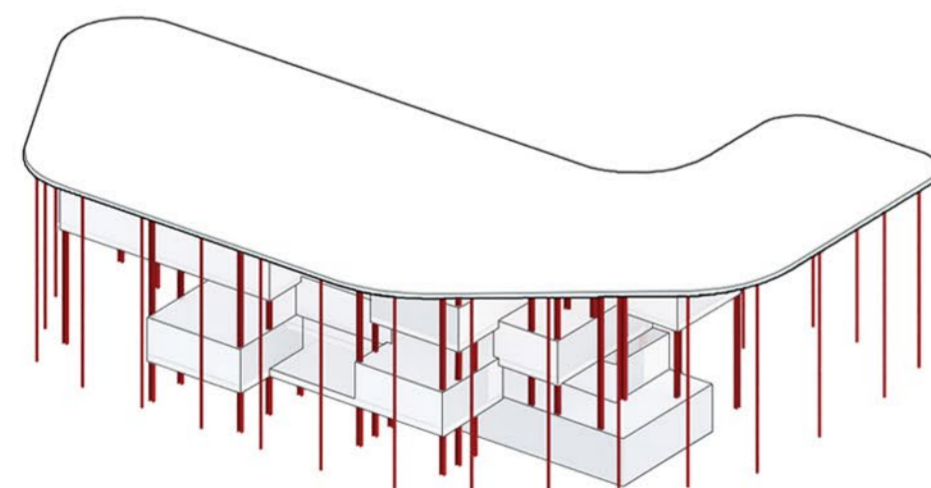

20. Construction of the external walls

Space truss

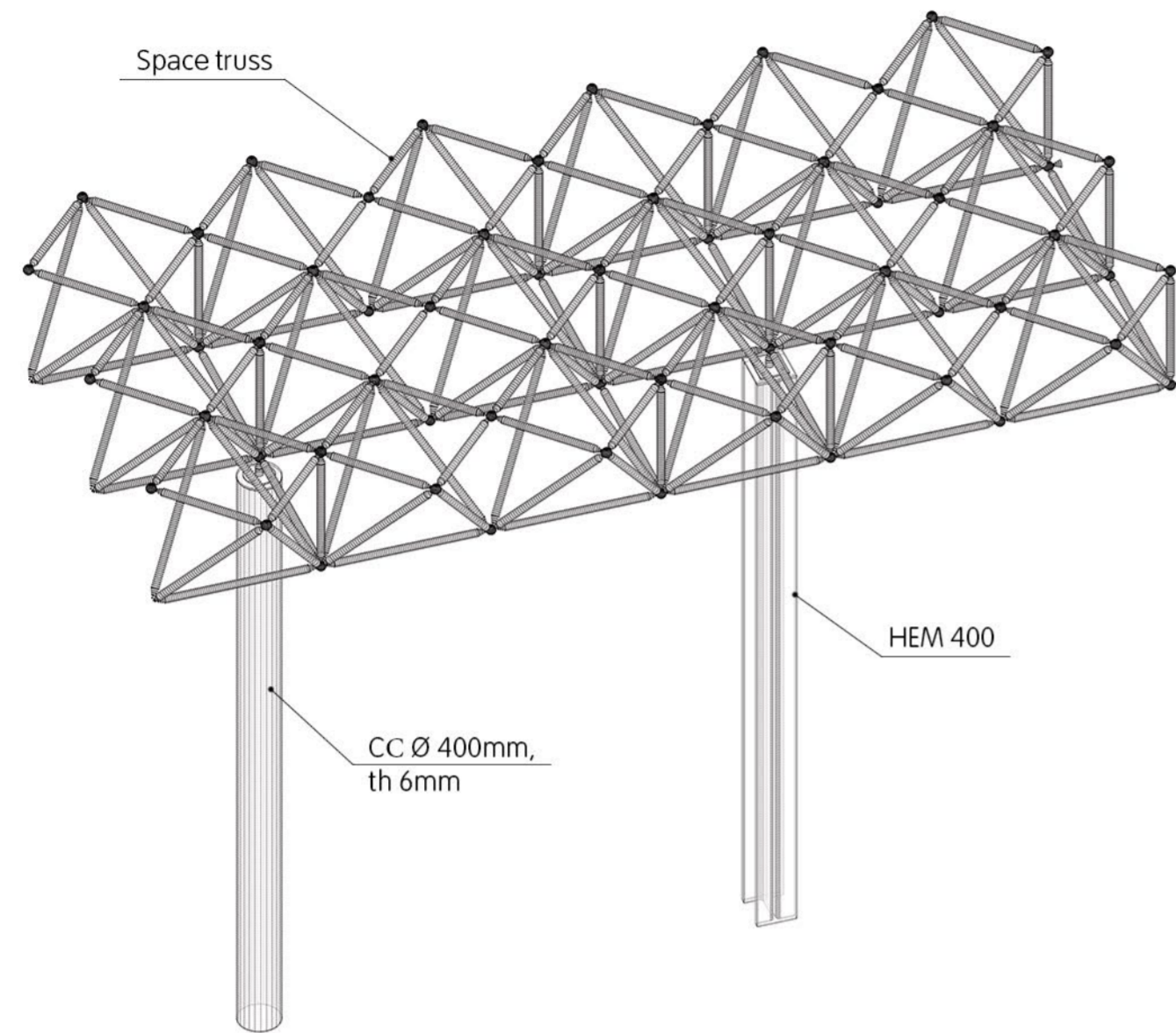

Connection of the roof and the column

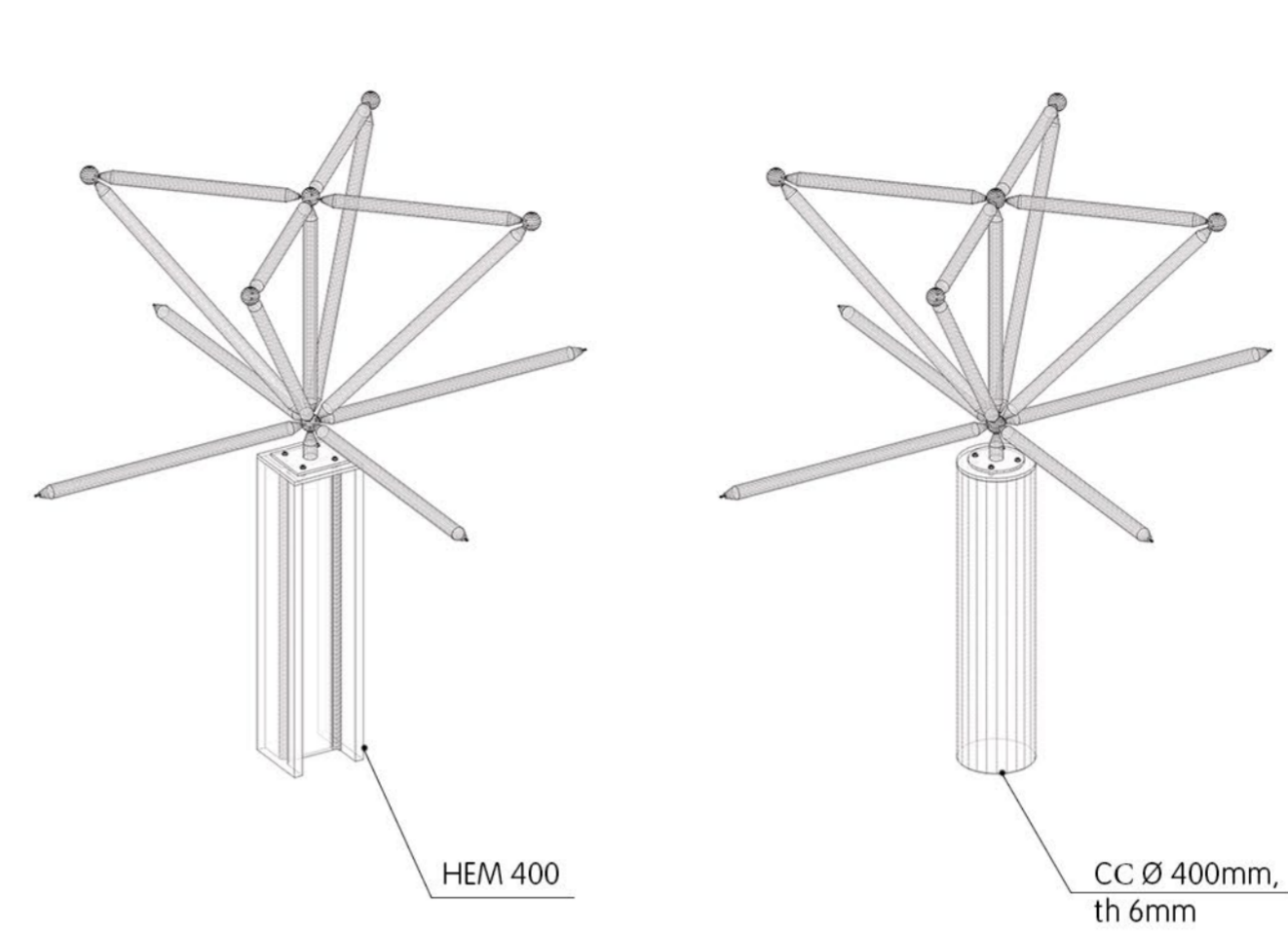

Foundation of the column

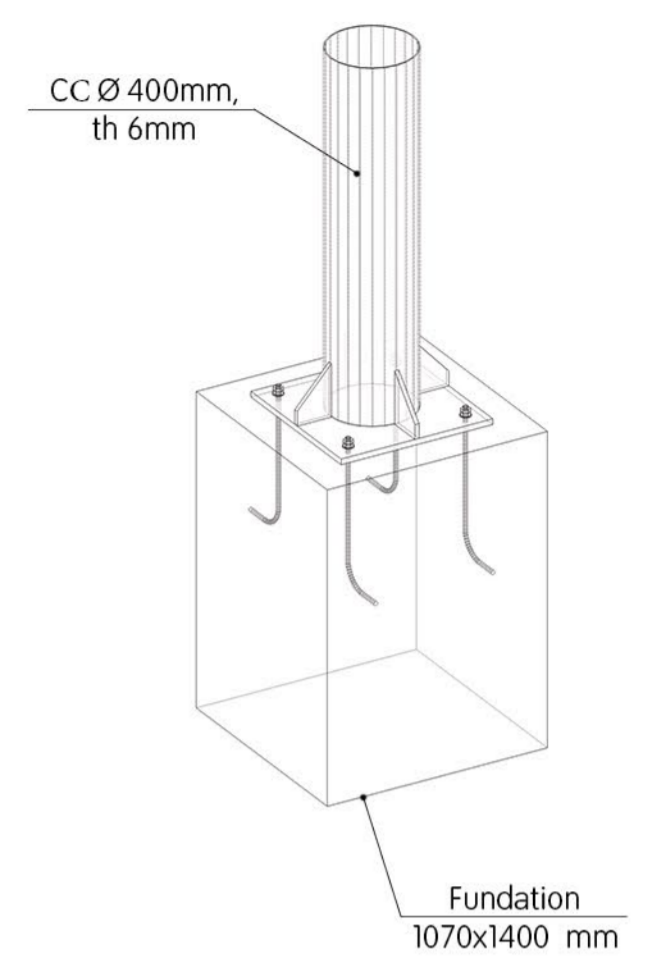

System with HEM column and truss

System with HEM column and beam

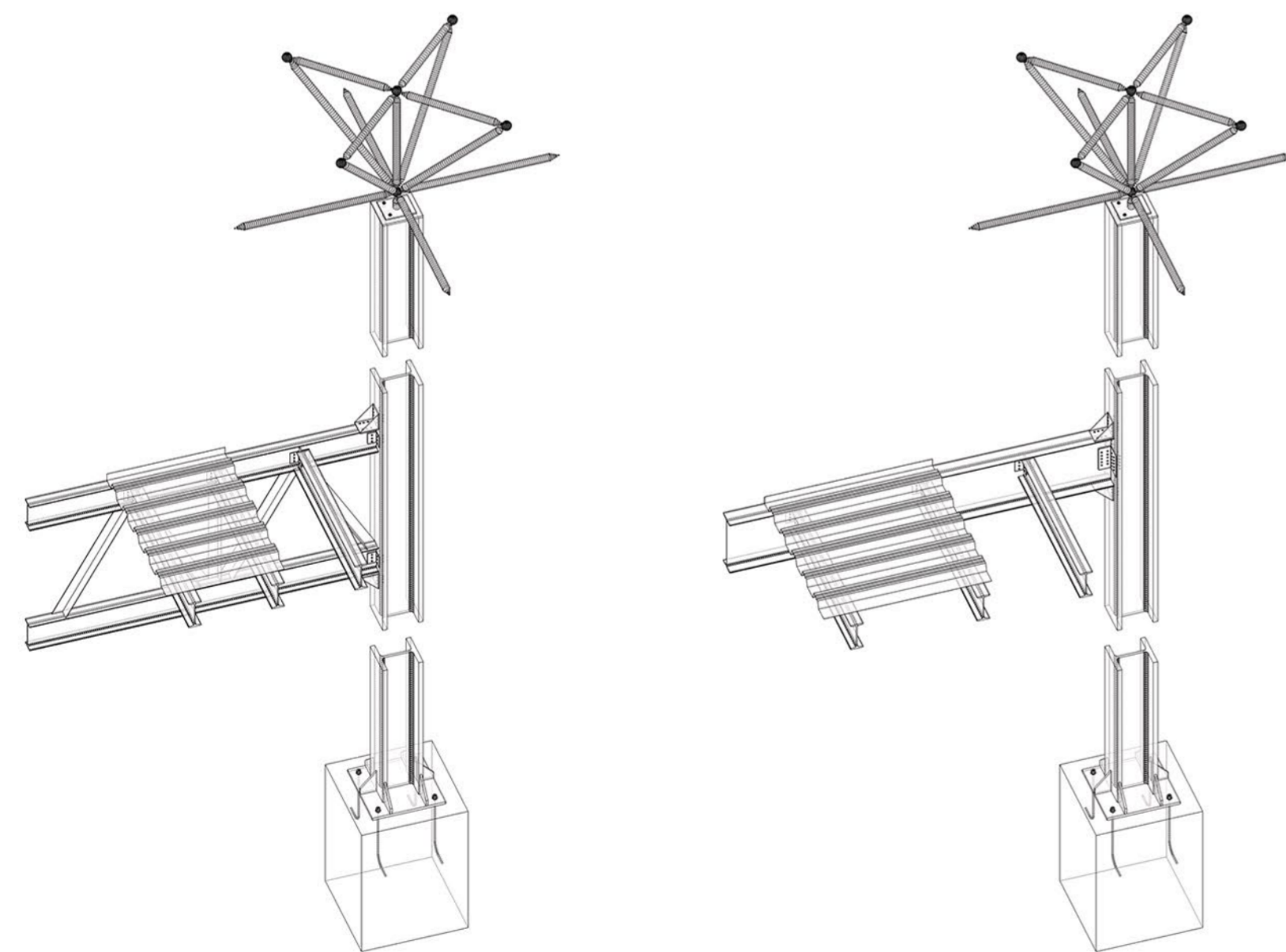

Connection of the truss / beam to the column

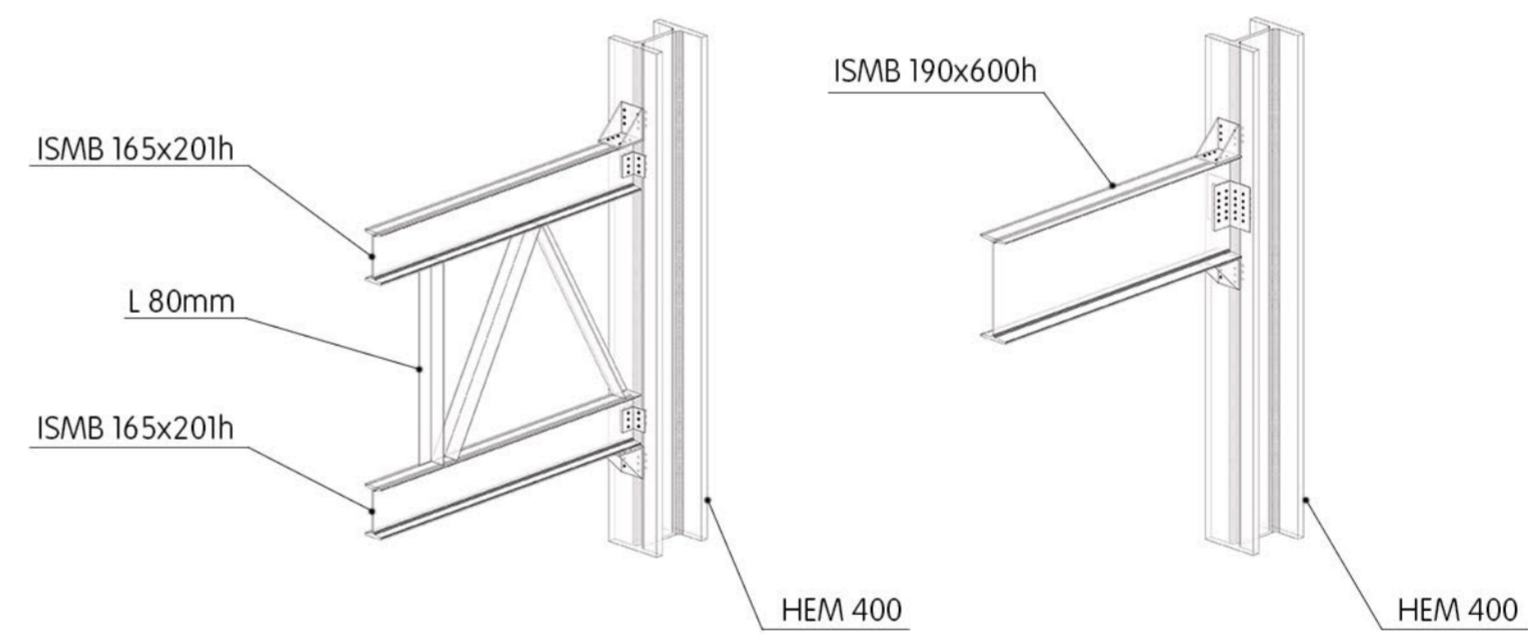

Foundation of HEM column

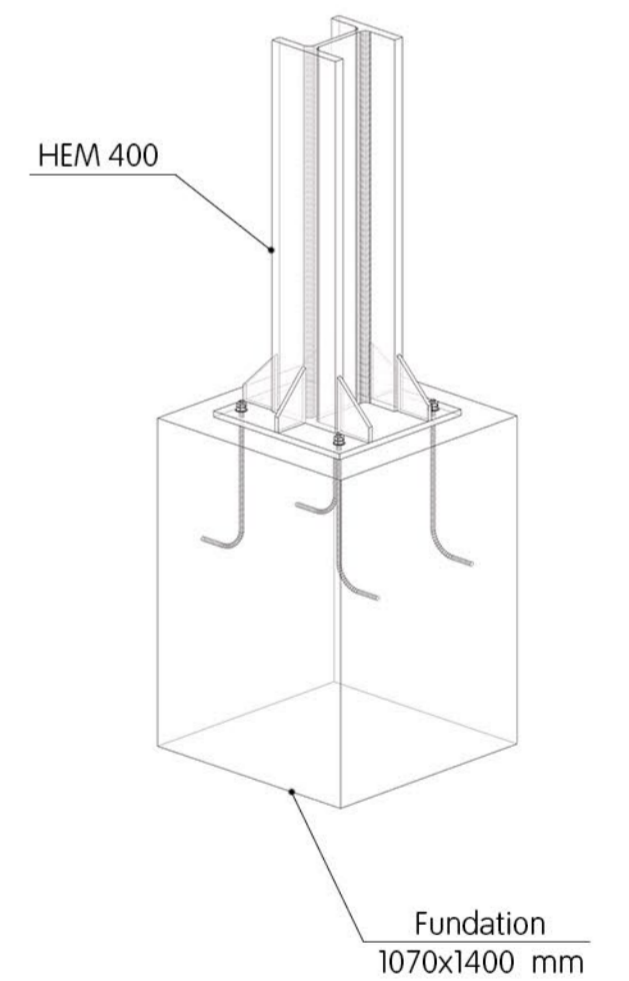

Connection of the secondary beam to the primary

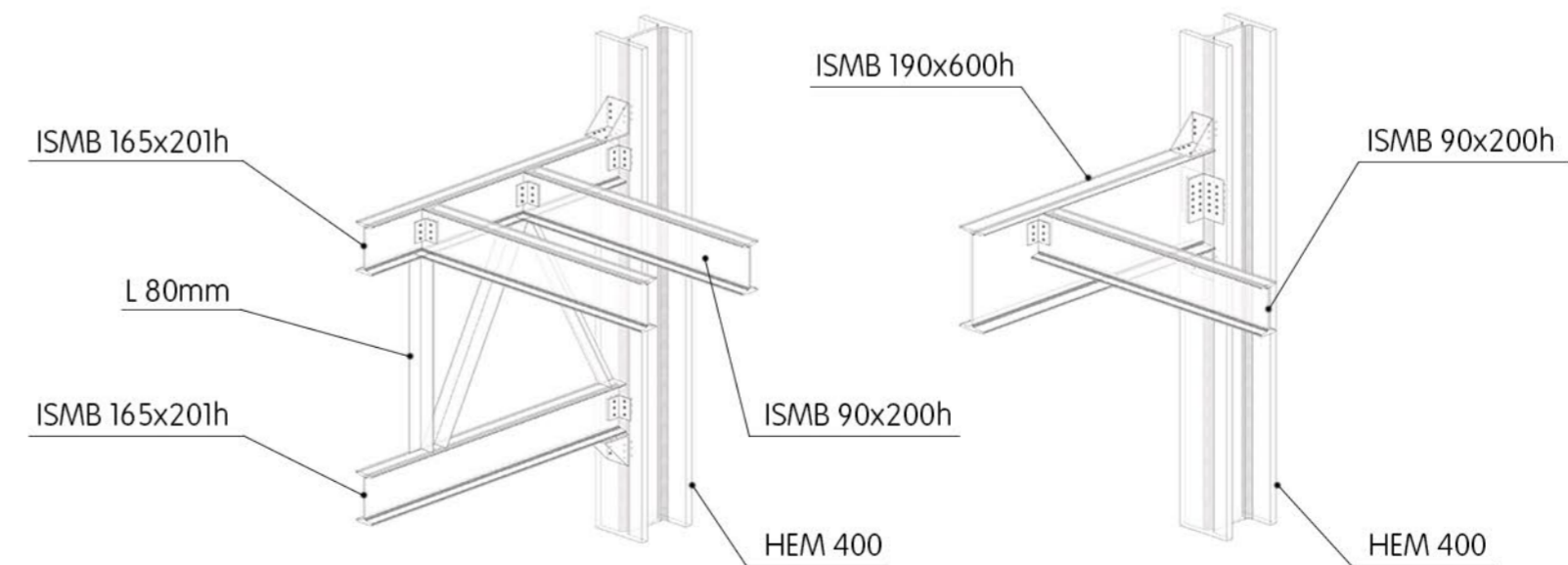

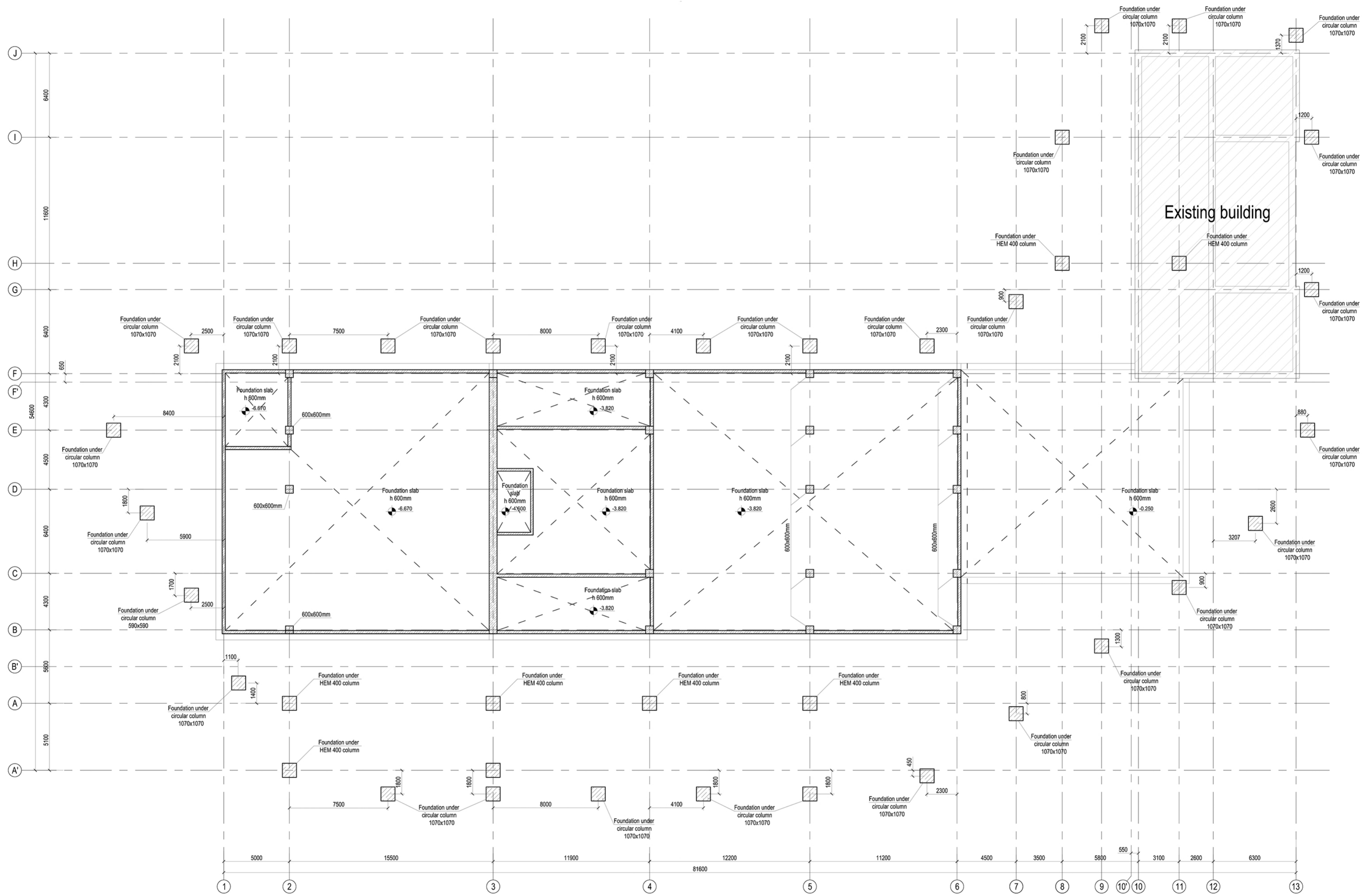

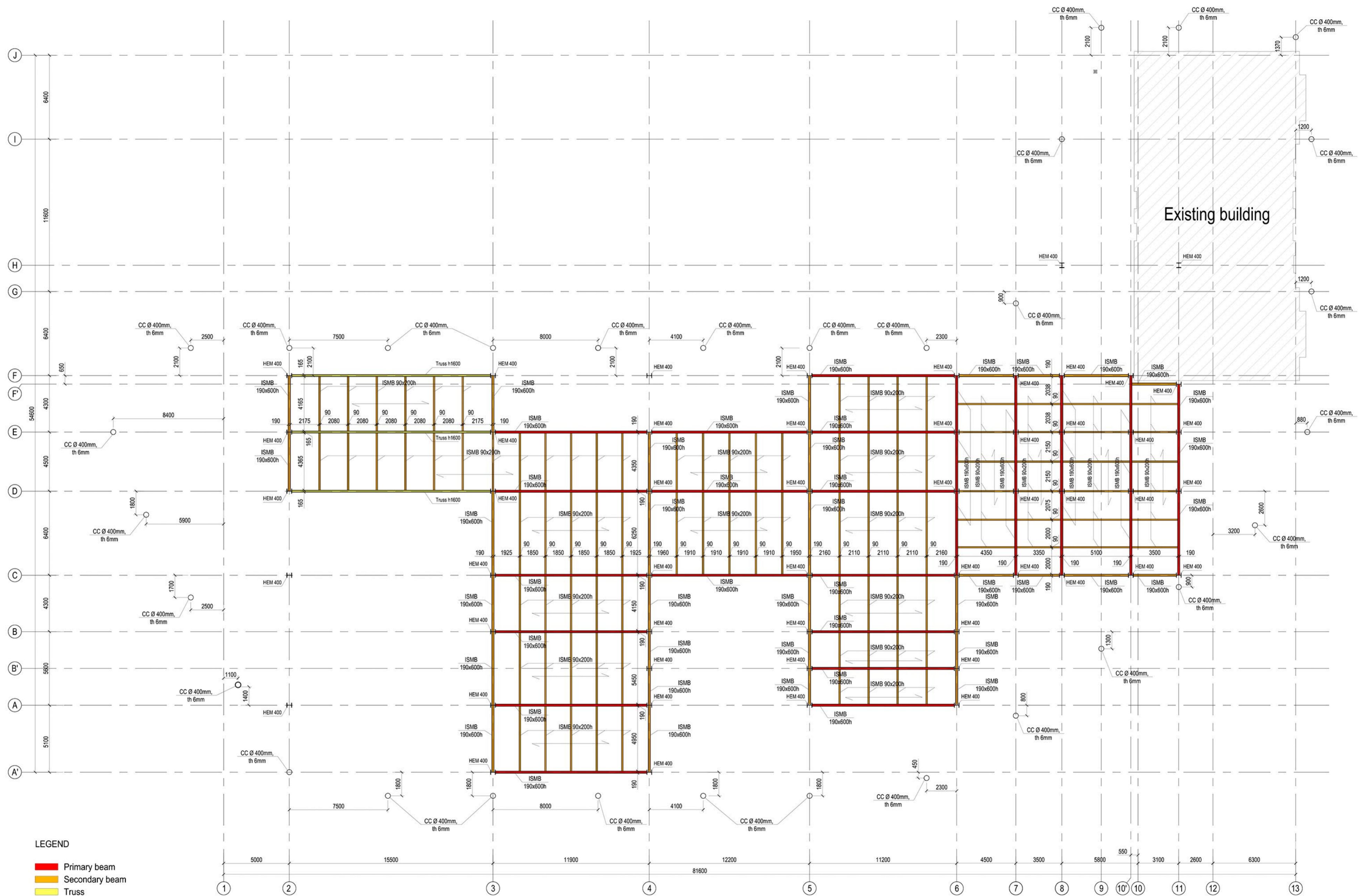

- LEGEND**
- █ Primary beam
 - █ Secondary beam
 - █ Truss



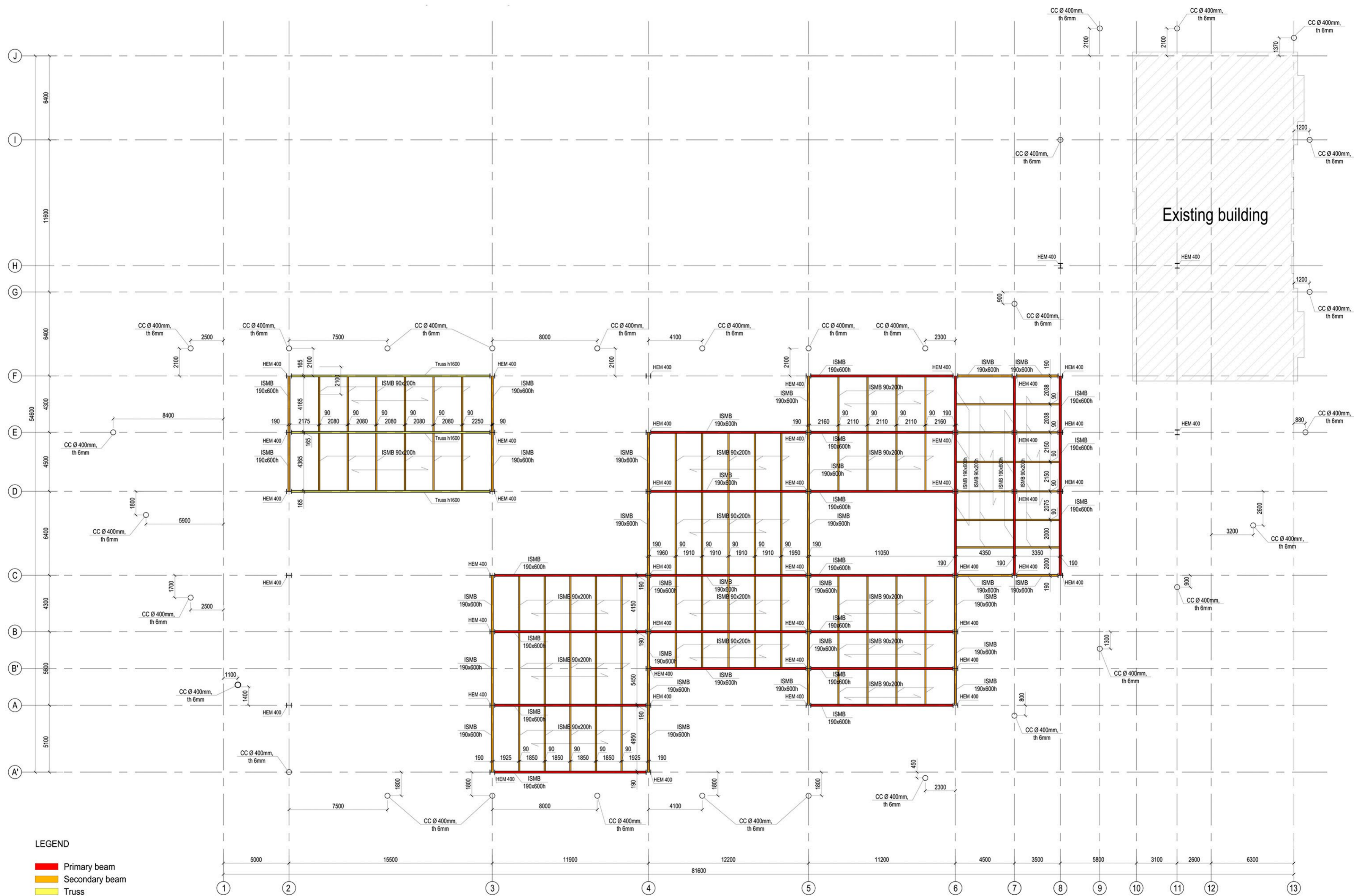

- LEGEND**
- █ Primary beam
 - █ Secondary beam
 - █ Truss



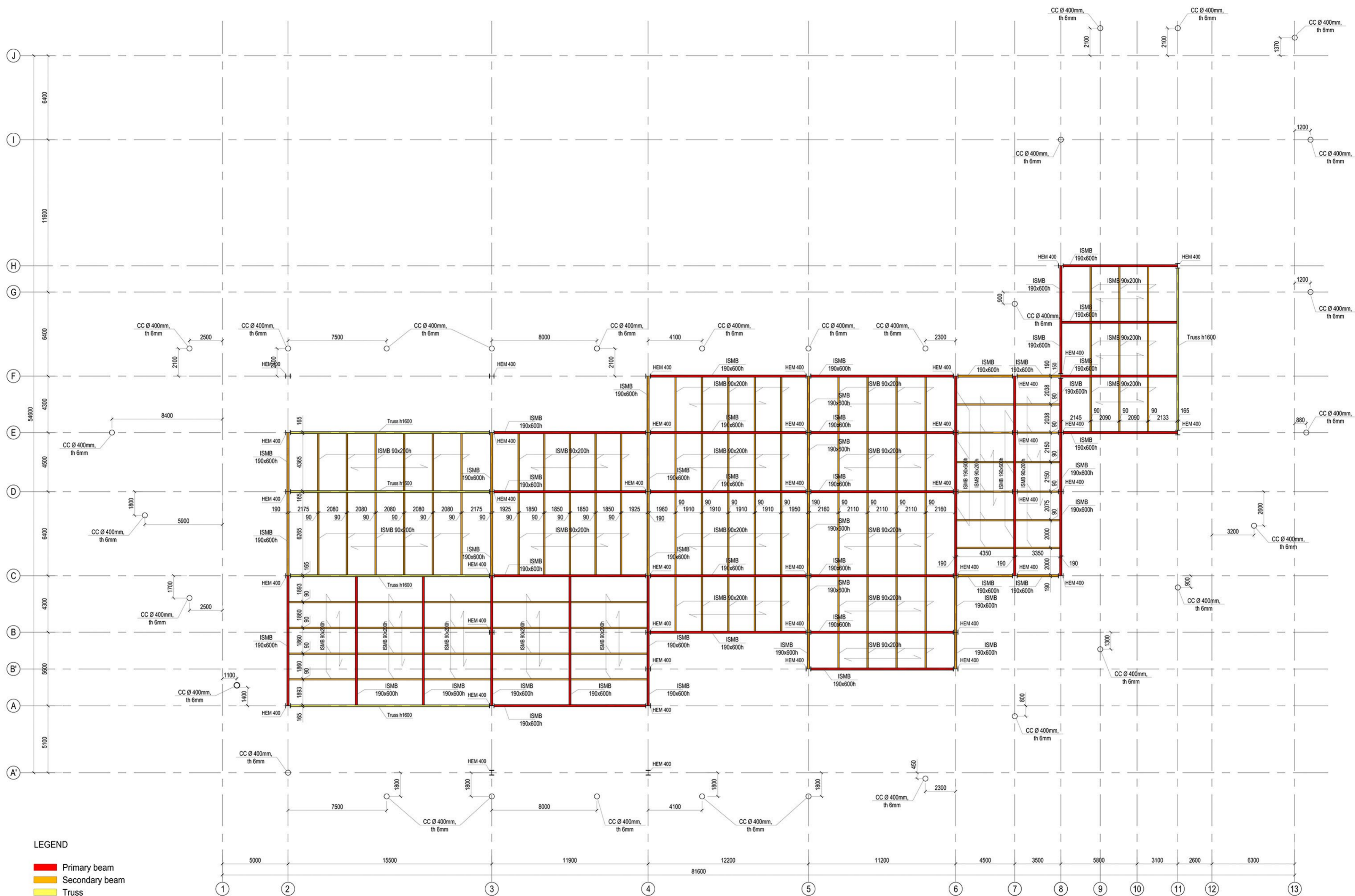

- LEGEND**
- █ Primary beam
 - █ Secondary beam
 - █ Truss



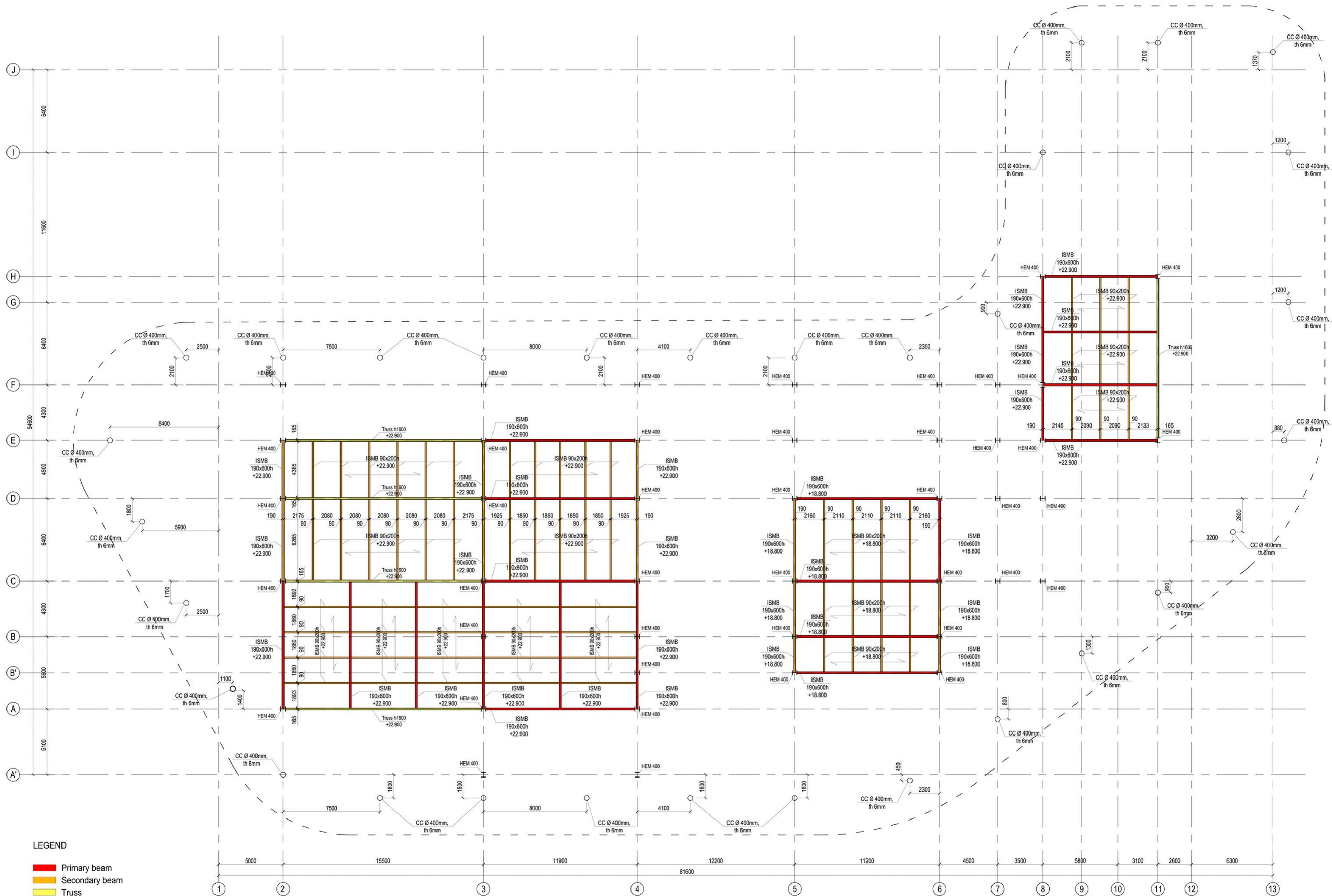

- LEGEND**
- █ Primary beam
 - █ Secondary beam
 - █ Truss



