

MATERIAL

AUTOMATIC WINDOW OPENER CSD600

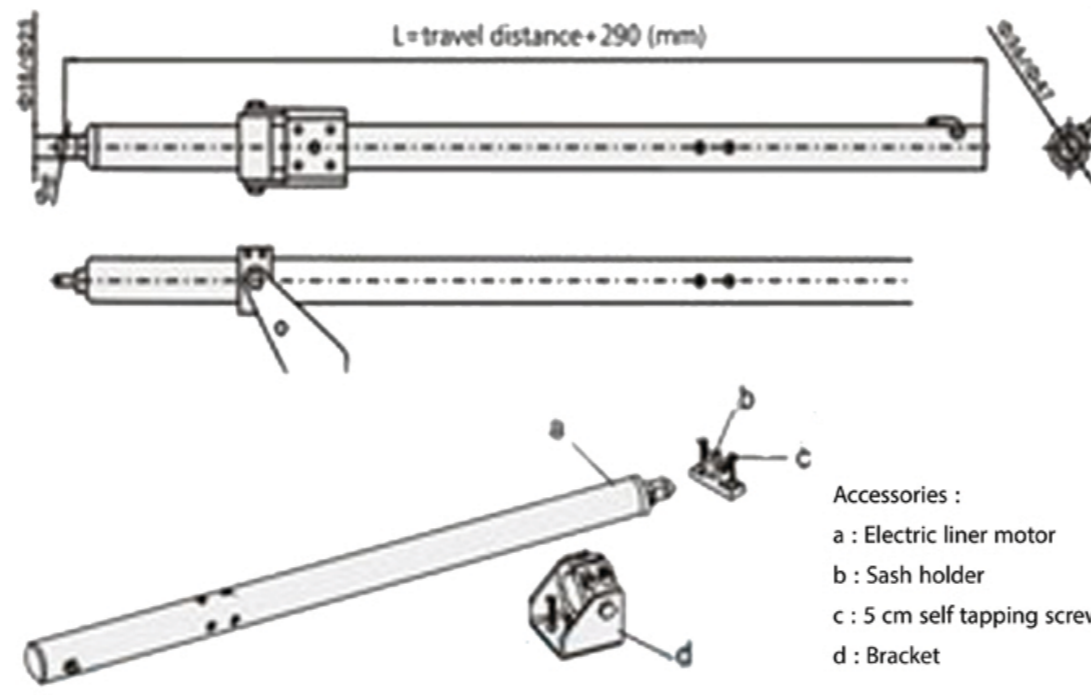

Model	CSD300	CSD500	CSD600
The push and pull force	400N	600N	800N
Max load bearing	40kg	60kg	80kg
Travel distance	300mm	500mm	300/500mm
Speed	8mm/s	7mm/s	7mm/s
Size	455(L)X52(W)X40(H)mm	667(L)X52(W)X40(H)mm	574(L)X35(W)X20(H)mm
Operating power	24V DC		
Degree of protection	42 IP		
Operating ambient Temp.	-10° - +70°		
Material	Housing is made of aluminum alloy, also stainless steel can be customized, chain is made of stainless steel.		

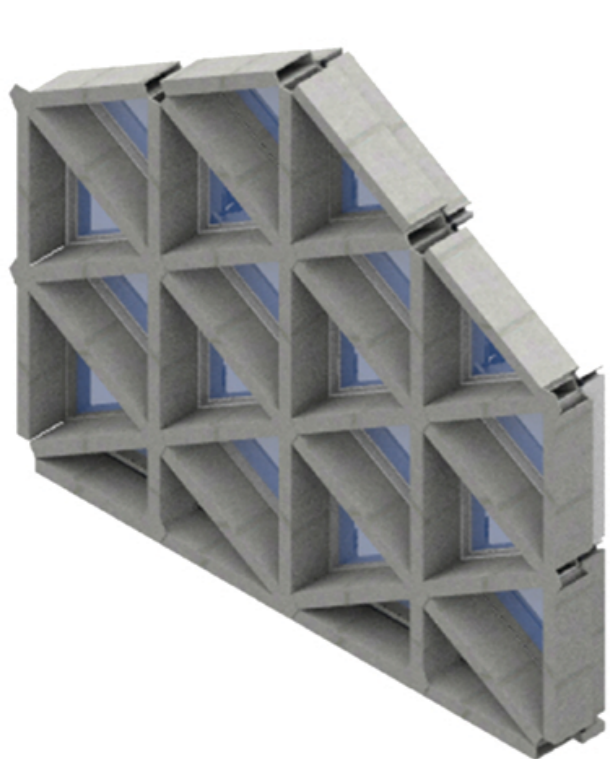

Front Elevation Openness Proportion : Closed

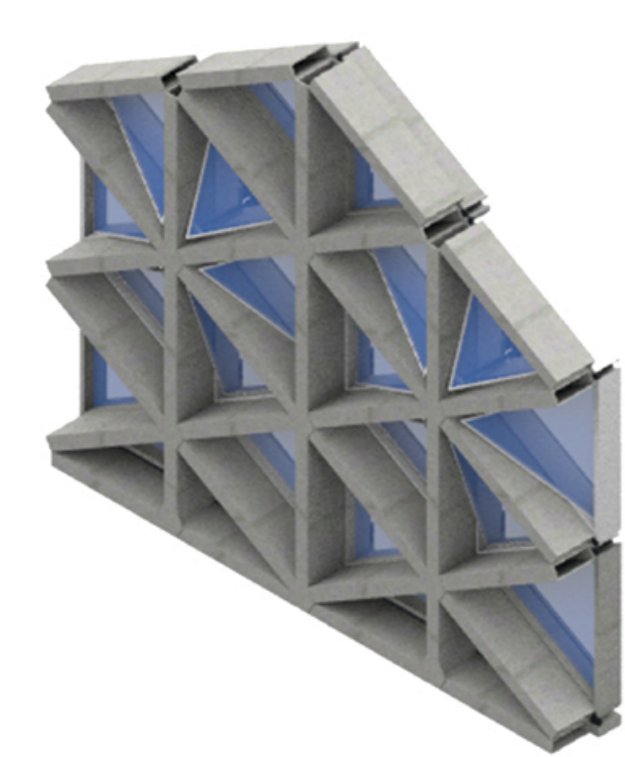
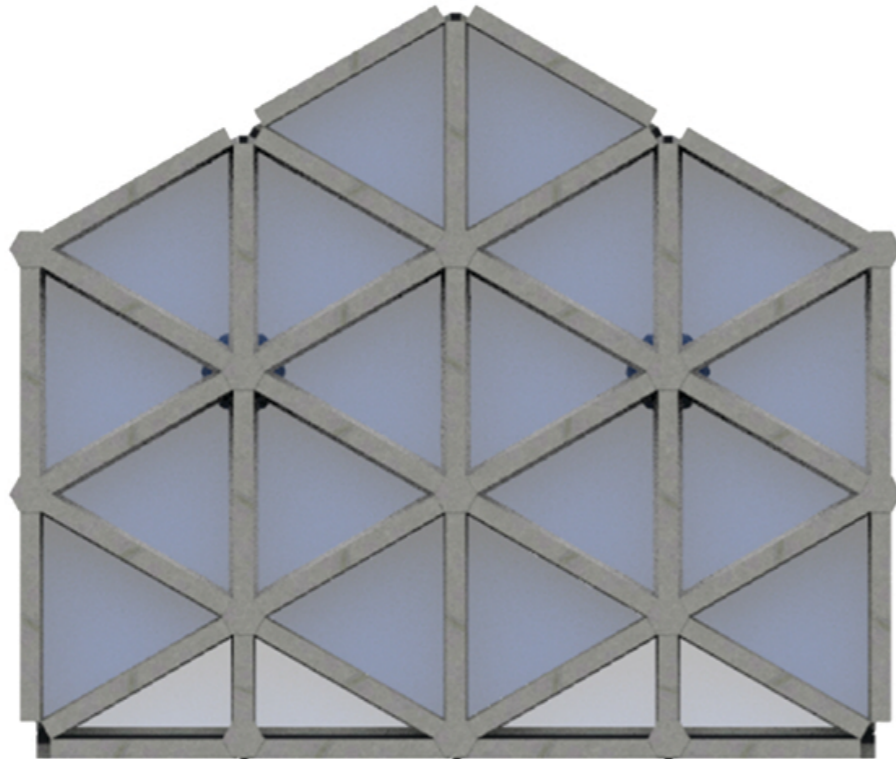

Front Elevation Openness Proportion : 1/3

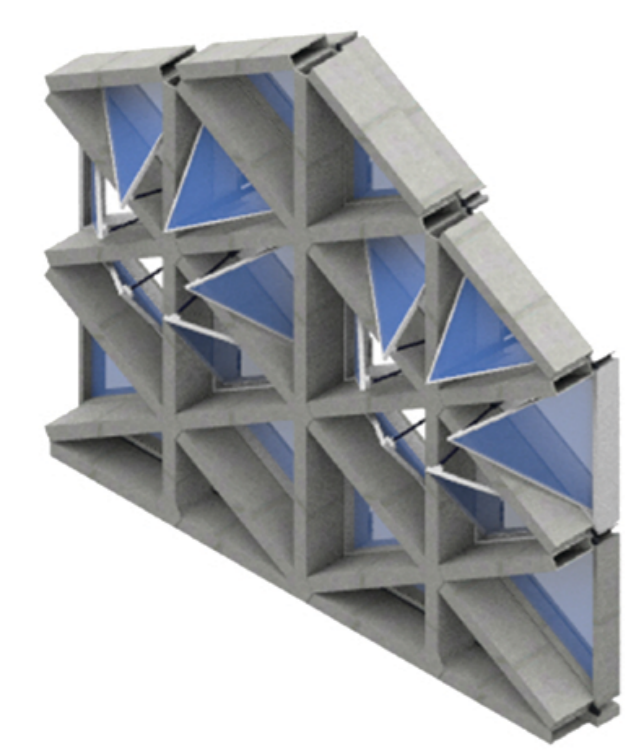
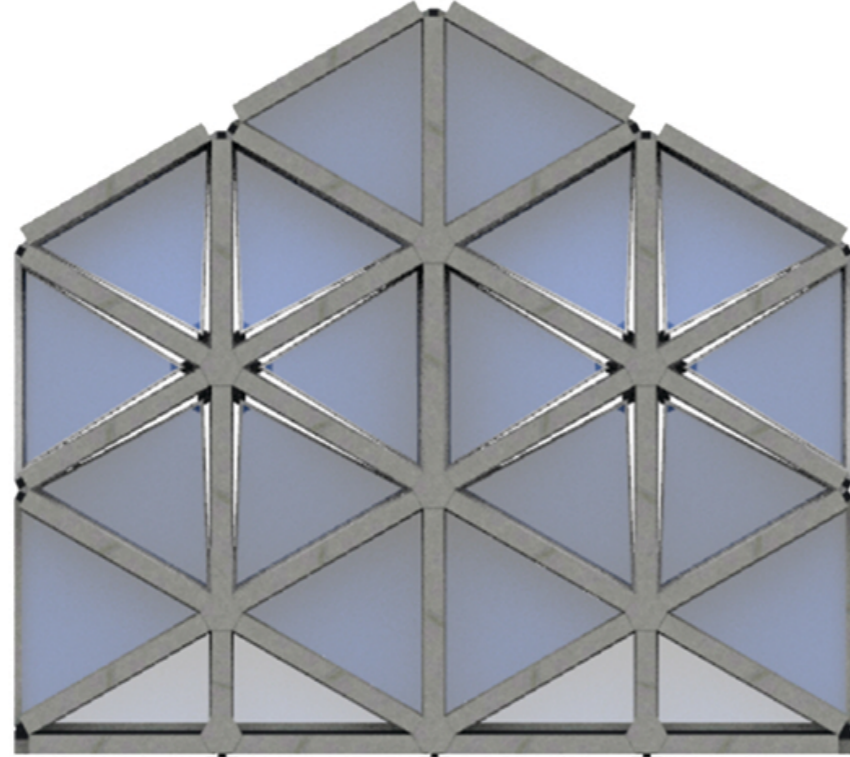

Front Elevation Openness Proportion : 2/3

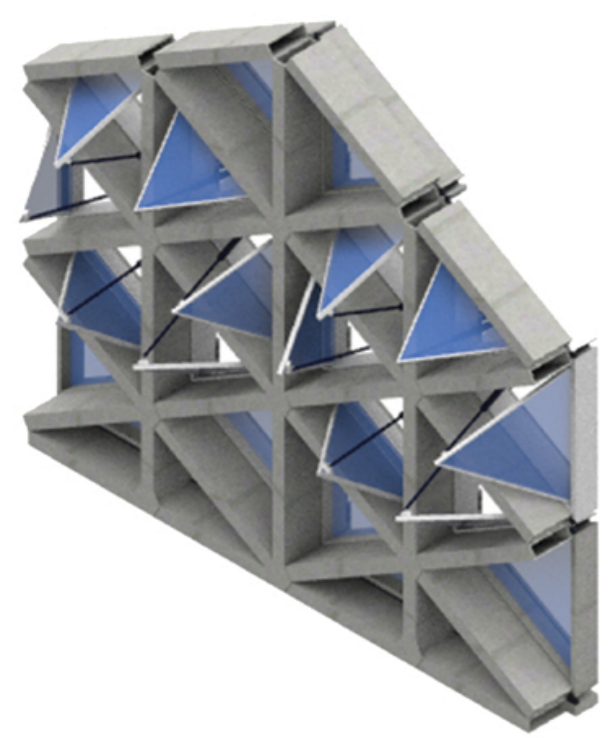
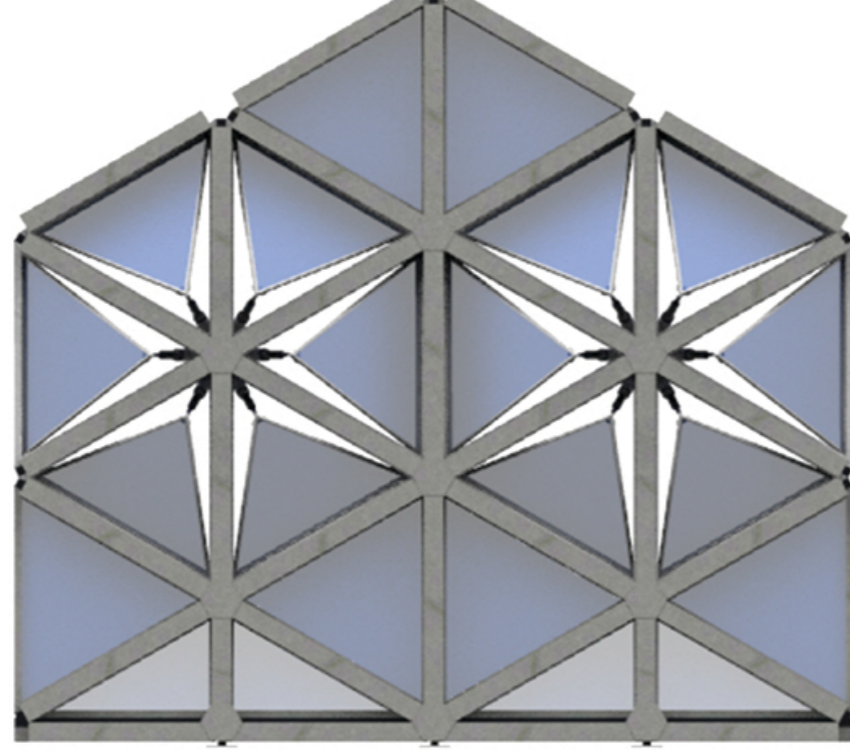

Front Elevation Openness Proportion : Complete

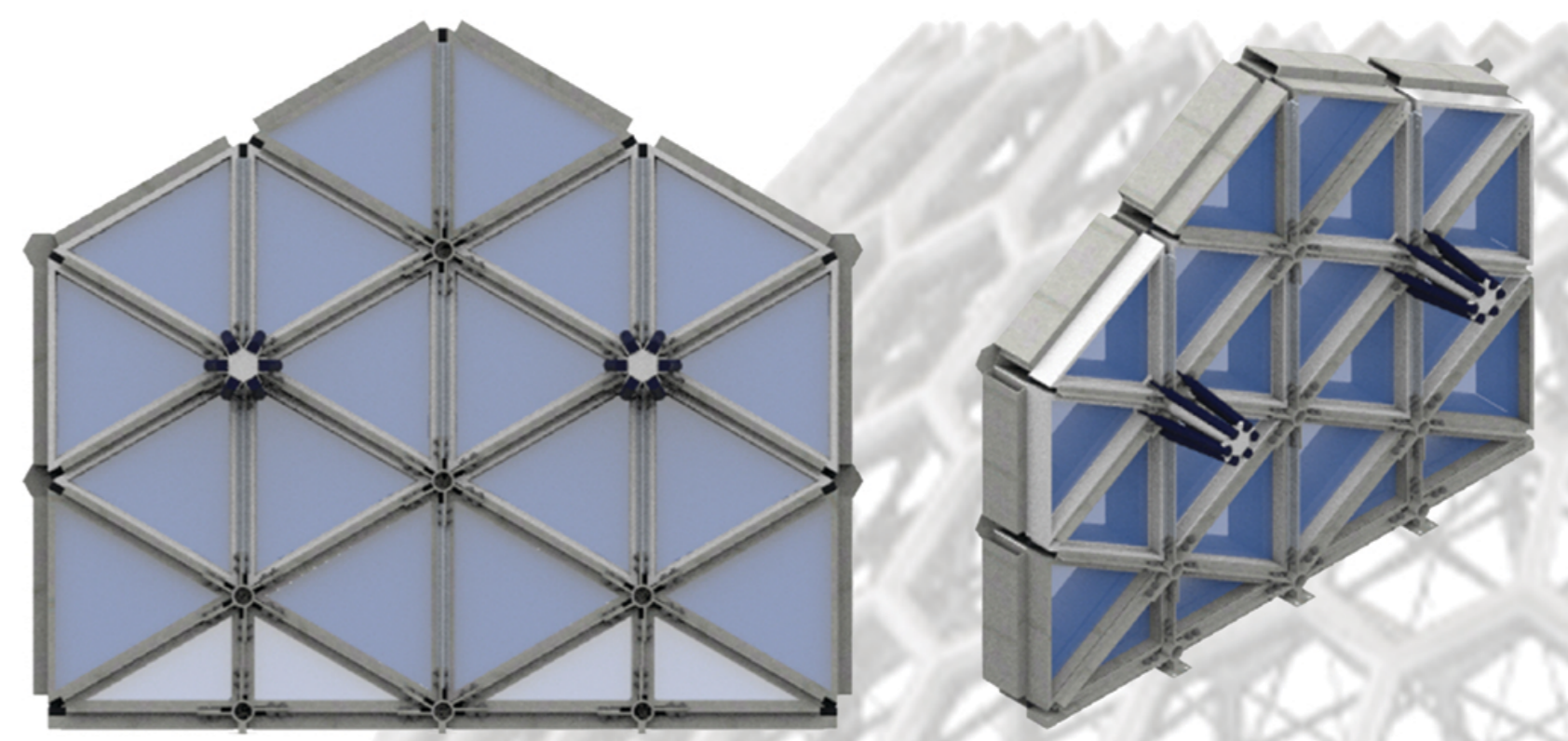
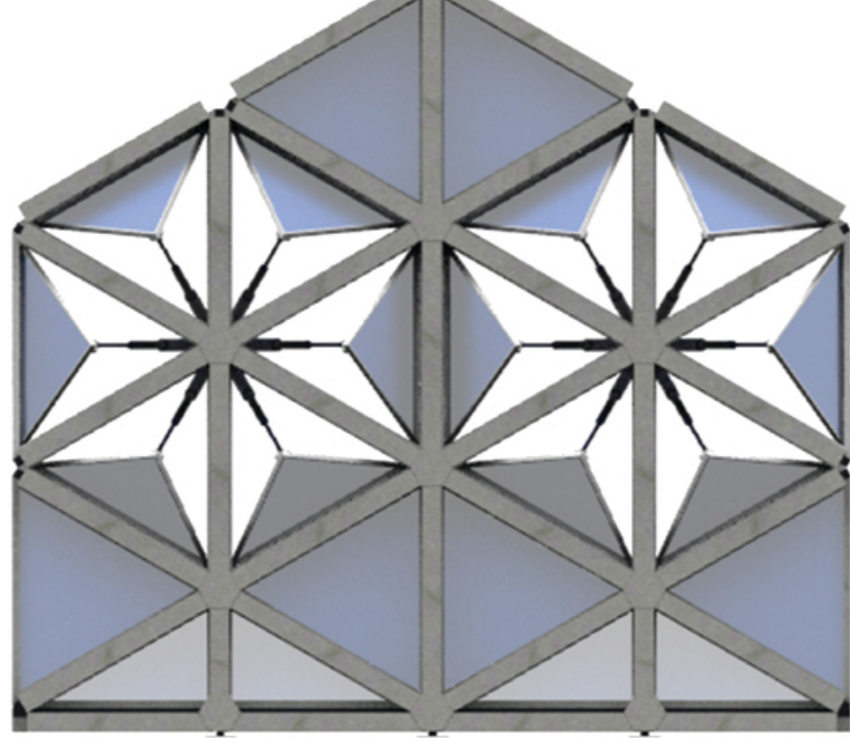

Behind Elevation Openness Proportion : Closed

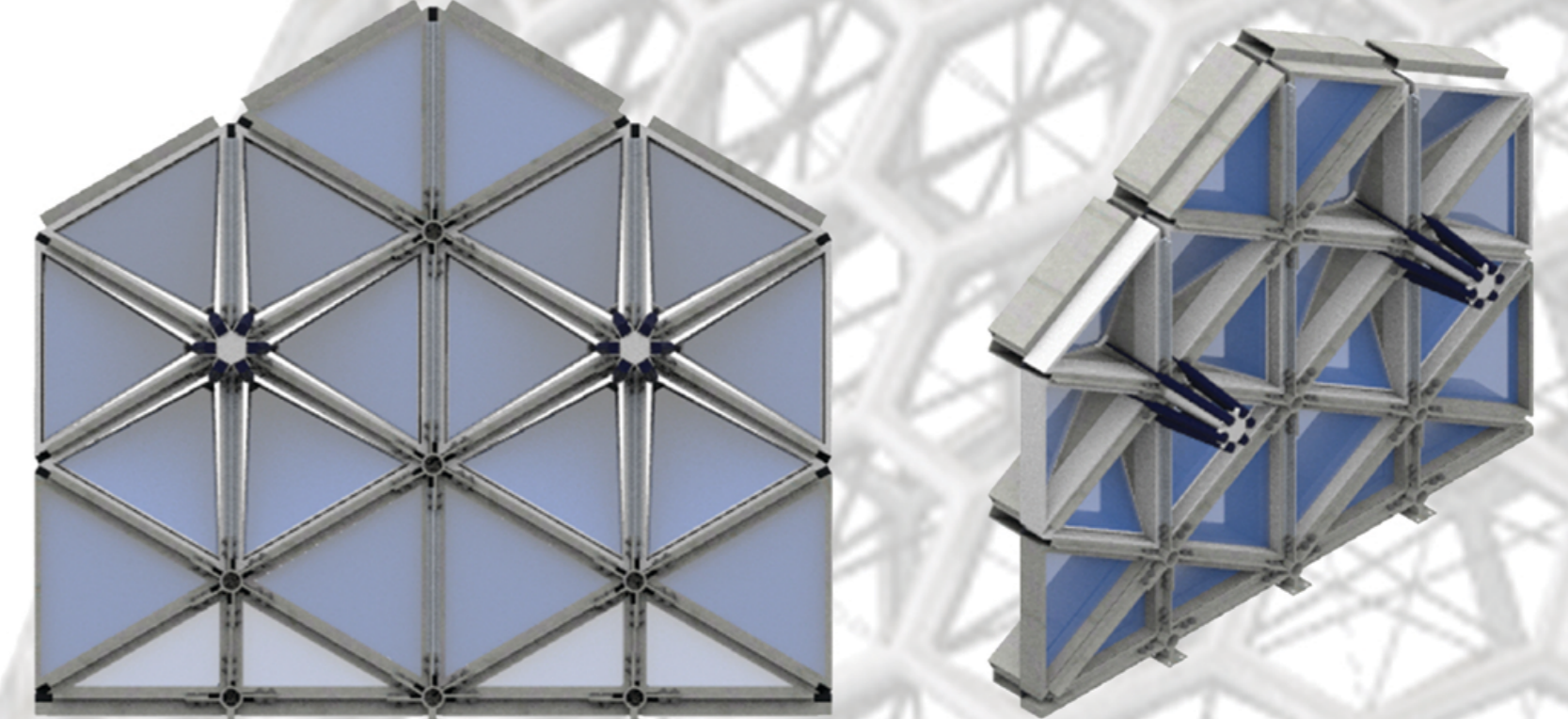

Behind Elevation Openness Proportion : 1/3

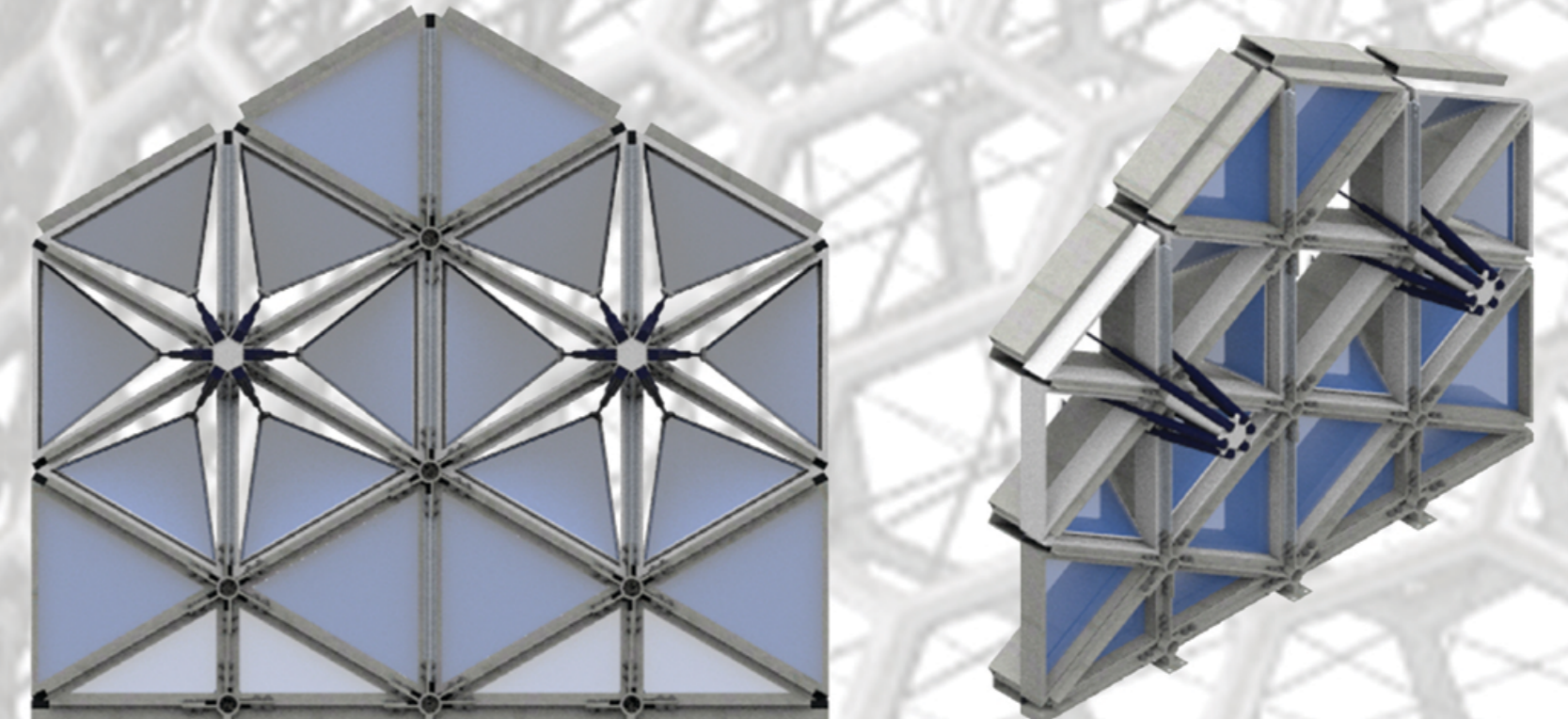

Behind Elevation Openness Proportion : 2/3

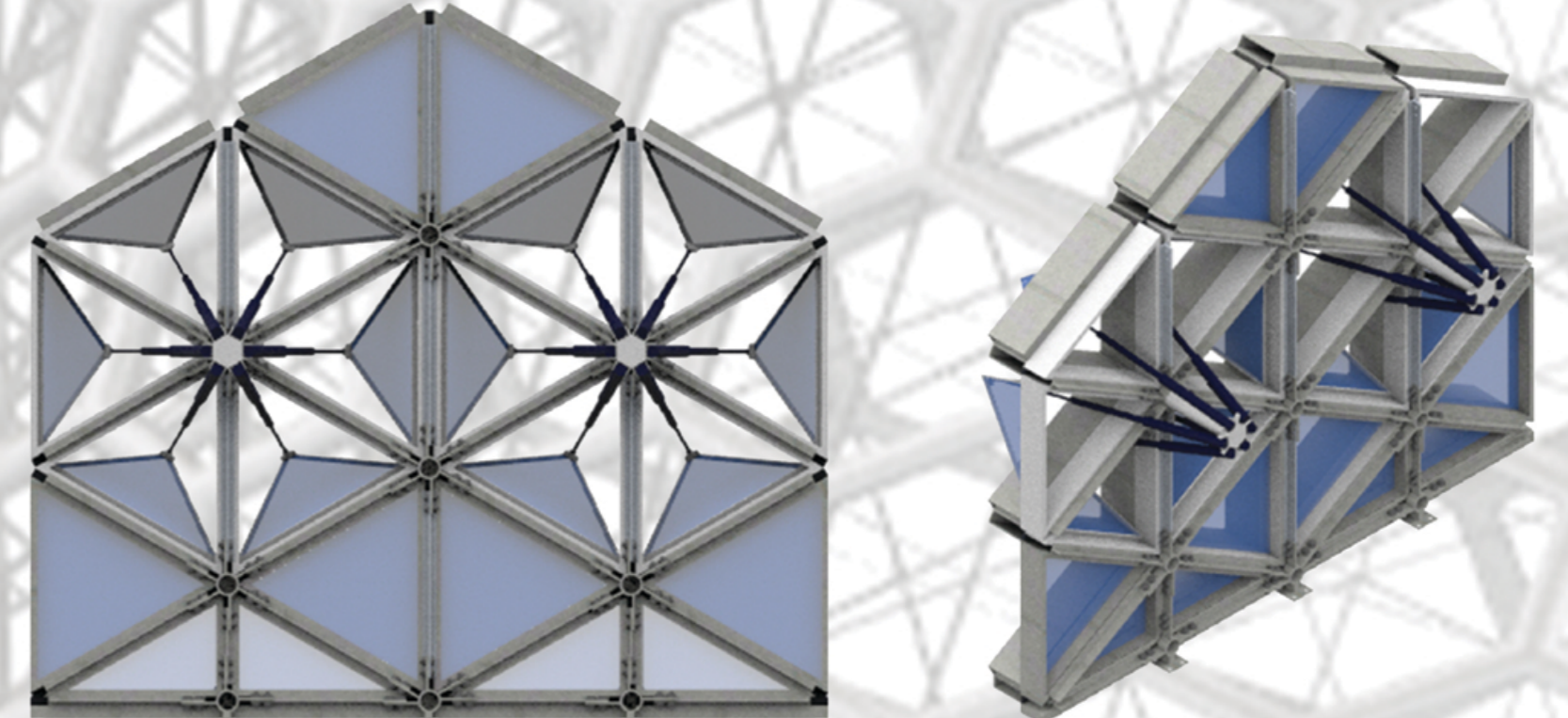

Behind Elevation Openness Proportion : Complete

PRODUCT FEATURES

1. Rebuilt overloading protection system, in case the sudden high electric current make the motor burning
2. Max travel distance 800mm (can be customized) is very suitable for all kinds of windows, especially the big skylight and smoke vent.
3. Stainless steel rod is high anti-corrosion, even in the high temperature and moisture environment, the window opener can last long service life.
4. Travel distance and color can be customized, we can meet different demands from kinds of customers.
5. More than thousands of pushing and pulling test, HTHP test, salt spray test, etc. ensure the thirty thousand smoothly push and pull to the opener.
6. Centralized controller for fire, Vent centralized controller, Central controller for wind & rain. Remote centralized controller for window open & close in the whole building can all be customized. Just one press, the whole building windows can be controlled.



Fine and easy installed hardware fitting



High anti-acid aluminium alloy housing

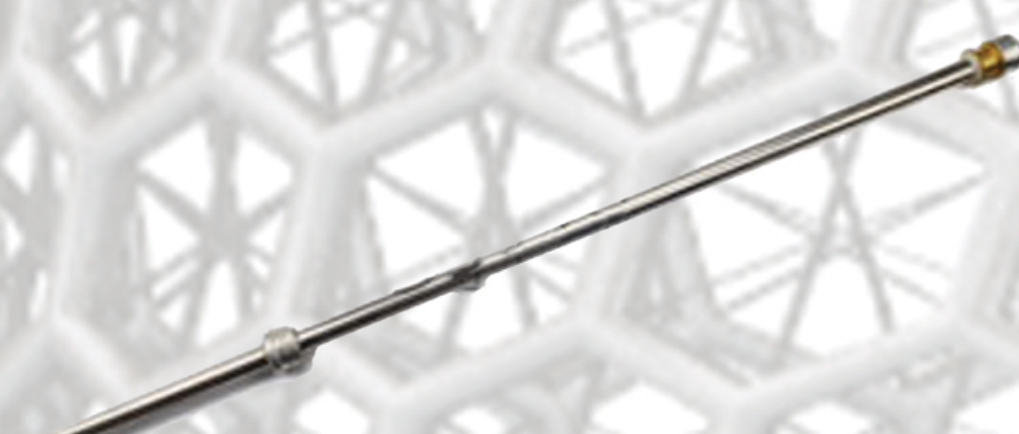

Long travel distance



Retractable screw window opener

