

# MATERIAL

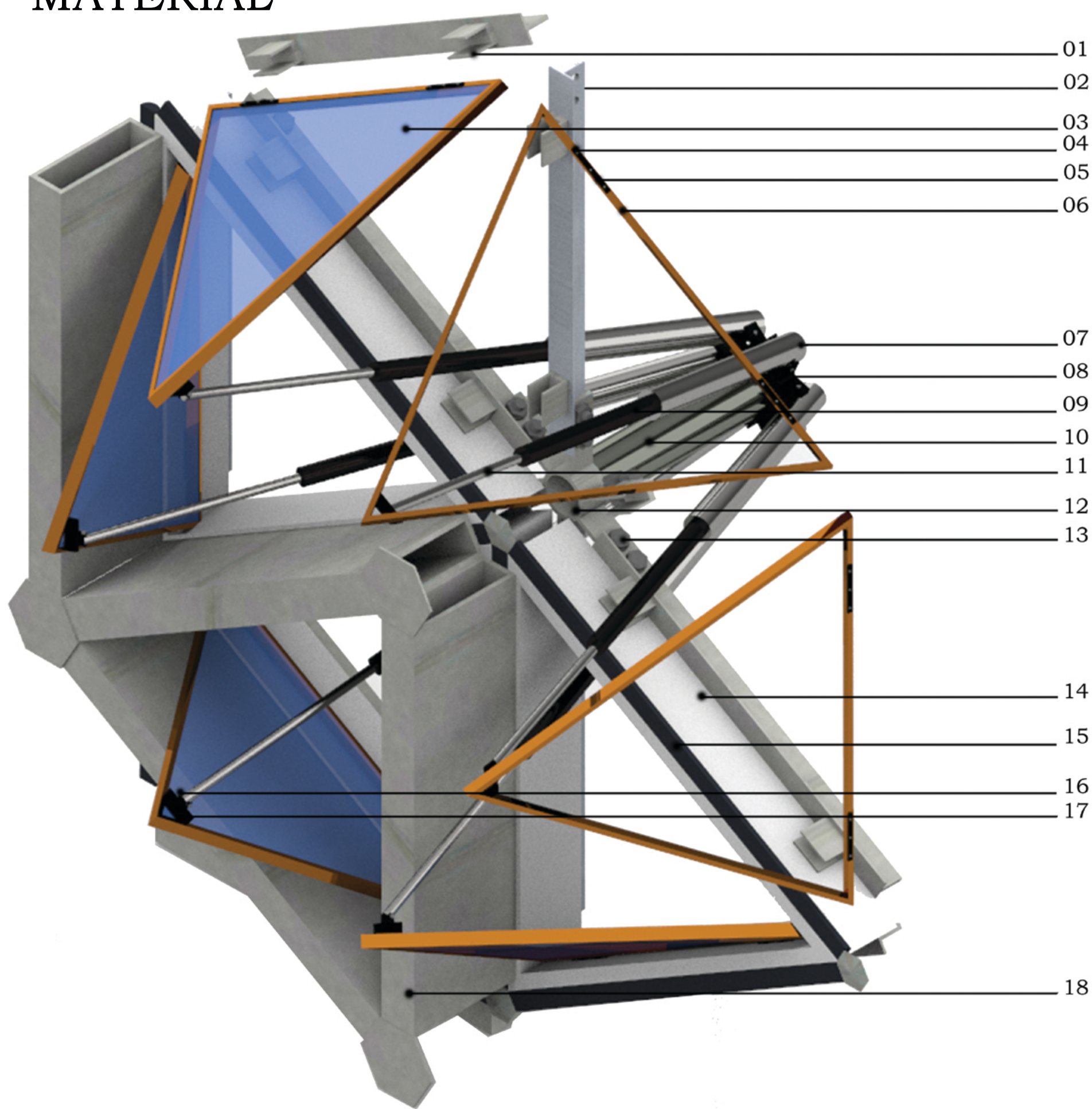

## MAIN COMPONENTS :

1. Profile Joints
2. Profile
3. Sun Screen Glass
4. Frame Screws
5. Frame Joints
6. Sun Screen Frame
7. Electric Linier Motor
8. Motor Holder
9. Motor Leg n.1
10. Motor connector to Profile
11. Motor Leg n.2
12. Profile Connector
13. Profile Screws
14. Glass Packet Profile
15. Rubber
16. Slash Holder
17. Bracket
18. Fcade Profile

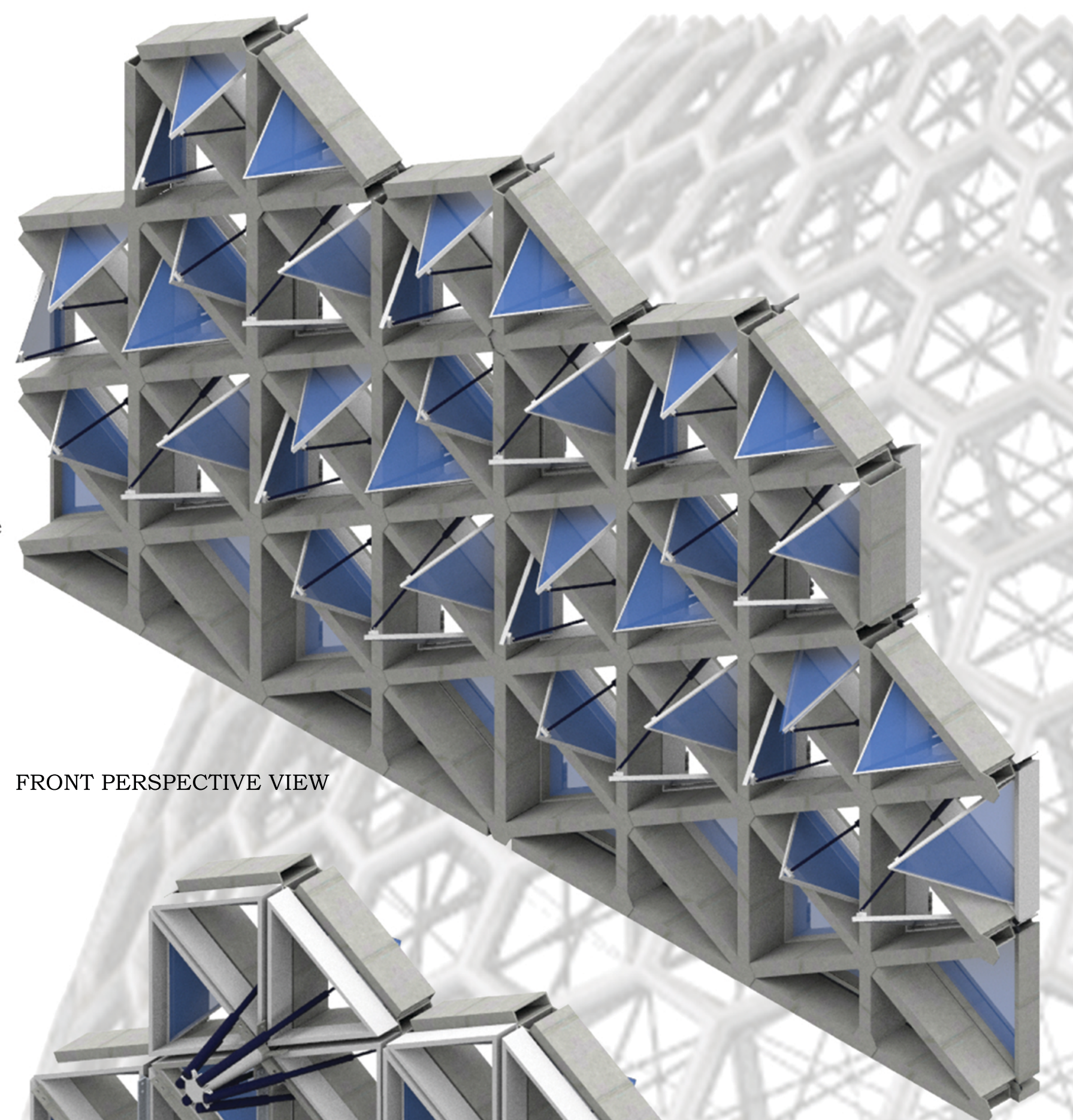

FRONT PERSPECTIVE VIEW

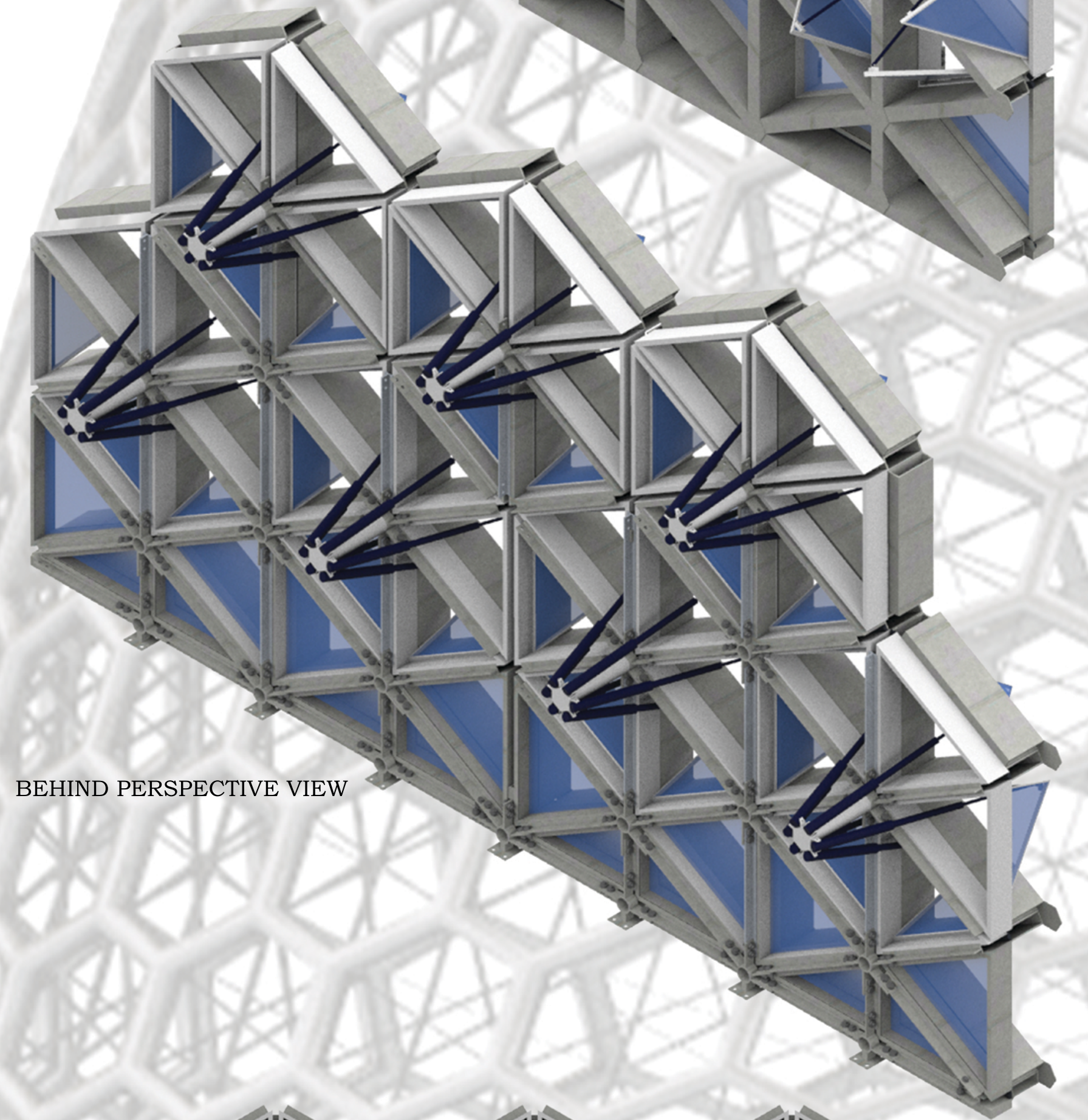

BEHIND PERSPECTIVE VIEW



MOTOR PERSPECTIVE VIEW

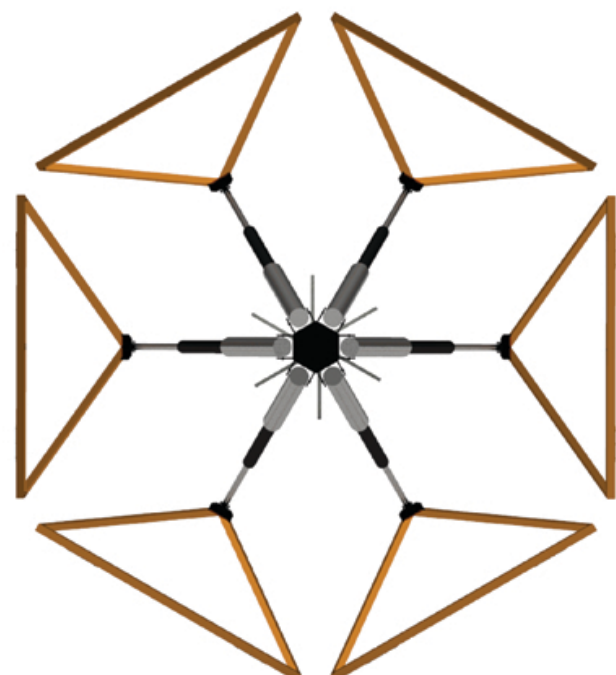

OPENNESS PROPORTION : COMPLETE

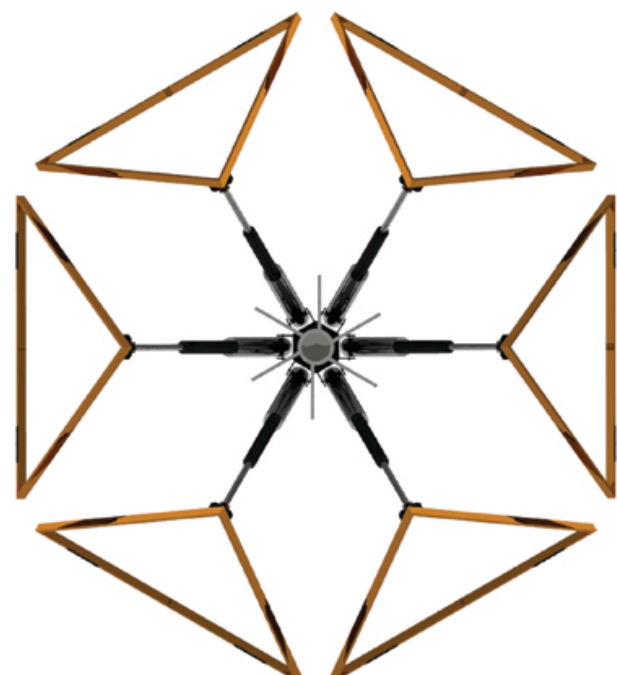

MOTOR PERSPECTIVE VIEW

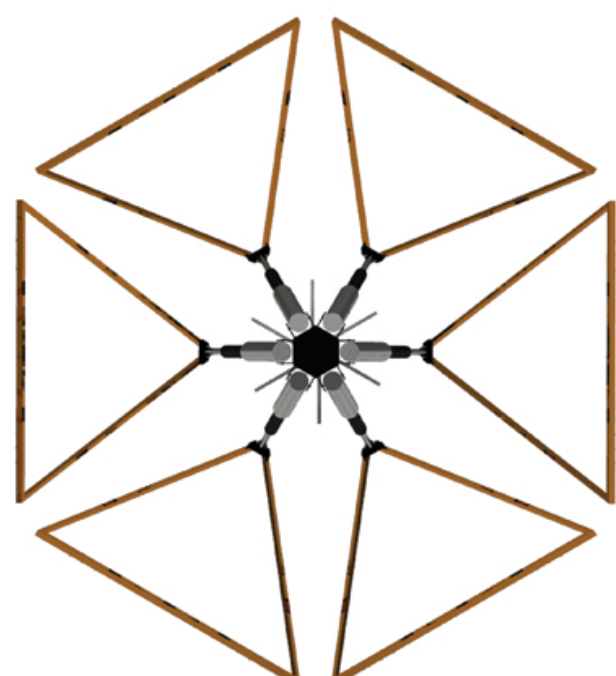

OPENNESS PROPORTION : 2/3 OPEN

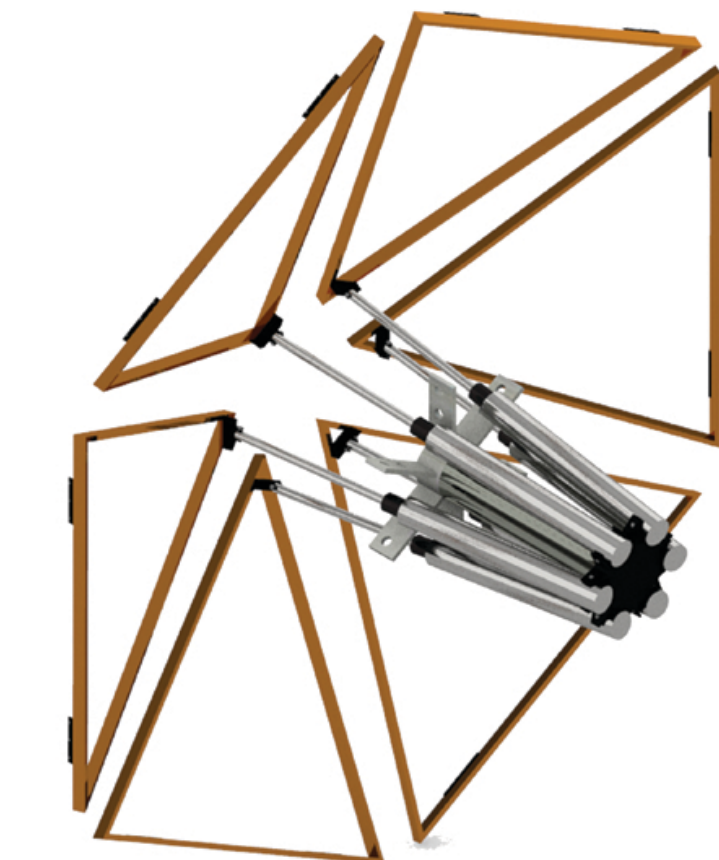
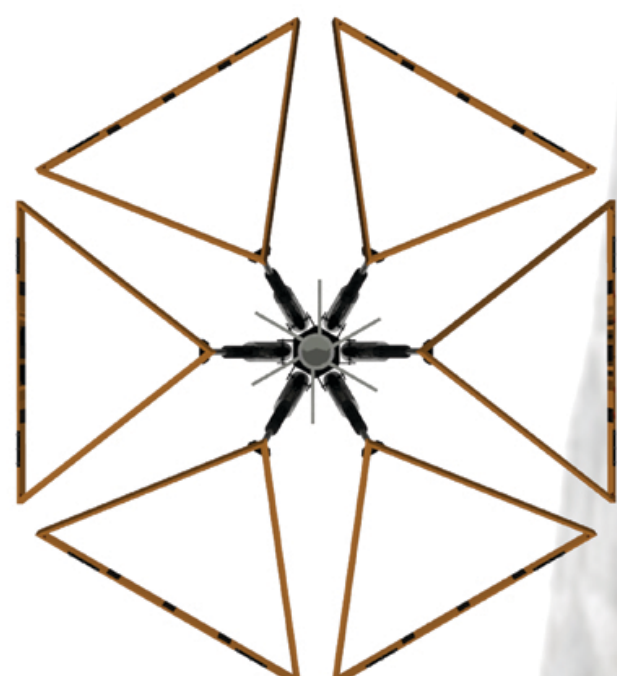

MOTOR PERSPECTIVE VIEW

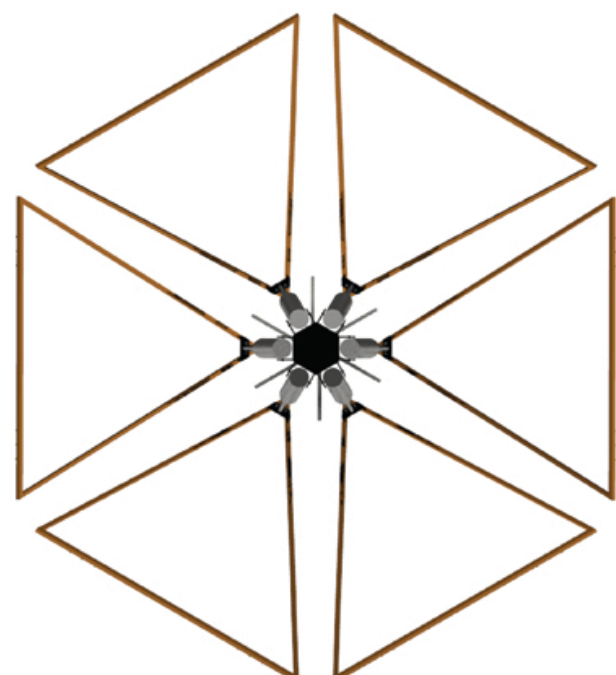

OPENNESS PROPORTION : 1/3 OPEN

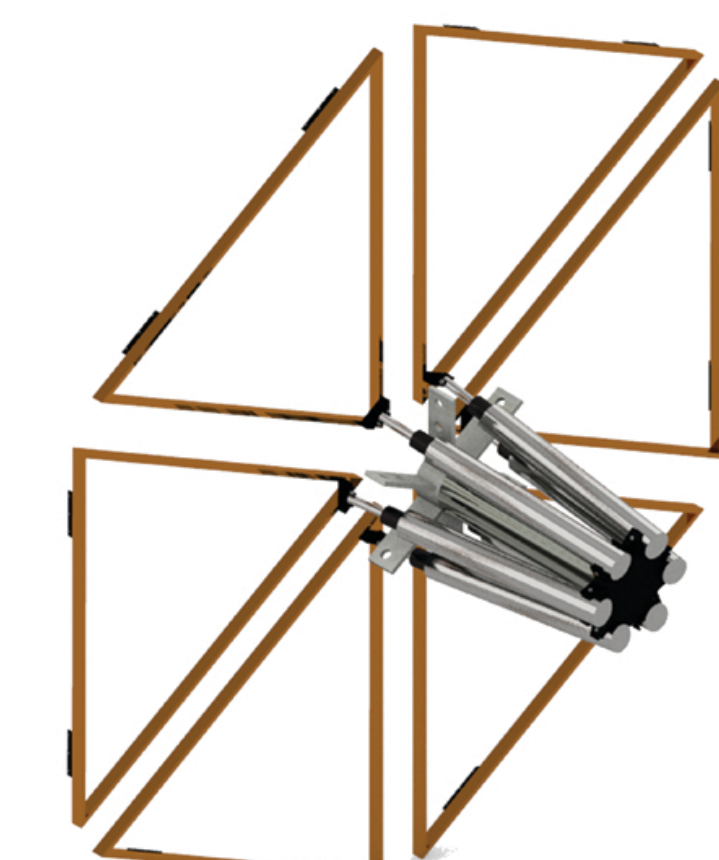
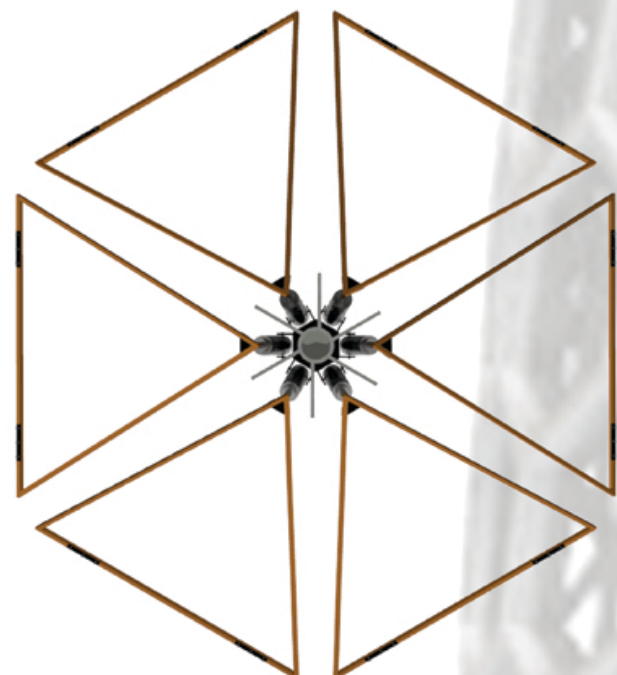

MOTOR PERSPECTIVE VIEW

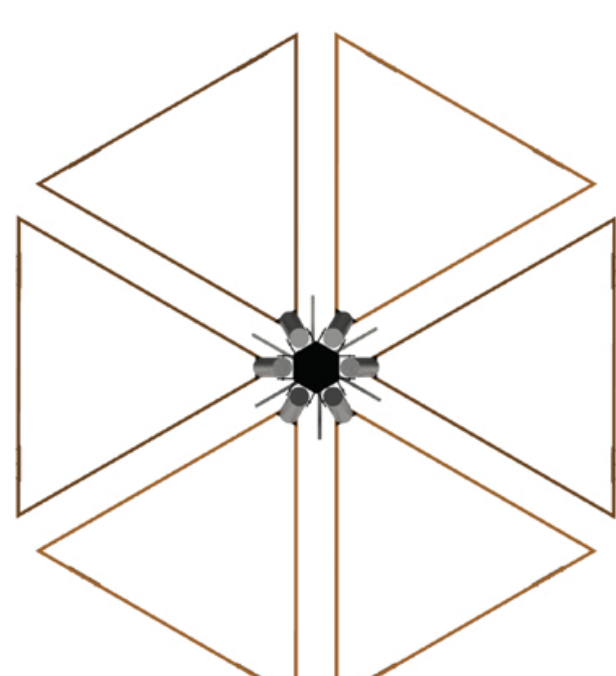

OPENNESS PROPORTION : CLOSED

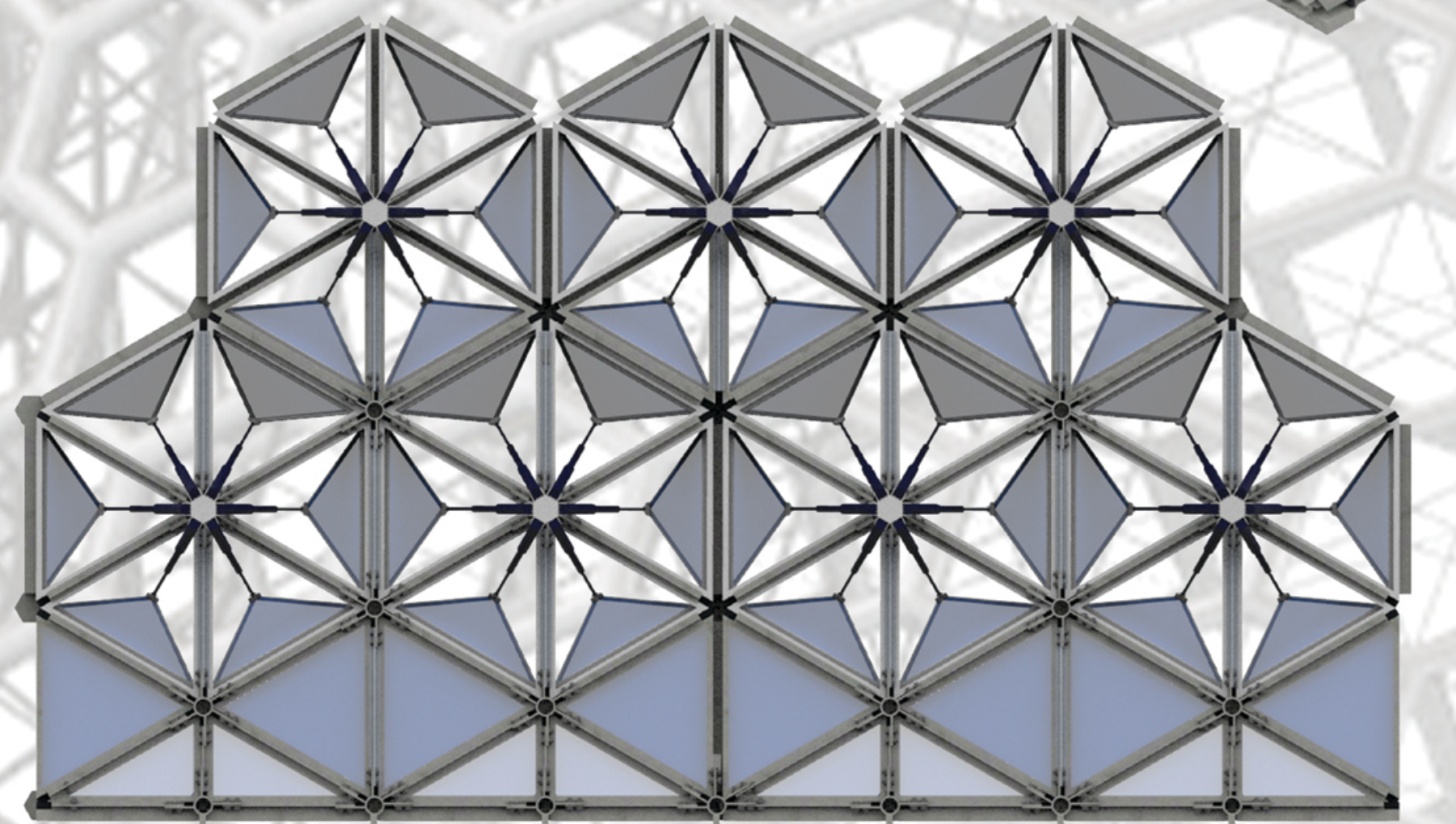
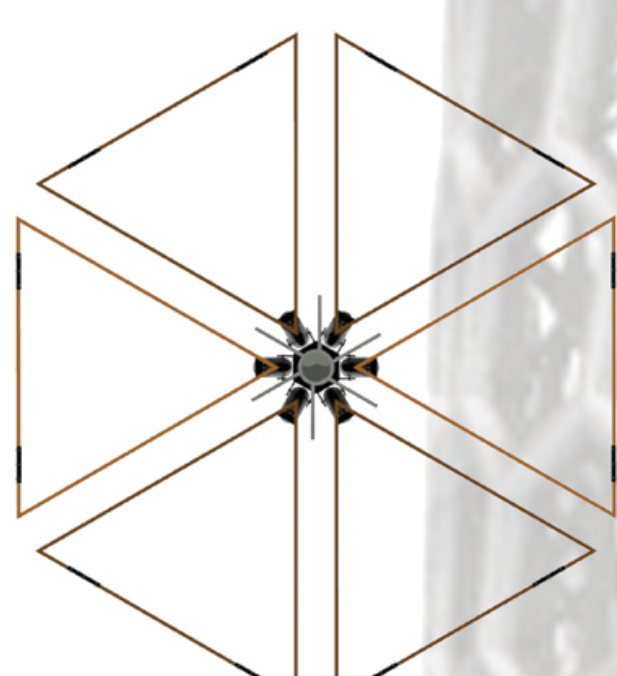

BEHIND ELEVATION

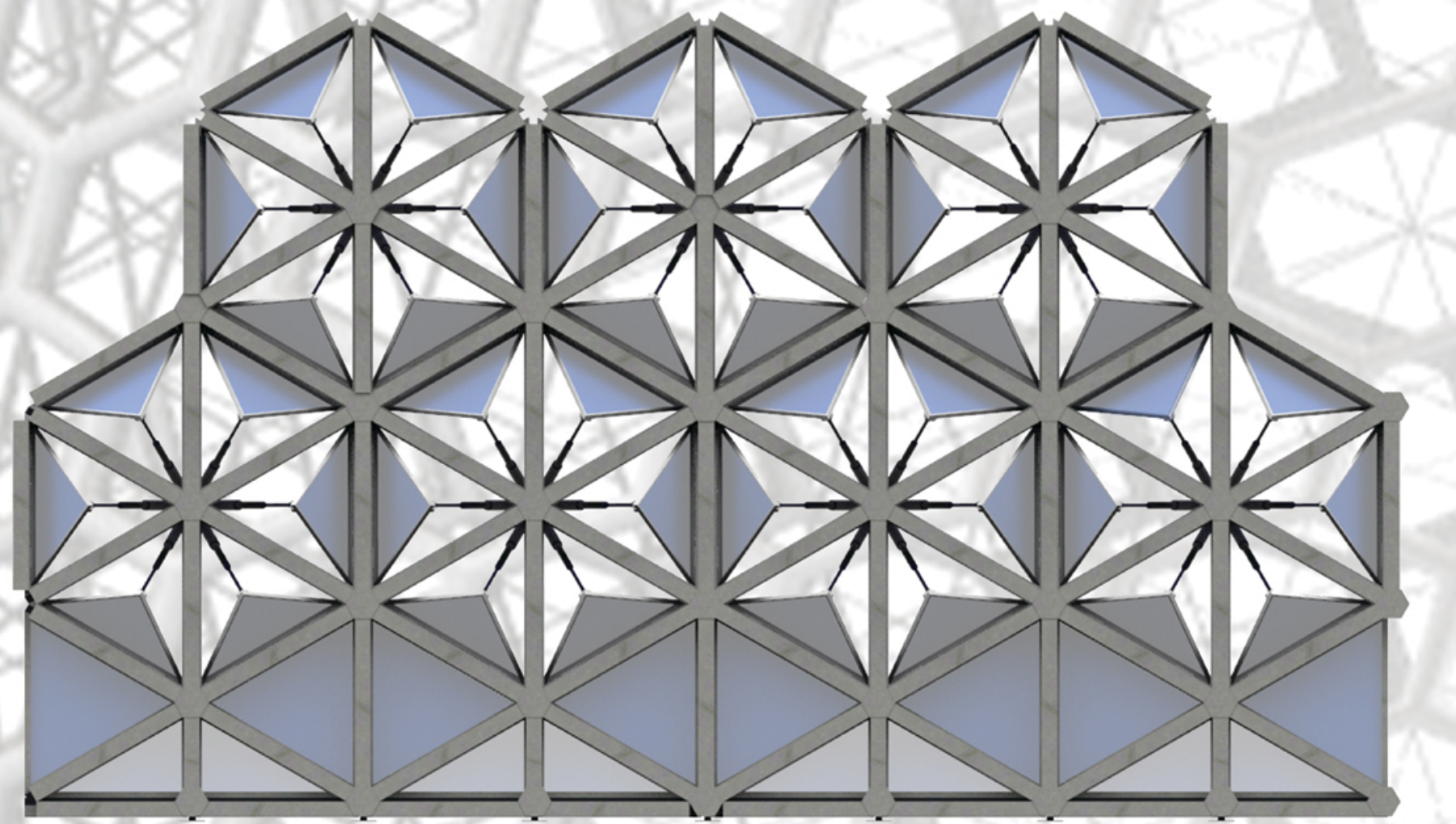

FRONT ELEVATION

