



POLITECNICO
MILANO 1863

SCUOLA DI INGEGNERIA INDUSTRIALE
E DELL'INFORMAZIONE

Lithium-ion Batteries: Challenges, Performance and Applications.

TESI DI LAUREA MAGISTRALE IN
ELECTRICAL ENGINEERING
INGEGNERIA ELETTRICO

Author: Nicole El Khoury Mikhael

Student ID: 10959072
Advisor: Prof. Marco Faifer
Academic Year: 2024-25

Abstract

This study represents a full overview of Lithium-ion Batteries (LIBs), focusing on their chemistry and materials, types, electric parameters, problems, applications, and environmental effects. After comparing the primary, secondary, and special battery, the study shows that lithium-ion batteries are the leading and the most effective energy storage technology currently, because of their high energy density and power density. Different types of LIBs are examined in this study, such as LCO, LFP, NMC, NCA, LMO, and LTO, in terms of electrical properties, temperature tolerances, safety, efficiency, and lifecycle. Moreover, the study includes a cost breakdown of the LIB throughout the whole process, starting from the raw material to the recycling. In addition to covering critical topics such as thermal runaway and safety risks of the LIB, and a detailed comparison of lithium-ion batteries with lithium solid-state batteries. Furthermore, it investigates the presence of LIBs in various applications, such as electric vehicles, grid-scale energy storage, residential energy storage, and consumer electronics. The carbon footprint of various LIBs is discussed in this review, and it is measured using a lifecycle assessment, which shows that recycling helps in decreasing carbon emissions, while mining and manufacturing steps are the main source of carbon emissions. Finally, the hybridization of lithium-ion batteries with supercapacitors, was discussed and implemented. Along with its comparison with the hybridization of the solid-state batteries with supercapacitors.

Keywords: Lithium-ion batteries (LIBs), Energy storage, Battery performance, Battery safety, lifecycle assessment (LCA), Carbon footprint, Solid-state batteries, Hybrid battery systems, Electric vehicles (EVs), Renewable energy storage.

Abstract in italiano

Questo studio rappresenta una panoramica completa delle batterie agli ioni di litio (LIB), con un focus sulla loro chimica e sui materiali, sui tipi, sui parametri elettrici, sui problemi, sulle applicazioni e sugli effetti ambientali. Dopo un confronto tra batterie primarie, secondarie e speciali, lo studio dimostra che le batterie agli ioni di litio sono attualmente la tecnologia di accumulo energetico più avanzata ed efficace, grazie alla loro elevata densità energetica e densità di potenza. Nello studio vengono analizzati diversi tipi di LIB, come LCO, LFP, NMC, NCA, LMO e LTO, in termini di proprietà elettriche, tolleranze termiche, sicurezza, efficienza e ciclo di vita. Inoltre, viene presentata un'analisi dettagliata dei costi delle LIB lungo l'intero processo, dalla materia prima al riciclo. Lo studio affronta anche temi critici come il fenomeno del thermal runaway e i rischi per la sicurezza delle LIB, includendo un confronto approfondito tra batterie agli ioni di litio e batterie al litio allo stato solido. Viene inoltre esaminato l'impiego delle LIB in diverse applicazioni, come veicoli elettrici, accumulo di energia su scala di rete, accumulo domestico e dispositivi elettronici di consumo. L'impronta di carbonio delle varie LIB è discussa e valutata tramite un'analisi del ciclo di vita, che evidenzia come il riciclo contribuisca alla riduzione delle emissioni, mentre le fasi di estrazione e produzione rappresentano le principali fonti di gas serra. Infine, viene trattata e implementata la possibilità di ibridazione delle batterie agli ioni di litio con i supercondensatori, con un confronto rispetto all'ibridazione delle batterie allo stato solido con supercondensatori.

Parole chiave: Batterie agli ioni di litio (LIB), accumulo di energia, prestazioni delle batterie, sicurezza delle batterie, analisi del ciclo di vita (LCA), impronta di carbonio, batterie allo stato solido, sistemi di batterie ibride, veicoli elettrici (EV), accumulo di energia da fonti rinnovabili.

Contents

Abstract	iii
Abstract in italiano	iv
Contents	v
Introduction	8
1 Chemistry of batteries	9
1.1. Composition of batteries	9
1.2. Working principle of Lithium-ion battery.....	11
1.2.1. Discharge process (energy release).....	11
1.2.2. Charging process (energy storage).....	11
1.3. Solid electrolyte interphase (SEI)	12
2 Battery types and differences	13
2.1. Primary batteries	13
2.1.1. Alkaline batteries.....	13
2.1.2. Zinc-Carbon batteries	13
2.1.3. Lithium Primary batteries.....	14
2.2. Secondary batteries	14
2.2.1. Lead-acid (Pb-acid)	14
2.2.2. Lithium-ion (Li-ion)	14
2.2.3. Nickel-cadmium (Ni-Cd)	15
2.2.4. Nickel-metal hydride (Ni-MH)	15
2.2.5. Sodium-Sulfur (NaS)	16
2.2.6. Vanadium-redox flow battery (VRFB).....	16
2.3. Specialty batteries.....	21
2.3.1. Zinc-air batteries.....	21
2.3.2. Solid-state batteries	21
2.3.3. Thermal batteries.....	22
2.4. Conclusion.....	22
3 Lithium-ion batteries	23
3.1. Different types of Lithium batteries	23
3.2. Lithium-ion battery cell Format	24
3.3. Design approach of Lithium-ion battery	24

3.4.	Electrical performance of a Lithium-ion battery.....	25
3.5.	Temperature analysis.....	31
3.5.1.	Effect of low temperature.....	31
3.5.2.	Effect of high temperature	32
3.5.3.	Temperature for different types of lithium-ion batteries	33
3.6.	Safety of a Lithium-ion battery.....	34
3.7.	Reliability and quality control.....	35
3.8.	Cost of a lithium-ion battery.....	36
3.9.	Application of Lithium-ion battery	38
3.9.1.	Residential energy storage	38
3.9.2.	Electric Vehicles.....	39
3.9.3.	Grid scale Energy Storage	39
3.9.4.	Consumer Electronics	40
3.10.	Future of Lithium-ion battery.....	40
4	Carbon footprint of Lithium-ion Battery.....	41
4.1.	Life cycle of LIB	41
4.1.1.	Raw material acquisition.....	41
4.1.2.	Components manufacturing.....	41
4.1.3.	Battery assembly.....	41
4.1.4.	Transportation	41
4.1.5.	Use phase.....	42
4.1.6.	End-of-Life.....	42
4.2.	Lifecycle assessment (LCA)	42
4.2.1.	Models of LCA (system boundaries).....	43
4.2.2.	LCA impact categories.....	43
4.2.3.	Calculate the carbon footprint for each type of lithium-ion battery, using the LCA assessment	45
4.2.4.	Comparison between the sources and the MATLAB calculations... 48	
4.2.5.	Strategies to reduce carbon footprint	49
5	Lithium-Ion vs Solid-State Batteries	50
5.1.	Lithium-based Solid-State batteries.....	50
5.1.1.	Composition of a solid-state battery.....	50
5.1.2.	Electrical parameters of a solid-state battery	51
5.1.3.	Safety of a solid-state battery.....	52
5.1.4.	Cost of a solid-state battery.....	52
5.2.	Comparison between Solid-State and Lithium-ion batteries.....	53
5.2.1.	Electrical parameters comparison.....	53

5.2.2.	Safety comparison.....	53
5.2.3.	Cost comparison.....	53
6	Hybridization of batteries	55
6.1.	Hybrid configuration.....	55
6.1.1.	Lithium-ion batteries and supercapacitors.....	56
6.1.2.	Solid-state batteries and supercapacitors	57
6.1.3.	Comparison of the hybrid systems.....	58
6.2.	System topology and control.....	59
6.2.1.	Passive hybrid energy storage topology (P-HEST).....	59
6.2.2.	Active hybrid energy storage topology (A-HEST).....	60
6.2.3.	Discrete hybrid energy storage topology (D-HEST).....	60
6.3.	Implementation of a hybrid system	60
6.4.	Challenges and considerations.....	64
6.5.	Application of a hybrid system.....	64
	Bibliography	65
	Appendix A: Definitions.....	85
	Appendix B: MATLAB code	86
	List of Tables	89
	List of Figures	90
	Abbreviations	92
	List of symbols	94
	Acknowledgments.....	95

Introduction

The year 1800 marked the year of the invention of the true battery, by Alessandro Volta. Since then, a significant increase in the use of batteries has been observed[1].

Moreover, the battery market has experienced dynamic growth over the years and continues to expand, for example, the battery demand for electric vehicles and E-bus has increased from 31 GWh in 2015 to 321,113 GWh in 2021 [2].

This remarkable growth reflects the increased need of portable energy source[3], and the need of clean and sustainable source of energy[4].

According to [5], three main fields of battery usage exist. The first field is the stationary battery storage systems. This field represents batteries that are usually connected to electric grid, implemented in homes (such as PV), industrial storage (such as UPS systems), and utility storage (such as grid integrated battery storage) [5]. The second field is the mobile batteries that are used in electric vehicles such as commercial vehicles, rail transport and aviation [5]. Finally, the third field is portable batteries, used in applications such as smartphones, laptops, tables, and power tools [3], [5].

However, for each application, various kinds of batteries are needed. Each type of battery has its own unique characteristics and specific applications. While all battery types serve different purposes, some are more commonly used than others due to factors such as efficiency, cost, and demand in various industries. Therefore, the following review will discuss the types and show that difference between them. In additions, this review will further focus on the lithium-ion batteries, considering that they are the most commonly used for different reasons [6].

Moreover, this review will further discuss the different aspects of lithium-ion batteries, in terms of electrical parameters, temperature, safety, cost, and carbon footprint of the battery. In addition, analyzing and showing the hybridization of lithium-ion batteries. And comparing the lithium-ion batteries to the solid-state batteries, while showing the advantages and disadvantages of each.

1 Chemistry of batteries

The first chapter describes the chemical working principle of batteries. Including the composition of batteries, and the operating principle.

1.1. Composition of batteries

Batteries operate based on chemical reactions that transform the stored chemical energy into electrical energy. Every battery consists of Two Electrodes (anode and cathode) which are separated by Electrolytes and a separator.[7]

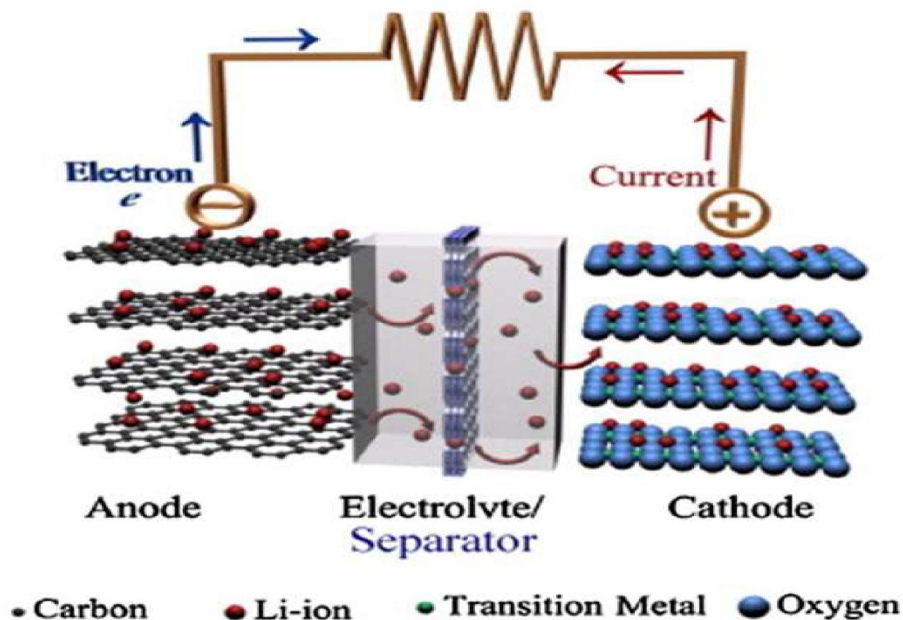

Figure 1: Li-ion battery diagram[7].

Considering the lithium-ion batteries then the above elements will be as follows (figure 1):

The anode is a negative electrode that consists of a graphite-based slurry layered onto the copper foil current collector. [7]

The cathode is a positive electrode composed of transition metal oxide such as LCO, LMO, NMC, NCA, LFP. Coated onto an aluminum foil current collector. [7]

Electrolyte: liquid electrolytes are used in lithium-ion batteries and are the main source of positive lithium ions of the battery. They are dissolved as lithium salts within the electrolyte, such as lithium hexafluorophosphate (LiPF₆). The movement of electrons between negative and positive current collectors is facilitated by their mitigation to and from the anode and cathode through the electrolytes [7].

During the charge and discharge process, the organic solvent in the electrolytes dissolve and transport the lithium-ions between the anode and cathode. So, they have extremely high ion conductivity. Solid (non-aqueous) electrolytes, such as polymers and ceramics, used in solid state batteries, are also used in some cases such as EVs, because they are less flammable than the liquid electrolytes [7].

Nevertheless, liquid electrolytes contain flammable organic solvents, which means, in case of battery overheating, this would lead to a thermal runaway resulting in a fire. In addition, liquid electrolytes are subject to formation of lithium dendrites. Which can lead to a short circuit of the cell and make the battery more at risk of explosion. This is why solid-state batteries are a solution that uses solid electrolytes eliminating all these safety risks. This issue will further be elaborated in the review [7].

Separator: it is a thin microporous polymer membrane, such as polypropylene and polyethylene, which facilitates the transport of the ions within the cell, also, it acts as an electrolytes reservoir and isolates any contact between the anode and the cathode. This will lead to a smooth exchange of Lithium ions while preventing the flow of electrons. Which means preventing any internal short circuit [7].

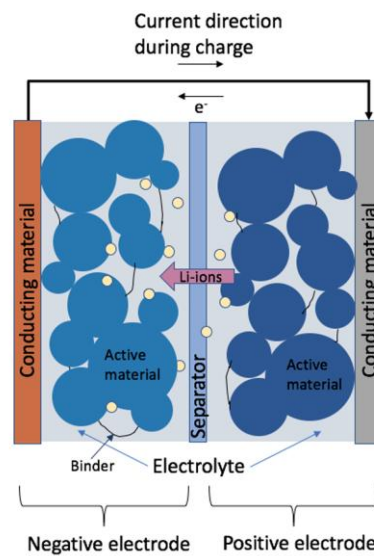

Figure 2: Binders in Li-ion battery [8].

Binders: as shown in figure 2, is a polymer that maintains the mechanical integrity and the electrochemical stability of the electrode. In addition, it contributes to the formation of a stable solid electrolyte interphase layer (SEI). Typically, the binders used in the anode application are water-based polymer, such as alginates (ALG) and polyacrylic acid (PAA). While the one used in cathode application is the polyvinylidene fluoride (PVDF) [7].

1.2. Working principle of Lithium-ion battery

The working principle of the Lithium-ion battery consists of the movement of the ions between the anode and the cathode [9], [10]. This results in two operations (figure 3):

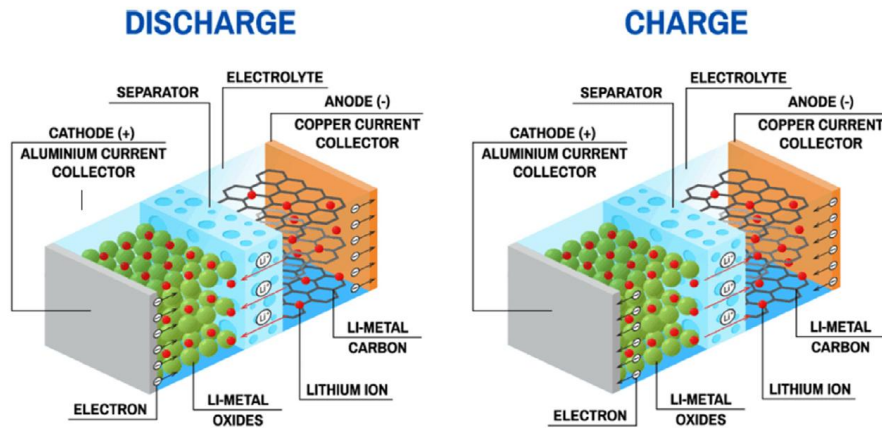

Figure 3: Charge/Discharge operations of Li-ion battery [9].

1.2.1. Discharge process (energy release)

Looking at the left side of figure 3, at the anode, when the battery is connected to a device, the material goes through oxidation, which means the lithium atoms lose the electrons and become lithium ion (Li^+) [9], [10]:



The electrons travel through the external circuit to the cathode, generating a current to power the device.

At the cathode, the Li^+ and the e^- that got to the cathode get electrically neutralized, and form a lithium metal and get stored in the cathode:



Overall cell reaction during discharging:



[9], [10]

1.2.2. Charging process (energy storage)

Looking at the right side of figure 4, at the anode, the lithium ions migrate back to the anode [9], [10]:



The electrons flow back to the anode due to the external power source.

At the cathode, the lithium ions leave and go back through the electrolytes to the anode:

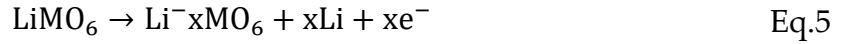

Overall cell reaction during charging:



Where M and C represents metal and carbon respectively [9], [10].

1.3. Solid electrolyte interphase (SEI)

Solid Electrolyte interphase (SEI) is a crucial component, a layer that forms in lithium-ion batteries, significantly influencing their performance and lifespan[7], [8], [11].

The SEI layer forms during the initial charge cycles of a LIB, due to the electrochemical reduction of electrolyte components at the anode surface[7], [8], [11].

So, the composition of the SEI is influenced from the electrolyte's composition, electrode materials and operating conditions (When a battery failure occurs due to temperature increase, the SEI on the anode active material surface is the first component to be affected) [7], [8], [11].

The SEI acts as a passivation layer on the anode surface. It allows the transport of lithium ions between the electrolyte and the electrode while blocking the flow of electrons, which prevents the decomposition of the electrolyte. In addition, a stable and well-formed SEI is essential for achieving good coulombic efficiency and preventing short circuit in the battery [7], [8], [11].

Even though the description of the working principle of the battery is made for the Lithium-ion battery, the principle is the same for all the different types of batteries except that it differs through the electrodes, the electrolytes materials used, and the recharging capabilities, since some types of batteries cannot be recharged.

2 Battery types and differences

This section presents a comprehensive analysis of three types of batteries: primary, secondary and specialty. It examines their characteristics, efficiency, and overall performance. Additionally, it will highlight the battery technology that demonstrates the highest performance and efficiency in the market, across various applications.

2.1. Primary batteries

Primary batteries are called 'consumer batteries' because they are used for domestic applications such as in watches, toys [12]. They are cells or groups of cells designed for single use, intended to be discarded once their stored electrical energy is exhausted[13]. They usually have a cylindrical shape, they are used as a single cell and are grouped in series when higher voltage is needed [12]. These batteries are assembled in a charged state, and their primary and only operation is to discharge only once, then they are removed and replaced by new batteries [13].

Currently, three distinct types of primary batteries are used: Alkaline, Zinc carbon and Lithium primary. The analysis will be conducted based on various aspects, such as composition, capacity, market and cost.

2.1.1. Alkaline batteries

Alkaline batteries composed of zinc anode, an electrolytic manganese dioxide cathode (Zn-MnO₂), and an alkaline electrolyte [14], [15]. These batteries dominated the single-use battery market for decades [15], [16], especially the market of portable electronic devices, because they have a typical nominal voltage of 1.5V [14], [16]. These batteries have a capacity and energy density 5 times higher than an equal sized battery with mild acid electrolyte [16]. In addition, they are used as well in low-power electronics, such as toys, radios and flashlights [14]. The materials used in the composition of the alkaline batteries contribute to its cost-effectiveness [14], [17].

2.1.2. Zinc-Carbon batteries

Zinc-carbon batteries, also known as Leclanché cells, are one of the oldest primary battery technologies [18]. They are composed of zinc anode, a manganese dioxide cathode and an electrolyte [19], [20]. Typically, they produce a nominal voltage of 1.5V, which makes them ideal for low-drain applications such as remote controls and clocks [18]. One of the advantages of the zinc carbon batteries is their low production cost and affordability [18], [21], [22], which makes them still existing despite their not so high performance comparing to the alkaline batteries, even though, the alkaline have

higher capacity and longer life than the zinc carbon [18]. And this led to a decrease in their market over the years [18].

2.1.3. Lithium Primary batteries

Lithium primary batteries are composed of lithium metal anode, a cathode material and a non-aqueous electrolyte [12]. The nominal voltage of the lithium primary ranges between 1.5V and 3.7V, with 3V being the most used [12], [23]. This allows them to have a longer-lasting power and therefore, be used in applications that needs it, such as medical devices like pacemakers, military equipment such as night vision equipment, and electronic devices such as computers and watches [12], [23], [24]. In addition, lithium primary batteries have a higher cost, compared to other primary batteries, because of the use of expensive materials in their composition [23].

2.2. Secondary batteries

Secondary batteries, also known as rechargeable batteries, are electrochemical energy storage technologies that can be recharged and used several times. In contrast to the primary batteries, secondary batteries can be charged and discharged multiple times and have usually a long lifespan [6].

Different kinds of secondary batteries will be analyzed based on cost, performance (energy and power characteristics), efficiency, lifespan, application, advantages, and disadvantages.

2.2.1. Lead-acid (Pb-acid)

Lead-acid battery is used in energy storage systems and has been used for a long time [6], [25]. These batteries have a nominal cell voltage from 2V to 2.1V[6], [25]. In addition, they have specific energy that ranges between 25 to 50 (Wh/Kg), and an energy density that ranges between 25 and 500 (kWh/m^3) [6], [26]. The efficiency of lead-acid batteries ranges between 63% and 90% [6], [26]. While they have a self-discharge rate from 0.1 to 0.3% per day and lifespan of 2 to 15 years, [6], [26], and it is suitable for stationary applications, such as uninterrupted power supply (UPS), and domestic energy storage (houses) [25], [27]. The advantages of the lead-acid battery are that it is of low cost and has high nominal cell voltage. Its disadvantage is its shorter lifespan when compared to other type of batteries, also, that they largely depend on temperature, while its working temperature is between 18 and 45°C [6], [27].

2.2.2. Lithium-ion (Li-ion)

Lithium-ion batteries are applied to grid-level energy storage systems that have been used since the 1990s [28]. Different kinds of Lithium-ion batteries exist. For example, Lithium Cobalt Oxide (LCO), Lithium Iron Phosphate (LFP), Lithium Nickel Manganese Cobalt Oxide (NMC), Lithium Nickel Cobalt Aluminum Oxide (NCA),

Lithium Manganese Oxide (LMO), and Lithium Titanate (LTO). These batteries have a nominal cell voltage range from 2.5V to 5V [6]. In addition, they have specific energy that ranges from 75 to 250 (Wh/Kg) and an energy density that ranges from 95 and 500 (kWh/m³) [6], [26]. The efficiency of lithium-ion batteries ranges between 75% and 95% [6], [26]. While they have a self-discharge rate from 0.1 to 0.3% per day and a lifespan between 5 and 15 years [6], [26], and it is suitable for large scale deployment applications, such as power hybrid and electrical vehicles [6], [28]. All the parameters mentioned vary based on the type of Lithium-ion battery used. In addition, it is suitable for light weight applications due to its high specific energy and power [26]. The advantages of Lithium-ion batteries are the long lifespan, in addition to high specific energy and power. While its disadvantage including high cost and poor performance at elevated temperatures, which can lead to failure, as their optimal operating range is between 20°C and 65°C [6], [28]. All information mentioned will be further elaborated in the next chapter.

2.2.3. Nickel-cadmium (Ni-Cd)

Nickel-cadmium batteries are an energy storage technology that has been used for a long time [6]. These batteries have a nominal cell voltage ranging from 1.2V to 1.3V [6], [28]. In addition, they have a specific energy that ranges between 30 and 80 (Wh/Kg), and an energy density that ranges between 15 and 150 (kWh/m³) [6], [28]. The efficiency of nickel-cadmium batteries ranges between 60% and 90% [6], [28]. While they have a self-discharge rate from 0.2 to 0.6% per day, they present a lifespan of 10 to 20 years [6], [28]. It is suitable for applications where long battery life and critical environmental conditions are required, such as emergency power supply of rail transit trains, mining vehicles and heavy-duty vehicles [29]. The advantages of the Nickel-cadmium battery are that they have low maintenance cost, and ability to resist electrical and physical stress. While its disadvantages are high cost, limited energy density and high temperature has a little effect on its performance, because its working temperature is between -40 and 50°C [6], [30].

2.2.4. Nickel-metal hydride (Ni-MH)

Nickel-metal hydride batteries are an energy storage technology that is famous among the transportation sector [26]. These batteries have a nominal cell voltage from 1.2V to 1.35V [6]. Also, they have a specific energy that ranges between 40 and 110 (Wh/Kg), and an energy density that ranges between 40 and 300 (kWh/m³) [6], [26]. The efficiency of Nickel-metal hydride batteries ranges between 50% and 80% [6], [26]. While they have a self-discharge rate from 5 to 20% per day, they present a lifespan of 2 to 15 years [6], [26], it is suitable for electric and hybrid-electric vehicles because of its high specific energy and power [31], [32]. The advantages of the Nickel-metal hydride battery is long lifetime and good performance and high temperature. While

its disadvantage is high cost and trouble of performance at low temperature, it operates between -30 and 70°C [6].

2.2.5. Sodium-Sulfur (NaS)

Sodium-sulfur battery is suitable for energy storage systems usage due to its high energy density [6], [33]. These batteries have a nominal cell voltage from 1.8V to 2.71V [6]. In addition, they have specific energy that ranges between 150 and 240 (Wh/Kg) and an energy density that ranges between 150 and 350 (kWh/m³) [6], [26]. The efficiency of sodium-sulfur batteries ranges from 75% to 90% [6], [26]. While they have a self-discharge rate of 0% per day, they present a lifespan of 10 to 15 years [6], [26]. It is suitable for high energy density demanding applications, such as emergency power and load levelling, electric transmission and distribution system support [26], [34]. The advantages of the Sodium-sulfur battery are, its capability of pulse power (the ability to give short bursts of high-power output) and good resistivity to self-discharge [6], [34]. While its disadvantages are high cost and the need for high temperature for the functioning of the battery (operating at 300-350°C) [6], [35].

2.2.6. Vanadium-redox flow battery (VRFB)

Vanadium-redox flow batteries are a new technology of energy storage devices that is being used [6]. These batteries have a nominal cell voltage from 1.2V to 1.4V [6], [36]. Also, they have a specific energy that ranges between 10 and 130 (Wh/Kg) and an energy density that ranges between 10 and 33 (kWh/m³) [6], [26]. The efficiency of VRFB batteries ranges between 65% and 85% [6], [26] [37]. While they have a self-discharge rate of 0% per day, they present a lifespan of 5 to 15 years [6]. It is only suitable for stationary applications because it is limited by its low energy density [37]. The advantages of the Vanadium-redox flow battery are high operating safety and low maintenance cost. While its disadvantage in addition to the low energy density is the large space that need to be reserved for the placement of the VRFB, and its working temperature is between 5 and 45°C [6].

Table 1: comparison of secondary batteries.

Battery types	Nominal cell Voltage¹ (V)	Specific energy¹ (Wh/Kg)	Energy density¹ (Wh/L)	Lifespan¹ (Years)	Efficiency¹ (%)	Self-discharge rate¹ (% per day)	Working Temperature¹ (°C)	Reference dates
Lead-acid	2-2.1	25-50	25-90	2 to 15	63-90	0.1-0.3	18 to 45	2021,2022, 2023
Lithium-ion	2.5-5	75-250	200-750	5 to 15	75-90	0.1-0.3	20 to 65	2021, 2022
Nickel-cadmium	1.2-1.3	30-80	15-150	10 to 20	60-90	0.2-0.6	-40 to 50	2020,2021
Nickel-metal hydride	1.2-1.35	40-110	40-300	2 to 15	50-80	5-20	-30 to 70	2021,2022
Sodium-Sulfur	1.8-2.71	150-240	150-350	10 to 15	75-90	0	300 to 350	2021, 2022
Vanadium redox flow	1.2-1.4	10-130	10-33	5 to 15	65-85	0	5 to 45	2021, 2022

¹ Definition in Appendix A

Based on table 1, Lithium-ion batteries have the highest performance in terms of energy density. In addition, it has the highest nominal voltage (up to 5V). While all batteries have a performance problem either at high temperature or at low temperature, for example lead-acid and lithium-ion cannot tolerate temperatures lower than 18-20 °C, and higher than 45-65°C.

An analysis of every parameter will be conducted based on the average values taken from table 1.

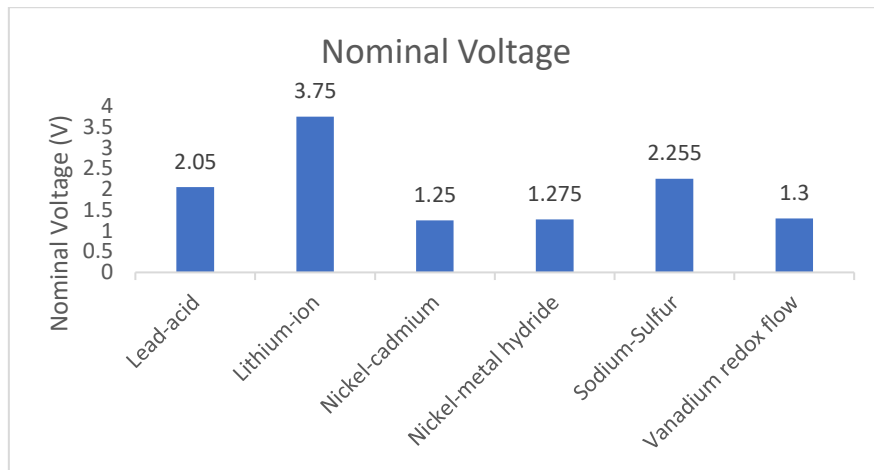

Figure 4: Nominal voltage of different types of batteries.

Based on the chart in figure 4, all the batteries have almost similar nominal voltages. While lithium-ion batteries have the highest nominal voltage, and the nickel-cadmium batteries have the lowest nominal voltage.

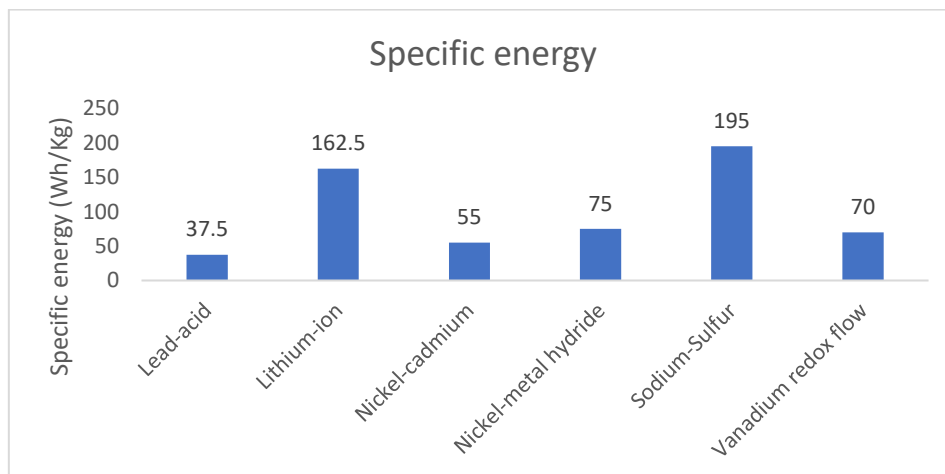

Figure 5: Specific energy of different types of batteries.

Based on the chart in figure 5, sodium sulfur and lithium-ion batteries have significantly higher specific energy than the rest of the batteries. While lead-acid batteries have the lowest specific energy out of all the batteries.

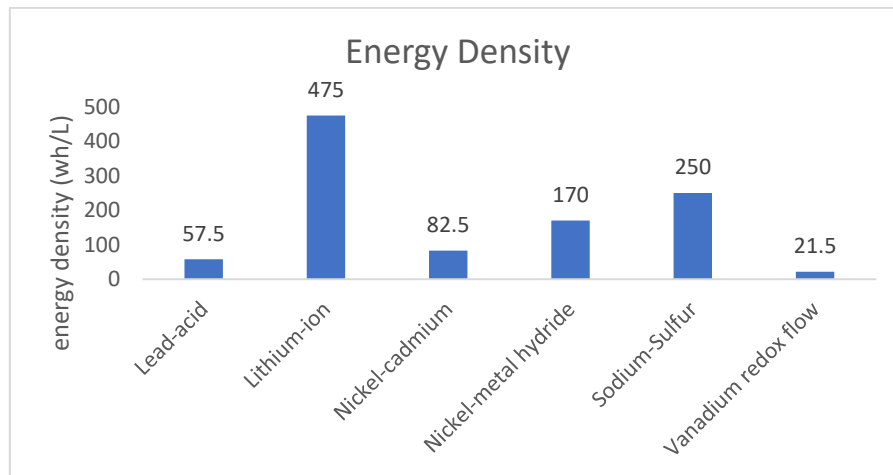

Figure 6: Energy density of different types of batteries.

Based on the chart in figure 6, out of all the types of batteries, lithium-ion batteries have the highest energy density, which makes it suitable for different kinds of applications. While vanadium redox flow batteries have the lowest energy density, which makes it only suitable for applications that require low energy density.

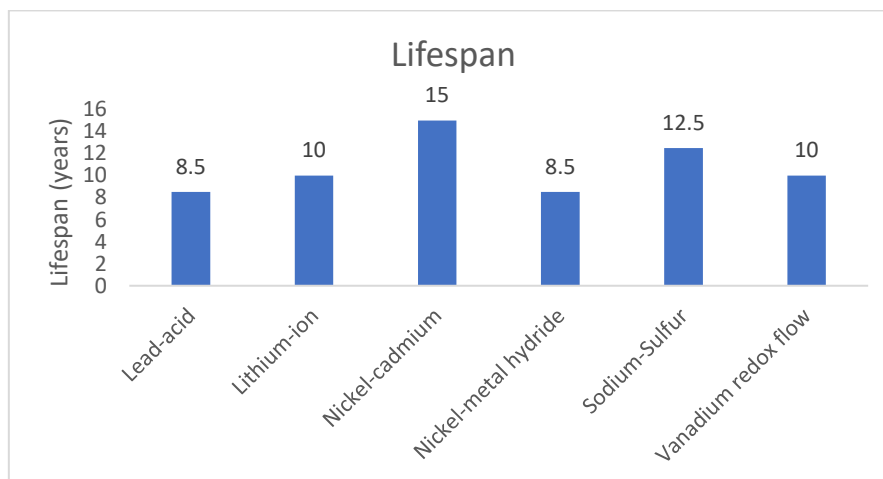

Figure 7: Lifespan of different types of batteries.

Based on the chart in figure 7, the average lifespan of a battery ranges between 8.5 to 15 years. Which nickel-cadmium has the highest lifespan and lead-acid, and nickel-metal hydride have the lowest lifespan.

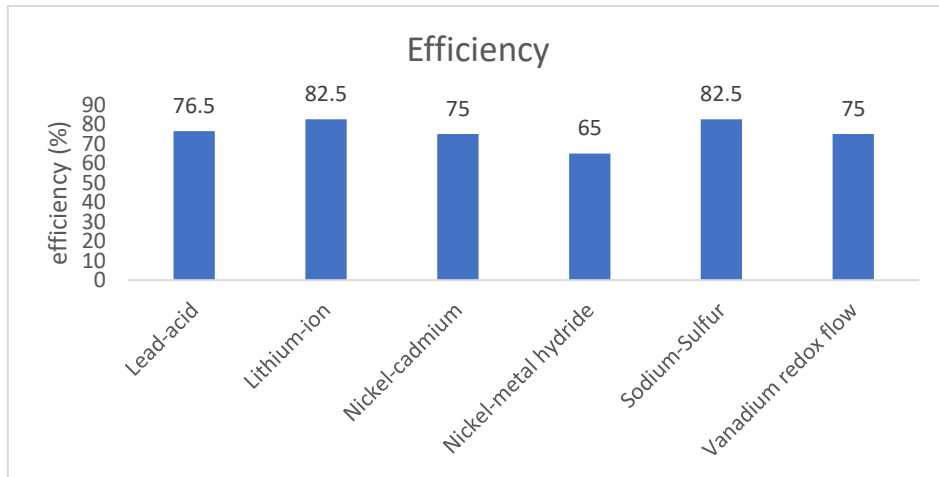

Figure 8: Efficiency of different types of batteries.

Based on the chart in figure 8, the average efficiencies for all the batteries range between 65% and 82.5%, with lithium-ion and sodium-sulfur batteries being the highest and nickel-metal hydride being the lowest.

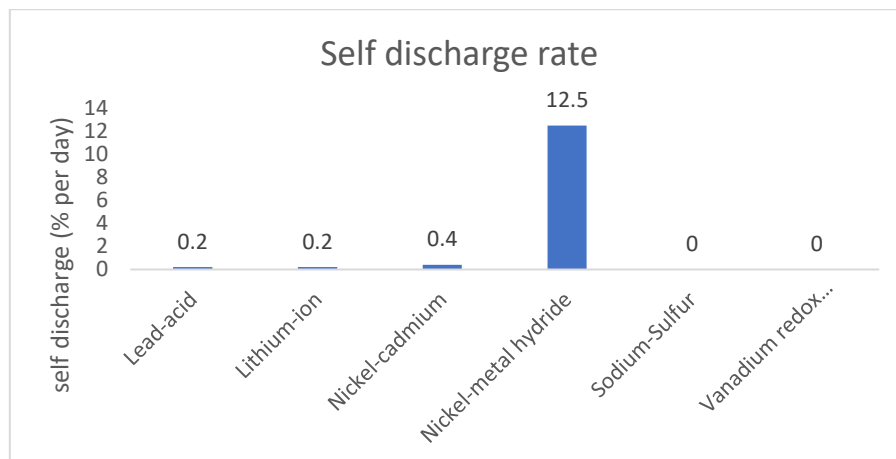

Figure 9: Self-discharge rate of different types of batteries.

Based on the chart in figure 9, the self-discharge rate for all the batteries is almost zero, except for the nickel-metal hydride batteries, due to its chemical composition and its usage for aqueous electrolytes which makes the ions move even at rest.

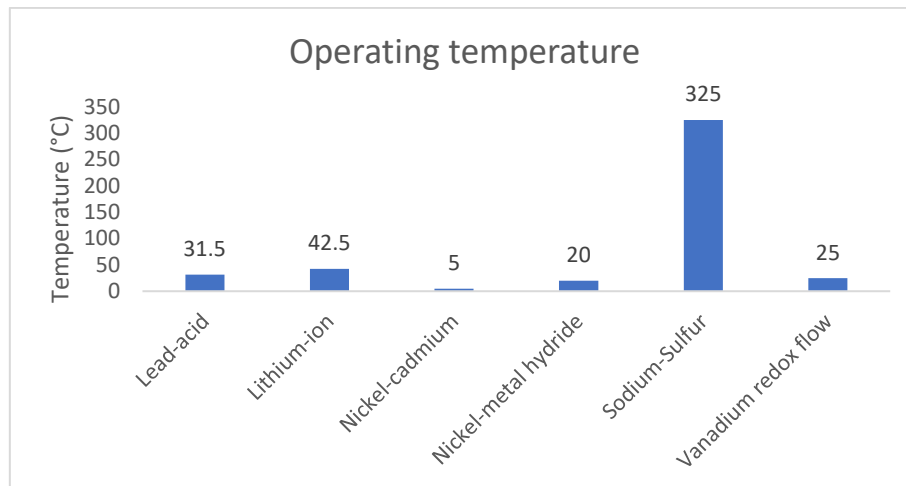

Figure 10: Operating temperature of different types of batteries.

Based on the chart in figure 10, every type of battery is used based on the application applied. For instance, if a very high temperature of 325°C is needed, then sodium-sulfur batteries are used. Otherwise, all other batteries have ranges that are close to each other.

2.3. Specialty batteries

Specialty batteries are primary and secondary batteries, used to fulfil the specific requirements of an application that the standard batteries are not able to meet, due to specific requirements for this application. This section will present some of the specialty battery types based on different aspects, such as energy density, safety, applications, environmental [38].

2.3.1. Zinc-air batteries

Zinc-air batteries, composed of Zinc (Zn) and oxygen, are a safe and environmental-friendly option of batteries [39]. These batteries are neither toxic nor non-flammable rechargeable batteries. [38]. Even though they have high energy density, they present with low power output capability due to the inefficiency of air catalysts available [39], [40]. Currently these batteries are used in medical and telecommunication applications [40]. In addition, Zinc-air batteries are being considered for use in Electrical Vehicles which require their low weight and volume, hence a higher energy density [38].

2.3.2. Solid-state batteries

Solid state batteries can be lithium and non-lithium based, they differ from the conventional liquid electrolyte batteries by having solid electrolytes [41], [42], [43]. This makes them less hazardous and less flammable, which offer higher safety than standard batteries, in addition to higher energy density [42], [43]. These batteries are used in low power requirements such as cardiac pacemakers [42]. Even though solid

batteries are suitable for high temperature, they cannot be used in low and ambient temperatures [42]. Another disadvantage of such batteries is that their production is challenging, since it requires high-quality manufacture cells at costs similar to the standard batteries, which means high automated scalable production processes [43].

2.3.3. Thermal batteries

Thermal batteries are primary batteries used in thermal and energy applications. In addition to military applications, such as missiles, shortening of the activation time is required for rapid launch, due to their high power and high reliability [44], [45]. This type of batteries is heat dependent, the ideal temperature range for a thermal battery is 500-550°C [45]. The crucial aspect for thermal batteries is that for each application, a new design for the batteries is needed, based on the operating time, current and voltage, and activation time needed for this specific application [45].

2.4. Conclusion

The next section will hold a detailed discussion about Lithium-ion secondary batteries. The discussion held in each of the above sections shows that first, the primary and specialty batteries cannot be compared to the secondary batteries because the first are single-use batteries and the second are batteries tailored for specific applications and are different from the standard batteries in the market. Hence after analyzing the different types of secondary battery and based on the comparison in table 1, Lithium-ion batteries have the best performance in specific energy and energy density terms.

3 Lithium-ion batteries

After comparing different types of batteries, this section will provide an in-depth analysis of lithium-ion batteries (LIBs). It will cover different types of LIBs, their structure and design, electrical characteristics, challenges, and issues that they face, fields of use, and their future.

3.1. Different types of Lithium batteries

Lithium-ion batteries are composed of Lithium ions Li^+ , which move from the anode to the cathode through electrolytes, or vis versa, during the charge/discharge process. Electrons flow, from the anode, through the external circuit, since the electrolytes allow only the flow of the lithium, to the cathode to power the device during discharge, or to store energy in charging phase. The cathodic materials used to help the electrons flow by reduction reaction involving a transition metal oxide are: Co^{4+} to Co^{3+} , Fe^{3+} to Fe^{2+} , Ni^{4+} to Ni^{3+} , Mn^{4+} to Mn^{3+} . The different cathodic materials used lead to different types of lithium-ion batteries [46].

All the above materials are used as cathodic material because they have high redox potentials compared to the Lithium Li^+ . Only graphite, Ti^{4+} to Ti^{3+} , is used as anode, due to its low redox potentials [46].

Therefore, the types of lithium batteries are: Lithium Cobalt Oxide (LCO) of empirical formula $LiCoO_2$, Lithium Iron Phosphate (LFP) of empirical formula $LiFePO_4$, Lithium Nickel Manganese Cobalt Oxide (NMC) of empirical formula $LiNiMnCoO_2$, Lithium Nickel Cobalt Aluminum Oxide (NCA) of empirical formula $LiNiCoAlO_2$, Lithium Manganese Oxide (LMO) of empirical formula $LiMn_2O_4$, and Lithium Titanate (LTO) of empirical formula $Li_4Ti_5O_{12}$.

All the mentioned types of LIBs fall into different crystal structures, which define how particles are arranged in three dimensions. In LIBs, the crystal structure of electrode material helps to determine its electrochemical performance:

The first structure is the **Olivine crystal structure** or polyanion oxides. The Lithium iron phosphate (LFP) falls into this structure, where the oxygen forms a hexagonal lattice close-packed lattice [47]. This structure's impact on the battery is stability, which leads to high cycle life and safety [48].

The second structure is the **layered oxides** which consist of layers of metal oxide compounds. The lithium cobalt oxide (LCO), the nickel cobalt aluminum (NCA), and the nickel manganese cobalt (NMC), all fall into that category [47], [49]. This structure results in high energy density for the battery, but a limited cycle life and thermal risks at high voltage. This affects some battery types more than others [47], [49].

The third structure is the **spinel oxides**, the lithium manganese oxide (LMO) and the lithium titanate (LTO), fall into that category. By replacing the manganese (Mn) by nickel (Ni), the structure gets called ordered spinel, otherwise, it is called disordered spinel [47]. This structure gives fast charge/discharge capability for the battery [50], [51].

3.2. Lithium-ion battery cell Format

The unit cell is the smallest repeating unit that defines the whole crystal structure. Three different cell types for lithium-ion batteries exist:

Pouch cell: it is made with soft special composite aluminum foil [52], or with a deformable cell housing made of aluminum foil [53]. It is characterized by its flexible outer housing [52]. Inside, the electrode layers, anode, cathode and separator, are stacked [52], [53]. The battery terminals are thin and made from metal [53]. This cell format guarantees high energy density and good space utilization [52]. Example of LIBs having Pouch cell are LCO, LMO, LFP, LTO.

Prismatic cell: it is made of metal and has a rectangular shape [52]. It is characterized by a rigid and stiff outer casing [52], [53]. Inside, the anode, cathode and separator are arranged by wrapping the individual bands around a core [53]. The battery pores are in the upper flat side at the outer edges [53]. Example of LIBs having Prismatic cell are LMO, NMC, NCA, LTO.

Cylindrical cell: it is made of metal and has a cylindrical form [52]. Similar to the prismatic cell, it is characterized by a rigid and stiff outer casing [52], [53]. Inside, the anode, cathode and the separator are arranged by winding around a core [53]. The battery terminals are arranged opposite to each other [53]. Examples of LIBs having cylindrical cells are LCO, LMO, LFP, NMC, NCA, LTO.

3.3. Design approach of Lithium-ion battery

The design process of lithium-ion batteries has evolved through the years, thanks to new technologies such as simulations, modelling, and machine learning. The process includes many steps. The design process begins with battery cell modelling, covering the electrochemical, electrical, and thermal aspects. The second step, and most important one, is the battery pack layout [54]. Some factors need to be taken into consideration such as cost, heat dissipation, manufacturing, and using approaches such as Cell-To-Pack and Cell-To-Chassis, which optimize the manufacturing process. The third step involves thermal management; therefore, systems such as air cooling and liquid cooling are added to the design. In addition, Model-Based Design is used to simulate complex system interactions and machine learning. It is important to improve the design through data analysis and prediction. Finally, studying how the

battery pack reacts under different stress conditions, to ensure safety and durability [54].

3.4. Electrical performance of a Lithium-ion battery

In this section, an analysis of the different aspects of each type of lithium-ion batteries will be done based on different Electrochemical compositions, such as charge voltage, capacity and power, charge/discharge rates, cycle life, efficiency. Electrochemical parameters are important because they usually affect the battery capacity, charging speed and cycle life, and safety. In addition, parameters such as temperature, safety, reliability, and cost will be analyzed as well in the upcoming sections.

Table 2: Parameters for the different types of LIBs.

Parameter Types	Charge voltage (V)	Capacity (Ah, per cell)	Energy density (Wh/L)	Specific energy (Wh/kg)	Specific power (W/Kg)	Charge/discharge rate* (C-rate)	Cycle Life* (cycles)	Efficiency (%)	References	Reference dates
Lithium Cobalt Oxide (LCO)	3.0-4.6	2-3	550-660	150-200	500- 2000	$\leq 1C$ (Moderate)	500- 1000	90%	[54], [55], [56],[58]	2022, 2023, 2024, 2025
Lithium Iron Phosphate (LFP)	3.2-3.6	2.5-3.5	325-400	90-120	200- 1000	$\geq 10C$ (high)	2000- 3000	90%	[55], [59], [60],[58]	2021, 2022, 2024, 2025
Lithium Nickel Mangan e Cobalt Oxide (NMC)	3.0-4.2	2.5-4.5	500-700	150-220	500- 2500	$\leq 5C$ (Moderate to high)	1000- 2000	90%	[55], [60], [61],[58]	2018, 2022, 2024, 2025
Lithium Nickel Cobalt	3.0-4.2	3.5-5.0	600-750	200-260		$\leq 1C$ (Moderate)	2000	90%	[55], [57], [58]	2021, 2022, 2025

Aluminium Oxide (NCA)					1000-3000					
Lithium Manganese Oxide (LMO)	3.0-4.2	1.5-2.5	350-400	100-150	925	$\geq 10C$ (high)	300-700	90%	[55], [57],[62]	2021, 2022, 2025
Lithium Titanate (LTO)	1.8-2.85	1.5-2.5	200-300	50-80	2200-3600	$\geq 10C$ (high)	3000-7000	95%	[55], [59], [61][1], [3], [4],[62]	2018, 2021, 2022, 2025

Table 2 represents a full analysis of the different types of lithium-ion batteries, based on their electrical characteristics and performance. They all have high efficiency, and the maximum voltage per cell that can be reached is 4.2V.

All lithium-ion batteries are rechargeable because they fall into the secondary batteries type, which are batteries that can be charged and discharged multiple times. Therefore, they all have a charge and discharge rate which is high for most of the types.

An analysis of every parameter will be held based on the average values taken from table 2.

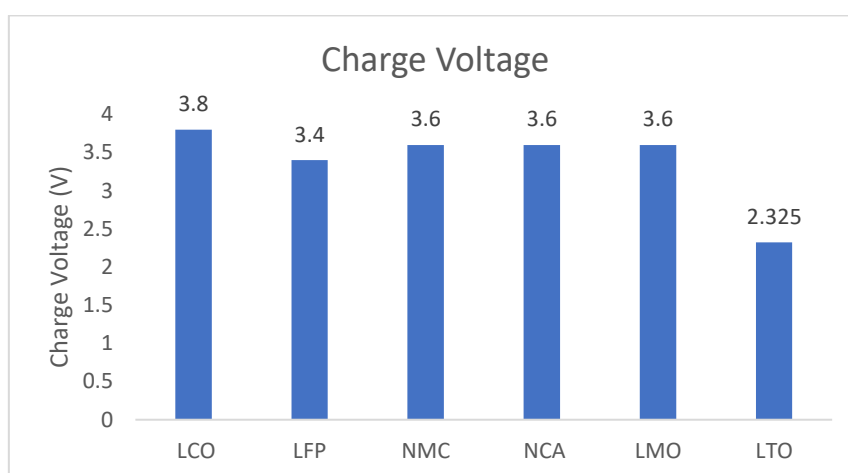

Figure 11: Charge voltage of different types of LIBs.

Based on the chart in figure 11, all types of lithium-ion batteries have almost similar charge voltages. While the LCO has the highest value and the LTO has the lowest value.

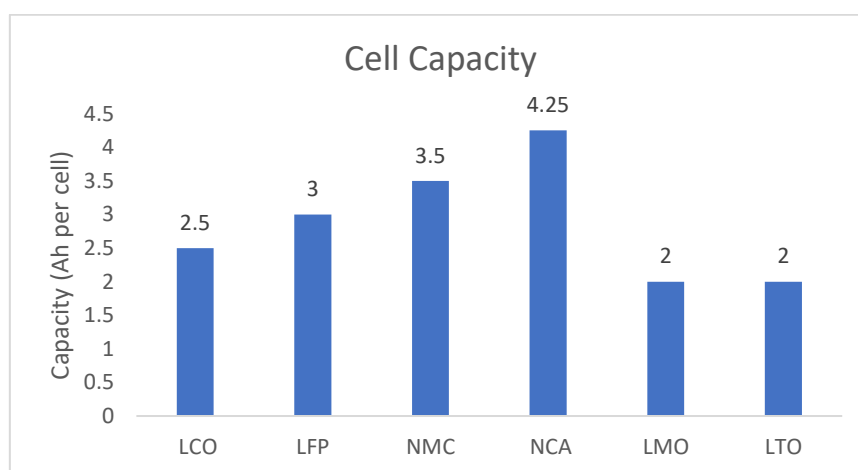

Figure 12: Cell capacity of different types of LIBs.

Based on the chart in figure 12, all types of LIBs have close values for the cell capacity. The highest value is the one of the NCA, while the lowest is the one of LTO and LMO.

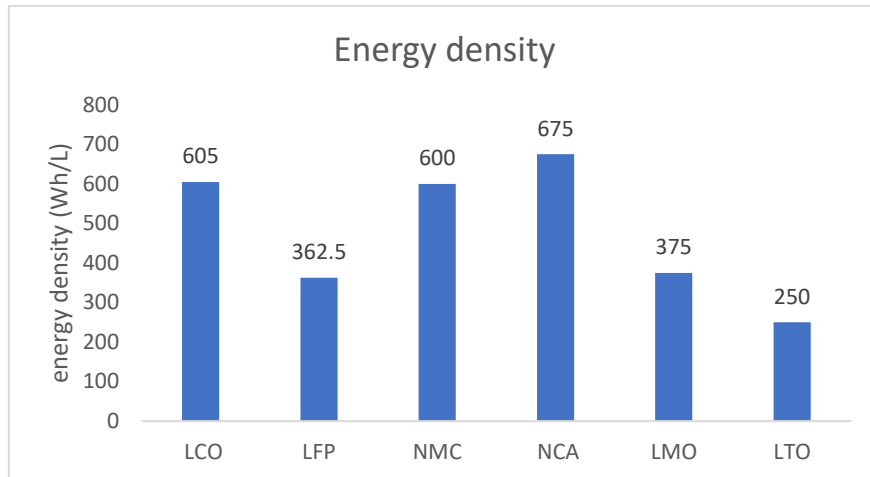

Figure 13: Energy density of different types of LIBs.

Based on the chart in figure 13, among the types of LIBs, NCA holds the highest energy density, which makes it useful in applications that require high energy density. While LTO holds the lowest energy density, which makes it useful only for low energy applications.

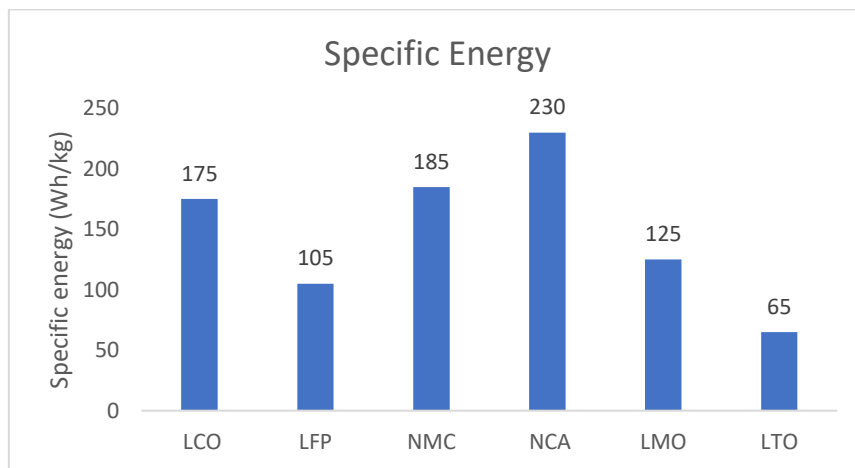

Figure 14: Specific energy of different types of LIBs.

Based on the chart in figure 14, the same situation as it was for energy density is applicable here. Having NCA with the highest specific energy and LTO with the lowest specific energy.

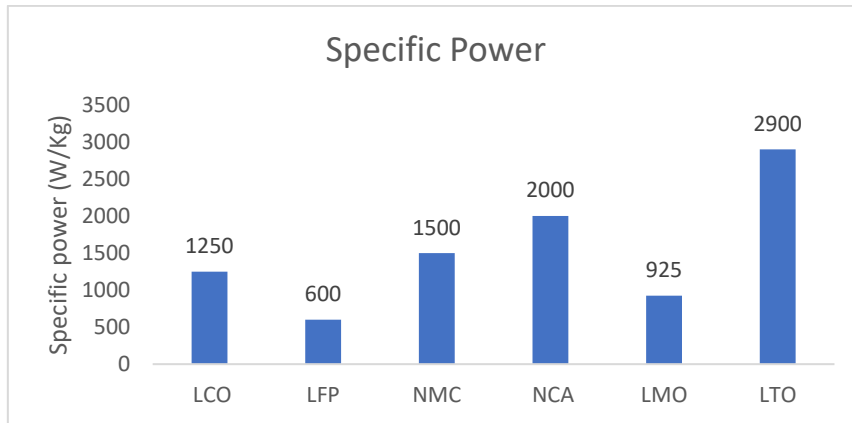

Figure 15: Specific power of different types of LIBs.

Based on the chart in figure 15, when in need of a very high specific power, LTO is the lithium-ion battery that should be used. While if a low specific power is needed, then LFP can be used, since it has the lowest value.

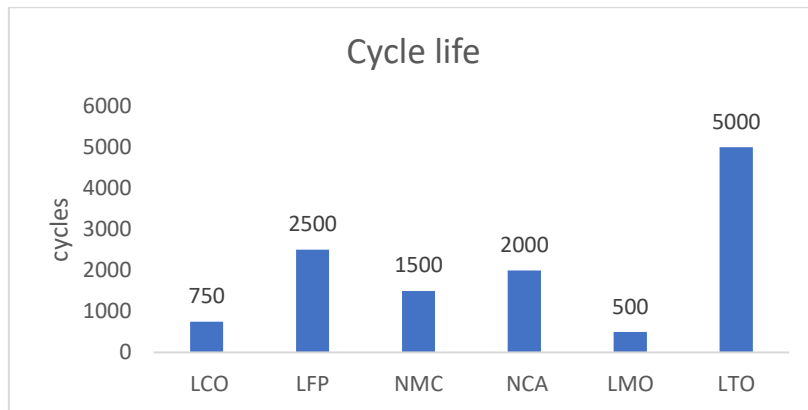

Figure 16: Cycle life of different types of LIBs.

Based on the chart in figure 16, even though LTO has the lowest specific energy and energy density, it has the highest cycle life out of all kinds of LIBs.

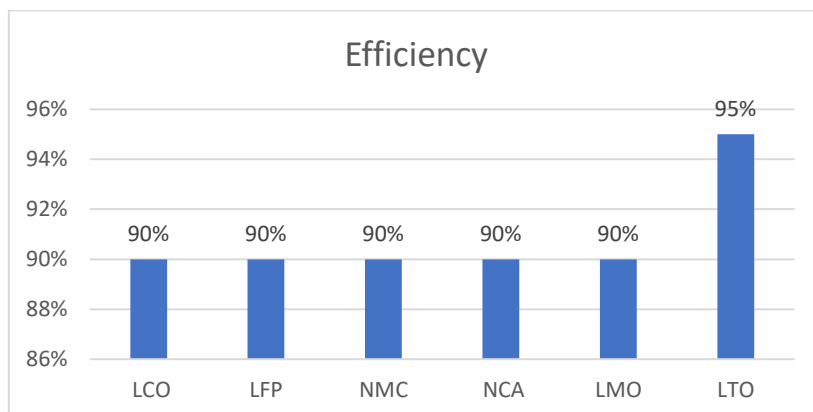

Figure 17: Efficiency of different types of LIBs.

Based on the chart in figure 17, all types of LIBs have the same percentage of efficiency of 90%, while LTO have a higher efficiency of 95%.

In conclusion, each type of LIB has its own specifications, which will be useful in a specific type of application.

3.5. Temperature analysis

Temperature is a critical parameter that limits the field of use and applications of LIBs. Low temperature or high temperature have a major impact on the performance of the batteries in different ways. According to [63] low and high temperatures are considered outside -20°C to 60°C range. While according to [64], the optimal working temperature range is between 15°C and 35°C .

The following sections will discuss the effects of low and high temperatures.

3.5.1. Effect of low temperature

The effect of low temperature, below 0°C , is mostly seen in countries with very low temperatures such as Russia and Canada.

At low temperatures, the performance parameters, such as capacity, power and cycle life worsen rapidly [65], [66]. For example, a study done by Nagasubramanian, showed that the power and energy densities of a LIB were 800W/L and 100Wh/L respectively at 25°C , but these values drastically decreased to 10W/L and 5Wh/L at -40°C [67]. This happens because, at low temperatures, the viscosity of the electrolyte increases, which reduces the ionic conductivity. Consequently, internal resistance increases, thus reducing the performance of the battery [67].

Another effect led to the deterioration of the performance of the battery is the increase of charge-transfer resistance* (the movement of electrons and ions) of the battery [66]. Taking the Lithium Iron Phosphate (LFP) of composition LiFePO_4 as an example, after testing, the charge-transfer resistance was seen to be three times higher at low temperatures (-20°C) [68]. Therefore, the charge-transfer resistance increased with the decrease in temperature, which implies an inversely proportional relationship between the charge-transfer resistance and the temperature [69]. This increase affected the performance of the LIB by affecting the kinetics of the battery. Which means, it influences the rate of electrochemical reactions* inside the battery [66].

Lastly, lithium plating is another effect of low temperature. Due to the cold, the anode becomes polarized, and its voltage will get closer to the lithium voltage. This will slow down the charging process leading to the reduction of the battery performance [65], [66]. In addition, the lithium plating can grow and cause short circuits inside the battery [65], [66].

For example, the use of LIBs in electric vehicles and hybrid electric vehicles in low temperature environments, the effects mentioned above will lead to lower power capabilities and might cause performance failures [66].

As a solution, thermal management systems have been added to heat the batteries and restore their performance. Nevertheless, these thermal management systems influenced the size and weight of the vehicles and caused uneven temperature distribution in the battery pack [65].

Another solution is to use electrolytes in an extended operating temperature range [66]. This method was tested by [70] and proved to be effective. In addition to adding electrolytes additives improved the performance of LIBs [66], [71].

3.5.2. Effect of high temperature

The effect of high temperature on the lithium-ion batteries is much more crucial than the effect of low temperature. Three main effects of high temperature are presented.

First, heat generation. During the work of LIB, heat is generated inside the battery due to charge transfer and the charge/discharge process. The heat generation is classified into two types: the reversible and irreversible process. The reversible process, known as entropic heat, comes from the disordered change in electrochemical reactions [66], [72]. The irreversible process originates from different causes, such as the ohmic heating process caused by resistance of electrode and electrolytes. Heating occurs due to the mixing caused by the uneven distribution of ions during charge and discharge process, along with enthalpy changes caused by phase transitions in the cathodes [66], [72].

Second, the battery ages during high temperature. Aging affects the performance of the LIB and reduces the lifetime of the LIB. Because of the high temperature, the aging process is accelerated and caused degradation of the battery [66]. A study done by Gao et al. 2023 [68], where LIB cells were tested at different temperature: cells aged at 25°C and 40°C shows slow capacity decay, while cells aged at 60°C show that the rate of capacity decay increases gradually after the first 30 cycles, when the solid electrolyte interphase (SEI) layer can no longer protect the anode from interacting with the electrolytes [68].

Finally, when the lithium-ion batteries are either mishandled during manufacturing, or defective, a thermal runaway behavior may arise at high temperatures. This behavior will lead to exothermic reactions within the battery, meaning that during the charge and discharge process, the battery will release energy in the form of heat and an increase in the temperature will occur to more than 800°C [66], [72], [73]. Which will lead to deterioration stages: starting with capacity loss, followed by decomposition of the SEI layer, reaction between the anode and electrolyte, melting of the separator, internal short circuit, decomposition of the anode, and eventually the breakdown of the cathode, electrolytes, and binders. This will eventually increase the risk of explosion of the battery [66], [72], [73].

For example, a thermal runaway could happen in an electric car, if that car got into an accident, the heat would dissipate, and reactions that will occur then will trigger a thermal runaway, leading to flames, and maybe causing an explosion [71].

This is why it is important to have a thermal management system which has a job to ensure that the battery is inside the range of temperature that will not cause a malfunctioning or deterioration in the performance [71].

3.5.3. Temperature for different types of lithium-ion batteries

The following graph explains the tolerance of each type of LIB to the increase of temperature [10].

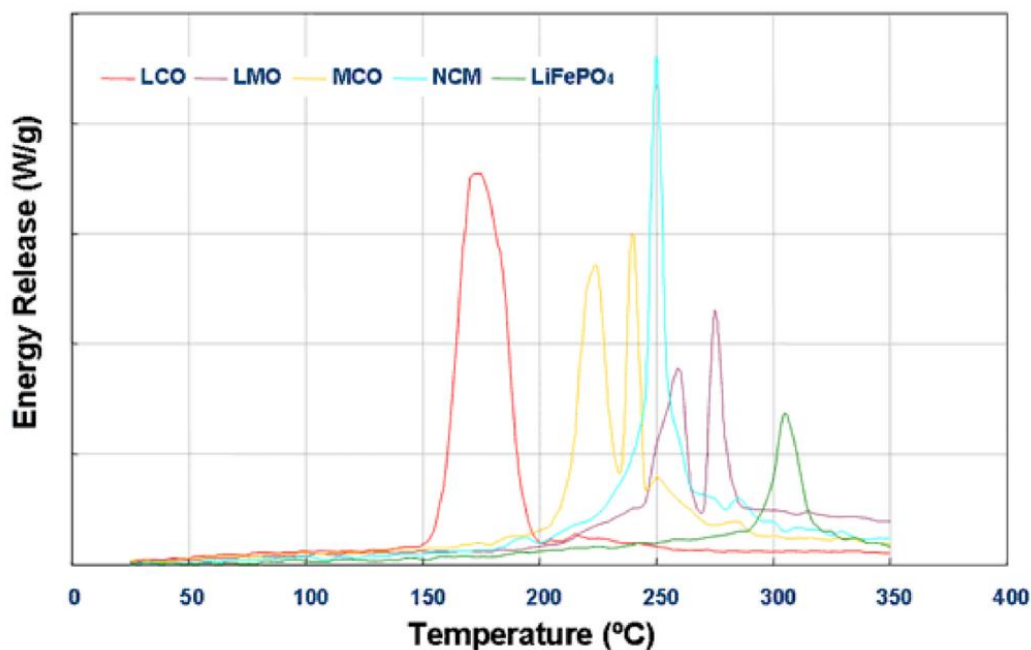

Figure 18: Comparison in peak energy release for different types of LIBs [10].

In figure 18, each peak represents the maximum energy released at a specific temperature, by each battery type. Energy release means that when the lithium-ion battery cathode material is heated, they decompose, react with the electrolyte and release oxygen. All these exogenic reactions will release energy in the form of heat [10].

Based on the figure, LCO has its peak energy release at 170°C. LMO has its peak energy release at 240°C. NCA has its peak energy release at 230°C. NCM has its peak energy release at 250°C. LFP has its peak energy release at 310°C [10].

Based on this analysis, the LCO battery, exposed to the highest safety risk and has low thermal stability. While LFP and LTO are the safest when it comes to operating in high temperatures [10].

3.6. Safety of a Lithium-ion battery

In November 2023, a Renault Zoe battery exploded due to possible overcharging [10].

In October 2023, a truckload of Tesla Model Ys caught fire in turkey due to battery crushing during transportation [10].

In July 2018, an energy storage system caught fire in Korea due to a fire igniting in one LIB, spreading to more than 3500 batteries [10].

In January 2013-2014, three Boeing 747 caught fire, due to short circuit and battery management system failure [10].

In March 2010, two iPod nanos caught fire by heating up in Japan, due to overheating of the Li-ion batteries [10].

All these cases and many more are happening because of failures of the LIBs, which raise three different safety issues in Lithium-ion batteries:

One of the main reasons for safety issues and risks is thermal abuse. For example, the short circuit caused by lithium plating which happens at low temperature as explain in section 3.5.1, in addition to the thermal runaway due to high temperature, which will lead to the explosion of the battery as explained in section 3.5.2. These situations occur when the battery experience thermal shock [74], especially at high temperature. Which leads to it catching fire. And comparing different types of lithium-ion batteries, as mentioned in section 3.5.3, LFP batteries are the safest, while exposed to high temperatures [74].

A second reason is electrical abuse, for example, overcharging an electric scooter, or an e-bike overnight will lead to thermal runaway and fire. In addition, an electrical abuse includes, over-discharging, and external short-circuits [71], [75]. In addition, overcharge is described as the most dangerous type of electrical abuse and the most frequent reason for LIB safety accidents [74]. Because during overcharging, extra energy is stored, leading to the increase of temperature, which makes the cathodic material unstable, and it starts to release heat, leading to overheating and rupture. An external short circuit, on the other hand, occurs when the cathode and anode are in direct contact through a conductor, causing a rapid discharge and a rapid heat release [74].

A third reason is mechanical abuse caused by collision or crash (in the case of EVs), and accidents, and nail penetration, meaning that because of the accident, components from the electric vehicle may penetrate the battery module if it was poorly designed [71], [75]. Even the deformation of the case of the battery can damage the internal components, causing internal short circuits due to direct contact of the electrodes [74].

Thus, in electric vehicles, as well as any other application that include lithium-ion batteries, Battery management systems (BMS) is important and crucial for monitoring,

thermal management, cell balancing, state estimation, and fault detection for the battery pack [71].

Moreover, safety standards have been established by organizations such as IEC, IEEE and ISO, which require performing tests on the batteries before usage, to show that it can tolerate thermal, electrical, and mechanical abuse to reduce the risk of thermal runaway. Some of the tests are, overcharge test, forced discharge test, nail penetration test, crush tests, external short circuit test [75]. And these tests are conducted to ensure that the LIBs meet the specified criteria.

In addition to hazard levels that classify the response of the battery to abuse conditions. For example, if the level is zero, then there is no damage or loss of functionality, if level is 1, then the passive protection is activated, meaning that there is no hazard or damage, but protection activated and needs resetting or replacement. Going all the way to level 7, which is an explosion, meaning very fast energy release causing pressure waves causing damage. These levels are used to evaluate the abuse response of the batteries [74].

3.7. Reliability and quality control

Lithium-ion batteries are widely used in EVs, consumer electronics, and energy storage systems. Therefore, ensuring their reliability and maintaining quality control is very important for good performance, safety and longevity [76].

Factors affecting reliability: during the manufacturing process, factors such as chemical impurities and corrosion can impact battery reliability [76].

In addition, design features such as vents, internal and external fuses are important for performance and might affect the reliability of the battery [76].

Finally, thermal management and effective thermal regulation are important, to prevent overheating, which is a common cause for battery failure. In addition, thermal management can lead to thermal runaway, putting safety at risk [76].

Quality control measures: developing methodologies and tests to detect and diagnose faults, to help understand failure mechanisms and implement preventative measures [77]. In addition to selecting appropriate materials and designs and following designs protocols to enhance reliability [78].

Advanced monitoring and management systems: first the Battery management systems [BMS], which are crucial for monitoring parameters such as voltage, current and temperature, ensure a safe operation of the LIBs [63].

Second is machine learning techniques, using algorithms to enable accurate estimation of battery and a prediction of remaining useful life, to facilitate the maintenance and ameliorate the reliability of LIBs [79].

3.8. Cost of a lithium-ion battery

In this section, an analysis of the cost of a lithium-ion battery will be shown, covering the whole process, starting from material extraction to the end of useful life, and recycling [80].

According to [80] a breakdown of the cost of a lithium-ion battery, from cradle to grave, which means from the raw materials extraction until recycling and end of life. The analysis will be shown in table 3.

Table 3: Cost of every Life Cycle stages.

Life cycle stage	Cost \$ per kWh	References dates
Cathode active material synthesis	\$45.0	2024
Other electrode manufacturing	\$26.1	2024
Cell assembly	\$13.4	2024
Cell conditioning	\$10	2024
Recycling	\$6.8-\$8.6	2024
TOTAL Cost	\$103.5 per kWh	2024

Cathode active material is the production of the cathodic material used in the LIB, for example, lithium, nickel and cobalt. This step of the process has the highest cost of whole process (\$45.0). It contributes around 48% of the total cost.

The manufacturing of the other electrode means the anode (graphite) as well as the processing of the electrodes.

The cell assembly includes the assembly of the electrodes, electrolytes, separators, and the case of the cell.

Cell conditioning includes first the formation of the solid electrolyte interphase (SEI) layer. Second, the battery aging, which means assessing the battery for any non-conformities. Finally, the quality control tests were performed on the battery.

The subtotal cost of the battery excluding the recycling process is **\$94.5 per kWh**.

Adding to the total, the cost of the recycling process, using the hydrometallurgical method, used to recover the materials using chemical solutions. This method dissolves the materials and extracts the metals. It is cost effective and is environmentally

friendly. The total cost of the entire process from cradle-to-grave is now estimated at \$103.5 per kWh.

The paper of Gutsch et al. 2024 includes neither the transportation cost, nor the maintenance costs. Therefore, sources [81] and [82] showed the cost of the transportation and maintenance respectively. The transportation cost is divided into many stages, as shown in the table 4 [82]:

Table 4: Cost of transportation.

Transportation stage	Cost \$ per kWh	References dates
Raw material transportation	\$1.0-\$2.5	2025
Cell transportation	\$0.5-\$1.5	2025
End-of-life transportation	\$1.5-\$3.0	2025
Total transportation cost	\$3.0 - \$7.0 per kWh	2025

The raw materials transportation is from the mining site to the factory, for example from China to Europe [82].

Cell transportation from the factory to the assembly plant, safety precautions must be taken [82].

Finally, the transportation to the recycler in the end-of-life stage of the battery [82].

Therefore, the total estimated cost for transportation ranges between \$3.0 per kWh and \$7.0 per kWh depending on the locations, either global or local supply chains, and depending on the safety precautions that need to be taken into consideration [82].

The maintenance cost is divided into different sections, as shown in table 5 [81]:

Table 5: Cost of Maintenance.

Maintenance	Cost \$ per kWh	References dates
Battery management system (BMS)	\$1.5-\$3.0	2025
Cooling and thermal management	\$1.0-\$2.0	2025
Repairs and module replacements	\$1.0-\$2.0	2025
Total maintenance cost	\$3.5-\$7.0 per kWh	2025

The BMS maintenance includes software updates, diagnostics and safety checks [81].

The cooling and thermal maintenance is done regularly, to maintain a safe battery temperature [81].

The repairs and replacements are done only in case of aging or failed components [81].

But the total estimated cost for maintenance range between \$3.5 per kWh and \$7.0 per kWh, and it varies based on the application where the battery is used. For example, for EVs battery, the maintenance is negligible, because the battery pack is sealed, and the maintenance comes under warranty. In grid-scale applications, maintenance is done regularly and includes diagnostics, thermal management and software updates [81].

Finally, summing up all the additional, external costs of the battery, the estimated cost of a battery ranges **between \$110 per kWh and \$117.5 per kWh**.

However, the above study of Gutsch and Moritz 2024, is done in 2023 with a battery cost of \$94.5 per kWh without external expenses. Looking back, In 2016, the average cost of LIBs was \$324 per kWh [80]. By 2021, battery pack price decreased to \$138 per kWh. In contrast, Looking forward, with the increase in the demand for EVs, and energy storage in general, LIB cost is declining further, might reach \$70-\$80 per kWh by 2030 which is almost 50% less the cost in 2021 making EVs more cost-competitive [83].

3.9. Application of Lithium-ion battery

An investigation of different applications of lithium-ion battery will be undertaken, in different fields, such as transportation, power grid applications and consumer electronics.

3.9.1. Residential energy storage

One of the applications of the lithium-ion batteries is residential energy storage. It stores electricity coming from solar panels or grids and provides electricity backup in case of an outage and enables energy independence. For example, Tesla has a model called Powerwall 3, consisting of rechargeable lithium-ion battery system [84].

The type of lithium-ion battery cells used in Powerwall 3 are the lithium iron phosphate (LFP). In previous models, Powerwall 2, Tesla used the lithium nickel manganese cobalt oxide (NMC). This transition was made because LFP are much safer, have longer lifespan and thermal stability, while NMC needed precise thermal regulation due to its limited operating temperature and increased risk of thermal runaway at high temperature [84].

The nominal battery energy is 13.5 kWh, while the power rating is 11.5kW continuous output, so it is suitable for powering home appliances. This model can operate in a temperature range between -20°C to 50°C, having an efficiency up to 97.5% (without

considering the environmental conditions and how frequent the charging and discharging) [84].

The Powerwall 3 can be connected through Wi-Fi, Ethernet, and cellular. In addition, multiple Powerwall units can be connected to increase the storage capacity for larger applications (up to 7 units), and it has a lot of integrated protection. Finally, it has its own Tesla mobile app, through which the customer can monitor the energy consumption, receive alerts and change its settings [84].

3.9.2. Electric Vehicles

Nowadays, one of the main applications of lithium-ion batteries is electric vehicles. Since batteries are an essential element in the EV, it is important to choose the best quality and best performance possible. For example, the Tesla model 3 is an electric car that uses lithium iron Phosphate battery pack [85], [86].

The nominal battery energy is 55 kWh, while the usable energy is 49.8kWh with an energy consumption of 117Wh/km when operating in normal conditions. The energy density of this battery is 125 Wh/kg, the power density is 527W/kg, and the nominal voltage is 339.2V, in addition to a cell capacity of 161 Ah [85], [86].

The model 3 uses type 2 and CCS charging ports, with AC and DC charging capabilities. The charging time takes 6 hours and 15 minutes to fully charge, while fast charging takes 24 minutes [85], [86].

Another example, the electric bikes and electric scooters, which use much lower values. For instance, E-gap Engineering developed a battery model, called Light Duty (LD) MODEL and is used in such applications with limited space and weight [87].

The chemistry used in these batteries is the lithium nickel manganese cobalt oxide (NMC), with a rated voltage of 14.5V, rated energy of 2.9 kWh and a capacity of 116Ah. The LD module can be also applicable in boats and tractors [87].

3.9.3. Grid scale Energy Storage

A utility-scale battery energy storage system (BESS) is a potential solution to increase power system flexibility, in presence of variable energy resources such as, solar and wind. The BESS can absorb quickly, hold and reinject electricity. For instance, ABB designed a 4.0 MWh Utility-scale BESS based on the IEC standards. The chemistry used is LFP, which is very safe, and has a long lifespan. There are 16 battery racks, arranged in 2 module setups. Followed by two 1 MW power conversion systems for DC-AC conversion [88].

The storage capacity of the system is 4.0MWh, with a rated power output of 2MW [88].

The system is protected using ABB's circuit breakers and disconnectors, to make sure that the protection is fast when needed, for a safe operation [88].

In addition, the system is controlled and monitored by an energy management system (EMS), for a real time monitoring of the operations [88].

Another example is the SmartLi series, a battery energy storage system developed by Huawei. It is used in applications such as datacenters in headquarters or disaster recovery data centers. The battery chemistry used is LFP, the safest cell of LIB, no fire after thermal runaway, less risk with cycle life of 5000 cycles. The nominal capacity is 162Ah / 82.94 kWh, considering a full cabinet of 2 groups of eight batteries each. With a design life of 15 years. And an operating temperature ranging between 0°C and 40°C, but it is preferable to be between 20°C and 25°C [89].

3.9.4. Consumer Electronics

Not only lithium-ion batteries are used in grid scale applications and electric vehicles, but also, it is used in daily use appliances, such as phones, laptops, chargers, power banks, etc... Taking as an example the Panasonic industry, which manufactures batteries to supply diverse needs. For instance, Panasonic NCR18650B is used in applications such as laptops, power banks and flashlights. The chemistry used in this battery is the nickel Aluminum Oxide (NCA). It has a capacity of 3400mAh and a nominal voltage of 3.6V [90].

3.10. Future of Lithium-ion battery

Thanks to its remarkable characteristics, lithium-ion batteries are one of the most used batteries nowadays. LIBs are becoming popular, especially in the field of electric vehicles, due to their high performance and light weight. Studies are always being done on LIBs, to find ways to make them safer to use, especially at low/high temperatures. In addition, to finding ways to make the batteries more ecofriendly, because they have environmental impacts, considering that CO_2 is emitted during their production. Also, some of the cathodes used in LIBs, such as cobalt and nickel, lead to global warming and have an impact on human health. The demand for lithium-ion batteries has been steadily increasing over the years, despite their relatively high cost. However, this growing demand may contribute to a reduction in costs over time [7], [91].

4 Carbon footprint of Lithium-ion Battery

To analyze the carbon footprint of a lithium-ion battery, the life cycle of the battery should be specified, and the Life cycle assessment method should be used, which will be explained in this chapter.

4.1. Life cycle of LIB

The lifecycle process of a lithium-ion battery, from raw material to recycling, involves many stages. These stages are crucial for understanding the environmental impacts associated with LIBs [92]. The stages are:

4.1.1. Raw material acquisition

This initial stage involves the mining and extraction of various raw materials, such as, lithium, cobalt, nickel, manganese, aluminum, copper, and graphite. These raw materials are processed and refined into battery-grade materials. This phase is a significant contributor to the environmental impact of LIBs [92].

4.1.2. Components manufacturing

In this second stage, the processed raw materials are used to manufacture the individual components of the battery, such as the cathode, anode, electrolyte and separator. And for the creation of these components, a considerable amount of energy is needed [92].

4.1.3. Battery assembly

The manufactured components are then assembled into battery cells, modules, and battery pack. This stage involves engineering and quality control to ensure the battery's performance and safety [92].

4.1.4. Transportation

It includes several transports, for instance, the transport of raw material to the processing facility, components assembly plants, and the assembled battery to their point of use. In addition to the transport of the batteries at their end-of-life to recycle or disposal [92].

4.1.5. Use phase

In this stage, the LIB is used for specific applications, such as EVs, and stationary energy storage systems. The environmental impact in this phase depends on the energy required to carry the battery weight, the energy conversion losses in the battery and the carbon intensity of the power used for charging [92].

4.1.6. End-of-Life

Either recycling or disposal: once the battery reaches the end of its useful life, due to degradation mechanisms, leading to poor electric mobility, it enters this phase. Recycling can recover materials such as lithium, cobalt, nickel, and manganese. And it is beneficial for the environment since; less extraction of raw material is done [92].

4.2. Lifecycle assessment (LCA)

As mentioned above, all the lifecycle stage exhausts a lot of energy and has environmental impacts such as the greenhouse gas emission. Therefore, a lifecycle assessment is used as an analysis tool to quantify the potential environmental consequences throughout the whole lifecycle. The main goal of LCA is to determine and overcome the environmental impacts caused by the production and usage of the LIBs [92], [93], [94].

LCA is characterized by a four-phase methodology standardized by the ISO 14040 and 14044 regulations: The first is the **goal and scope phase** which define the objectives, functional unit, system boundaries, and impact categories of the study. The functional unit defines what is being studied and assigns a reference which the input and output are related to. For example, in EVs the functional unit is the distance travelled [92], [93], [94].

The second is the **life cycle inventory (LCI)** which involves evaluating the amount of material and energy consumption, and the waste and emissions, during the life cycle of the battery. In other words, it's the phase where the data is collected on the input and outputs of the whole process within the boundary. The data can be either primary, which means collected directly from the manufacturers, or secondary, which means obtained through a database such as Ecoinvent or a previous study [92], [93], [94].

The third is the **life cycle impact assessment (LCIA)** which focuses on converting the results of the LCI into environmental indicators. For example, global warming potential (GWP) is expressed as Kg CO_2eq . The conversion is done using different methods, such as, IPCC, ReCiPe, GREET. In other words, it consists of multiplying the LCI result by an emission factor, which is different for each material, to express the result into environmental indicator [92], [93], [94].

Finally, the fourth is the **interpretation**, where the results from LCI and LCIA are analyzed based on the goal and scope. In addition, checking the sensitivity of the analysis and how the results are affected by the parameters of the battery (such as efficiency, battery lifetime, driving distance for EVs...). The sensitivity of the analysis is meant to show how the results of the environmental impact, such as global warming potential, changes when the data of different parameters, such as transportation, energy used, recycling rate, vary [92], [93], [94].

4.2.1. Models of LCA (system boundaries)

The models are the system boundaries where the LCA is applied, meaning which lifecycle stages are included in the assessment [92]:

Well-to-wheel: this strategy focuses on fuel and is used in 18% of the investigations. It is mainly used in vehicle assessments [92].

Cradle-to-gate: it is focused on fuel and is used in 38% of the work. It considers the impact of raw materials extraction (cradle) up to when the product leaves the factory (gate) [92].

Cradle-to-grave: this strategy considers the whole lifecycle stages of the battery. It is used in 18% of the work. It considers the impact of raw materials extraction (cradle) up to the disposal or recycling (grave), considering the end of life (recycling) phase [92].

4.2.2. LCA impact categories

LCA impact categories represent different types of environmental effects that are assessed in the LCA process. The selection of the impact category must be done based on the ISO 14044 and ISO 14040 standards. These standards state the requirements for the LCA assessment, explaining what the study objective should include, the intended audience, the time scope, and the limitations of the study. Moreover, ISO 14044 emphasizes that the selection of LCA impact categories must be aligned with the goal of the study [92].

Arshad et al. (2022) conducted a review, by re-examining existing research on the environmental impact of lithium-ion batteries. So, in this review 80 LCA studies on LIBs, performed between the period from 2010 to 2021, were selected, to check and categorize the LCA impact from the highly existent to the lowest [92].

Therefore, figure 19 represents the different categories and how they are divided into different environmental categories, such as, global warming, depletion, ecotoxicity, and many more.

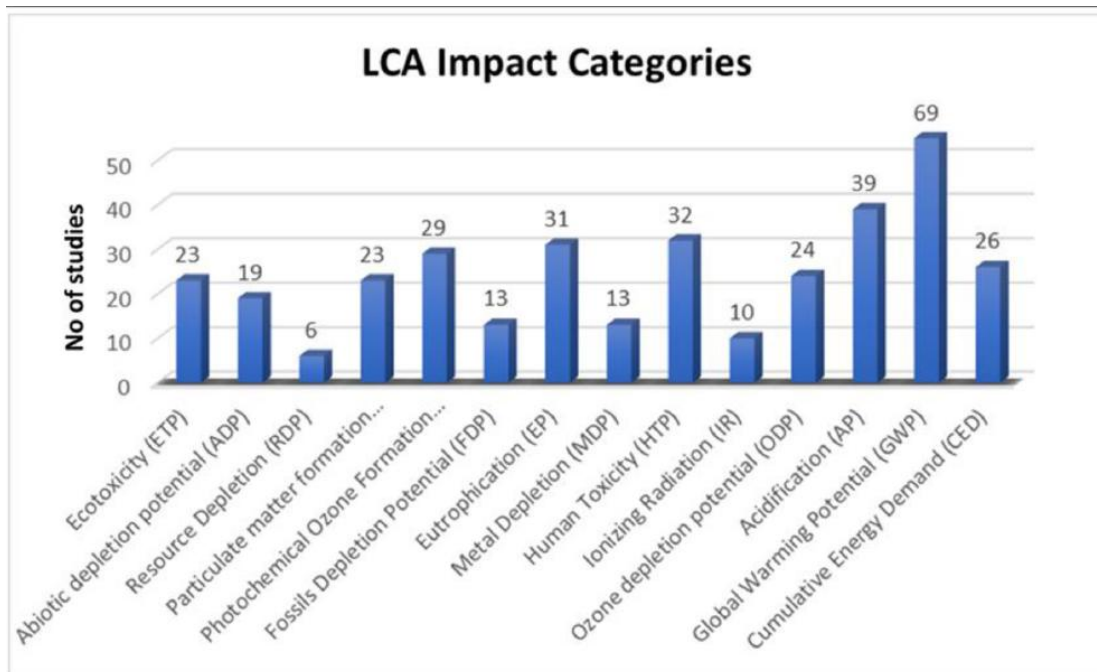

Figure 19: different LCA impact categories [92].

As seen in figure 19, a list of impact categories is presented based on the 80 research.

For example, the global warming potential (GWP) is the most used impact category in 69 out of 80 studies. GWP measures the radiative forcing of greenhouse gases compared to CO₂.

Another example is the acidification potential (AP) which was used in 39 out of 80 studies, which is the potential of chemicals such as, such as nitrogen oxides, and sulfur oxide, to acidify the environment.

While the least used impact category is the resource depletion (RDP), used only in 6 out of 80 studies. RDP refers to the consumption and exhaustion of the use of natural resources.

Based on this analysis, during an LCA assessment, the most frequently used LCA impact category is the global warming potential.

In summary, the core of the LCA is to count the material and energy input of every phase and calculate the direct and indirect emissions of every stage [95]. Direct emissions are caused by the material and energy consumption in every phase, while indirect emissions are caused by the traceable energy and raw materials [95].

Now that the methodology of LCA is established, it can be used to quantify and calculate the greenhouse gas emissions, also known as, carbon footprint. It includes carbon dioxide CO₂, methane CH₄, nitrous oxide N₂O, hydrofluorocarbons HFCs, and perfluorocarbons PFCs. All these elements are represented in terms of CO₂ equivalent (CO₂eq) [95].

So, the following block diagram in figure 20 represents the process to calculate the carbon footprint using LCA:

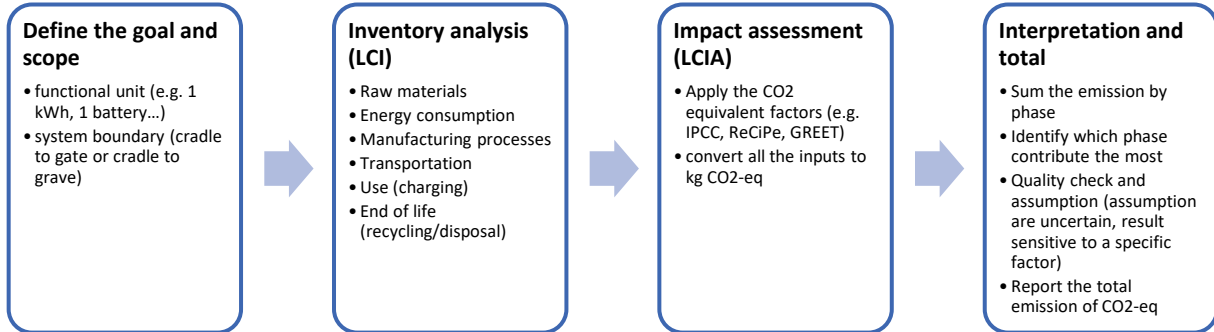

Figure 20: LCA assessment steps block diagram.

As seen in figure 20, the steps to perform the LCA assessment are mentioned respectively and are always applied in the same way.

4.2.3. Calculate the carbon footprint for each type of lithium-ion battery, using the LCA assessment

To calculate the carbon emissions for LCO, NMC, LTO, LFP, NCA LMO, and solid-state batteries, sources such as Dunn et al. 2015 [96], Dunn et al. 2012 [97], Sadhukhan and Christensen 2021 [98], Julia DAMSTRÖM [8], and Wu et al. 2023[95], are used in order to gather all the data needed to formulate two excel sheets. The first sheet contains the life cycle inventory data per kWh usable capacity. And the second one contains the emission factor per Kg CO₂-eq/kg. To get the emission factor, the data was taken from the sources, and the following formula was applied:

$$\text{Material emission factor} = (\text{material production energy, MJ/kg}) \times (\text{average CO}_2 \text{ intensity, kg/MJ})$$

Therefore, the two Excels are as follows:

Battery_Type	Li	Co	Ni	Graphite	Al	Cu	Energy_Mining	Energy_Manufacturing	Transport_Distance	Recycling_Rate	Energy_Capacity
NMC	0.14	0.11	0.22	0.29	0.18	0.1	500	700	500	70	675
LFP	0.12	0	0	0.29	0.18	0.1	250	300	500	50	515
NCA	0.14	0.05	0.36	0.29	0.18	0.1	550	750	500	70	735
LCO	0.15	0.2	0	0.29	0.18	0.1	600	900	500	80	610
LMO	0.12	0.02	0	0.29	0.18	0.1	300	400	500	50	405
LTO	0.14	0	0	0.29	0.18	0.1	280	350	500	50	100
SolidState	0.14	0.1	0.22	0.29	0.18	0.1	520	750	500	70	940

Figure 21: sample LCI data per kWh usable capacity.

The first excel sheet in figure 21 includes the quantity of material used in the formation of the battery

Battery_Type	Li	Co	Ni	Graphite	Al	Cu	Electricity	Transport	Recycling_Saving
NMC	15	30	20	5	10	8	0.07	0.1	10
LFP	15	30	20	5	10	8	0.07	0.1	10
NCA	15	30	20	5	10	8	0.07	0.1	10
LCO	15	30	20	5	10	8	0.07	0.1	10
LMO	15	30	20	5	10	8	0.07	0.1	10
LTO	15	30	20	5	10	8	0.07	0.1	10
SolidState	15	30	20	5	10	8	0.07	0.1	10

Figure 22: sample of emission factors of material used for LIB production.

The second excel sheet in figure 22 contains the emission factor used to be multiplied with the data from the first database, for each material, to get the exact CO₂ emissions.

Once these sample sheets are present, the second step is to write a code through MATLAB, to read these 2 files and start the calculation as follows:

First, the process is applied the same way, for each type of battery, therefore, a loop is used. The full MATLAB code is in appendix B.

```

% 1- mining and production
Mining_emissions =(LCI.Li .* EF.Li) + (LCI.Co .* EF.Co) + (LCI.Ni .* EF.Ni)+...
(LCI.Graphite .* EF.Graphite) + (LCI.Al .* EF.Al) + (LCI.Cu .* EF.Cu)+...
(LCI.Energy_Mining .* EF.Electricity);

%2- manufacturing
Manufacturing_emissions = LCI.Energy_Manufacturing .* EF.Electricity;

%3- transport
weight_kg= LCI.Li + LCI.Co+LCI.Ni+LCI.Graphite+LCI.Al+LCI.Cu;
weight_tons= weight_kg/1000;
transport_emissions= weight_tons* LCI.Transport_Distance .* EF.Transport;

%4- recycling
total_material_kg=LCI.Li+LCI.Co+LCI.Ni+LCI.Graphite+LCI.Al+LCI.Cu;
recycling_rate = LCI.Recycling_Rate / 100;
recycling_emissions=-recycling_rate .* total_material_kg .* EF.Recycling_Saving;

%5- total emissions per kWh
total_emissions= Mining_emissions+Manufacturing_emissions+transport_emissions+recycling_emissions;

```

Figure 23: MATLAB code including the steps of life cycle of a LIB.

Based on this MATLAB code in figure 23, the process is divided into calculating each step of the life cycle of the battery. For example, in the mining and production, the quantity of Lithium used is multiplied by its emission factor to convert it to CO₂ equivalent, so that the result is in KgCO₂eq. Then this is added to the rest of the materials such as Cobalt, aluminum, and graphite.

For manufacturing, the CO₂ emission is calculated by multiplying the energy used during manufacturing by the emission factor of the electricity.

For transportation, the CO₂ emission is calculated by multiplying the weight of the materials used in tons by the distance crossed and the emissions factor of the distance crossed.

For recycling, the CO₂ emission is calculated by multiplying the recycling rate, negated because this process reduces the emissions rather than increasing it, by the total material weight in Kilograms, and the emission factor of the recycling savings.

Finally, all these results are added together to get the total emission for per kWh in KgCO₂eq. Then it is divided by the energy capacity of the battery that is being analyzed, to get the total emissions per kWh of the battery.

This LCA assessment results in the following table (figure 24):

Battery_Type	Mining_kgCO2eq	Manufacturing_kgCO2eq	Transport_kgCO2eq	Recycling_kgCO2eq	Total_kgCO2eq	Emissions_per_KWh
{'LCO' }	54.3	63	0.046	-7.36	109.99	0.1803
{'LFP' }	23.35	21	0.0345	-3.45	40.935	0.079484
{'LMO' }	27.45	28	0.0355	-3.55	51.936	0.12824
{'LTO' }	25.75	24.5	0.0355	-3.55	46.736	0.46736
{'NCA' }	53.35	52.5	0.056	-7.84	98.066	0.13342
{'NMC' }	48.85	49	0.052	-7.28	90.622	0.13425
{'SolidState' }	49.95	52.5	0.0515	-7.21	95.292	0.10137

Figure 24: Results of the MATLAB code.

Based on the result in figure 24, the mining and manufacturing steps of the lifecycle of a lithium-ion battery has the highest emissions. In addition, the minus that appears in the recycling column means that this is how much recycling saves emissions.

Plot of the emissions of each type of lithium-ion battery for kg CO₂-eq per kWh usable capacity:

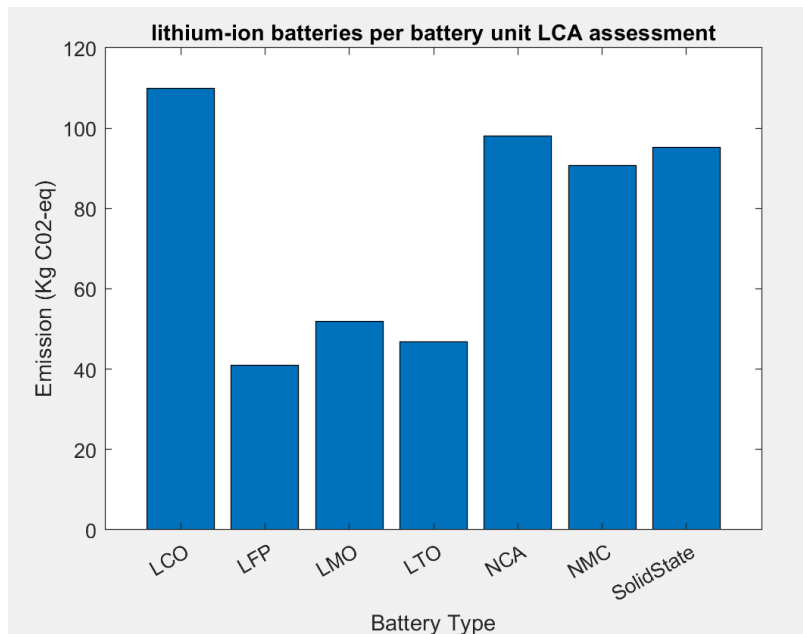

Figure 25: LCA Result in a chart.

So based on figure 25, the transportation step does not really appear, this is because it has very small affection on the carbon emissions.

In addition, LCO has the highest emissions (109 kg CO₂-eq per kWh) compared to all other types of LIBs. While LFP has the lowest emissions (40 kg CO₂-eq per kWh).

The LCA assessment is not complete without doing a sensitivity analysis, to evaluate the change of the global warming potential, for the data of different parameters.

The analysis will be done based on recalculating total emissions while varying the electricity emission factors and using the same method used above and checking how the change affects the LCA result.

The plot result is as follows in figure 26:

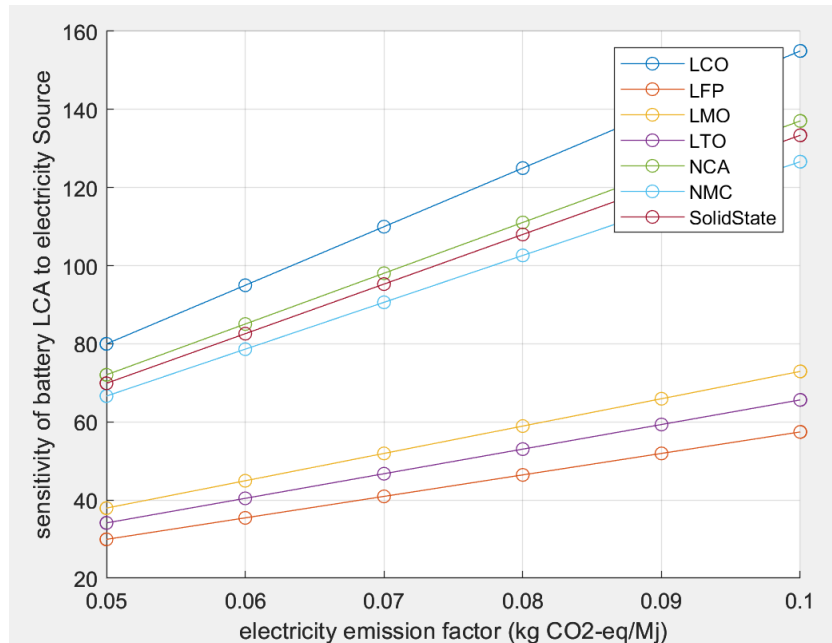

Figure 26: Sensitivity analysis results.

This plot in figure 26 shows how much each battery's LCA is affected by the electricity source. While increasing electricity emissions, the carbon emission of the battery increases significantly. For instance, the LCO emissions went from 80 kg CO₂-eq per MJ to 155 kg CO₂-eq per MJ. Another example, the LFP emissions went from 30 kg CO₂-eq per MJ to 58 kg CO₂-eq per MJ.

Therefore, it is clear the LCA result of the battery is sensitive to the electricity emissions.

4.2.4. Comparison between the sources and the MATLAB calculations

Now, compare the obtained results with the ones from the sources:

Based on the sources mentioned at the beginning of this section, the carbon footprint in kg CO₂-eq per kWh of the LCO is between 120 and 130 kg CO₂-eq per kWh, LFP is between 30 and 50 kg CO₂-eq per kWh, LMO is between 35 and 45 kg CO₂-eq per kWh, LTO is between 50 and 60 kg CO₂-eq per kWh, NCA is between 110 and 120 kg CO₂-eq per kWh, NMC is between 100 and 120 kg CO₂-eq per kWh, Solid state is between 100 and 110 kg CO₂-eq per kWh.

While based on the MATLAB calculations the carbon footprint in kg CO₂-eq per kWh of the LCO is 109.99 kg CO₂-eq per kWh, LFP is 40.93 kg CO₂-eq per kWh, LMO is 51.9 kg CO₂-eq per kWh, LTO is 46.73 kg CO₂-eq per kWh, NCA is 98 kg CO₂-eq per kWh, NMC is 90.62 kg CO₂-eq per kWh, Solid state is 95.29 kg CO₂-eq per kWh.

Table 6: Comparison table between the obtained values and the values from the sources.

Carbon footprint in kg CO₂-eq per kWh	From the sources	From the MATLAB calculations
LCO	120-130	109.99
LFP	35-45	40.93
LMO	110-120	51.93
LTO	100-120	46.73
NCA	30-50	98
NMC	50-60	90.62
Solid state	100-110	95.29

Based on table 6, there is a difference between the values of the articles and the values calculated, this is due to the accuracy of the sample data used. In real applications to calculate the carbon footprint emission of a battery, the databases can be either collected directly from the manufacturer or using databases such as Ecoinvent database.

4.2.5. Strategies to reduce carbon footprint

One of the strategies is mentioned in the choice of recycling method. For example, using cascade utilization of the battery, which reduces the carbon emissions by 1.536 kgCO₂-eq/kWh; in addition to using methods like hydrometallurgy which reduces the carbon emission of 13.3 kgCO₂-eq/kWh [95].

Another strategy is to transition to a cleaner electricity mix by increasing the proportion of renewable energy sources, because a big portion of the carbon emissions of the EV battery comes from the electricity used in the production phase [95].

Finally, ameliorating the production process, by improving the efficiency of the material extraction and processing, components manufacturing and battery assembly. In addition to improving the recovery network for the end-of-life battery, by optimizing the logistics and transportation [95].

5 Lithium-Ion vs Solid-State Batteries

Recently, the most important comparison was the one made between Lithium-ion batteries, and solid-state batteries. Since, they are relatively close, with some differences, advantages, and disadvantages from one another. The main advantage of the solid-state over the lithium-ion is having solid electrolytes which are much safer and less flammable than liquid electrolytes that are in the LIBs.

5.1. Lithium-based Solid-State batteries

Before comparing the two types of batteries, an explanation of lithium-based solid-state batteries should be introduced [40], [41], [43].

5.1.1. Composition of a solid-state battery

Lithium based solid state batteries are composed of anode, cathode, and electrolyte.

Electrolytes: what makes them different from the ones in LIB is that here solid electrolytes are used. They have high ionic conductivity, very low electronic conductivity, and high degree of chemical stability. They act as an ionic conductor, to move the Li-ion, and as a separator between the electrodes [40], [41], [43].

Solid electrolytes can be either inorganic (crystalline material) or organic (polymer based) or a hybrid, a mix of both [40], [41], [43].

And it can be classified as either being bulk, having a thickness in the range of several hundreds of micrometers. Or thin film, much thinner than bulk, ranging from hundreds of nanometers to several microns [40], [41], [43].

Anode: the use of solid electrolyte acting as separator enables the use of pure lithium metal as anode material. And when using lithium metal anode, an increase in volumetric energy density, up to 70%, is seen, compared to the LIBs with conventional anodic materials such as graphite. Nevertheless, using pure lithium metal anodes has its drawbacks. One of the drawbacks is not being able to use them in high temperature conditions, because they are very sensitive to high temperature, which might lead to the failure of the anodes, in addition to safety risks. Another drawback is the dendrite formation resulting from the non-uniform current density across the cell, which leads to local temperature gradient in the cell. This might also lead to the depletion of the lithium causing short circuit of the cell [40], [41], [43].

Cathode: it supplies the battery with the necessary ions during charging and discharging. It must be stable and have good ionic conductivity.

As with other batteries, different types of solid states are introduced. These different types of solid states depend on the solid electrolyte material used instead of liquid. Therefore, solid electrolytes are **inorganic solid electrolytes**, for example: **oxides** such as Lithium lanthanum titanate (LLTO), Lithium based superionic conductor (LISICON). **Sulfides** including glassy sulfides (e.g., $\text{Li}_2\text{S-SiS}_2$, $\text{Li}_2\text{S-P}_2\text{S}_5$, $\text{Li}_2\text{S-GeS}_2$) and glass-ceramic sulfides, often combined with other compounds like Li_3N or LiI . And **glass systems** including $\text{AgIeAg}_2\text{SeO}_4$, thiosilicate glasses¹⁸, thin film lithium borate based glassy electrolytes¹⁸, oxynitride electrolytes like LiPON. The second type is the **organic solid electrolytes**, which is polymer-based, they consist of a lithium salt dissolved in a polymer matrix, such as polyethylene oxide (PEO) or polypropylene oxide complexed with Li salts [40], [41], [43].

The last type is the **hybrid solid electrolytes**, which are a mixture of organic and inorganic electrolyte, such as a combination of oxides and polymers [40], [41], [43].

5.1.2. Electrical parameters of a solid-state battery

The important parameters to look at when analyzing solid-state batteries are as follows:

Table 7: Electrical parameters of SSBs.

Parameters	Value	References dates
Ionic conductivity	$1.7 \times 10^{-2} \text{ S cm}^{-1}$ for $\text{Li}_2\text{SeP}_2\text{S}_5$, at room temperature	2014, 2018, 2021
Voltage range	2.5-4.5V depending on cathodic material	2014, 2018, 2021
Energy density	From 200 to 400 Wh. Kg ⁻¹ theoretical potential	2014, 2018, 2021
Cycle life	1000-5000 depending on the material	2014, 2018, 2021
Operating temperature	-30°C to 45°C, can tolerate up to 200°C	2014, 2018, 2021

The ionic conductivity measures how easily the lithium ions flow through the solid electrolytes. That is why it is an important parameter when analyzing the SSB. Based on table 7, considering the lithium selenide phosphate sulfide, they have a conductivity of $1.7 \times 10^{-2} \text{ S cm}^{-1}$ which is considered high. Another important

parameter is that SSBs can tolerate up to 200°C and still operate, this is due to the presence of the solid electrolytes that are non-flammable and do not lead to thermal runaway [40], [41], [43].

5.1.3. Safety of a solid-state battery

A major advantage of solid-state batteries is their enhanced safety compared to conventional LIBs that use flammable liquid organic electrolytes. They eliminate hazards such as fire, leakages, and thermal runaway. In addition, solid electrolyte acts as physical barriers that prevent the formation of lithium dendrites, which are a major cause of explosion in a typical liquid electrolyte battery. Therefore, solid state is used in applications such as cardiac pacemakers, because of their high safety [40], [41], [43].

5.1.4. Cost of a solid-state battery

The cost of a solid-state battery is reported to exceed 100\$/kWh in 2025 and was reported in 2023 to range between 430 to 2500 \$/kWh. The cost is considerably high; this is due to many factors affecting it. For example, the expensive raw materials and the limited mining amount of lithium. In addition, the complex manufacturing processes due to the solid electrolytes in the SSB, which are highly sensitive to moisture, and therefore require special dry rooms, which adds up the cost. In addition to the low production volume of the SSB, which means only a small number of solid-state batteries are being made, and the factories and supply chains are still in early stages. Thus, not enough of these batteries is produced which leads to higher price [99] [100].

Nevertheless, three scenarios have been suggested for the future, based on the historical LIBs trends and market analysis. The first is the optimistic scenario considering the lowest price of 430\$/kWh in 2023, with higher production, the price will go down to 140\$/kWh in 2028. Based on this scenario the estimated price in 2025 will be 314\$/kWh. The second is the moderate scenario, considering the average price of 1465\$/kWh in 2023, the price will go down to 286\$/kWh in 2030. Based on this scenario the estimated price in 2025 will be 1128\$/kWh. Finally, the pessimistic scenario, is considering the highest price of 2500\$/kWh in 2023, the projected price will go down to 480\$/kWh in 2030. Based on this scenario the estimated price in 2025 will be 1923\$/kWh [99] [100].

All these predictions are based on the potential increase in the production of solid-state batteries, driven by higher demands.

5.2. Comparison between Solid-State and Lithium-ion batteries

The comparison between LIBs and solid-state will be made based on the electrical parameters, safety matters and cost.

5.2.1. Electrical parameters comparison

Starting with the electrical parameters of both batteries including voltage, energy density, cycle life and operating temperature, the comparison is seen in table 8.

Table 8: Comparison table between LIBs and SSBs.

Parameters	Lithium-ion battery	Solid-state battery
Voltage range (V)	2.5-5	2.5-4.5
Energy density (Wh.kg)	200-750	200 to 400
Cycle life (cycles)	500-7000	1000-5000
Operating temperature	-20°C to 60°C	-30°C to 45°C, can tolerate up to 200°C

Keeping in mind that all these values depend on the material used, in general, based on table 8, the LIB acquire higher energy density and cycle life, while the SSB can tolerate higher temperature, while still working properly.

5.2.2. Safety comparison

A key reason for an improved safety of the SSB compared to the LIB is replacing the liquid electrolyte using in traditional LIB with a solid electrolyte, as explained before. Which makes the SSB advantageous compared to the LIB, safety wise, as the solid electrolytes, are less flammable and less exposed to leakages compared to the liquid electrolytes [99].

5.2.3. Cost comparison

Based on the analysis done in section 3.8 for the cost of lithium-ion batteries and the analysis done in section 4.1.4 for the cost of solid-state batteries, the following table can be drawn:

Table 9: Cost comparison and prediction between LIBs and SSBs.

Year	Lithium-ion battery	Solid-state battery (optimistic scenario)	Solid-state battery (moderate scenario)	Solid-state battery (pessimistic scenario)
2023	110-117.5\$/kWh	430 \$/kWh	1465\$/kWh	2500\$/kWh
2030	70-80\$/kWh	140\$/kWh	286\$/kWh	480\$/kWh

Based on table 9 and considering the different scenarios for the SSB cost, the SSB is disadvantaged in this comparison because, in any of the cases, the Lithium-ion battery is always significantly lower in price than the solid-state battery.

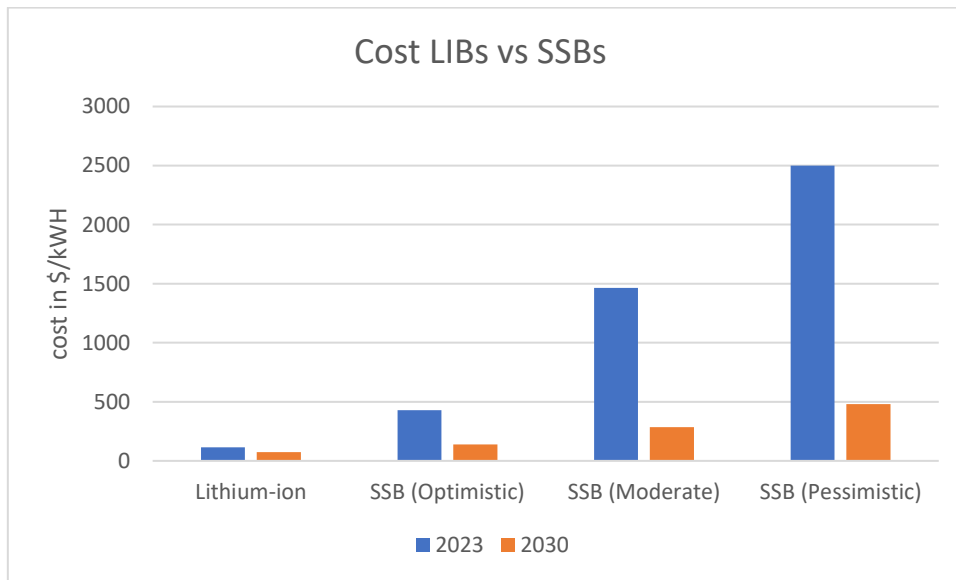

Figure 27: comparison chart between LIBs and SSBs.

Based on the chart in figure 27, even if the cost of SSB might potentially decrease over the years, the closest that it can get is when considering the optimistic scenario of the solid state. Otherwise, the LIBs have lower cost than the SSB.

6 Hybridization of batteries

Hybridization is the concept or process of integrating two or more systems or technologies together, to improve the operation and the performance of the system. In the case of batteries, lithium-ion batteries can be hybridized with other energy storage to overcome some weaknesses of the LIBs, and improve the performance, the power and energy, the durability and safety. For example, LIBs can be hybridized with solid state batteries to overcome the safety issues, such as flammability of the LIBs. In addition, LIBs can be hybridized with supercapacitors providing higher power and faster charge/discharge. Solid-state batteries can be hybridized as well with supercapacitors, with the same purpose [101].

In the following section, a comparison between LIBs hybridized with supercapacitors and solid-state hybridized with supercapacitors, covering their electrical properties, safety, and costs.

6.1. Hybrid configuration

Supercapacitors (SC) are used in both configurations, hybridized with either lithium-ion batteries or solid-state batteries. It is an energy storage element that ranges between a few farads to hundreds of thousands of farads. Moreover, all the characteristics of a capacitor stayed the same, such as, fast discharge rate while having higher storage capacity [101], [102].

Three different types of supercapacitors exist: the first is Pseudo-capacitors (PC), the second is electric double-layer capacitors (EDLC), the third is hybrid supercapacitors (HSC). The electric double-layer capacitor is a widely used supercapacitor, because of its abundant raw materials, low cost, stable performance, and higher cycle life than Pseudo-capacitors. While Pseudo-capacitors have higher energy than electric double-layer capacitors, but lower cycle life. And a hybrid system is used when a very high energy density is needed [101], [102].

In addition, SCs in hybrid systems are less affected by repeated discharge and charge, and so, they can be charged fully in seconds. While the batteries may need an entire day to fully charge again. Therefore, SC provide a rapid discharge/charge cycles and enabling a better-balanced energy distribution for various operational needs. This will help in making the battery safer, and protect it from high-stress discharge current, smoothing fluctuations out, and minimizing battery degradation, while increasing the overall lifespan, performance, and efficiency [101], [102].

Adding to that, in the hybrid supercapacitor, a buffer layer called CNT/PANI help improve the safety by preventing growth of dendrites that can cause short circuits [101], [102].

6.1.1. Lithium-ion batteries and supercapacitors

Lithium batteries and supercapacitors hybrid energy storage system is a promising system. This is because LIBs and SCs can complete the missing features of each other, leading to a stronger product. For example, LIBs have higher energy density, while SCs have higher power density. Therefore, LIBs and SCs, would combine high energy, high power, and a long-life cycle [101], [102].

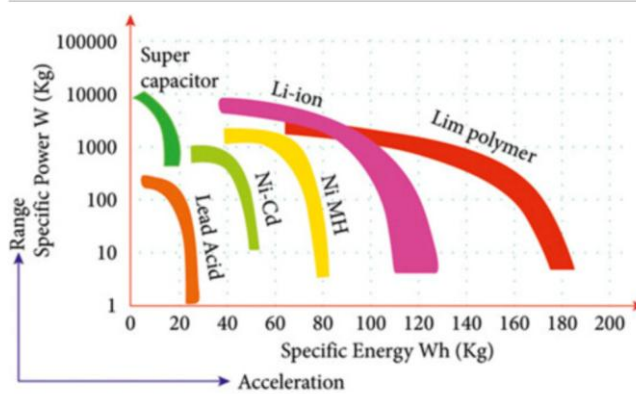

Figure 28: Specific power vs Specific energy for different batteries [103].

Figure 28 shows the proportion between the specific energy and power of different kinds of batteries and supercapacitors. Focusing on the LIBs and SCs, this graph proves what was mentioned above [103].

The hybridization of lithium-ion batteries and supercapacitors is analyzed in terms of electric parameters, safety, cost, and applications.

The following table 10 represent the characteristics of this hybrid system, considering LiFePO₄ as the lithium-ion battery [101]:

Table 10: Characteristics of hybrid system consisting of LIBs and supercapacitors.

Characteristic	Hybrid system value	References dates
Energy density	60-150Wh/kg (change depending on the configuration)	2021
Power density	10^3 - 10^4 W/kg (change depending on the configuration)	2021
Charge/discharge time	Fast capabilities, quick response in millisecond	2021

Cycle life	10 ⁵ -10 ⁶	2021
Operating temperature	-20°C-60°C	2021
Efficiency	90-95%	2021
Cost	90-130 \$/kWh	2018, 2021

Safety: the hybrid system is safe due to all the safety precautions that are present because of the supercapacitor. Nevertheless, the safety risks are not totally gone, because, as previously mentioned, LIB suffer from thermal runaway due to frequent charging/discharging cycles, in addition to the presence of the liquid electrolyte in the lithium-ion battery, which is highly flammable. Therefore, in case of exceeding the operating temperature range will lead to rapid degradation, and potential explosions.

Application: the main application of this hybrid system is electric vehicles. They are also applied in energy storage systems, and microgrids.

6.1.2. Solid-state batteries and supercapacitors

Another configuration is the combination of supercapacitors and a solid-state lithium battery, one study [88], used a quasi-solid-state gel polymer electrolyte, which enhances the safety of the system compared to the conventional liquid electrolyte, with a battery cathode LiFePO₄, and supercapacitor as anode [104], [105], [106].

The hybridization of solid-state batteries and supercapacitors is analyzed in terms of electric parameters, safety, cost and applications.

The following table 11 represent the characteristics of this hybrid system [104], [105], [106]:

Table 11: Characteristics of hybrid systems consisting of SSBs and supercapacitors.

Characteristic	Hybrid system value	References dates
Energy density	180 Wh/kg (change depending on the configuration)	2013, 2017, 2025
Power density	218 W/kg (change depending on the configuration)	2013, 2017, 2025
Charge/discharge time	In minutes, fast	2013, 2017, 2025
Cycle life	10 ⁵ -10 ⁶	2013, 2017, 2025
Operating temperature	-20°C-60°C	2013, 2017, 2025
Efficiency	97% of the initial capacity after 100 cycles	2013, 2017, 2025

cost	200-400 \$/kWh	2013, 2017, 2025
-------------	----------------	------------------

Safety: as mentioned above the use of quasi-solid-state gel polymer electrolyte, which means fewer flammable components, helps diminish liquid electrolyte leakage risks. Therefore, this hybrid system has reduced fire risk significantly. In addition, solid state has higher resistance to mechanical failure, which makes the system safer.

Application: such systems combining high energy density and power density, are important for applications, such as mobile electronics devices, EVs, military-grade high-rate energy storage systems [88], [89].

6.1.3. Comparison of the hybrid systems

Comparing between the two-hybrid system: the lithium-ion batteries combined with the supercapacitors, and the solid-state lithium batteries combined with the supercapacitors. The comparison is made based on the energy and power density, the cycle life, the efficiency, and the cost.

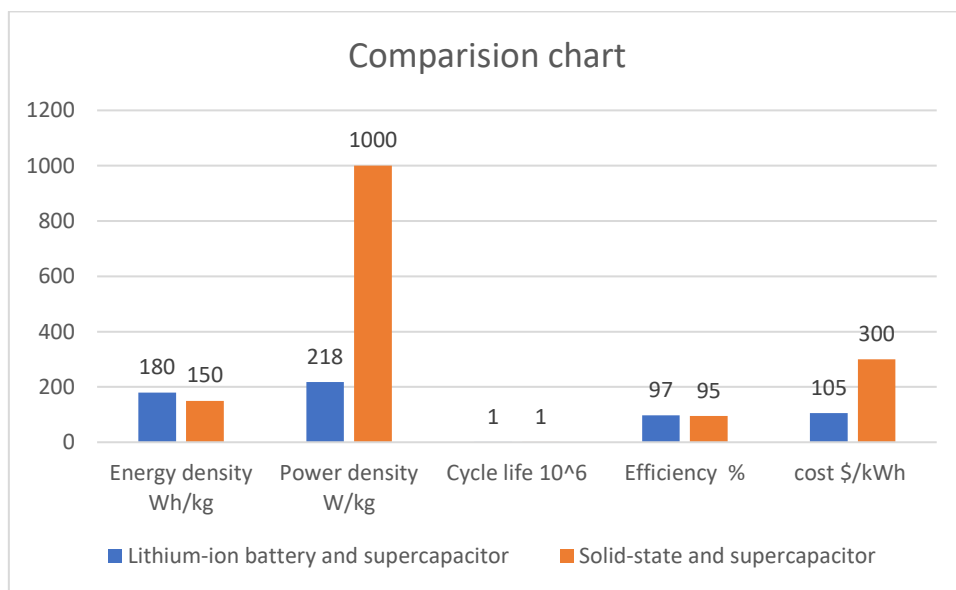

Figure 29: Comparison Chart for different parameters.

Based on the chart in figure 29, using a hybrid system with the LIB instead of the solid state will give higher energy density. And using hybrid system with solid state instead of LIB will give higher power density. But overall, concerning efficiency, cycle life, and temperature, choosing depends on the application that the system is needed in. In addition, currently the main disadvantage of the hybridization of the solid state with the supercapacitor is the high overall cost, it is an average of 300 \$/kWh which is more than two times the cost of the hybridization of the lithium-ion batteries and supercapacitor.

The main difference is in safety, which based on the analysis, it is made clear, based on section 6.1.1 and 6.1.2, that using solid electrolyte will lower the risk of flammability and higher the overall safety of the system. Therefore, safety wise, using a system with solid state battery in combination with supercapacitor will be better.

6.2. System topology and control

The system topology represents how the elements are wired, in series and/or in parallel to achieve a desired voltage and energy level. Therefore, the topology of the system is important. The topologies can be categorized into three types: Passive, active, and discrete [107].

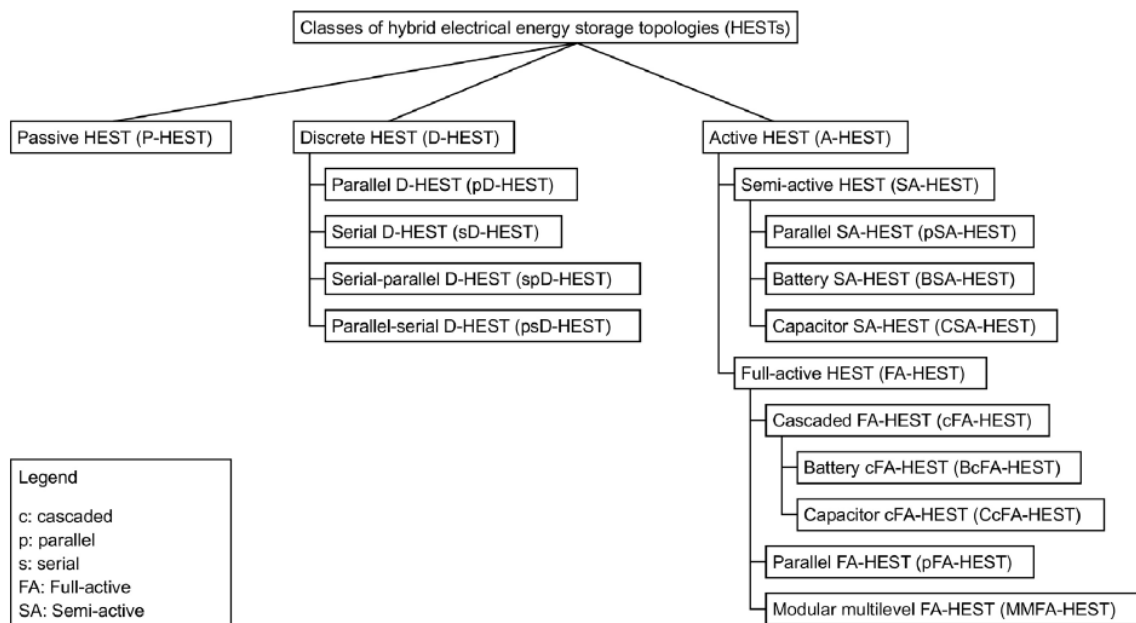

Figure 30: block diagram of hybrid energy storage topology [108].

The block diagram in figure 30 shows all the classes of hybrid energy storage topologies and will be explained in the following section.

6.2.1. Passive hybrid energy storage topology (P-HEST)

The passive hybridization topology is the simplest of all, it only requires connecting the battery cells and the supercapacitors in parallel, where the voltage of both storage devices will be the same as the load voltage. No additional power electronic converters are needed, which means that the energy storage system is directly to the DC bus, then connected to the load. This topology is cost effective, need little space and light weighted, due to the absence of additional power electronics [107].

6.2.2. Active hybrid energy storage topology (A-HEST)

Active hybrid energy storage is not as simple as passive hybrid energy storage, because it includes the addition of dc-dc converters in series with the battery and in series with the capacitor [107].

In this case, there are two types of active hybrid energy storage system:

The first type is the semi-active HEST, where storage devices are connected in parallel, and which uses only one DC-DC converter for one of the energy storage elements (either the battery or the supercapacitor). Which means that only one of the energy storage elements can be controlled. This will lead to a higher cost than the passive system, but also lower cost than the full active system, and lower complexity than the full active system [107].

The second type is the full-active HEST, where each storage device is connected to a DC-DC converter, before the connection to the DC-AC converter. In this topology, both energy storage devices are controlled, this will lead to better efficiency of the system, but using additional power electronics will lead to higher cost, higher weight and more space needed to be installed [107].

6.2.3. Discrete hybrid energy storage topology (D-HEST)

This is the newest hybridization topology; it uses switching elements instead of additional DC-DC converters, so the bigger space and higher weight of the converters is avoided. The switching elements have discrete states: active, bypass, and disable. So, the voltage level and capacity are arranged in discrete steps [107].

Therefore, the topology of the hybridizations is chosen based on the needs of the application, such as the cost, weight, space, controllability, and efficiency [107].

6.3. Implementation of a hybrid system

The implementation of the hybridization of the lithium-ion batteries with supercapacitors was done in Simulink, using the passive topology, meaning that the batteries and the supercapacitor are connected in parallel, then connected to the DC-AC converter and then directly to the load.

It is important to note that the control system dynamics, more specifically, the PWM (Pulse Width Modulation) controlling the three-phase DC-AC converter, play an important role in the performance of the hybrid system. The source does not set the dynamic response of the system; it highly relies upon how this control is organized and implemented. The control system provides the dynamics necessary to allow detailed electrical dynamic analysis. Source control in the context of this study is sufficient to analyse the economic and evaluate the challenges. While the combination of battery and supercapacitor is supposed to be normal theoretically, in actual system

simulations system performance is a function of not only source and control but also of many other parameters like load conditions and converter design.

The Simulink schematic is as follows:

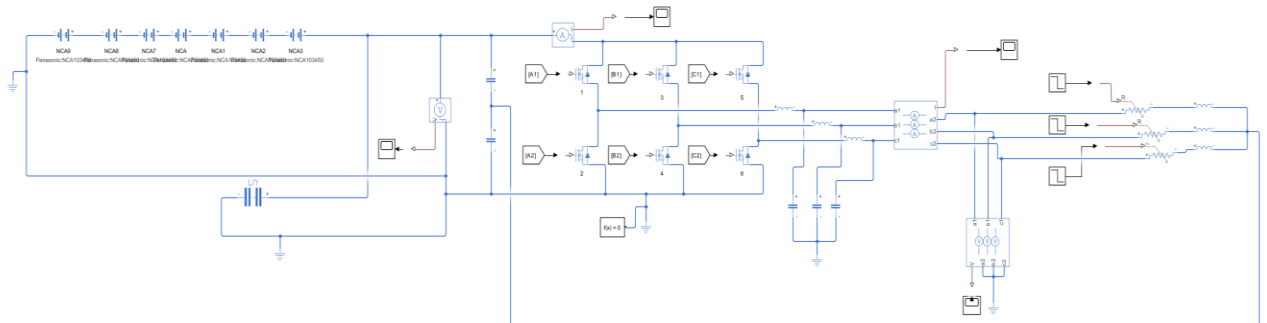

Figure 31: Passive hybrid system schematic.

Based on figure 31, first, the battery model used from Simulink is ‘table based’ which means that a battery model can be selected from a list of batteries. The chosen one in this case is: Panasonic NCA 103450, which has 3.6V per cell. While for the supercapacitor, the cell voltage is 2.7V.

Second, the targeted voltage for the system is around 24V. But it cannot be exactly obtained, then the number of batteries in series needed is 7 batteries (for a total of 25.2V), and the number of supercapacitors in series needed is 10 (for a total of 27V).

Third, the series batteries are connected in parallel to the series supercapacitor, then connected to the DC bus.

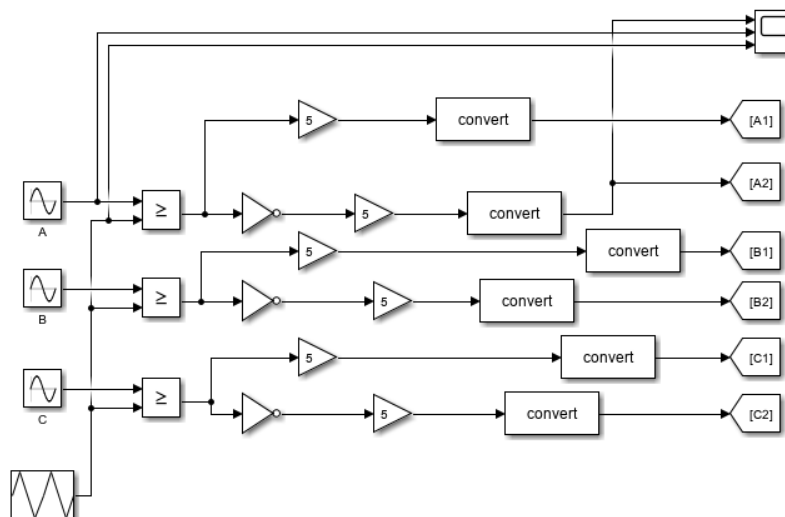

Figure 32: Pulse width modulation schematic.

As seen in figure 32 a Pulse width modulation PWM is used to regulate the inverter switches to get the needed AC output waveform.

Finally, in figure 31, the system is connected to an RL load, with $R = 5.8 \Omega$, and $L = 5 \times 10^{-3} \text{ H}$. These values are chosen considering the targeted power is 100W, then knowing that for the resistance value:

$$R = \frac{V^2}{P} = \frac{24^2}{100} = 5.6 \Omega \quad \text{Eq.7}$$

And for the inductance value:

$$X_L = 2\pi fL \quad \text{Eq.8}$$

$$Z = \sqrt{R^2 + X_L^2} \quad \text{Eq.9}$$

$$\text{And } I = \frac{V_{rms}}{Z} \quad \text{Eq.10}$$

$$\text{Finally, } P = I^2 \times R \quad \text{Eq.11}$$

Putting $L = 5 \times 10^{-3} \text{ H}$ and applying these computations will lead to a power around 95W which is close to the target.

A perturbation is introduced at 1 second, reducing the resistance to 2.9Ω . This is done to see how the system will act, and how much time does it takes for it to go back to normal behavior.

In addition, an LC filter was needed to smooth the inverter output voltage and current waveform, and to reduce the distortions and remove the ripples coming from the PWM.

The choice of LC was since the sine wave of every phase has a cut off frequency of $2 \times \pi \times 50 \text{ Hz}$. Therefore, based on the equation

$$f_c = \frac{1}{2 \times \pi \times \sqrt{LC}} \quad \text{Eq.12}$$

The result of the equation should be lower than $2 \times \pi \times 50 \text{ Hz}$. As such, the chosen value of $L = 2 \times 10^{-3} \text{ H}$ and $C = 5 \times 10^{-4} \text{ F}$.

The resulting three phase current is as follows:

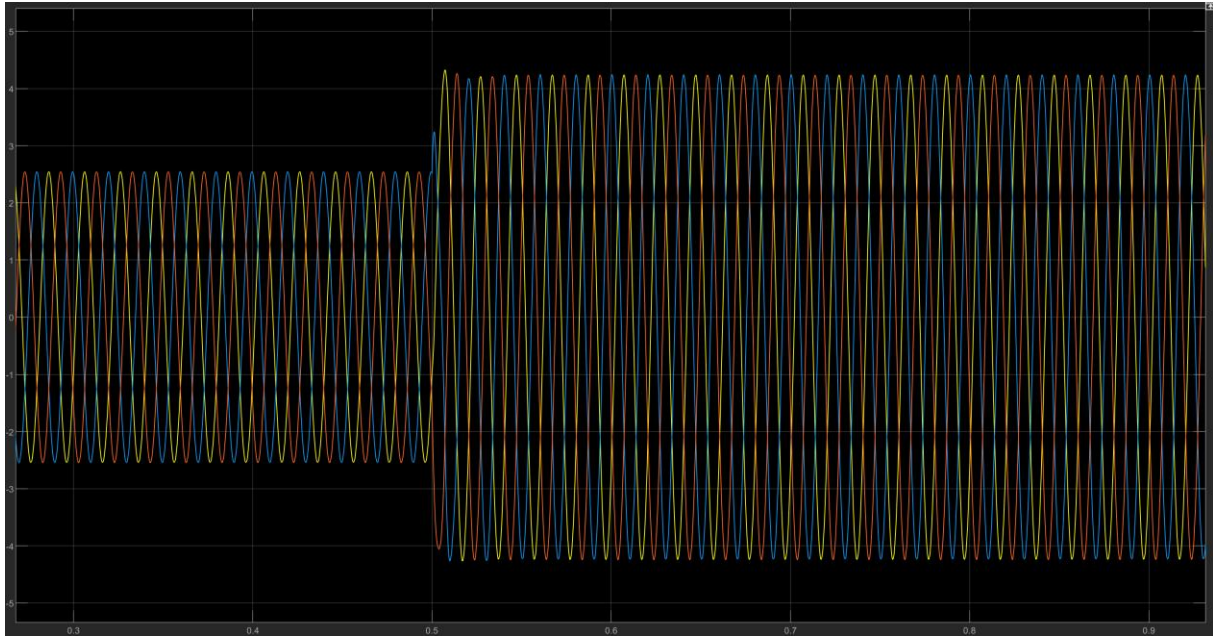

Figure 33: current plot.

Based on figure 33, the current increase from 2.6A to 4.3A after perturbation. Which is almost double the value, this is supposed to happen based on the following equation:

$$I = \frac{V}{R} = \frac{V}{R/2} = 2 \frac{V}{R} = 2I_{old} \quad \text{Eq.13}$$

In addition, after perturbation, it takes only around 0.001 seconds for the behavior to go back to normal.

The resulting three phase voltage is as follows:

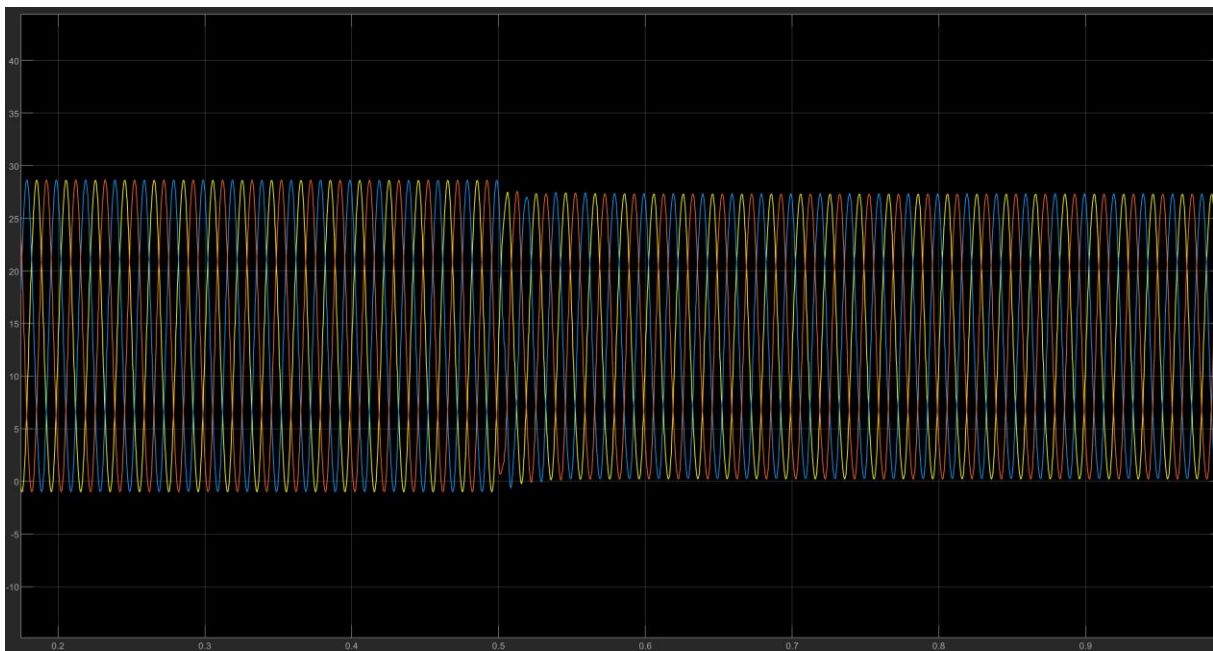

Figure 34: Voltage plot.

Based on figure 34, due to the presence of the filter, the waveform is smooth, with a voltage of 28V. After perturbation, the voltage goes down to 26V. which is reasonable, because the more the current increases, the bigger the voltage drop is inside the inverter, therefore the load voltage will decrease.

In addition, after perturbation, it takes only around 0.05 seconds for the behavior to go back to normal.

6.4. Challenges and considerations

Even though hybridization has improved the efficiency and performance of the energy storage system, it faces a lot of challenges along the way. For instance, the cost can be a major issue, which goes back to how expensive the elements used are, and to the process from the start till the end [108].

In addition, safety issues might arise as well, going back to the material used, for example, as already mentioned, how flammable the lithium-ion batteries are, which eventually will affect the whole hybrid system. Therefore, a lot of testing and validation methods are required for the system to ensure its safety [108].

6.5. Application of a hybrid system

An application for a hybrid system is a Siemens product called "Sitras HES" which is a hybrid energy storage system for rail vehicles, it combines the advantages of a powerful double-layer capacitors and traction batteries which are rechargeable energy storage systems, designed specifically for traction of EVs or other mobile equipment. They must deliver high energy for an extended period of time in addition to the high cycle life. These batteries can be lithium-ion batteries [109].

In this system, all the features, such as usable energy and maximum power, of the supercapacitor are specified depending on the project and the application. In addition, the value of the operating voltage depends on the project, and it can range between 190V and 720V [109].

Also, for the traction battery, all the usable energy, maximum power, and the nominal voltage are specified by the project [109].

Bibliography

- [1] R. Cecchini and G. Pelosi, 'Alessandro Volta and his battery', *IEEE Antennas Propag. Mag.*, vol. 34, no. 2, pp. 30–37, Apr. 1992, doi: 10.1109/74.134307.
- [2] C. Pillot, 'The rechargeable battery market and main trends 2020–2030', [Online]. Available: <http://www.energycluster.it/it/eventi/la-filiera-delle-batterie-sfide-e-opportunita-per-la-lombardia/1-batterie-per-il-settore-automotive-mercato-trend-sfide-e-opportunita-pillot-avicenne.pdf>
- [3] Y. Huh, 'Future direction of power management in mobile devices', in *IEEE Asian Solid-State Circuits Conference 2011*, Jeju, South Korea: IEEE, Nov. 2011, pp. 1–4. doi: 10.1109/ASSCC.2011.6123657.
- [4] X. Yi, L. Tang, R. Cheng, M. Yin, and Y. Zheng, 'Domain ontology to integrate building-integrated photovoltaic, battery energy storage, and building energy flexibility information for explicable operation and maintenance', *Comput. Ind.*, vol. 166, p. 104250, Apr. 2025, doi: 10.1016/j.compind.2025.104250.
- [5] S. wolf and J. Olarte, 'Battery Market Segmentation', in *Emerging Battery Technologies to Boost the Clean Energy Transition*. [Online]. Available: https://link.springer.com/chapter/10.1007/978-3-031-48359-2_6

- [6] Z. Šimić, D. Topić, G. Knežević, and D. Pelin, 'Battery energy storage technologies overview', *Int. J. Electr. Comput. Eng. Syst.*, vol. 12, no. 1, pp. 53–65, Apr. 2021, doi: 10.32985/ijeces.12.1.6.
- [7] A. K. Koech, G. Mwandila, F. Mulolani, and P. Mwaanga, 'Lithium-ion battery fundamentals and exploration of cathode materials: A review', *South Afr. J. Chem. Eng.*, vol. 50, pp. 321–339, Oct. 2024, doi: 10.1016/j.sajce.2024.09.008.
- [8] J. DAMSTRÖM, 'Life cycle cost analysis of lithium ion batteries using different charging strategies: case study Stockholm Arlanda airport'. DEGREE PROJECT ENERGY AND ENVIRONMENT, SECOND CYCLE, STOCKHOLM SWEDEN2018. [Online]. Available: chrome-extension://efaidnbmnnnibpcajpcglclefindmkaj/https://kth.diva-portal.org/smash/get/diva2:1297262/FULLTEXT01.pdf
- [9] A. K. Mishra, Monika, and B. S. Patial, 'A review on recent advances in anode materials in lithium ion batteries', *Mater. Today Electron.*, vol. 7, p. 100089, May 2024, doi: 10.1016/j.mtelec.2024.100089.
- [10] M. Şen, M. Özcan, and Y. R. Eker, 'A review on the lithium-ion battery problems used in electric vehicles', *Sustain.*, vol. 3, p. 100036, Jan. 2024, doi: 10.1016/j.nxsust.2024.100036.
- [11] T. Pattnaik, M. Kumar, and M. S. Ballal, 'Predicting SoH and RUL of Li-ion Batteries in Electric Vehicles: A Comprehensive Review and Chemistry

- Insights', in *2023 IEEE International Conference on Power Electronics, Smart Grid, and Renewable Energy (PESGRE)*, Dec. 2023, pp. 1–6. doi: 10.1109/PESGRE58662.2023.10404475.
- [12] R. Dell and D. A. J. Rand, *Understanding batteries*. in RSC paperbacks. Cambridge: Royal Society of Chemistry, 2001.
- [13] M. Winter and R. J. Brodd, 'What Are Batteries, Fuel Cells, and Supercapacitors?', *Chem. Rev.*, vol. 104, no. 10, pp. 4245–4270, Oct. 2004, doi: 10.1021/cr020730k.
- [14] Castro Michael T., Del Rosario Julie Anne D., and Ocon Joey D., 'Energy Density Optimization in a Primary Alkaline Battery using Multiphysics Modeling', *Chem. Eng. Trans.*, vol. 94, pp. 301–306, Sep. 2022, doi: 10.3303/CET2294050.
- [15] B. Lenhart *et al.*, 'Engineering zinc slurry anodes for high-performance primary alkaline batteries', *J. Power Sources*, vol. 612, p. 234818, Aug. 2024, doi: 10.1016/j.jpowsour.2024.234818.
- [16] J. Song, K. Xu, N. Liu, D. Reed, and X. Li, 'Crossroads in the renaissance of rechargeable aqueous zinc batteries', *Mater. Today*, vol. 45, pp. 191–212, May 2021, doi: 10.1016/j.mattod.2020.12.003.
- [17] X. Yu and S. Licht, 'Advances in Fe(VI) charge storage', *J. Power Sources*, vol. 171, no. 2, pp. 966–980, Sep. 2007, doi: 10.1016/j.jpowsour.2007.06.052.

- [18] K. Kordesch and W. Taucher-Mautner, 'PRIMARY BATTERIES – AQUEOUS SYSTEMS | Leclanché and Zinc–Carbon', in *Encyclopedia of Electrochemical Power Sources*, Elsevier, 2009, pp. 43–54. doi: 10.1016/B978-044452745-5.00097-6.
- [19] Z. Wang, N. Bramnik, S. Roy, G. Di Benedetto, J. L. Zunino, and S. Mitra, 'Flexible zinc–carbon batteries with multiwalled carbon nanotube/conductive polymer cathode matrix', *J. Power Sources*, vol. 237, pp. 210–214, Sep. 2013, doi: 10.1016/j.jpowsour.2013.02.094.
- [20] A. Willert, S. Voigt, T. Zschau, and R. Zichner, 'Printed Primary Battery in a Rolled-Up Form Factor', *Designs*, vol. 8, no. 4, p. 62, Jun. 2024, doi: 10.3390/designs8040062.
- [21] F. Santos, A. Urbina, J. Abad, R. López, C. Toledo, and A. J. Fernández Romero, 'Environmental and economical assessment for a sustainable Zn/air battery', *Chemosphere*, vol. 250, p. 126273, Jul. 2020, doi: 10.1016/j.chemosphere.2020.126273.
- [22] X. Yu *et al.*, 'Flexible fiber-type zinc–carbon battery based on carbon fiber electrodes', *Nano Energy*, vol. 2, no. 6, pp. 1242–1248, Nov. 2013, doi: 10.1016/j.nanoen.2013.06.002.
- [23] P. Sun *et al.*, 'A Lithium-Organic Primary Battery', *Small*, vol. 16, no. 3, p. 1906462, Jan. 2020, doi: 10.1002/smll.201906462.

- [24] A. R. Sevilla, H. Gao, K. Steinberg, and B. M. Gallant, 'Rate Capability of Fluorinated Catholyte-Based Li Primary Batteries Governed by Interfacial and Bulk Li⁺ Transport', *J. Electrochem. Soc.*, vol. 171, no. 11, p. 110505, Nov. 2024, doi: 10.1149/1945-7111/ad8d0f.
- [25] G. J. May, A. Davidson, and B. Monahov, 'Lead batteries for utility energy storage: A review', *J. Energy Storage*, vol. 15, pp. 145–157, Feb. 2018, doi: 10.1016/j.est.2017.11.008.
- [26] A. A. Kebede, T. Kalogiannis, J. Van Mierlo, and M. Berecibar, 'A comprehensive review of stationary energy storage devices for large scale renewable energy sources grid integration', *Renew. Sustain. Energy Rev.*, vol. 159, p. 112213, May 2022, doi: 10.1016/j.rser.2022.112213.
- [27] N. Vangapally *et al.*, 'Lead-acid batteries and lead–carbon hybrid systems: A review', *J. Power Sources*, vol. 579, p. 233312, Sep. 2023, doi: 10.1016/j.jpowsour.2023.233312.
- [28] T. Chen *et al.*, 'Applications of Lithium-Ion Batteries in Grid-Scale Energy Storage Systems', *Trans. Tianjin Univ.*, vol. 26, no. 3, pp. 208–217, Jun. 2020, doi: 10.1007/s12209-020-00236-w.
- [29] Y. Zhang, H. Wu, S. Wang, H. Liao, and C. Dai, 'Electrothermal Coupling Modeling and Electrothermal Dynamic Characteristics of Nickel-Cadmium

- Battery', *J. Phys. Conf. Ser.*, vol. 2706, no. 1, p. 012010, Feb. 2024, doi: 10.1088/1742-6596/2706/1/012010.
- [30] A. Green, 'The characteristics of the nickel-cadmium battery for energy storage', *Power Eng. J.*, vol. 13, no. 3, pp. 117–121, Jun. 1999, doi: 10.1049/pe:19990303.
- [31] W. B. Gu, C. Y. Wang, S. M. Li, M. M. Geng, and B. Y. Liaw, 'Modeling discharge and charge characteristics of nickel–metal hydride batteries', *Electrochimica Acta*, vol. 44, no. 25, pp. 4525–4541, Aug. 1999, doi: 10.1016/S0013-4686(99)00187-5.
- [32] K. Shinyama *et al.*, 'Investigation into the deterioration in storage characteristics of nickel-metal hydride batteries during cycling', *J. Power Sources*, vol. 143, no. 1–2, pp. 265–269, Apr. 2005, doi: 10.1016/j.jpowsour.2004.11.051.
- [33] D. Kumar, S. K. Rajouria, S. B. Kuhar, and D. K. Kancgan, 'Progress and prospects of sodium-sulfur batteries: A review.', *Solid State Ion.*, no. 312, pp. 8–16, 2017.
- [34] T. Oshima, M. Kajita, and A. Okuno, 'Development of Sodium-Sulfur Batteries', *Int. J. Appl. Ceram. Technol.*, vol. 1, no. 3, pp. 269–276, Jul. 2004, doi: 10.1111/j.1744-7402.2004.tb00179.x.
- [35] X. Xu, D. Zhou, K. Lin, F. Kang, B. Li, and G. Wang, 'A room-temperature sodium–sulfur battery with high capacity and stable cycling performance', *Nat. Commun.*, vol. 9(1), no. 3870, 2018.

- [36] M. Ulaganathan, V. Aravindan, Q. Yan, S. Madhavi, M. Skyllas-Kazacos, and T. M. Lim, 'Recent Advancements in All-Vanadium Redox Flow Batteries', *Adv. Mater. Interfaces*, vol. 3, no. 1, p. 1500309, Jan. 2016, doi: 10.1002/admi.201500309.
- [37] A. Parasuraman, T. M. Lim, C. Menictas, and M. Skyllas-Kazacos, 'Review of material research and development for vanadium redox flow battery applications', *Electrochimica Acta*, vol. 101, pp. 27–40, Jul. 2013, doi: 10.1016/j.electacta.2012.09.067.
- [38] J. Fu, Z. P. Cano, M. G. Park, A. Yu, M. Fowler, and Z. Chen, 'Electrically Rechargeable Zinc–Air Batteries: Progress, Challenges, and Perspectives', *Adv. Mater.*, vol. 29, no. 7, p. 1604685, Feb. 2017, doi: 10.1002/adma.201604685.
- [39] W. Fang, J. Zhao, W. Zhang, P. Chen, Z. Bai, and M. Wu, 'Recent progress and future perspectives of flexible Zn-Air batteries', *J. Alloys Compd.*, vol. 869, p. 158918, Jul. 2021, doi: 10.1016/j.jallcom.2021.158918.
- [40] Y. Li and H. Dai, 'Recent advances in zinc–air batteries', *Chem Soc Rev*, vol. 43, no. 15, pp. 5257–5275, 2014, doi: 10.1039/C4CS00015C.
- [41] N. Boaretto *et al.*, 'Lithium solid-state batteries: State-of-the-art and challenges for materials, interfaces and processing', *J. Power Sources*, vol. 502, p. 229919, Aug. 2021, doi: 10.1016/j.jpowsour.2021.229919.

- [42] J. G. Kim *et al.*, 'A review of lithium and non-lithium based solid state batteries', *J. Power Sources*, vol. 282, pp. 299–322, May 2015, doi: 10.1016/j.jpowsour.2015.02.054.
- [43] J. Schnell *et al.*, 'All-solid-state lithium-ion and lithium metal batteries – paving the way to large-scale production', *J. Power Sources*, vol. 382, pp. 160–175, Apr. 2018, doi: 10.1016/j.jpowsour.2018.02.062.
- [44] Q. Li, Y. Shao, X. Shao, H. Liu, and G. Xie, 'Activation process modeling and performance analysis of thermal batteries considering ignition time interval of heat pellets', *Energy*, vol. 219, p. 119631, Mar. 2021, doi: 10.1016/j.energy.2020.119631.
- [45] T.-R. Park, H. Park, K. Kim, C.-N. Im, and J.-H. Cho, 'Heat and weight optimization methodology of thermal batteries by using deep learning method with multi-physics simulation', *Energy Convers. Manag.*, vol. 236, p. 114033, May 2021, doi: 10.1016/j.enconman.2021.114033.
- [46] T. Nemeth, P. Schröer, M. Kuipers, and D. U. Sauer, 'Lithium titanate oxide battery cells for high-power automotive applications – Electro-thermal properties, aging behavior and cost considerations', *J. Energy Storage*, vol. 31, p. 101656, Oct. 2020, doi: 10.1016/j.est.2020.101656.

- [47] J. C. Stallard *et al.*, 'Mechanical properties of cathode materials for lithium-ion batteries', *Joule*, vol. 6, no. 5, pp. 984–1007, May 2022, doi: 10.1016/j.joule.2022.04.001.
- [48] W.-J. Zhang, 'Structure and performance of LiFePO₄ cathode materials: A review', *J. Power Sources*, vol. 196, no. 6, pp. 2962–2970, Mar. 2011, doi: 10.1016/j.jpowsour.2010.11.113.
- [49] R. Konar, S. Maiti, N. Shpigel, and D. Aurbach, 'Reviewing failure mechanisms and modification strategies in stabilizing high-voltage LiCoO₂ cathodes beyond 4.55V', *Energy Storage Mater.*, vol. 63, p. 103001, Nov. 2023, doi: 10.1016/j.ensm.2023.103001.
- [50] C. M. Julien and A. Mauger, 'Fabrication of Li₄Ti₅O₁₂ (LTO) as Anode Material for Li-Ion Batteries', *Micromachines*, vol. 15, no. 3, p. 310, Feb. 2024, doi: 10.3390/mi15030310.
- [51] K. Nishimura, T. Douzono, M. Kasai, H. Andou, Y. Muranaka, and Y. Kozono, 'Spinel-type lithium–manganese oxide cathodes for rechargeable lithium batteries', *J. Power Sources*, vol. 81–82, pp. 420–424, Sep. 1999, doi: 10.1016/S0378-7753(99)00224-4.
- [52] P. Gupta and P. Gudmundson, 'Modeling of local electrode stresses and pressures in lithium-ion battery packs using three-dimensional

- homogenization', *J. Power Sources*, vol. 582, p. 233514, Oct. 2023, doi: 10.1016/j.jpowsour.2023.233514.
- [53] J. Full, J. Wanner, S. Kiemel, R. Miehe, M. Weeber, and A. Sauer, 'Comparing Technical Criteria of Various Lithium-Ion Battery Cell Formats for Deriving Respective Market Potentials', in *2020 IEEE Electric Power and Energy Conference (EPEC)*, Edmonton, AB, Canada: IEEE, Nov. 2020, pp. 1–6. doi: 10.1109/EPEC48502.2020.9320122.
- [54] P. Cicconi and P. Kumar, 'Design approaches for Li-ion battery packs: A review', *J. Energy Storage*, vol. 73, p. 109197, Dec. 2023, doi: 10.1016/j.est.2023.109197.
- [55] N. Kim *et al.*, 'Comparison of Li-ion battery chemistries under grid duty cycles', *J. Power Sources*, vol. 546, p. 231949, Oct. 2022, doi: 10.1016/j.jpowsour.2022.231949.
- [56] G. Wang, Z. Bi, A. Zhang, P. Das, H. Lin, and Z.-S. Wu, 'High-Voltage and Fast-Charging Lithium Cobalt Oxide Cathodes: From Key Challenges and Strategies to Future Perspectives', *Engineering*, vol. 37, pp. 105–127, Jun. 2024, doi: 10.1016/j.eng.2023.08.021.
- [57] C. White, B. Thompson, and L. G. Swan, 'Comparative performance study of electric vehicle batteries repurposed for electricity grid energy arbitrage', *Appl. Energy*, vol. 288, p. 116637, Apr. 2021, doi: 10.1016/j.apenergy.2021.116637.

- [58] Z.-W. Gao, T. Lan, H. Yin, and Y. Liu, 'Development and Commercial Application of Lithium-Ion Batteries in Electric Vehicles: A Review', *Processes*, vol. 13, no. 3, Art. no. 3, Mar. 2025, doi: 10.3390/pr13030756.
- [59] T. Bank, S. Klamor, N. Löffler, and D. U. Sauer, 'Performance benchmark of state-of-the-art high-power lithium-ion cells and implications for their usability in low-voltage applications', *J. Energy Storage*, vol. 36, p. 102383, Apr. 2021, doi: 10.1016/j.est.2021.102383.
- [60] S. Evro, A. Ajumobi, D. Mayon, and O. S. Tomomewo, 'Navigating battery choices: A comparative study of lithium iron phosphate and nickel manganese cobalt battery technologies', *Future Batter.*, vol. 4, p. 100007, Dec. 2024, doi: 10.1016/j.fub.2024.100007.
- [61] A. J. Crawford *et al.*, 'Lifecycle comparison of selected Li-ion battery chemistries under grid and electric vehicle duty cycle combinations', *J. Power Sources*, vol. 380, pp. 185–193, Mar. 2018, doi: 10.1016/j.jpowsour.2018.01.080.
- [62] N. Andrenacci, F. Vitiello, C. Boccaletti, and F. Vellucci, 'Powering the Future Smart Mobility: A European Perspective on Battery Storage', *Batteries*, vol. 11, no. 5, Art. no. 5, May 2025, doi: 10.3390/batteries11050185.
- [63] Y. Wang, X. Zhang, K. Li, G. Zhao, and Z. Chen, 'Perspectives and challenges for future lithium-ion battery control and management', *eTransportation*, vol. 18, p. 100260, Oct. 2023, doi: 10.1016/j.etrans.2023.100260.

- [64] A. Pesaran, S. S. S, and K. G,H, 'Addressing the impact of temperature extremes on large format li-ion batteries for vehicle applications', CO (United States), 2013.
- [65] K. Chen, J. Luo, and Y. Huang, 'Impact of low temperature exposure on lithium-ion batteries: A multi-scale study of performance degradation, predictive signals and underlying mechanisms', *Chem. Eng. J.*, vol. 503, p. 158260, Jan. 2025, doi: 10.1016/j.cej.2024.158260.
- [66] S. Ma *et al.*, 'Temperature effect and thermal impact in lithium-ion batteries: A review', *Prog. Nat. Sci. Mater. Int.*, vol. 28, no. 6, pp. 653–666, Dec. 2018, doi: 10.1016/j.pnsc.2018.11.002.
- [67] G. Nagasubramanian, '[No title found]', *J. Appl. Electrochem.*, vol. 31, no. 1, pp. 99–104, 2001, doi: 10.1023/A:1004113825283.
- [68] T. Gao *et al.*, 'Effect of aging temperature on thermal stability of lithium-ion batteries: Part A – High-temperature aging', *Renew. Energy*, vol. 203, pp. 592–600, Feb. 2023, doi: 10.1016/j.renene.2022.12.092.
- [69] S. S. Zhang, K. Xu, and T. R. Jow, 'The low temperature performance of Li-ion batteries', *J. Power Sources*, vol. 115, no. 1, pp. 137–140, Mar. 2003, doi: 10.1016/S0378-7753(02)00618-3.

- [70] Q. Li *et al.*, 'Wide-Temperature Electrolytes for Lithium-Ion Batteries', *ACS Appl. Mater. Interfaces*, vol. 9, no. 22, pp. 18826–18835, Jun. 2017, doi: 10.1021/acsami.7b04099.
- [71] Y. Yang, R. Wang, Z. Shen, Q. Yu, R. Xiong, and W. Shen, 'Towards a safer lithium-ion batteries: A critical review on cause, characteristics, warning and disposal strategy for thermal runaway', *Adv. Appl. Energy*, vol. 11, p. 100146, Sep. 2023, doi: 10.1016/j.adapen.2023.100146.
- [72] A. Dewan and S. K. M, 'Optimizing Lithium-Ion Battery Performance in Electric Vehicles: A Comprehensive Analysis of Temperature, Humidity, and Moisture Effects', in *2024 IEEE 9th International Conference for Convergence in Technology (I2CT)*, Pune, India: IEEE, Apr. 2024, pp. 1–5. doi: 10.1109/I2CT61223.2024.10544144.
- [73] D. Meng, X. Wang, M. Chen, and J. Wang, 'Effects of environmental temperature on the thermal runaway of lithium-ion batteries during charging process', *J. Loss Prev. Process Ind.*, vol. 83, p. 105084, Jul. 2023, doi: 10.1016/j.jlp.2023.105084.
- [74] Y. Chen *et al.*, 'A review of lithium-ion battery safety concerns: The issues, strategies, and testing standards', *J. Energy Chem.*, vol. 59, pp. 83–99, Aug. 2021, doi: 10.1016/j.jechem.2020.10.017.

- [75] J. Jaguemont and F. Bardé, 'A critical review of lithium-ion battery safety testing and standards', *Appl. Therm. Eng.*, vol. 231, p. 121014, Aug. 2023, doi: 10.1016/j.applthermaleng.2023.121014.
- [76] S. C. Levy, 'Safety and reliability considerations for lithium batteries', *J. Power Sources*, vol. 68, no. 1, pp. 75–77, Sep. 1997, doi: 10.1016/S0378-7753(96)02622-5.
- [77] J. Zhao, X. Feng, M.-K. Tran, M. Fowler, M. Ouyang, and A. F. Burke, 'Battery safety: Fault diagnosis from laboratory to real world', *J. Power Sources*, vol. 598, p. 234111, Apr. 2024, doi: 10.1016/j.jpowsour.2024.234111.
- [78] P. M. Roy, H. H. Sawant, P. P. Shelar, P. U. Sarode, and S. H. Gawande, 'Battery health management—a perspective of design, optimization, manufacturing, fault detection, and recycling', *Energy Storage Sav.*, vol. 3, no. 3, pp. 190–208, Sep. 2024, doi: 10.1016/j.enss.2024.04.001.
- [79] X. Lei, F. Xie, J. Wang, and C. Zhang, 'A review of lithium-ion battery state of health and remaining useful life estimation methods based on bibliometric analysis', *J. Traffic Transp. Eng. Engl. Ed.*, vol. 11, no. 6, pp. 1420–1446, Dec. 2024, doi: 10.1016/j.jtte.2024.09.004.
- [80] M. Gutsch and J. Leker, 'Costs, carbon footprint, and environmental impacts of lithium-ion batteries – From cathode active material synthesis to cell manufacturing and recycling', *Appl. Energy*, vol. 353, p. 122132, Jan. 2024, doi: 10.1016/j.apenergy.2023.122132.

- [81] '7 things you should know about the cost of maintaining an electric car' - MarketWatch'. Accessed: May 19, 2025. [Online]. Available: <https://www.marketwatch.com/story/7-things-you-should-know-about-the-cost-of-maintaining-an-electric-car-7c5ce560>
- [82] '50MW Battery Storage Cost: An In-depth Analysis-Ritar International Group Limited'. Accessed: May 19, 2025. [Online]. Available: https://www.ritarpower.com/industry_information/50MW-Battery-Storage-Cost-An-In-depth-Analysis_286.html
- [83] S. Orangi, N. Manjong, D. P. Clos, L. Usai, O. S. Burheim, and A. H. Strømman, 'Historical and prospective lithium-ion battery cost trajectories from a bottom-up production modeling perspective', *J. Energy Storage*, vol. 76, p. 109800, Jan. 2024, doi: 10.1016/j.est.2023.109800.
- [84] 'Tesla Powerwall 3 Review', Clean Energy Reviews. Accessed: May 19, 2025. [Online]. Available: <https://www.cleanenergyreviews.info/blog/tesla-powerwall-3-review>
- [85] 'Tesla LFP Model 3 - Battery Design'. [Online]. Available: <https://www.batterydesign.net/tesla-lfp-model-3/>
- [86] 'Tesla Model 3 Standard Range Plus LFP (2020-2021) price and specifications - EV Database'. Accessed: May 19, 2025. [Online]. Available: <https://ev-database.org/car/1320/Tesla-Model-3-Standard-Range-Plus-LFP>

- [87] 'Products', E-gap Engineering. Accessed: May 19, 2025. [Online]. Available: <https://www.e-gapengineering.com/en/products/>
- [88] 'Utility-scale battery energy storage system (BESS)'. Accessed: May 19, 2025. [Online]. Available: <https://search.abb.com/library/Download.aspx?DocumentID=9AKK107992A4519&DocumentPartId>
- [89] 'Search Result'. Accessed: May 19, 2025. [Online]. Available: https://digitalpower.huawei.com/en/news_search.html?searchKeywords=SmartLi%203.0
- [90] 'NCR18650B Panasonic Battery LI-ION', PowerBattery. Accessed: May 19, 2025. [Online]. Available: <https://powerbattery.it/prodotto/panasonic-ncr18650b-batteria-li-ion/>
- [91] M. A. Hannan, Md. M. Hoque, A. Hussain, Y. Yusof, and P. J. Ker, 'State-of-the-Art and Energy Management System of Lithium-Ion Batteries in Electric Vehicle Applications: Issues and Recommendations', *IEEE Access*, vol. 6, pp. 19362–19378, 2018, doi: 10.1109/ACCESS.2018.2817655.
- [92] F. Arshad *et al.*, 'Life Cycle Assessment of Lithium-ion Batteries: A Critical Review', *Resour. Conserv. Recycl.*, vol. 180, p. 106164, May 2022, doi: 10.1016/j.resconrec.2022.106164.

- [93] X. Guo, Y. Cai, and D. Ren, 'Research on carbon footprint of lithium battery life cycle considering carbon transfer', *J. Energy Storage*, vol. 122, p. 116638, Jun. 2025, doi: 10.1016/j.est.2025.116638.
- [94] A. Parlikar, B. Tepe, M. Möller, H. Hesse, and A. Jossen, 'Quantifying the carbon footprint of energy storage applications with an energy system simulation framework — Energy System Network', *Energy Convers. Manag.*, vol. 304, p. 118208, Mar. 2024, doi: 10.1016/j.enconman.2024.118208.
- [95] W. Wu, N. Cong, X. Zhang, Q. Yue, and M. Zhang, 'Life cycle assessment and carbon reduction potential prediction of electric vehicles batteries', *Sci. Total Environ.*, vol. 903, p. 166620, Dec. 2023, doi: 10.1016/j.scitotenv.2023.166620.
- [96] J. B. Dunn, C. James, L. Gaines, K. Gallagher, Q. Dai, and J. C. Kelly, 'Material and Energy Flows in the Production of Cathode and Anode Materials for Lithium Ion Batteries', Argonne National Lab. (ANL), Argonne, IL (United States), ANL/ESD-14/10 Rev, Sep. 2015. doi: 10.2172/1224963.
- [97] J. B. Dunn, L. Gaines, J. Sullivan, and M. Q. Wang, 'Impact of Recycling on Cradle-to-Gate Energy Consumption and Greenhouse Gas Emissions of Automotive Lithium-Ion Batteries', *Environ. Sci. Technol.*, vol. 46, no. 22, pp. 12704–12710, Nov. 2012, doi: 10.1021/es302420z.

- [98] J. Sadhukhan and M. Christensen, 'An In-Depth Life Cycle Assessment (LCA) of Lithium-Ion Battery for Climate Impact Mitigation Strategies', *Energies*, vol. 14, no. 17, Art. no. 17, Jan. 2021, doi: 10.3390/en14175555.
- [99] A. Alkhalidi, M. K. Khawaja, and S. M. Ismail, 'Solid-state batteries, their future in the energy storage and electric vehicles market', *Sci. Talks*, vol. 11, p. 100382, Sep. 2024, doi: 10.1016/j.sctalk.2024.100382.
- [100] T. H. Dolla, S. O. Ajayi, L. L. Sikeyi, M. K. Mathe, and N. Palaniyandy, 'Advances in solid-state batteries fabrication strategies for their manufacture', *J. Energy Storage*, vol. 106, p. 114737, Jan. 2025, doi: 10.1016/j.est.2024.114737.
- [101] H. Xu and M. Shen, 'The control of lithium-ion batteries and supercapacitors in hybrid energy storage systems for electric vehicles: A review', *Int. J. Energy Res.*, vol. 45, no. 15, pp. 20524–20544, 2021, doi: 10.1002/er.7150.
- [102] D. Gao, Z. Luo, C. Liu, and S. Fan, 'A survey of hybrid energy devices based on supercapacitors', *Green Energy Environ.*, vol. 8, no. 4, pp. 972–988, Aug. 2023, doi: 10.1016/j.gee.2022.02.002.
- [103] C. V. M. Gopi and R. Ramesh, 'Review of battery-supercapacitor hybrid energy storage systems for electric vehicles', *Results Eng.*, vol. 24, p. 103598, Dec. 2024, doi: 10.1016/j.rineng.2024.103598.

- [104] J. Dai *et al.*, 'A solid state energy storage device with supercapacitor–battery hybrid design', *J. Mater. Chem. A*, vol. 5, no. 29, pp. 15266–15272, Jul. 2017, doi: 10.1039/C7TA02638B.
- [105] S. Mandal *et al.*, 'Recent advancement and design in supercapacitor hybrid electrode materials: Bridging the gap between energy and power density', *Chem. Eng. J. Adv.*, vol. 21, p. 100690, Mar. 2025, doi: 10.1016/j.ceja.2024.100690.
- [106] F. Zhang *et al.*, 'A high-performance supercapacitor-battery hybrid energy storage device based on graphene-enhanced electrode materials with ultrahigh energy density', *Energy Environ. Sci.*, vol. 6, no. 5, pp. 1623–1632, Apr. 2013, doi: 10.1039/C3EE40509E.
- [107] T. Zimmermann, P. Keil, M. Hofmann, M. F. Horsche, S. Pichlmaier, and A. Jossen, 'Review of system topologies for hybrid electrical energy storage systems', *J. Energy Storage*, vol. 8, pp. 78–90, Nov. 2016, doi: 10.1016/j.est.2016.09.006.
- [108] A. G. Abo-Khalil, A. Sobhy, M. A. Abdelkareem, and A. G. Olabi, 'Advancements and challenges in hybrid energy storage systems: Components, control strategies, and future directions', *Int. J. Thermofluids*, vol. 20, p. 100477, Nov. 2023, doi: 10.1016/j.ijft.2023.100477.

[109] 'Rail Electrification', Siemens Mobility Global. Accessed: Jun. 23, 2025. [Online].

Available: <https://www.mobility.siemens.com/global/en/portfolio/rail-infrastructure/electrification.html>

Appendix A: Definitions

Appendix A contains definitions needed for some keywords used in the literature review.

From [6]

Nominal cell voltage is the voltage measured between positive and negative terminals of a battery cell.

Specific energy is the available energy of battery per unit mass.

Energy density is the available energy of battery per unit volume.

Lifespan or lifetime represent the number of years during which the battery keeps the minimum working performance, before the need to be replaced.

Efficiency is the ratio between energy that can be discharged from the battery and energy used to charge the battery.

Self-discharging rate is the amount that is discharged when the battery is not in use.

Working temperature is the temperature range at which the battery can operate without any reduction in performance.

Life cycle is the number of complete charge and discharge cycles it can undergo before its capacity falls below a specified percentage (usually below 80%).

Charge-transfer resistance is the electrical resistance encountered by lithium ions as they move across the electrode-electrolyte interface during charging and discharging. The lower it is, the better the battery performance is, by allowing faster ion movements, leading to higher efficiency and lower heat generation.

Electrochemical reactions involve the movement of lithium ions between the anode and the cathode during charging and discharging. These reactions are responsible for energy storage and release in the battery.

Charge/Discharge rate (C rate) is the speed at which the battery is charged or discharged. The higher the C rate is, the faster the charging or discharging process is.

A 1C rate means the battery is fully charged or discharged in 1 hour.

A 0.5C rate means it takes 2 hours.

A 2C rate means it takes 30 minutes

Appendix B: MATLAB code

Appendix B includes the MATLAB code used in Chapter 4 for the LCA assessment for different types of lithium-ion batteries.

```
% Lithium-ion batteries LCA assessment
clc;
clear;

% Step 1: Database for LCI- read the data from csv file
LCI_Data = readtable("data.xlsx");

% Step 2: Database for Emission factor-read the data from csv file
Emission_factor = readtable("EF.xlsx");

% Step 3: table for results
battery_types = unique(LCI_Data.Battery_Type);
results = table();

for i = 1:length(battery_types)
    battery_type = battery_types(i);

    LCI = LCI_Data(strcmp(LCI_Data.Battery_Type, battery_type), :);
    EF = Emission_factor(strcmp(Emission_factor.Battery_Type, battery_type), :);

    LCI = table2struct(LCI);
    EF = table2struct(EF);

    %step 4: emission calculation for the battery battery type (whole process)
    % 1- mining and production
    Mining_emissions =(LCI.Li .* EF.Li) + (LCI.Co .* EF.Co) + (LCI.Ni .*
EF.Ni)+...
    (LCI.Graphite .* EF.Graphite) + (LCI.Al .* EF.Al) + (LCI.Cu .*
EF.Cu)+...
    (LCI.Energy_Mining .* EF.Electricity);

    %2- manufacturing
    Manufacturing_emissions = LCI.Energy_Manufacturing .* EF.Electricity;

    %3- transport
    weight_kg= LCI.Li + LCI.Co+LCI.Ni+LCI.Graphite+LCI.Al+LCI.Cu;
    weight_tons= weight_kg/1000;
    transport_emissions= weight_tons* LCI.Transport_Distance .* EF.Transport;

    %4- recycling
    total_material_kg=LCI.Li+LCI.Co+LCI.Ni+LCI.Graphite+LCI.Al+LCI.Cu;
    recycling_rate = LCI.Recycling_Rate / 100;
    recycling_emissions=-recycling_rate .* total_material_kg .*
EF.Recycling_Saving;

    %5- total emissions per kWh
```

```

total_emissions=
Mining_emissions+Manufacturing_emissions+transport_emissions+recycling_emission
s;

% result in a table
results=[results;table(battery_type, Mining_emissions,
Manufacturing_emissions, transport_emissions,...
    recycling_emissions, total_emissions, 'VariableNames', {'Battery_Type',
...
'Mining_kgCO2eq', 'Manufacturing_kgCO2eq', 'Transport_kgCO2eq', ...
'Recycling_kgCO2eq', 'Total_kgCO2eq'} )];
end

%step 5: display the results
disp('---LCA RESULTS FOR LITHIUM-ION BATTERIES ---');
disp(results);

% plots:
figure;
bar(categorical(results.Battery_Type),data);

xlabel('Battery Type');
ylabel('Emission (Kg CO2-eq)');
title('lithium-ion batteries per battery unit LCA assessment');

%step 6: sensitivity analysis: electricity emission factor
EFs = 0.05:0.01:0.10;
results_sensitivity = zeros(length(EFs), length(battery_types));

for j= 1:length(battery_types)
    battery_type= battery_types(j);
    LCI = LCI_Data(strcmp(LCI_Data.Battery_Type, battery_type), :);
    EF = Emission_factor(strcmp(Emission_factor.Battery_Type, battery_type),:);
    LCI = table2struct(LCI);
    EF = table2struct(EF);

    for i = 1:length(EFs)
        EF.Electricity = EFs(i);

        Mining_emissions =(LCI.Li .* EF.Li) + (LCI.Co .* EF.Co) + (LCI.Ni .*
EF.Ni)+...
        (LCI.Graphite .* EF.Graphite) + (LCI.Al .* EF.Al) + (LCI.Cu .*
EF.Cu)+...
        (LCI.Energy_Mining .* EF.Electricity);

        Manufacturing_emissions = LCI.Energy_Manufacturing .* EF.Electricity;

        weight_kg= LCI.Li + LCI.Co+LCI.Ni+LCI.Graphite+LCI.Al+LCI.Cu;
        weight_tons= weight_kg/1000;
        transport_emissions= weight_tons* LCI.Transport_Distance .*
EF.Transport;

        total_material_kg=LCI.Li+LCI.Co+LCI.Ni+LCI.Graphite+LCI.Al+LCI.Cu;
        recycling_rate = LCI.Recycling_Rate / 100;

```

```
    recycling_emissions=-recycling_rate .* total_material_kg .*  
EF.Recycling_Saving;  
  
    %total emissions  
    total_emissions=  
Mining_emissions+Manufacturing_emissions+transport_emissions+recycling_emission  
s;  
  
% result for sensitivity analysis  
    results_sensitivity(i,j) = total_emissions;  
    end  
end  
  
% plot  
figure;  
hold on;  
for j=1:length(battery_types)  
    plot(EFs, results_sensitivity(:,j), '-o', 'DisplayName', battery_types{j});  
xlabel('electricity emission factor (kg CO2-eq/Mj)');  
ylabel('sensitivity of battery LCA to electricity Source');  
legend("show");  
grid on;  
  
end
```

List of Tables

Table 1: comparison of secondary batteries.	17
Table 2: Parameters for the different types of LIBs.	26
Table 3: Cost of every Life Cycle stages.	36
Table 4: Cost of transportation.	37
Table 5: Cost of Maintenance.	37
Table 6: Comparison table between the obtained values and the values from the sources.	49
Table 7: Electrical parameters of SSBs.	51
Table 8: Comparison table between LIBs and SSBs.	53
Table 9: Cost comparison and prediction between LIBs and SSBs.	54
Table 10: Characteristics of hybrid system consisting of LIBs and supercapacitors.	56
Table 11: Characteristics of hybrid systems consisting of SSBs and supercapacitors.	57

List of Figures

Figure 1: Li-ion battery diagram[7].	9
Figure 2: Binders in Li-ion battery [8].	10
Figure 3: Charge/Discharge operations of Li-ion battery [9].	11
Figure 4: Nominal voltage of different types of batteries.	18
Figure 5: Specific energy of different types of batteries.	18
Figure 6: Energy density of different types of batteries.	19
Figure 7: Lifespan of different types of batteries.	19
Figure 8: Efficiency of different types of batteries.	20
Figure 9: Self-discharge rate of different types of batteries.	20
Figure 10: Operating temperature of different types of batteries.	21
Figure 11: Charge voltage of different types of LIBs.	28
Figure 12: Cell capacity of different types of LIBs.	28
Figure 13: Energy density of different types of LIBs.	29
Figure 14: Specific energy of different types of LIBs.	29
Figure 15: Specific power of different types of LIBs.	30
Figure 16: Cycle life of different types of LIBs.	30
Figure 17: Efficiency of different types of LIBs.	30
Figure 18: Comparison in peak energy release for different types of LIBs [10].	33
Figure 19: different LCA impact categories [92].	44
Figure 20: LCA assessment steps block diagram.	45
Figure 21: sample LCI data per kWh usable capacity.	45
Figure 22: sample of emission factors of material used for LIB production.	46
Figure 23: MATLAB code including the steps of life cycle of a LIB.	46
Figure 24: Results of the MATLAB code.	47
Figure 25: LCA Result in a chart.	47
Figure 26: Sensitivity analysis results.	48
Figure 27: comparison chart between LIBs and SSBs.	54

Figure 28: Specific power vs Specific energy for different batteries [103].	56
Figure 29: Comparison Chart for different parameters.	58
Figure 30: block diagram of hybrid energy storage topology [108].	59
Figure 31: Passive hybrid system schematic.	61
Figure 32: Pulse width modulation schematic.	61
Figure 33: current plot.	63
Figure 34: Voltage plot.	63

Abbreviations

Abbreviation	Meaning
PV	Photovoltaic
UPS	Uninterrupted power system
LIBS	Lithium-ion batteries
EVs	Electrical Vehicles
HEVs	Hybrid Electrical Vehicles
SEI	Solid Electrolyte Interphase
IEC	International Electrotechnical Commission
IEEE	Institute of Electrical and Electronics Engineers
ISO	International Organization for Standardization
BMS	Battery management system
LIB	Lithium-ion Battery
SC	Supercapacitor
SSB	Solid-state battery
LCO	Lithium Cobalt Oxide
LFP	Lithium Iron Phosphate
NMC	Lithium Nickel Manganese Cobalt Oxide
NCA	Lithium Nickel Cobalt Aluminum Oxide

LMO	Lithium Manganese Oxide
LTO	Lithium titanate

List of symbols

Variable	Description	SI unit
GWh	Used for energy consumption	Joule
V	Voltage	Volt
A	Current	Amps
Wh/kg	Unit for energy of battery per unit mass	J/Kg
KWh/L	Unit for energy of battery per unit Volume	J/m³
Ah	Unit to measure battery capacity	Coulomb (C)
°C	Temperature unit	Kelvin (K)
KWh	Unit of energy for one kilowatt of power used for one hour	Joule
\$/kWh	Dollar per kilowatt of power used for one hour	\$/Joule
KgCO₂-eq	Kilogram of Carbon Dioxide equivalent	KgCO₂-eq

Acknowledgments

I would like to show my sincere gratitude to my advisor, professor Marco Faifer, for his continuous support, encouragement and detailed feedback during the pursuit of the research. His expertise and dedication were the main contribution to this study.

I would also like to thank the Department of Electrical Engineering of Politecnico di Milano for this great learning experience, and for supplying the necessary tools to carry out this research.

Special thanks to my friends, for their support and understanding throughout this process.

Above all, I am deeply grateful to my family, for their unconditional love, patience, and encouragement. Which gave me strength and persistence throughout this academic journey.